

**CALIFORNIA REGIONAL WATER QUALITY CONTROL BOARD
LAHONTAN REGION**

2501 Lake Tahoe Boulevard, South Lake Tahoe, CA 96150
(530) 542-5400 • Fax (530) 544-2271
<http://www.waterboards.ca.gov/lahontan>

**ORDER NO. R6V-2017-TENTATIVE
NPDES NO. CA0102814
WDID NO. 6B360812001**

**REISSUED WASTE DISCHARGE REQUIREMENTS AND
NATIONAL POLLUTANT DISCHARGE ELIMINATION SYSTEM PERMIT
FOR THE CALIFORNIA DEPARTMENT OF FISH AND WILDLIFE
MOJAVE RIVER FISH HATCHERY
SAN BERNARDINO COUNTY**

The following Discharger is subject to waste discharge requirements (WDRs) set forth in this Order:

Table 1. Discharger Information

Discharger	California Department of Fish and Wildlife
Name of Facility	Mojave River Fish Hatchery
Facility Address	12550 Jacaranda Avenue
	Victorville, California 92395
	San Bernardino County

Table 2. Discharge Location

Discharge Point	Effluent Description	Discharge Point Latitude (North)	Discharge Point Longitude (West)	Receiving Water
001	Fish Hatchery Wastewater	34° 28' 50" N	117° 15' 36" W	Mojave River and adjacent wetlands
002	Fish Hatchery Wastewater	34° 28' 47" N	117° 15' 45" W	Upper Mojave River Valley Groundwater Basin, Spring Valley Lake, and other minor surface waters, including wetlands

Table 3. Administrative Information

This Order was adopted on:	May 10, 2017
This Order shall become effective on:	July 1, 2017
This Order shall expire on:	June 30, 2022
The Discharger shall file a Report of Waste Discharge as an application for reissuance of WDRs in accordance with title 23, California Code of Regulations, and an application for reissuance of a National Pollutant Discharge Elimination System (NPDES) permit no later than:	180 days prior to the Order expiration date (December 29, 2021)
The U.S. Environmental Protection Agency (USEPA) and the California Regional Water Quality Control Board, Lahontan Region have classified this discharge as follows:	Minor

I, Patty Z. Kouyoumdjian, Executive Officer, do hereby certify that this Order with all attachments is a full, true, and correct copy of the Order adopted by the California Regional Water Quality Control Board, Lahontan Region, on the date indicated above.

Patty Z. Kouyoumdjian, Executive Officer

Contents

I. Facility Information 3

II. Findings 3

III. Discharge Prohibitions 4

IV. Effluent Limitations and Discharge Specifications 6

 A. Effluent Limitations – Discharge Point 001 6

 1. Final Effluent Limitations – Discharge Points 001 and 002 6

 2. Interim Effluent Limitations – Not Applicable 6

 B. Land Discharge Specifications – Not Applicable 6

 C. Recycling Specifications – Not Applicable 6

V. Receiving Water Limitations 6

 A. Surface Water Limitations 6

 B. Groundwater Limitations 10

VI. Provisions 10

 A. Standard Provisions 10

 B. Monitoring and Reporting Program (MRP) Requirements 12

 C. Special Provisions 12

 1. Reopener Provisions 12

 2. Special Studies, Technical Reports and Additional Monitoring Requirements 13

 3. Best Management Practices and Pollution Prevention 14

 4. Construction, Operation and Maintenance Specifications 16

 5. Special Provisions for Municipal Facilities (POTWs Only) – Not Applicable 17

 6. Other Special Provisions – Not Applicable 17

 7. Compliance Schedules – Not Applicable 17

VII. Compliance Determination 17

Tables

Table 1. Discharger Information 1

Table 2. Discharge Location 1

Table 3. Administrative Information 1

Table 4. Final Effluent Limitations 6

Table 5. Receiving Water Limitations for Radionuclides 8

Table 6. Surface Water Limitations 9

Attachments

Attachment A – Definitions A-1

Attachment B – Map B-1

Attachment C – Flow Schematic C-1

Attachment D – Standard Provisions D-1

Attachment E – Monitoring and Reporting Program E-1

Attachment F – Fact Sheet F-1

Attachment G – Aquaculture Drugs and Chemicals Approved for Use G-1

Attachment H – Drug and Chemical Usage Report Table H-1

Attachment I – Storm Water Pollution Prevention Plan Requirements H-1

Attachment J – Priority Pollutant Metal Monitoring Requirements I-1

Attachment K – Feed Conversion Ratios Log J-1

I. FACILITY INFORMATION

Information describing the Mojave River Fish Hatchery (Facility) is summarized in Table 1 and in sections I and II of the Fact Sheet (Attachment F). Section I of the Fact Sheet also includes information regarding the Facility's permit application.

II. FINDINGS

The California Regional Water Quality Control Board, Lahontan Region (Lahontan Water Board), finds:

- A. Legal Authorities.** This Order serves as Waste Discharge Requirements (WDRs) pursuant to article 4, chapter 4, division 7 of the California Water Code (commencing with section 13260). This Order is also issued pursuant to section 402 of the federal Clean Water Act (CWA) and implementing regulations adopted by the USEPA and chapter 5.5, division 7 of the Water Code (commencing with section 13370). It shall serve as a National Pollutant Discharge Elimination System (NPDES) permit authorizing the Discharger to discharge into waters of the United States at the discharge location described in Table 2 subject to the WDRs in this Order.
- B. Background and Rationale for Requirements.** The Lahontan Water Board developed the requirements in this Order based on information submitted as part of the application, through monitoring and reporting programs, and other available information. The Fact Sheet (Attachment F), which contains background information and rationale for the requirements in this Order, is hereby incorporated into and constitutes Findings for this Order. Attachments A through E and G through K are also incorporated into this Order.
- C. Provisions and Requirements Implementing State Law.** The provisions/requirements in subsections IV.B, IV.C, and V.B are included to implement state law only. These provisions/requirements are not required or authorized under the federal CWA; consequently, violations of these provisions/requirements are not subject to the enforcement remedies that are available for NPDES violations.
- D. California Environmental Quality Act (CEQA)** This action to adopt an NPDES permit is exempt from the provisions of chapter 3 of CEQA (Public Resources Code sections 21100, et seq.), pursuant to section 13389 of the Water Code.
- E. Notification of Interested Parties.** The Lahontan Water Board has notified the Discharger and interested agencies and persons of its intent to prescribe WDRs for the discharge and has provided them with an opportunity to submit their written comments and recommendations. Details of the notification are provided in the Fact Sheet.
- F. Consideration of Public Comment.** The Lahontan Water Board, in a public meeting, heard and considered all comments pertaining to the discharge. Details of the public meeting are provided in the Fact Sheet.

THEREFORE, IT IS HEREBY ORDERED that Order No. R6V-2011-0081 is rescinded upon the effective date of this Order except for enforcement purposes, and, in order to meet the provisions contained in division 7 of the Water Code (commencing with section 13000) and regulations adopted thereunder, and the provisions of the CWA and regulations and guidelines adopted thereunder, the Discharger shall comply with the requirements in this Order. This action in no way prevents the Lahontan Water Board from taking enforcement action for past violations of the previous Order.

III. DISCHARGE PROHIBITIONS

- A. In accordance with the Region-wide and Unit/Area-Specific Prohibitions in section 4.1 of the Basin Plan:
1. The discharge of waste¹ that causes violation of any narrative or numeric water quality objective contained in the Basin Plan is prohibited.
 2. Where any numeric or narrative water quality objective contained in the Basin Plan is already being violated, the discharge of waste that causes further degradation or pollution is prohibited.
 3. The discharge of waste that could affect the quality of waters of the state that is not authorized by the State Water Resources Control Board (State Water Board) or Lahontan Water Board through waste discharge requirements, waiver of waste discharge requirements, NPDES permit, cease and desist order, certification of water quality compliance pursuant to Clean Water Act section 401, or other appropriate regulatory mechanism is prohibited.
 4. The discharge of untreated sewage, garbage, or other solid wastes into surface waters of the Region is prohibited.
 5. The discharge of pesticides to surface or ground waters is prohibited. Exemptions may be granted by the Water Board under a separate permit provided that specific exemption criteria specified in section 4.1 of the Basin Plan are satisfied.
 6. The discharge of hatchery wastewater except to the authorized discharge points (Discharge Points 001 and 002) is prohibited.
 7. There shall be no discharge, bypass, or diversion of hatchery wastewater from the transport or treatment facilities to surface waters except as in compliance with Standard Provisions for bypass (Attachment D).
 8. The discharge shall not cause pollution as defined in Section 13050 of the Water Code, or a threatened pollution.
 9. Neither the treatment nor the discharge of hatchery wastewater shall cause a nuisance as defined in Section 13050 of the Water Code.
 10. The discharge shall not cause a violation of any applicable water quality standards for receiving water adopted by the Lahontan Water Board or the State Water Board.
 - a. The discharge of any therapeutic or pharmaceutical aquaculture drug or chemical resulting in toxicity in receiving waters is prohibited.
 - b. The use of any aquaculture drug or chemical not authorized for discharge in section VI.C.2.a of this Order that may be potentially discharged to waters of the United States or of the State is prohibited. Modifications to the authorized discharge of aquaculture drugs and chemicals at the Facility may be allowed by the Lahontan Water Board as specified in section VI.C.2.a of this Order.
 11. The discharge of hazardous or toxic substances including cleaning chemicals, solvents, oil, grease or other petroleum products, is prohibited.

¹ "Waste" is defined to include any waste or deleterious material including, but not limited to, waste earthen materials (such as soil, silt, sand, clay, rock, or other organic or mineral material) and any other waste as defined in Water Code section 13050 subdivision (d).

12. Practices that may allow accumulated sludge, grit, and solid residues to be discharged to surface waters are prohibited.

B. Storm Water Runoff and Storm Water Collection Systems Prohibitions and Requirements

1. This permit does not supersede any obligation to obtain and maintain coverage under the General Permit for Discharges of Storm Water Associated with Construction Activity (Construction General Permit) or any other permit when such permits are applicable. However, this permit does include substantive requirements applicable for the General Permit for Storm Water Discharges Associated with Industrial Activities (Industrial General Permit).
2. Unless otherwise authorized by a separate waste discharge permit or specifically authorized by this permit, discharges of material other than storm water to a separate storm sewer system, or waters of the State are prohibited. Prohibited non-storm water discharges must either be eliminated or permitted by a separate NPDES permit.
3. **Non-Storm Water Discharges**
 - a. The following non-storm water discharges are authorized by this Order provided that they satisfy the conditions specified in Paragraph b. below: fire hydrant flushing; potable water sources, including potable water related to the operation, maintenance, or testing of potable water systems; drinking fountain water; atmospheric condensates including refrigeration, air conditioning, and compressor condensate; irrigation drainage; landscape watering; springs; groundwater; foundation or footing drainage.
 - b. The non-storm water discharges as identified in Paragraph a., above, are authorized by this Order if all the following conditions are met:
 - i. The non-storm water discharges are in compliance with the Basin Plan requirements.
 - ii. Best Management Practices (BMPs) are specifically included in the Storm Water Pollution Prevention Plan (SWPPP) to (1) prevent or reduce the contact of non-storm water discharges with materials or equipment which may contribute contaminants to the discharge and (2) minimize, to the extent practicable, the flow or volume of non-storm water discharges.
 - iii. The monitoring program includes quarterly visual observations of each non-storm water discharge and its sources to ensure that BMPs are being implemented and are effective.
 - iv. The non-storm water discharges are reported and described in the subsequent quarterly report and are summarized in the annual report.
4. **Visual Observations**
 - a. The Discharger shall perform visual storm water monitoring, as described in Attachment E, within two business days (48 hours) after each qualifying rain event. These observations are to (1) identify whether BMPs have been adequately designed, implemented, and effective, and (2) identify additional BMPs necessary and to revise the SWPPP accordingly.
 - b. Quarterly, the Discharger shall perform visual non-storm water inspections of the facility, as described in Attachment E, to ensure that BMPs are being implemented and are effective.

5. Unless specifically granted, authorization pursuant to this permit does not constitute an exemption to applicable discharge prohibitions in the Basin Plan.
6. Unless authorized by a separate NPDES permit or WDRs, storage and use of materials not designated for outdoor use must be protected from exposure to storm water.
7. Liquids and solutes that may spill, leak, or leach from materials and or equipment used in the Facility must be protected from exposure to storm water.

IV. EFFLUENT LIMITATIONS AND DISCHARGE SPECIFICATIONS

A. Effluent Limitations – Discharge Point 001

1. Final Effluent Limitations – Discharge Points 001 and 002

The Discharger shall maintain compliance with the following effluent limitations at Discharge Points 001 and 002, with compliance measured at Monitoring Location EFF-001 as described in the Monitoring and Reporting Program, Attachment E.

Table 4. Final Effluent Limitations

Parameter	Units	Effluent Limitations			
		Average Monthly	Maximum Daily	Instantaneous Minimum	Instantaneous Maximum
pH	standard units	--	--	6.5	8.5
Fluoride, Total	mg/L	--	0.44	--	--
Manganese, Total Recoverable	µg/L	50	100	--	--
Formaldehyde	mg/L	0.65	1.3	--	--
Hydrogen Peroxide	mg/L	--	1.3	--	--
Potassium Permanganate	mg/L	0.031	0.062	--	--
Settleable Solids	ml/L	0.1	--	--	--
Total Suspended Solids (TSS)	mg/L	6.0	--	--	15

2. Interim Effluent Limitations – Not Applicable

B. Land Discharge Specifications – Not Applicable

C. Recycling Specifications – Not Applicable

V. RECEIVING WATER LIMITATIONS

Receiving water limitations are based on water quality objectives contained in the Basin Plan and are a required part of this Order. Compliance with numeric receiving water limitations shall be measured at Monitoring Location EFF-001. The discharge shall not cause the following in the Mojave River:

A. Surface Water Limitations

1. This Discharger shall not cause a violation of any applicable water quality standard for receiving water adopted by the Lahontan Water Board or the State Water Board as required by the federal Water Pollution Control Act and regulations adopted thereunder. If more stringent applicable water quality standards are promulgated or approved

pursuant to section 303 of the federal Clean Water Act or amendments thereto, the Lahontan Water Board may revise and modify this Order in accordance with such more stringent standards.

2. **Ammonia.** The neutral, unionized ammonia species (NH_3) is highly toxic to freshwater fish. The fraction of toxic NH_3 to total ammonia species ($\text{NH}_4^+ + \text{NH}_3$) is a function of temperature and pH. Basin Plan Tables 5.1-5 to 5.1-6 were derived from USEPA ammonia criteria for freshwater. Ammonia concentrations shall not exceed the values listed for the corresponding conditions in these tables. For temperature and pH values not explicitly in the tables, the most conservative value neighboring the actual value may be used or criteria can be calculated from numerical formulas developed by the USEPA.
3. **Bacteria, Coliform.** Waters shall not contain concentrations of coliform organisms attributable to anthropogenic sources, including human and livestock wastes. The fecal coliform concentration during any 30-day period shall not exceed a log mean of 20 MPN/100 mL, nor shall more than 10 percent of all samples collected during any 30-day period exceed 40 MPN/100 mL. The USEPA recommends that the log mean should ideally be based on a minimum of not less than five samples collected as evenly spaced as practicable during any 30-day period. [Reference: Ambient Water Quality Criteria for Bacteria - 1986, EPA 440/5-84-002, page 2.] However, a log mean concentration exceeding 20 MPN/100 mL for any 30-day period shall indicate violation of this objective even if fewer than five samples were collected.
4. **Biostimulatory Substances.** Waters shall not contain biostimulatory substances in concentrations that promote aquatic growths to the extent that such growths cause nuisance or adversely affect the water for beneficial uses.
5. **Chemical Constituents.** Waters shall not contain concentrations of chemical constituents in amounts that adversely affect the water for beneficial uses.
 - a. The receiving waters have been designated as municipal and domestic supply (MUN) and shall not contain concentrations of chemical constituents in excess of the maximum contaminant level (MCL) or secondary maximum contaminant level (SMCL) established for drinking water and specified in Title 22 of the California Code of Regulations, which are incorporated by reference into this Order: Table 64431-A (MCLs for Inorganic Chemicals), Table 64444-A (MCLs for Organic Chemicals), Table 64449-A (Secondary MCLs, Consumer Acceptance Limits), and Table 64449-B (Secondary MCLs, Ranges). This incorporation-by-reference is prospective and therefore includes future changes to the incorporated provisions, as changes take effect.
 - b. Waters designated as agricultural supply (AGR) shall not contain concentrations of chemical constituents in amounts that adversely affect the water for beneficial uses (i.e., agricultural purposes).
6. **Chlorine, Total Residual.** For the protection of aquatic life, total chlorine residual shall not exceed either a median value of 0.002 mg/L or a maximum value of 0.003 mg/L. Median values shall be based on daily measurements taken within any 6-month period.
7. **Color.** Waters shall be free of coloration that causes nuisance or adversely affects the water for beneficial uses.
8. **Dissolved Oxygen.** The dissolved oxygen concentration, as percent saturation, shall not be depressed by more than 10 percent, nor shall the minimum dissolved oxygen concentration be less than 80 percent of saturation. For waters with the beneficial uses

of COLD, COLD with SPWN, WARM, and WARM with SPWN, the minimum dissolved oxygen concentration shall not be less than that specified in Table 3-6 of the Basin Plan.

- 9. **Floating Materials.** Waters shall not contain floating materials, including solids, liquids, foams, and scum, in concentrations that cause nuisance or adversely affect the water for beneficial uses. For natural high quality waters, the concentrations of floating material shall not be altered to the extent that such alterations are discernible at the 10 percent significance level.
- 10. **Nondegradation of Aquatic Communities and Populations.** All wetlands shall be free of substances attributable to wastewater or other discharges that produce adverse physiological responses in humans, animals, or plants; or that lead to the presence of undesirable or nuisance aquatic life. All wetlands shall be free from activities that would substantially impair the biological community as it naturally occurs due to physical, chemical and hydrologic processes.
- 11. **Oil and Grease.** Waters shall not contain oils, greases, waxes or other materials in concentrations that result in a visible film or coating on the surface of the water or on objects in the water, that cause nuisance, or that otherwise adversely affect the water for beneficial uses. For natural high quality waters, the concentration of oils, greases, or other film or coat generating substances shall not be altered.
- 12. **pH.** Changes in normal ambient pH levels shall not exceed 0.5 pH units. The pH shall not be depressed below 6.5 nor raised above 8.5.

The Lahontan Water Board recognizes that some waters of the Region may have natural pH levels outside of the 6.5 to 8.5 range. Compliance with the pH objective for these waters will be determined on a case-by-case basis.

- 13. **Radioactivity.** Radionuclides shall not be present in concentrations that are deleterious to human, plant, animal, or aquatic life or that result in the accumulation of radionuclides in the food web to an extent that presents a hazard to human, plant, animal, or aquatic life. Waters shall not contain concentrations of radionuclides in excess of limits listed in the subsequent table as specified in Title 22 of the California Code of Regulations:

Table 5. Receiving Water Limitations for Radionuclides

Constituent	Limit (pCi/L)
Radioactivity, Gross Alpha	15
Radium-226 + Radium-228	5

- 14. **Sediment.** The suspended sediment load and suspended sediment discharge rate of surface waters shall not be altered in such a manner as to cause nuisance or adversely affect the water for beneficial uses.
- 15. **Settleable Materials.** Waters shall not contain substances in concentrations that result in deposition of material that causes nuisance or that adversely affects the water for beneficial uses. For natural high quality waters, the concentration of settleable materials shall not be raised by more than 0.1 ml/L.
- 16. **Suspended Material.** Waters shall not contain suspended materials in concentrations that cause nuisance or that adversely affect the water for beneficial uses. For natural high quality waters, the concentration of total suspended materials shall not be altered to the extent that such alterations are discernible at the 10 percent significance level.
- 17. **Taste and Odor.** Waters shall not contain taste or odor-producing substances in concentrations that impart undesirable tastes or odors to fish or other edible products of

aquatic origin, that cause nuisance, or that adversely affect the water for beneficial uses. For naturally high quality waters, the taste and odor shall not be altered.

- 18. Temperature.** The natural receiving water temperature of all waters shall not be altered unless it can be demonstrated to the satisfaction of the Lahontan Water Board that such an alteration in temperature does not adversely affect the water for beneficial uses. For waters designated WARM, water temperature shall not be altered by more than 5 degrees Fahrenheit (5°F) above or below the natural temperature. For waters designated COLD, the temperature shall not be altered.

[Note: The Basin Plan does not specify which reaches of the Mojave River have a COLD or WARM beneficial use. Therefore, the most restrictive standard (i.e., no alteration of temperature for the COLD use) applies. However, for purposes of compliance and enforcement, the Lahontan Water Board will consider historical data and the impact of temperature alterations upon the beneficial uses of the Mojave River below Discharge Point 001.]

- 19. Toxicity.** All waters shall be maintained free of toxic substances in concentrations that are toxic to, or that produce detrimental physiological responses in human, plant, animal, or aquatic life. Compliance with this objective will be determined by use of indicator organisms; analyses of species diversity, population density, growth anomalies, bioassays of appropriate duration and/or other appropriate methods as specified by the Lahontan Water Board.

The survival of aquatic life in surface waters subjected to a waste discharge, or other controllable water quality factors, shall not be less than that for the same water body in areas unaffected by the waste discharge, or when necessary, for other control water that is consistent with the requirements for "experimental water" as defined in *Standard Methods for the Examination of Water and Wastewater* (American Public Health Association, et al. 2012 or subsequent editions).

- 20. Turbidity.** Waters shall be free of changes in turbidity that cause nuisance or adversely affect the water for beneficial uses. Increases in turbidity shall not exceed natural levels by more than 10 percent.

- 21. Specific Numeric Receiving Water Limitations.** Surface receiving water limitations for the Mojave River at the Lower Narrows and at Victorville in Table 6 are based on Tables 3-20 and 3-21 (pages 3-54 and 3-56 through 3-57) of the Basin Plan. These limitations apply to surface waters tributary to the Mojave River above the Lower Narrows and to the shallow groundwater in the vicinity of and beneath the Mojave River channel. Discharges from the Facility shall not cause or contribute to exceedances of the following limitations:

Table 6. Surface Water Limitations

Constituent	Limit (mg/L)		
	Annual Average	90 th Percentile	Instantaneous Maximum
Total Dissolved Solids (TDS)	--	--	312
Nitrate (NO ₃) as Nitrate-Nitrogen	--	--	5
Chloride	75	100	--
Sulfate	40	100	--
Fluoride	0.2	1.5	--
Boron	0.2	0.3	--

B. Groundwater Limitations

Shallow groundwater adjacent to the Mojave River is highly influenced by the river. As such, the limitations for this shallow groundwater are the same as those in section V.A, above.

VI. PROVISIONS

A. Standard Provisions

1. The Discharger shall comply with all Standard Provisions included in Attachment D.
2. The Discharger shall comply with the following provisions. In the event that there is any conflict, duplication, or overlap between provisions specified by this Order, the more stringent provision shall apply:
 - a. Surface waters as used in this Order include, but are not limited to, wetlands and live streams, either perennial or ephemeral, which flow in natural or artificial watercourses, and natural lakes and artificial impoundments of waters within the State of California.
 - b. Groundwaters as used in this Order include, but are not limited to, all subsurface waters being above atmospheric pressure, and the capillary fringe of these waters.
 - c. The requirements prescribed herein do not authorize the commission of any act causing injury to the property of another, nor protect the Discharger from liabilities under federal, state, or local laws, nor guarantee the Discharger a capacity right in the receiving waters.
 - d. All discharges authorized by this Order shall be consistent with the terms and conditions of this Order. The discharge of any pollutant more frequently than, or at a level in excess of, that identified and authorized by this Order shall constitute a violation of the terms and conditions of this Order.
 - e. Pursuant to Water Code section 13263, subdivision (g), no discharge of waste into the waters of the state, whether or not the discharge is made pursuant to waste discharge requirements, shall create a vested right to continue the discharge. All discharges of waste into waters of the state are privileges, not rights.
 - f. Failure to comply with this permit may constitute a violation of the Water Code and/or the CWA, and is grounds for enforcement action or for permit termination, revocation and re-issuance, or modification.
 - g. The Discharger shall take all reasonable steps to minimize or prevent any discharge in violation of this permit that has a reasonable likelihood of adversely affecting human health or the environment.
 - h. The Water Code and the CWA provide for civil liability and criminal penalties for violations of the permit limits including imposition of civil liability or referral to the Attorney General.
 - i. A copy of the NPDES permit shall be kept and maintained by the Discharger and be available at all times to operating personnel.
 - j. Provisions of the permit are severable. If any provision of the requirements is found invalid, the remainder of the requirements shall not be affected.
 - k. In the event the Discharger is unable to comply with any of the conditions of this Order due to:

- i. breakdown or serious malfunction of water treatment equipment;
- ii. accidents caused by human error or negligence;
- iii. overflows from the system; or
- iv. other causes such as acts of nature,

the Discharger shall notify the Lahontan Water Board Executive Officer as soon as the Discharger or the Discharger's agents have knowledge of any discharge in violation of this permit, or any emergency discharge or other discharge of water to the Mojave River or surrounding wetland areas, in accordance with the notification requirements in the Standard Provisions for NPDES Permits, included in this Order as Attachment D, and with Water Code sections 13267 and 13383.

- l. Pursuant to Water Code section 13267, subdivision (b), the Discharger shall notify the Lahontan Water Board of any substantial change in the volume or character of pollutants introduced into the Facility from the conditions existing at the time of adoption of this NPDES permit.
- m. Adequate notice shall include information on the quality and quantity of effluent discharged into the receiving waters for the Facility, as well as any anticipated impact of the change on the quantity or quality of the effluent to be discharged from the Facility. A substantial change in volume is considered an increase in excess of ten percent of the mean daily flow rate. The Discharger shall forward a copy of such notice directly to the USEPA Regional Administrator.
- n. The Discharger shall file a report of waste discharge with the Lahontan Water Board at least 180 days before making any material change or proposed change in the character, location, or volume of the discharge.
- o. Pursuant to Water Code section 13260, subdivision (c), any change in the ownership and/or operation of property subject to the NPDES permit shall be reported to the Lahontan Water Board. Notification of applicable NPDES Permit requirements shall be furnished in writing to the new owners and/or operators, and a copy of such notification shall be sent to the Lahontan Water Board.
- p. If a Discharger becomes aware that any information submitted to the Lahontan Water Board is incorrect, the Discharger shall immediately notify the Lahontan Water Board, in writing, and correct that information.
- q. If the Discharger becomes aware that its NPDES permit is no longer needed (because the discharge will cease), the Discharger shall notify the Lahontan Water Board in writing and request that the permit be rescinded.
- r. Failure to comply with provisions or requirements of this Order, or violation of other applicable laws or regulations governing discharges from this facility, may subject the Discharger to administrative or civil liabilities, criminal penalties, and/or other enforcement remedies to ensure compliance. Additionally, certain violations may subject the Discharger to civil or criminal enforcement from appropriate local, state, or federal law enforcement entities.
- s. In the event the Discharger does not comply or will be unable to comply for any reason, with any prohibition, maximum daily effluent limitation, average monthly effluent limitation, or receiving water limitation of this Order, the Discharger shall notify the Lahontan Water Board by telephone [(530) 542-5400] within 24 hours of having knowledge of such noncompliance, and shall confirm this notification in writing within five days, unless the Lahontan Water Board waives confirmation. The

written notification shall state the nature, time, duration, and cause of noncompliance, and shall describe the measures being taken to remedy the current noncompliance and prevent recurrence including, where applicable, a schedule of implementation. Other noncompliance requires written notification as above at the time of the normal monitoring report.

- t. Reports required by this Order, and other information requested by the Lahontan Water Board, must be signed by a duly-authorized representative of the Discharger. Under Water Code sections 13268 and 13383, any person failing or refusing to furnish technical or monitoring reports or falsifying any information provided therein, is guilty of a misdemeanor and may be liable civilly in an amount of up to ten thousand dollars (\$10,000) for each violation.

B. Monitoring and Reporting Program (MRP) Requirements

The Discharger shall comply with the MRP and future revisions thereto, in Attachment E.

C. Special Provisions

1. Reopener Provisions

- a. If more stringent applicable water quality standards are promulgated or approved pursuant to section 303 of the Federal Water Pollution Control Act or amendments thereto, the Lahontan Water Board may revise and modify this Order in accordance with such more stringent standards.
- b. The Lahontan Water Board may reopen this Order to establish new conditions or effluent limitations should monitoring data, toxicity testing data, or other new information indicate that a constituent is discharged at a level that will do any of the following:
 - i. cause, have reasonable potential to cause, or contribute to an in-stream excursion above any water quality criteria or objective, or
 - ii. cause, have reasonable potential to cause, or contribute to a violation of any narrative water quality objective contained in the Basin Plan.
- c. **Effluent Limitations Based on New Information.** If toxicity testing, or information specified below in Section VI.C.2 of this Order, or the drug and chemical use reporting required in the Monitoring and Reporting Program (Attachment E) indicates that any drug or chemical is, or may be, discharged at a level that will cause, have the reasonable potential to cause, or contribute to an in-stream excursion above any chemical-specific water quality criteria or objective, narrative water quality objective for chemical constituents from the Basin Plan, or narrative water quality objective for toxicity from the Basin Plan, this Order may be reopened to establish effluent limitations.
- d. **Toxicity Test Exposure Times.** Toxicity testing requirements, as specified in Section VI.C.2. of this Order, are based on exposure times of 48 or 96 hours. If the Discharger provides sufficient justification that shorter exposure times are a closer approximation of actual exposure times, then this Order may be reopened to account for shorter exposure times.
- e. **Intake Water Credits.** The Discharger submitted information as detailed in section 1.4.4 of the SIP demonstrating that the required conditions are met for intake water credits. As the SIP conditions were met, the Lahontan Water Board included effluent limitations based on the 99th percentile value representing the upper range of the variability between intake and effluent pollutant concentrations due to sampling and

analysis variability. To the extent that the characteristics of the influent (and subsequently the effluent) change, the effluent limitations specified in this Order may be modified if new information is submitted by the Discharger to the Lahontan Water Board.

2. Special Studies, Technical Reports and Additional Monitoring Requirements

a. Chemical and Aquaculture Drug Use

Attachment G of this Order lists all aquaculture drugs and chemicals that may potentially be used at the Facility, as well as expected application methods and dosages. This Order authorizes the use of acetic acid, amoxicillin trihydrate, carbon dioxide, Chloramine-T, Chorulon®, Epsom salt, erythromycin, florfenicol, formalin, hydrogen peroxide, Ivermectin, MS-222, Ovaplant®, oxytetracycline hydrochloride, oxytetracycline dihydrate, penicillin G, potassium permanganate, PVP Iodine, SLICE, sodium bicarbonate, sodium chloride, Romet-30, vibrio vaccine (fish are removed via a basket, dipped in vaccine, and then returned to the raceway), and enteric redmouth bacterin (fish are removed via a basket, dipped in vaccine, and then returned to the raceway) in accordance with label directions, effluent limitations, BMP Plan requirements, monitoring and reporting requirements, and other conditions of this Order.

Other aquaculture chemicals or drugs that may be used at the Facility can only be authorized if the Discharger notifies the Lahontan Water Board in writing of the intent to use a new drug or chemical. The notification shall contain the following supplemental information:

- i. The common name(s) and active ingredient(s) of the drug or chemical proposed for use and discharge.
- ii. The purpose for the proposed use of the drug or chemical (i.e., list the specific disease for treatment and specific species for treatment).
- iii. The amount proposed for use or disposal, and the resulting calculated estimate of concentration in the discharge. Calculations used to derive estimated concentrations must also be submitted.
- iv. The location, duration, and frequency of the proposed use or disposal.
- v. Material safety data sheets and available toxicity information.
- vi. Any related Investigational New Animal Drug (INAD), New Animal Drug Application (NADA) information, extra-label use requirements and/or veterinarian prescriptions.
- vii. The Discharger shall also submit acute toxicity test information on any new chemical or drug applied in solution for immersive treatment (i.e., immersion bath, "drip" treatment, flush treatment) in accordance with methods specified in the USEPA *Methods for Measuring the Acute Toxicity of Effluents and Receiving Waters to Freshwater and Marine Organisms* (EPA 600/4-90/027) using *Ceriodaphnia dubia* (*C. dubia*) to determine the No Observed Adverse Effect Level (NOAEL) and Lowest Observed Adverse Effect Level (LOAEL).

Where exposure of aquatic life to any aquaculture drug or chemical may be long-term or continuous, the Discharger also shall conduct and/or submit the results of chronic toxicity testing in accordance with EPA/21-R-02-013, *Short Term Methods for Estimating the Chronic Toxicity of Effluents and Receiving Waters to Freshwater Organisms, Fourth Edition, October 2002*, using

C. dubia, to determine the No Observed Effect Concentration (NOEC) or Inhibition Concentration (IC₂₅).

b. Reporting of Unanticipated Discharges

- i. The Discharger shall provide to the Lahontan Water Board an oral report within 24 hours of discovery of the failure in, or damage to, the settling pond (effluent treatment system) or an aquatic animal containment system resulting in an unanticipated material discharge of pollutants to waters of the United States or State. The Discharger must describe the cause of the failure or damage to the containment system and identify materials that have been released to the environment as a result of this failure/damage.
- ii. The Discharger must provide a written report within 7 days of discovery of the failure or damage, documenting the cause, the estimated time that elapsed before the failure or damage was repaired, an estimate of the material released as a result of the failure or damage, and steps being taken to prevent a reoccurrence.
- iii. In the event of a spill of drugs, chemicals, pesticides, or feed that results in a discharge to waters of the United States or State, the Discharger must provide an oral report of the spill to the Lahontan Water Board within 24 hours of discovery of its occurrence and a written report within 7 days. The report shall include the identity and quantity of the material spilled.

3. Best Management Practices and Pollution Prevention

a. Best Management Practices (BMP) Plan – Aquaculture Operations

The Discharger shall certify in writing to the Lahontan Water Board no later than **October 2, 2017** that the BMP Plan has been updated to include the requirements specified in this Order and is being implemented as required by 40 C.F.R. section 451.3(d). The existing BMP Plan may be modified for use under this section. The Discharger shall develop and implement the BMP Plan to prevent or minimize the generation and discharge of wastes and pollutants to waters of the United States and State and ensure disposal or land application of wastes is in compliance with applicable solid waste disposal regulations. The Discharger shall consider the recommendations provided in USEPA's March 2006 Compliance Guide for the Concentrated Aquatic Animal Production Point Source Category (EPA-821-B-05-001) when updating the BMP Plan. The Discharger shall review and certify in writing to the Lahontan Water Board the BMP Plan annually (by **February 1** of each year) and must amend the BMP Plan whenever there is a change in the Facility or in the operation of the Facility which materially increases the generation of pollutants or their release or potential release to surface waters.

The BMP plan must include, at a minimum, the following BMPs:

i. Solids Management

- (a) Conduct fish feeding in a manner that limits feed input to the minimum amount reasonably necessary to achieve production goals and sustain targeted rates of aquatic animal growth and minimizes the discharge of unconsumed food and waste products to surface waters.
- (b) Clean aquaculture raceways and settling pond using procedures and at frequencies that minimize the disturbance and subsequent discharge of accumulated solids during routine activities such as inventorying, grading,

and harvesting. Include procedures to remove bryozoans using peracetic acid. The procedures shall ensure there is no discharge of peracetic acid, bryozoans, or solid matter.

- (c) Report the final disposition of all other solids and liquids, including aquaculture drugs and chemicals, not discharged to surface waters in the effluent.
- (d) Remove and properly dispose of fish mortalities on a regular basis to prevent discharge to waters of the United States, except in cases where the discharge to surface waters is determined to benefit the aquatic environment. Procedures must be identified and implemented to collect, store, and dispose of fish and other solid wastes in an environmentally safe manner and in a manner so as to minimize discharge to waters of the United States or waters of the State.

ii. Operations and Maintenance

- (a) Maintain the Facility to prevent the overflow of any floating matter or bypassing of the settling pond.
- (b) Inspect the Facility and the settling pond on a routine basis in order to identify and promptly repair any damage.
- (c) Ensure storage and containment of drugs, chemicals, fuel, waste oil, organic wastes, pesticides/biocides/herbicides, or other materials to prevent spillage or release into the Facility, waters of the United States, or waters of the State.
- (d) Implement procedures for properly containing, cleaning, and disposing of any spilled material.
- (e) Prevent fish from being released within the U.S. Food and Drug Administration (FDA) required withdrawal time of any drug or chemical with which they have been treated.
- (f) All drugs and pesticides must be used in accordance with applicable label directions (FIFRA or FDA), except under the following conditions, both of which must be reported in advance to the Executive Officer:
 - (1) Participation in Investigational New Animal Drug (INAD) studies, using established protocols; or
 - (2) Extra label drug use, as prescribed by a veterinarian.
- (g) Implement protocols to ensure that pesticides stored or used on site will not spill, drift, or transport by storm water into the discharge, into waters of the United States, or into waters of the State.
- (h) Limit the number of raceways treated during chemical treatments to ensure compliance with effluent limitations and provisions of this Order.

iii. Recordkeeping

- (a) Maintain records for aquatic animal rearing units documenting the feed amounts and estimates of the numbers and weight of aquatic animals in order to calculate representative feed conversion ratios using the Feed Conversion Ratios Log provided in Attachment K of this Order.

- (b) Maintain records documenting the frequency of cleaning, inspections, maintenance, repairs, spills, and spill response.
- (c) Maintain records documenting compliance with training requirements.

iv. Training

- (a) Adequately train all relevant Facility personnel in spill prevention and how to respond in the event of a spill in order to ensure the proper clean-up and disposal of spilled material.
- (b) Train staff on the proper operation and cleaning of production and wastewater treatment systems, including training in feeding procedures and proper use of equipment.
- (c) The Discharger shall ensure that its operations staff are familiar with the BMP Plan and have been adequately trained in the specific procedures it requires.

b. Storm Water Pollution Prevention Plan (SWPPP)

Storm water runoff and infiltration of storm water at the Facility has the potential to come in contact with pollutants directly associated with aquaculture activities and secondary activities such as, but not limited to: vehicle maintenance, transportation of fish, construction, maintenance of structures on the Facility, or outdoor storage of unused or salvaged items. Pollutants that may come in contact with storm water and discharge to waters of the State in runoff or infiltration to groundwater include, but are not limited to, chemicals, fuel, waste oil, vehicle wash water, cleaning solutions, landscaping supplies, landscaping wastes, and storage of other materials with the potential for discharge to surface waters. The Discharger shall develop, and implement in accordance with the requirements in Attachment I, a SWPPP that describes site-specific BMPs for minimizing contamination of storm water runoff and for preventing contaminated storm water runoff from being discharged directly to waters of the State. The SWPPP must be reviewed at least annually, in accordance with Attachment I, and updated to represent current site conditions.

4. Construction, Operation and Maintenance Specifications

- a. Collected screenings, sludges, and other solids, including fish carcasses, shall be disposed of in a manner approved by the Executive Officer and consistent with Consolidated Regulations for Treatment, Storage, Processing, or Disposal of Solid Waste, as set forth in Title 27, CCR, Division 2, Subdivision 1, Section 20005, et seq.
- b. All aquaculture drugs and chemicals not discharged to receiving waters in accordance with the provisions of this Order shall be disposed of in an environmentally safe manner, according to label guidelines, Material Safety Data Sheet guidelines and the Discharger's BMP Plan (see Section VI.C.3.a of this Order). Any other form of disposal requires approval from the Executive Officer. For all aquaculture drugs and chemicals not authorized for discharge to receiving waters, the disposal onto permeable ground, or in any manner or in quantities that may result in a discharge to surface water or to groundwater, is prohibited (see also Section III, Discharge Prohibitions).
- c. All facilities used for transport and treatment of hatchery wastewater shall be adequately protected against either structural damage or significant reduction in

efficiency resulting from a storm or flood having a recurrence interval of once in 100 years.

- d. Solid waste, including fish mortalities, shall be discharged only at a legal point of disposal in accordance or in a manner approved by the Executive Officer.
- e. The vertical distance between the water surface elevation and the lowest point of a pond dike or the invert of an overflow structure shall not be less than 2 feet (0.46 meters).
- f. This Order authorizes the Discharger to discharge up to 1,000 gallons of recirculated water from the recirculated water aeration tower to the adjacent drainage ditch. The Discharger shall ensure drainage of the aeration tower occurs during dry weather conditions in a manner that ensures percolation within 100 feet and minimizes erosion within the drainage channel. The Discharger shall report the date(s) when drainage occurs and the total volume of drainage water discharged in the Annual Report.

- 5. **Special Provisions for Municipal Facilities (POTWs Only) – Not Applicable**
- 6. **Other Special Provisions – Not Applicable**
- 7. **Compliance Schedules – Not Applicable**

VII. COMPLIANCE DETERMINATION

Compliance with the effluent limitations contained in Section IV of this Order will be determined as specified below:

A. Limitation Bases

1. Average Monthly Effluent Limitation (AMEL)

If the average of daily discharges over a calendar month exceeds the AMEL for a given parameter, this will represent a single violation, though the Discharger will be considered out of compliance for each day of that month for that parameter (e.g., resulting in 31 days of non-compliance in a 31-day month). If only a single sample is taken during the calendar month and the analytical result for that sample exceeds the AMEL, the Discharger will be considered out of compliance for that calendar month. The Discharger will only be considered out of compliance for days when the discharge occurs. For any one calendar month during which no sample (daily discharge) is taken, no compliance determination can be made for that calendar month. The Discharger will calculate and report the net effluent over influent concentration as necessary for constituents with Intake credits. Additional samples, above specified minimum, may be collected to demonstrate compliance.

2. Maximum Daily Effluent Limitation (MDEL)

If a daily discharge exceeds the MDEL for a given parameter, the Discharger will be considered out of compliance for that parameter for that one day only within the reporting period. For any one day during which no sample is taken, no compliance determination can be made for that calendar day.

3. Instantaneous Minimum Effluent Limitation

If the analytical result of a single grab sample is lower than the instantaneous minimum effluent limitation for a parameter, the Discharger will be considered out of compliance for that parameter for that single sample. Non-compliance for each sample will be considered separately (e.g., the results of two grab samples taken at different times

within a calendar day that both are lower than the instantaneous minimum effluent limitation would result in two instances of non-compliance with the instantaneous minimum effluent limitation). Duplicate samples taken at the same time and location for QA/QC purposes will not be subject to duplicate fines. QA/QC includes splitting a sample and/or collection of duplicate samples for analysis by a different laboratory. Reanalysis of samples after re-calibration and maintenance of field test instruments will not be subject to duplicate fines.

4. Instantaneous Maximum Effluent Limitation

If the analytical result of a single grab sample is higher than the instantaneous maximum effluent limitation for a parameter, the Discharger will be considered out of compliance for that parameter for that single sample, unless the influent supply water equals or exceeds the instantaneous maximum effluent limitation. In that case, the effluent concentration may not exceed the influent supply water concentration, for those parameter listed in Table 4, Footnote 3, and for that sampling event only. Non-compliance for each sample will be considered separately (e.g., the results of two grab samples taken different times within a calendar day that both exceed the instantaneous minimum effluent limitation would result in two instances of non-compliance with the instantaneous maximum effluent limitation). Duplicate samples taken at the same time and location for QA/QC purposes will not be subject to duplicate fines. QA/QC includes splitting a sample and/or collection of duplicate samples for analysis by a different laboratory. Reanalysis of samples after re-calibration and maintenance of field test instruments will not be subject to duplicate fines. The Discharger will calculate and report whether the influent supply water concentration equals or exceeds the instantaneous maximum effluent limitation.

B. Point of Compliance for Effluent Limitations

This Order requires monitoring at a single monitoring location, Monitoring Location EFF-001, to determine compliance with effluent limitations at both Discharge Points 001 and 002. Although the Discharger discharges at two separate locations, a monitoring result collected at Monitoring Location EFF-001 that exceeds an effluent limitation in section IV.A.1 of this Order shall be considered a single effluent limitation violation.

ATTACHMENT A – DEFINITIONS

Arithmetic Mean (μ)

Also called the average, is the sum of measured values divided by the number of samples. For ambient water concentrations, the arithmetic mean is calculated as follows:

$$\text{Arithmetic mean} = \mu = \Sigma x / n \quad \text{where: } \Sigma x \text{ is the sum of the measured ambient water concentrations, and } n \text{ is the number of samples.}$$

Aquaculture Facility

A hatchery, fish farm, or other facility that contains, grows, or holds fish for later harvest (or process) and for sale or releases.

Average Monthly Effluent Limitation (AMEL)

The highest allowable average of daily discharges over a calendar month, calculated as the sum of all daily discharges measured during a calendar month divided by the number of daily discharges measured during that month.

Average Weekly Effluent Limitation (AWEL)

The highest allowable average of daily discharges over a calendar week (Sunday through Saturday), calculated as the sum of all daily discharges measured during a calendar week divided by the number of daily discharges measured during that week.

Best Management Practices (BMPs)

Schedules of activities, prohibitions of practices, maintenance procedures, and other management practices to prevent or reduce the pollution of surface waters. BMPs also include treatment requirements, operating procedures, and practices to control site runoff, spillage or leaks, and solids or waste disposal.

Bioaccumulative

Those substances taken up by an organism from its surrounding medium through gill membranes, epithelial tissue, or from food and subsequently concentrated and retained in the body of the organism.

Carcinogenic

Pollutants are substances that are known to cause cancer in living organisms.

Coefficient of Variation (CV)

CV is a measure of the data variability and is calculated as the estimated standard deviation divided by the arithmetic mean of the observed values.

Cold Water Species

Cold water aquatic animals include, but are not limited to, the *Salmonidae* family of fish, e.g., trout and salmon.

Concentrated Aquatic Animal Production (CAAP) Facility

Point Sources subject to the National Pollutant Discharge Elimination System (NPDES) permit program including those upland facilities that discharge for at least 30 days per year and contain, grow, or hold cold water fish species or other cold water aquatic animals except facilities which produce less than 9,000 harvest weight kilograms (approximately 20,000 pounds) of aquatic animals per year and facilities which feed less than 2,285 kilograms (approximately 5,000 pounds) of food during the calendar month of maximum feeding.

Daily Discharge

Daily Discharge is defined as either: (1) the total mass of the constituent discharged over the calendar day (12:00 am through 11:59 pm) or any 24-hour period that reasonably represents a calendar day for purposes of sampling (as specified in the permit), for a constituent with limitations expressed in units of mass or; (2) the unweighted arithmetic mean measurement of the constituent over the day for a constituent with limitations expressed in other units of measurement (e.g., concentration).

The daily discharge may be determined by the analytical results of a composite sample taken over the course of one day (a calendar day or other 24-hour period defined as a day) or by the arithmetic mean of analytical results from one or more grab samples taken over the course of the day.

For composite sampling, if 1 day is defined as a 24-hour period other than a calendar day, the analytical result for the 24-hour period will be considered as the result for the calendar day in which the 24-hour period ends.

Detected, but Not Quantified (DNQ)

DNQ are those sample results less than the RL, but greater than or equal to the laboratory's MDL. Sample results reported as DNQ are estimated concentrations.

Dilution Credit

Dilution Credit is the amount of dilution granted to a discharge in the calculation of a water quality-based effluent limitation, based on the allowance of a specified mixing zone. It is calculated from the dilution ratio or determined through conducting a mixing zone study or modeling of the discharge and receiving water.

Effluent Concentration Allowance (ECA)

ECA is a value derived from the water quality criterion/objective, dilution credit, and ambient background concentration that is used, in conjunction with the coefficient of variation for the effluent monitoring data, to calculate a long-term average (LTA) discharge concentration. The ECA has the same meaning as wasteload allocation (WLA) as used in USEPA guidance (Technical Support Document for Water Quality-based Toxics Control, March 1991, second printing, EPA/505/2-90-001).

Enclosed Bays

Enclosed Bays means indentations along the coast that enclose an area of oceanic water within distinct headlands or harbor works. Enclosed bays include all bays where the narrowest distance between the headlands or outermost harbor works is less than 75 percent of the greatest dimension of the enclosed portion of the bay. Enclosed bays include, but are not limited to, Humboldt Bay, Bodega Harbor, Tomales Bay, Drake's Estero, San Francisco Bay, Morro Bay, Los Angeles-Long Beach Harbor, Upper and Lower Newport Bay, Mission Bay, and San Diego Bay. Enclosed bays do not include inland surface waters or ocean waters.

Estimated Chemical Concentration

The estimated chemical concentration that results from the confirmed detection of the substance by the analytical method below the ML value.

Estuaries

Estuaries means waters, including coastal lagoons, located at the mouths of streams that serve as areas of mixing for fresh and ocean waters. Coastal lagoons and mouths of streams that are temporarily separated from the ocean by sandbars shall be considered estuaries. Estuarine waters shall be considered to extend from a bay or the open ocean to a point upstream where there is no significant mixing of fresh water and seawater. Estuarine waters included, but are not limited to, the Sacramento-San Joaquin Delta, as defined in Water Code section 12220, Suisun Bay, Carquinez Strait

downstream to the Carquinez Bridge, and appropriate areas of the Smith, Mad, Eel, Noyo, Russian, Klamath, San Diego, and Otay rivers. Estuaries do not include inland surface waters or ocean waters.

Extra Label Drug Use

A drug approved under the Federal Food, Drug, and Cosmetic Act that is not used in accordance with the approved label directions (see 21 C.F.R. part 530).

Inland Surface Waters

All surface waters of the state that do not include the ocean, enclosed bays, or estuaries.

Instantaneous Maximum Effluent Limitation

The highest allowable value for any single grab sample or aliquot (i.e., each grab sample or aliquot is independently compared to the instantaneous maximum limitation).

Instantaneous Minimum Effluent Limitation

The lowest allowable value for any single grab sample or aliquot (i.e., each grab sample or aliquot is independently compared to the instantaneous minimum limitation).

Investigational New Animal Drug (INAD)

A drug for which there is a valid exemption in effect under section 512(j) of the Federal Food, Drug, and Cosmetic Act, 21 U.S.C. 360(j), to conduct experiments.

Maximum Daily Effluent Limitation (MDEL)

The highest allowable daily discharge of a pollutant, over a calendar day (or 24-hour period). For pollutants with limitations expressed in units of mass, the daily discharge is calculated as the total mass of the pollutant discharged over the day. For pollutants with limitations expressed in other units of measurement, the daily discharge is calculated as the arithmetic mean measurement of the pollutant over the day.

Median

The middle measurement in a set of data. The median of a set of data is found by first arranging the measurements in order of magnitude (either increasing or decreasing order). If the number of measurements (n) is odd, then the median = $X_{(n+1)/2}$. If n is even, then the median = $(X_{n/2} + X_{(n/2)+1})/2$ (i.e., the midpoint between the n/2 and n/2+1).

Method Detection Limit (MDL)

MDL is the minimum concentration of a substance that can be measured and reported with 99 percent confidence that the analyte concentration is greater than zero, as defined in 40 C.F.R. part 136, Attachment B, revised as of July 3, 1999.

Minimum Level (ML)

ML is the concentration at which the entire analytical system must give a recognizable signal and acceptable calibration point. The ML is the concentration in a sample that is equivalent to the concentration of the lowest calibration standard analyzed by a specific analytical procedure, assuming that all the method specified sample weights, volumes, and processing steps have been followed.

Mixing Zone

Mixing Zone is a limited volume of receiving water that is allocated for mixing with a wastewater discharge where water quality criteria can be exceeded without causing adverse effects to the overall water body.

Not Detected (ND)

Sample results which are less than the laboratory's MDL.

Off-line Settling Basins

A constructed retention basin that receives wastewater from cleaning of aquaculture facility rearing/holding units, or quiescent zones, or both, for the retention and treatment of wastewater through settling of solids.

Persistent Pollutants

Persistent pollutants are substances for which degradation or decomposition in the environment is nonexistent or very slow.

Pollutant Minimization Program (PMP)

PMP means waste minimization and pollution prevention actions that include, but are not limited to, product substitution, waste stream recycling, alternative waste management methods, and education of the public and businesses. The goal of the PMP shall be to reduce all potential sources of a priority pollutant(s) through pollutant minimization (control) strategies, including pollution prevention measures as appropriate, to maintain the effluent concentration at or below the water quality-based effluent limitation. Pollution prevention measures may be particularly appropriate for persistent bioaccumulative priority pollutants where there is evidence that beneficial uses are being impacted. The Lahontan Water Board may consider cost effectiveness when establishing the requirements of a PMP. The completion and implementation of a Pollution Prevention Plan, if required pursuant to Water Code section 13263.3(d), shall be considered to fulfill the PMP requirements.

Pollution Prevention

Pollution Prevention means any action that causes a net reduction in the use or generation of a hazardous substance or other pollutant that is discharged into water and includes, but is not limited to, input change, operational improvement, production process change, and product reformulation (as defined in Water Code section 13263.3). Pollution prevention does not include actions that merely shift a pollutant in wastewater from one environmental medium to another environmental medium, unless clear environmental benefits of such an approach are identified to the satisfaction of the State Water Resources Control Board (State Water Board) or Lahontan Water Board.

Qualifying Rain Event

Any event that produces 0.5 inches or more precipitation. A rain event is defined as separate from a second rain event if at least 48 hours separates the two.

Reporting Level (RL)

The RL is the ML (and its associated analytical method) chosen by the Discharger for reporting and compliance determination from the MLs included in this Order, including an additional factor if applicable as discussed herein. The MLs included in this Order correspond to approved analytical methods for reporting a sample result that are selected by the Lahontan Water Board either from Appendix 4 of the SIP in accordance with section 2.4.2 of the SIP or established in accordance with section 2.4.3 of the SIP. The ML is based on the proper application of method-based analytical procedures for sample preparation and the absence of any matrix interferences. Other factors may be applied to the ML depending on the specific sample preparation steps employed. For example, the treatment typically applied in cases where there are matrix-effects is to dilute the sample or sample aliquot by a factor of ten. In such cases, this additional factor must be applied to the ML in the computation of the RL.

Source of Drinking Water

Any water designated as municipal or domestic supply (MUN) in a Lahontan Water Board Basin Plan.

Standard Deviation (σ)

Standard Deviation is a measure of variability that is calculated as follows:

$$\sigma = (\sum[(x - \mu)^2]/(n - 1))^{0.5}$$

where:

x is the observed value;

μ is the arithmetic mean of the observed values; and

n is the number of samples.

Toxicity Reduction Evaluation (TRE)

TRE is a study conducted in a step-wise process designed to identify the causative agents of effluent or ambient toxicity, isolate the sources of toxicity, evaluate the effectiveness of toxicity control options, and then confirm the reduction in toxicity. The first steps of the TRE consist of the collection of data relevant to the toxicity, including additional toxicity testing, and an evaluation of facility operations and maintenance practices, and best management practices. A Toxicity Identification Evaluation (TIE) may be required as part of the TRE, if appropriate. (A TIE is a set of procedures to identify the specific chemical(s) responsible for toxicity. These procedures are performed in three phases (characterization, identification, and confirmation) using aquatic organism toxicity tests.)

ATTACHMENT B – MAP

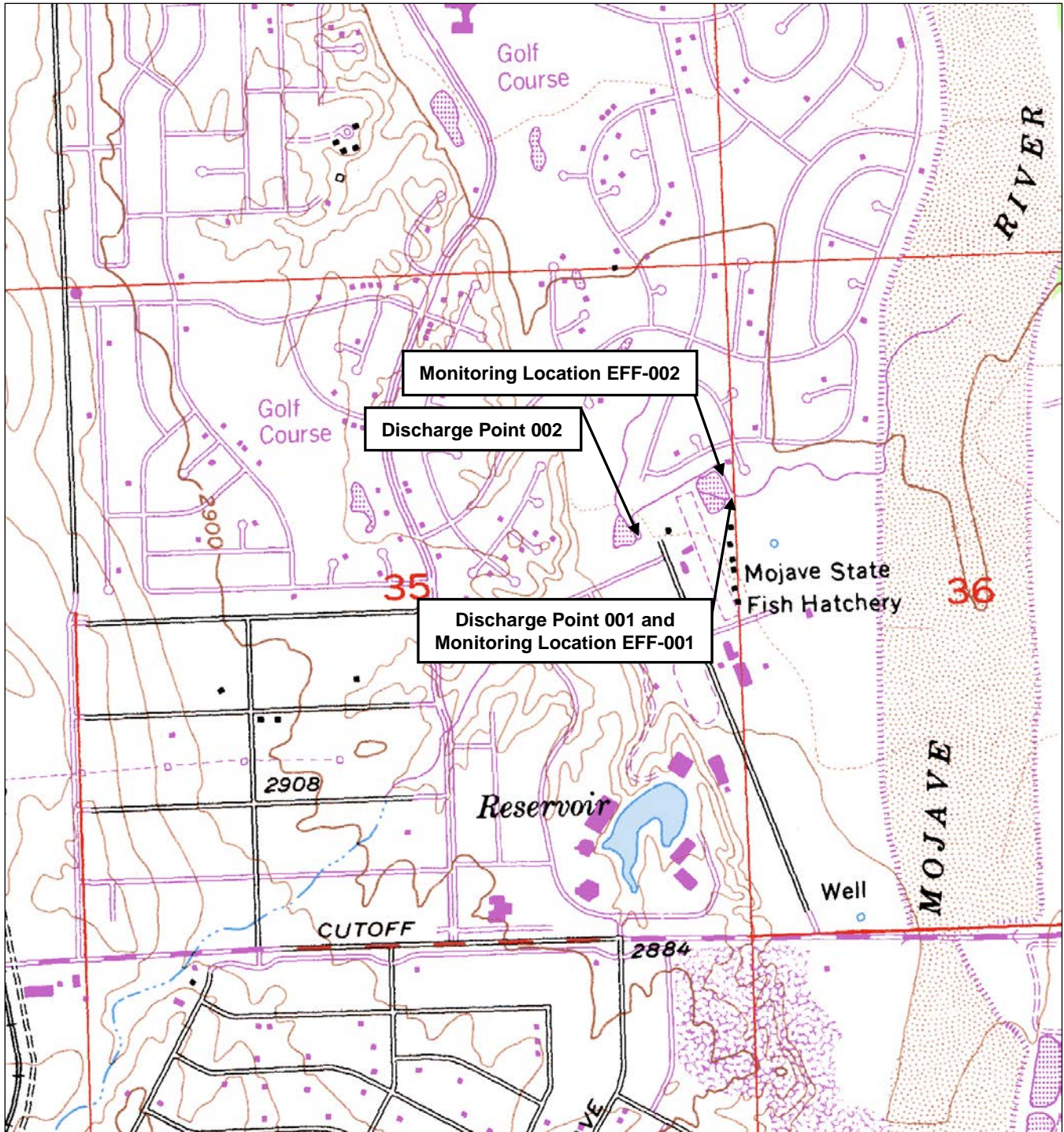

Mojave River Fish Hatchery
12550 Jacaranda Avenue
Victorville, CA 92395
San Bernardino County

Latitude: 34° 28' 45" N
Longitude: 117° 15' 38" W
Section 36, T5N, R4W, SBB&M
USGS Hesperia 7.5 Minute Quadrangle

ATTACHMENT C – FLOW SCHEMATIC

Figure C-1. Flow Schematic

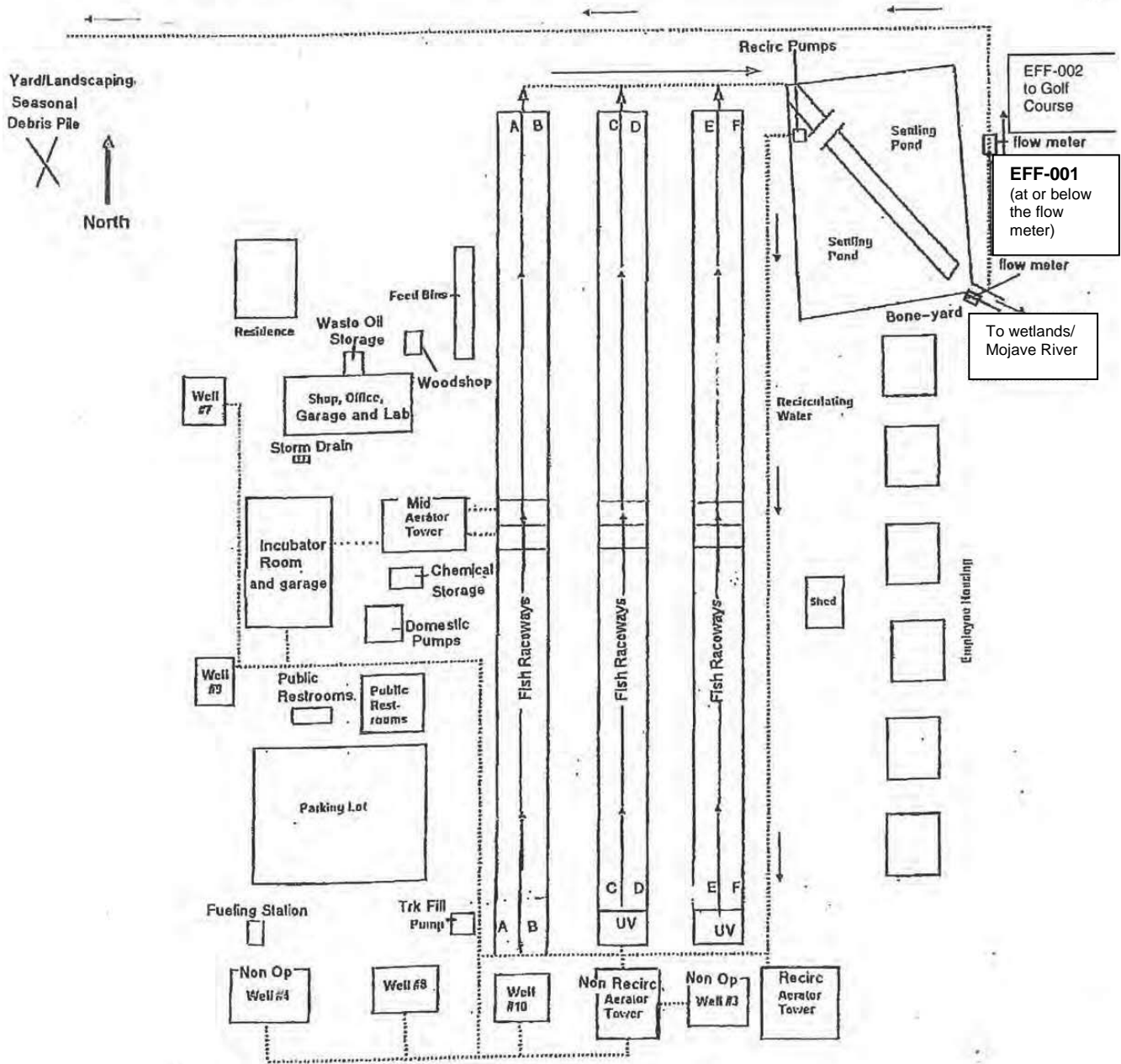

Figure C-2. Flow Diagram

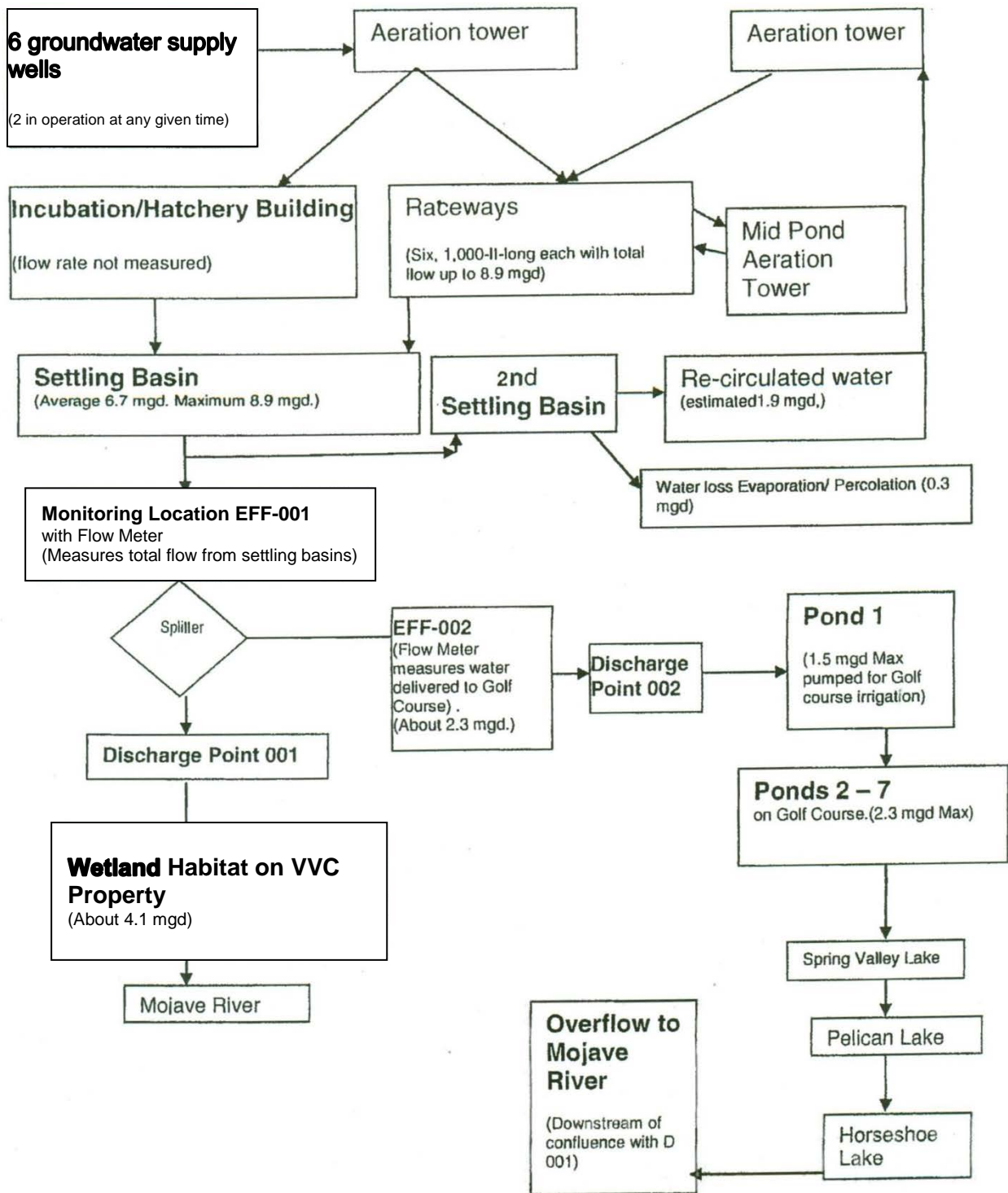
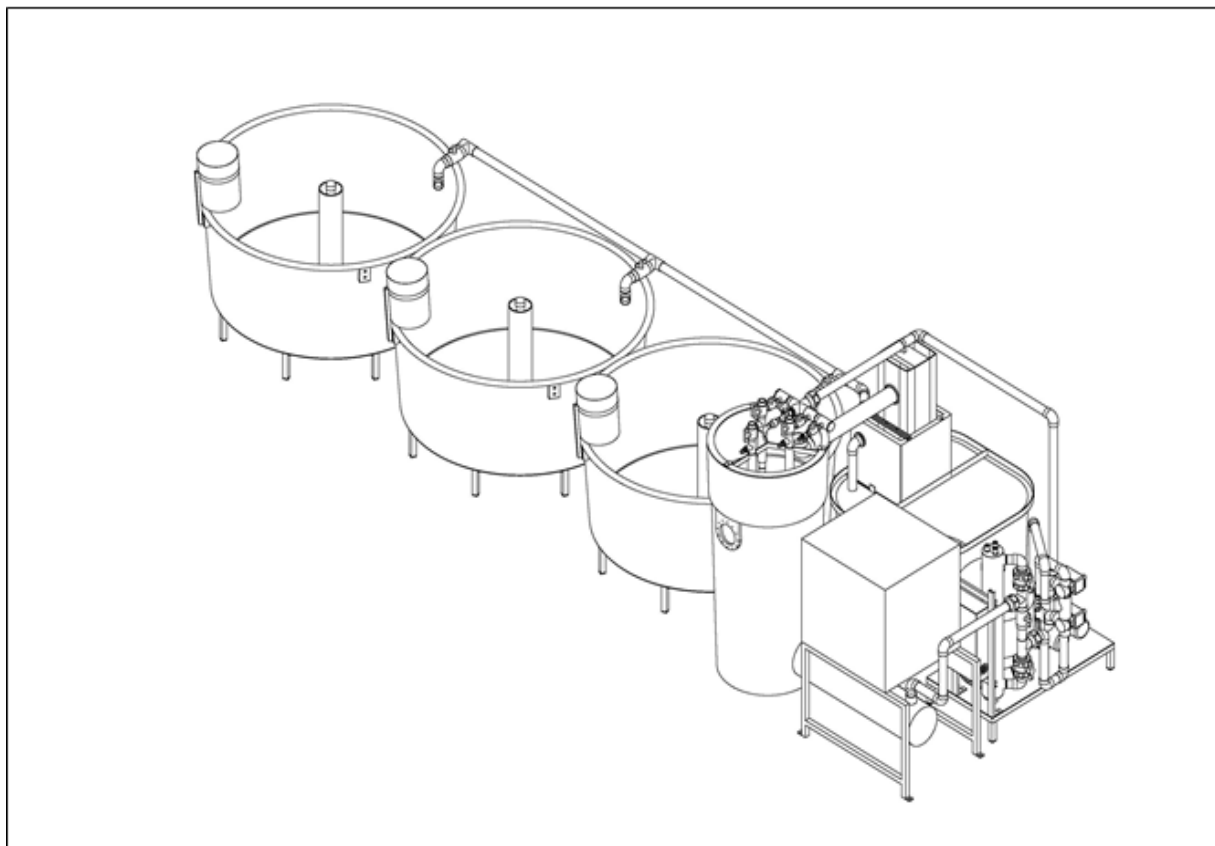

Figure C-3. Recirculating Aquaculture System Schematic



ATTACHMENT D – STANDARD PROVISIONS

I. STANDARD PROVISIONS – PERMIT COMPLIANCE

A. Duty to Comply

1. The Discharger must comply with all of the terms, requirements, and conditions of this Order. Any noncompliance constitutes a violation of the Clean Water Act (CWA) and the California Water Code and is grounds for enforcement action; permit termination, revocation and reissuance, or modification; denial of a permit renewal application; or a combination thereof. [40 C.F.R. § 122.41(a); Water Code sections 13261, 13263, 13265, 13268, 13000, 13001, 13304, 13350, and 13385.]
2. The Discharger shall comply with effluent standards or prohibitions established under Section 307(a) of the CWA for toxic pollutants and with standards for sewage sludge use or disposal established under section 405(d) of the CWA within the time provided in the regulations that establish these standards or prohibitions, even if this Order has not yet been modified to incorporate the requirement. [40 C.F.R. § 122.41(a)(1)]

B. Need to Halt or Reduce Activity Not a Defense

It shall not be a defense for a Discharger in an enforcement action that it would have been necessary to halt or reduce the permitted activity in order to maintain compliance with the conditions of this Order. [40 C.F.R. § 122.41(c)]

C. Duty to Mitigate

The Discharger shall take all reasonable steps to minimize or prevent any discharge or sludge use or disposal in violation of this Order that has a reasonable likelihood of adversely affecting human health or the environment. [40 C.F.R. § 122.41(d)]

D. Proper Operation and Maintenance

The Discharger shall at all times properly operate and maintain all facilities and systems of treatment and control (and related appurtenances) which are installed or used by the Discharger to achieve compliance with the conditions of this Order. Proper operation and maintenance also includes adequate laboratory controls and appropriate quality assurance procedures. This provision requires the operation of backup or auxiliary facilities or similar systems that are installed by a Discharger only when necessary to achieve compliance with the conditions of this Order. [40 C.F.R. § 122.41(e)]

E. Property Rights

1. This Order does not convey any property rights of any sort or any exclusive privileges. [40 C.F.R. § 122.41(g)]
2. The issuance of this Order does not authorize any injury to persons or property or invasion of other private rights, or any infringement of state or local law or regulations. [(40 C.F.R. § 122.5(c)]

F. Inspection and Entry

The Discharger shall allow the Lahontan Water Board, State Water Board, USEPA, and/or their authorized representatives (including an authorized contractor acting as their representative), upon the presentation of credentials and other documents, as may be required by law, to [33 U.S.C. § 1318(a)(4)(B)(i and ii); 40 C.F.R. § 122.41(i)(1 through 4); and Water Code sections 13267 and 13383]:

1. Enter upon the Discharger's premises where a regulated facility or activity is located or conducted, or where records are kept under the conditions of this Order;
2. Have access to and copy, at reasonable times, any records that must be kept under the conditions of this Order;
3. Inspect and photograph, at reasonable times, any facilities, equipment (including monitoring and control equipment), practices, or operations regulated or required under this Order; and
4. Sample or monitor, at reasonable times, for the purposes of assuring Order compliance or as otherwise authorized by the CWA or the Water Code, any substances or parameters at any location.

G. Bypass

1. Definitions

- a. "Bypass" means the intentional diversion of waste streams from any portion of a treatment facility. [40 C.F.R. § 122.41(m)(1)(i)]
- b. "Severe property damage" means substantial physical damage to property; damage to the treatment facilities, which causes them to become inoperable; or substantial and permanent loss of natural resources that can reasonably be expected to occur in the absence of a bypass. Severe property damage does not mean economic loss caused by delays in production. [40 C.F.R. § 122.41(m)(1)(ii)]

2. **Bypass not exceeding limitations.** The Discharger may allow any bypass to occur which does not cause exceedances of effluent limitations, but only if it is for essential maintenance to assure efficient operation. These bypasses are not subject to the provisions listed in Standard Provisions – Permit Compliance sections I.G.3, I.G.4, and I.G.5 below. [40 C.F.R. § 122.41(m)(2)]

3. **Prohibition of bypass.** Bypass is prohibited, and the Lahontan Water Board may take enforcement action against a Discharger for bypass, unless [40 C.F.R. § 122.41(m)(4)(i)(A through C)]:

- a. Bypass was unavoidable to prevent loss of life, personal injury, or severe property damage;
- b. There were no feasible alternatives to the bypass, such as the use of auxiliary treatment facilities, retention of untreated wastes, or maintenance during normal periods of equipment downtime. This condition is not satisfied if adequate back-up equipment should have been installed in the exercise of reasonable engineering judgment to prevent a bypass that occurred during normal periods of equipment downtime or preventive maintenance; and
- c. The Discharger submitted notice to the Lahontan Water Board as required under Standard Provisions – Permit Compliance section I.G.5 below.

4. The Lahontan Water Board may approve an anticipated bypass, after considering its adverse effects, if the Lahontan Water Board determines that it will meet the three conditions listed in Standard Provisions – Permit Compliance section I.G.3 above. [40 C.F.R. § 122.41(m)(4)(ii)]

5. Notice

- a. Anticipated bypass. If the Discharger knows in advance of the need for a bypass, it shall submit prior notice to the Lahontan Water Board, if possible at least 10 days before the date of the bypass. As of December 21, 2020, all notices must also be

submitted electronically to the initial recipient defined in Standard Provisions – Reporting section V.J below. Notices shall comply with 40 C.F.R. part 3, 40 C.F.R. section 122.22, and 40 C.F.R. part 127. [40 C.F.R. § 122.41(m)(3)(i)]

- b. Unanticipated bypass. The Discharger shall submit notice to the Lahontan Water Board of an unanticipated bypass as required in Standard Provisions – Reporting section V.E below (24-hour notice). As of December 21, 2020, all notices must also be submitted electronically to the initial recipient defined in Standard Provisions – Reporting section V.J below. Notices shall comply with 40 C.F.R. part 3, 40 C.F.R. section 122.22, and 40 C.F.R. part 127. [40 C.F.R. § 122.41(m)(3)(ii)]

H. Upset

Upset means an exceptional incident in which there is unintentional and temporary noncompliance with technology based permit effluent limitations because of factors beyond the reasonable control of the Discharger. An upset does not include noncompliance to the extent caused by operational error, improperly designed treatment facilities, inadequate treatment facilities, lack of preventive maintenance, or careless or improper operation. [40 C.F.R. § 122.41(n)(1).]

1. **Effect of an upset.** An upset constitutes an affirmative defense to an action brought for noncompliance with such technology based permit effluent limitations if the requirements of Standard Provisions – Permit Compliance I.H.2 below are met. No determination made during administrative review of claims that noncompliance was caused by upset, and before an action for noncompliance, is final administrative action subject to judicial review. [40 C.F.R. § 122.41(n)(2)]
2. **Conditions necessary for a demonstration of upset.** A Discharger who wishes to establish the affirmative defense of upset shall demonstrate, through properly signed, contemporaneous operating logs or other relevant evidence that [40 C.F.R. § 122.41(n)(3)(i through iv)]:
 - a. An upset occurred and that the Discharger can identify the cause(s) of the upset;
 - b. The permitted facility was, at the time, being properly operated;
 - c. The Discharger submitted notice of the upset as required in Standard Provisions – Reporting section V.E.2.b below (24-hour notice); and
 - d. The Discharger complied with any remedial measures required under Standard Provisions – Permit Compliance section I.C above.
3. **Burden of proof.** In any enforcement proceeding, the Discharger seeking to establish the occurrence of an upset has the burden of proof. [40 C.F.R. § 122.41(n)(4)]

II. STANDARD PROVISIONS – PERMIT ACTION

A. General

This Order may be modified, revoked and reissued, or terminated for cause. The filing of a request by the Discharger for modification, revocation and reissuance, or termination, or a notification of planned changes or anticipated noncompliance does not stay any Order condition. [40 C.F.R. § 122.41(f)]

B. Duty to Reapply

If the Discharger wishes to continue an activity regulated by this Order after the expiration date of this Order, the Discharger must apply for and obtain a new permit. [40 C.F.R. § 122.41(b)]

C. Transfers

This Order is not transferable to any person except after notice to the Lahontan Water Board. The Lahontan Water Board may require modification or revocation and reissuance of the Order to change the name of the Discharger and incorporate such other requirements as may be necessary under the CWA and the Water Code. [40 C.F.R. §§ 122.41(l)(3), 122.61]

III. STANDARD PROVISIONS – MONITORING

- A.** Samples and measurements taken for the purpose of monitoring shall be representative of the monitored activity. [40 C.F.R. § 122.41(j)(1)]
- B.** Monitoring results must be conducted according to test procedures approved under 40 C.F.R. part 136 for the analyses of pollutants unless another method is required under 40 C.F.R. chapter 1, subchapters N or O. In the case of pollutants for which there are no approved methods under 40 C.F.R. part 136 or otherwise required under 40 C.F.R. subchapters N or O, monitoring must be conducted according to a test procedure specified in this Order for such pollutants. [40 C.F.R. §§ 122.41(j)(4), 122.44(i)(1)(iv)]

IV. STANDARD PROVISIONS – RECORDS

- A.** The Discharger shall retain records of all monitoring information, including all calibration and maintenance records and all original strip chart recordings for continuous monitoring instrumentation, copies of all reports required by this Order, and records of all data used to complete the application for this Order, for a period of at least three (3) years from the date of the sample, measurement, report or application. This period may be extended by request of the Lahontan Water Board Executive Officer at any time. [40 C.F.R. § 122.41(j)(2)]
- B.** Records of monitoring information shall include [40 C.F.R. § 122.41(j)(3)(i through vi)]:
 - 1. The date, exact place, and time of sampling or measurements;
 - 2. The individual(s) who performed the sampling or measurements;
 - 3. The date(s) analyses were performed;
 - 4. The individual(s) who performed the analyses;
 - 5. The analytical techniques or methods used; and
 - 6. The results of such analyses.
- C.** Claims of confidentiality for the following information will be denied [40 C.F.R. § 122.7(b)(1 and 2)]:
 - 1. The name and address of any permit applicant or Discharger; and
 - 2. Permit applications and attachments, permits and effluent data.

V. STANDARD PROVISIONS – REPORTING

A. Duty to Provide Information

The Discharger shall furnish to the Lahontan Water Board, State Water Board, or USEPA within a reasonable time, any information which the Lahontan Water Board, State Water Board, or USEPA may request to determine whether cause exists for modifying, revoking and reissuing, or terminating this Order or to determine compliance with this Order. Upon request, the Discharger shall also furnish to the Lahontan Water Board, State Water Board, or USEPA

copies of records required to be kept by this Order. [40 C.F.R. § 122.41(h); Water Code sections 13267 and 13383]

B. Signatory and Certification Requirements

1. All applications, reports, or information submitted to the Lahontan Water Board, State Water Board, and/or USEPA shall be signed and certified in accordance with Standard Provisions – Reporting sections V.B.2, V.B.3, V.B.4, and V.B.5 below. [40 C.F.R. § 122.41(k)]
2. All permit applications shall be signed by either a principal executive officer or ranking elected official. For purposes of this provision, a principal executive officer of a federal agency includes: (i) the chief executive officer of the agency, or (ii) a senior executive officer having responsibility for the overall operations of a principal geographic unit of the agency (e.g., Regional Administrators of USEPA). [40 C.F.R. § 122.22(a)(3)]
3. All reports required by this Order and other information requested by the Lahontan Water Board, State Water Board, or USEPA shall be signed by a person described in Standard Provisions – Reporting section V.B.2 above, or by a duly authorized representative of that person. A person is a duly authorized representative only if:
 - a. The authorization is made in writing by a person described in Standard Provisions – Reporting section V.B.2 above [40 C.F.R. § 122.22(b)(1)];
 - b. The authorization specifies either an individual or a position having responsibility for the overall operation of the regulated facility or activity such as the position of plant manager, operator of a well or a well field, superintendent, position of equivalent responsibility, or an individual or position having overall responsibility for environmental matters for the company. (A duly authorized representative may thus be either a named individual or any individual occupying a named position.) [40 C.F.R. § 122.22(b)(2)]; and
 - c. The written authorization is submitted to the Lahontan Water Board and State Water Board. [40 C.F.R. § 122.22(b)(3)]
4. If an authorization under Standard Provisions – Reporting V.B.3 above is no longer accurate because a different individual or position has responsibility for the overall operation of the facility, a new authorization satisfying the requirements of Standard Provisions – Reporting section V.B.3 above must be submitted to the Lahontan Water Board and State Water Board prior to or together with any reports, information, or applications, to be signed by an authorized representative. [40 C.F.R. § 122.22(c)]
5. Any person signing a document under Standard Provisions – Reporting sections V.B.2 or V.B.3 above shall make the following certification:

“I certify under penalty of law that this document and all attachments were prepared under my direction or supervision in accordance with a system designed to assure that qualified personnel properly gather and evaluate the information submitted. Based on my inquiry of the person or persons who manage the system or those persons directly responsible for gathering the information, the information submitted is, to the best of my knowledge and belief, true, accurate, and complete. I am aware that there are significant penalties for submitting false information, including the possibility of fine and imprisonment for knowing violations.” [40 C.F.R. § 122.22(d)]
6. Any person providing the electronic signature for documents described in Standard Provisions – Reporting sections V.B.1, V.B.2, or V.B.3 that are submitted electronically shall meet all relevant requirements of Standard Provisions – Reporting section V.B, and

shall ensure that all relevant requirements of 40 C.F.R. part 3 (Cross-Media Electronic Reporting) and 40 C.F.R. part 127 (NPDES Electronic Reporting Requirements) are met for that submission. [40 C.F.R. § 122.22(e)]

C. Monitoring Reports

1. Monitoring results shall be reported at the intervals specified in the Monitoring and Reporting Program (Attachment E) to this Order. [40 C.F.R. § 122.41(l)(4)]
2. Monitoring results must be reported on a Discharge Monitoring Report (DMR) form or forms provided or specified by the Lahontan Water Board or State Water Board for reporting the results of monitoring, sludge use, or disposal practices. As of December 21, 2016, all reports and forms must be submitted electronically to the initial recipient defined in Standard Provisions – Reporting section V.J and comply with 40 C.F.R. part 3, 40 C.F.R. section 122.22, and 40 C.F.R. part 127. [40 C.F.R. § 122.41(l)(4)(i)]
3. If the Discharger monitors any pollutant more frequently than required by this Order using test procedures approved under 40 C.F.R. part 136, or another method required for an industry-specific waste stream under 40 C.F.R. chapter 1, subchapters N or O, the results of such monitoring shall be included in the calculation and reporting of the data submitted in the DMR or sludge reporting form specified by the Lahontan Water Board. [40 C.F.R. § 122.41(l)(4)(ii)]
4. Calculations for all limitations, which require averaging of measurements, shall utilize an arithmetic mean unless otherwise specified in this Order. [40 C.F.R. § 122.41(l)(4)(iii)]

D. Compliance Schedules

Reports of compliance or noncompliance with, or any progress reports on, interim and final requirements contained in any compliance schedule of this Order, shall be submitted no later than 14 days following each schedule date. [40 C.F.R. § 122.41(l)(5)]

E. Twenty-Four Hour Reporting

1. The Discharger shall report to the Lahontan Water Board any noncompliance which may endanger health or the environment. Information shall be provided to the Lahontan Water Board orally within 24 hours from the time the Discharger becomes aware of the circumstances. A report shall also be provided within five (5) days of the time the Discharger becomes aware of the circumstances. The report shall contain a description of the noncompliance and its cause; the period of noncompliance, including exact dates and times (if the noncompliance has not been corrected the anticipated time it is expected to continue shall be reported); and steps taken or planned to reduce, eliminate, and prevent reoccurrence of the noncompliance. [40 C.F.R. § 122.41(l)(6)(i)]

Noncompliance reports for events related to combined sewer overflows, sanitary overflows, or bypass must include the data described above (with the exception of time of discovery) as well as the type of event (i.e., combined sewer overflow, sanitary sewer overflow, or bypass event), type of overflow structure (e.g., manhole, combined sewer overflow outfall), discharge volume untreated by the treatment works treating domestic sewage, types of human health and environmental impacts of the event, and whether the noncompliance was related to wet weather.

As of December 21, 2020, all noncompliance reports related to combined sewer overflows, sanitary sewer overflows, or bypass events must be submitted electronically to the initial recipient defined in Standard Provisions – Reporting section V.J. The reports shall comply with 40 C.F.R. part 3, 40 C.F.R. section 122.22, and 40 C.F.R. part 127. The Lahontan Water Board may also require the Discharger to electronically submit

reports not related to combined sewer overflows, sanitary sewer overflows, or bypass events under this section. [40 C.F.R. § 122.41(l)(b)(i)]

2. The following information must be reported to the Lahontan Water Board within 24 hours:
 - a. Any unanticipated bypass that exceeds any effluent limitation in this Order. [40 C.F.R. § 122.41(l)(6)(ii)(A)]
 - b. Any upset that exceeds any effluent limitation in this Order. [40 C.F.R. § 122.41(l)(6)(ii)(B)]
3. The Lahontan Water Board may waive the above-required written report on a case-by-case basis if an oral report has been received within 24 hours. [40 C.F.R. § 122.41(l)(6)(iii)]

F. Planned Changes

The Discharger shall give notice to the Lahontan Water Board as soon as possible of any planned physical alterations or additions to the permitted Facility. Notice is required under this provision only when 40 C.F.R. § 122.41(l)(1)(i through iii):

1. the alteration or addition to a permitted facility may meet one of the criteria for determining whether a facility is a new source in section 122.29(b);
2. the alteration or addition could significantly change the nature or increase the quantity of pollutants discharged (this notification applies to pollutants that are subject neither to effluent limitations in this Order nor to notification requirements under section 122.42(a)(1) - see Additional Provisions—Notification Levels section VII.A.1); or
3. the alteration or addition results in a significant change in the Discharger's sludge use or disposal practices, and such alteration, addition, or change may justify the application of permit conditions that are different from or absent in the existing permit, including notification of additional use or disposal sites not reported during the permit application process or not reported pursuant to an approved land application plan.

G. Anticipated Noncompliance

The Discharger shall give advance notice to the Lahontan Water Board of any planned changes in the permitted facility or activity that may result in noncompliance with this Order's requirements. [40 C.F.R. § 122.41(l)(2)]

H. Other Noncompliance

The Discharger shall report all instances of noncompliance not reported under Standard Provisions – Reporting sections V.C, V.D, and V.E above at the time monitoring reports are submitted. The reports shall contain the information listed in Standard Provision – Reporting section V.E above. For noncompliance events related to combined sewer overflows, sanitary sewer overflows, or bypass events, these reports shall contain the information described in Standard Provision – Reporting section V.E and the applicable required data in appendix A to 40 C.F.R. part 127. The Lahontan Water Board may also require the Discharger to electronically submit reports not related to combined sewer overflows, sanitary sewer overflows, or bypass events under this section. [40 C.F.R. § 122.41(l)(7)]

I. Other Information

When the Discharger becomes aware that it failed to submit any relevant facts in a permit application, or submitted incorrect information in a permit application or in any report to the Lahontan Water Board, State Water Board, or USEPA, the Discharger shall promptly submit such facts or information. [40 C.F.R. § 122.41(l)(8)]

J. Initial Recipient for Electronic Reporting Data

The owner, operator, or the duly authorized representative is required to electronically submit NPDES information specified in appendix A to 40 C.F.R. part 127 to the initial recipient defined in 40 C.F.R. section 127.2(b). USEPA will identify and publish the list of initial recipients on its website and in the Federal Register, by state and by NPDES data group [see 40 C.F.R. section 127.2(c)]. US EPA will update and maintain this listing. [40 C.F.R. § 122.41(l)(9)]

VI. STANDARD PROVISIONS – ENFORCEMENT

- A.** The Lahontan Water Board is authorized to enforce the terms of this permit under several provisions of the Water Code, including, but not limited to, Water Code sections 13268, 13385, 13386, and 13387.

VII. ADDITIONAL PROVISIONS – NOTIFICATION LEVELS

A. Non-Municipal Facilities

Existing manufacturing, commercial, mining, and silvicultural Dischargers shall notify the Lahontan Water Board as soon as they know or have reason to believe:

1. That any activity has occurred or will occur that would result in the discharge, on a routine or frequent basis, of any toxic pollutant that is not limited in this Order, if that discharge will exceed the highest of the following "notification levels" [40 C.F.R. § 122.42(a)(1)(i through iv):
 - a. 100 micrograms per liter ($\mu\text{g/L}$);
 - b. 200 $\mu\text{g/L}$ for acrolein and acrylonitrile; 500 $\mu\text{g/L}$ for 2,4-dinitrophenol and 2-methyl-4,6-dinitrophenol; and 1 milligram per liter (mg/L) for antimony;
 - c. Five (5) times the maximum concentration value reported for that pollutant in the Report of Waste Discharge; or
 - d. The level established by the Lahontan Water Board in accordance with section 122.44(f).
2. That any activity has occurred or will occur that would result in the discharge, on a non-routine or infrequent basis, of any toxic pollutant that is not limited in this Order, if that discharge will exceed the highest of the following "notification levels" [40 C.F.R. § 122.42(a)(2)(i through iv):
 - a. 500 micrograms per liter ($\mu\text{g/L}$);
 - b. 1 milligram per liter (mg/L) for antimony;
 - c. Ten (10) times the maximum concentration value reported for that pollutant in the Report of Waste Discharge; or
 - d. The level established by the Lahontan Water Board in accordance with section 122.44(f).

ATTACHMENT E – MONITORING AND REPORTING PROGRAM

Contents

I.	General Monitoring Provisions	E-2
II.	Monitoring Locations	E-3
III.	Influent Monitoring Requirements.....	E-3
	A. Monitoring Location INF-001	E-3
IV.	Effluent Monitoring Requirements	E-4
	A. Monitoring Location EFF-001	E-4
	B. Monitoring Location EFF-002.....	E-5
	C. Monitoring Location EFF-003.....	E-5
V.	Whole Effluent Toxicity Testing Requirements – Not Applicable.....	E-5
VI.	Land Discharge Monitoring Requirements – Not Applicable.....	E-5
VII.	Recycling Monitoring Requirements – Not Applicable	E-5
VIII.	Receiving Water Monitoring Requirements – Not Applicable.....	E-5
IX.	Other Monitoring Requirements	E-6
	A. Quarterly Drug and Chemical Use Report.....	E-6
	B. Feeding and Production	E-7
	C. Priority Pollutant Metal Monitoring.....	E-7
	D. Annual Best Management Practices (BMP) Plan and Storm Water Pollution Prevention Plan (SWPPP) Reporting	E-7
	E. Visual Observations	E-8
X.	Reporting Requirements	E-8
	A. General Monitoring and Reporting Requirements	E-8
	B. Self-Monitoring Reports (SMRs)	E-8
	C. Discharge Monitoring Reports.....	E-10
	D. Other Reports – Not Applicable.....	E-12
	E. Summary of Reports	E-12

Tables

Table E-1.	Monitoring Station Locations	E-3
Table E-2.	Influent Monitoring – Monitoring Location INF-001.....	E-3
Table E-3.	Effluent Monitoring – Monitoring Location EFF-001	E-4
Table E-4.	Effluent Monitoring – Monitoring Location EFF-002	E-5
Table E-5.	Effluent Monitoring – Monitoring Location EFF-003	E-5
Table E-6.	Water Quality Objectives for Drugs and Chemicals Applied Directly to Water.....	E-7
Table E-7.	Monitoring Periods and Reporting Schedule.....	E-9
Table E-8.	Summary of Tables	E-12

ATTACHMENT E – MONITORING AND REPORTING PROGRAM (MRP)

The Code of Federal Regulations (40 C.F.R. § 122.48) requires that all NPDES permits specify monitoring and reporting requirements. Water Code sections 13267 and 13383 also authorize the Lahontan Water Board to require technical and monitoring reports. This MRP establishes monitoring and reporting requirements that implement federal and California regulations.

I. GENERAL MONITORING PROVISIONS

- A.** Samples and measurements taken as required herein shall be representative of the volume and nature of the monitored discharge. All samples shall be taken at the monitoring locations specified below and, unless otherwise specified, before the monitored flow joins or is diluted by any other waste stream, body of water, or substance. Monitoring locations shall not be changed without notification to and the approval from the Lahontan Water Board.
- B.** Appropriate flow measurement devices and methods consistent with accepted scientific practices shall be selected and used to ensure accuracy and reliability for measuring discharge volumes. The flow measurement devices shall be installed, calibrated, and maintained to ensure that the accuracy of the measurements is consistent with the accepted capability of that type of device. Devices selected shall be capable of measuring flows with a maximum deviation of less than ± 10 percent from true discharge rates throughout the range of expected discharge volumes.
- C.** Laboratories analyzing monitoring samples shall be certified by the State Water Resources Control Board, Division of Drinking Water in accordance with the provisions of Water Code section 13176, and the laboratories must include quality assurance/quality control data with their reports. In the event a certified laboratory is not available to the Discharger, analyses performed by a non-certified laboratory or using field test kits will be accepted provided that a Quality Assurance - Quality Control Program (QA/QC) is instituted by the laboratory and approved by the Executive Officer. Documentation of QA/QC protocols and adherence to the protocols must be kept in the laboratory or at the site for field test kits and shall be available for inspection by Lahontan Water Board staff. The QA/QC Program must conform to USEPA guidelines or to procedures approved by the Lahontan Water Board. Supplemental field testing for constituents that could be analyzed by a certified laboratory may be done in the field with test kits and meters provided:
 - 1.** Samples collected at the minimum-required monitoring frequencies are performed by a certified lab,
 - 2.** A QA/QC program approved by the Executive Officer is followed,
 - 3.** Detection limits, accuracy, and precision of the kits and meters meet USEPA and Surface Water Ambient Monitoring Program (SWAMP) standards, and
 - 4.** All results for field testing must be reported to the Lahontan Water Board in quarterly and annual self-monitoring reports (SMRs). Supporting QA/QC data must be determined using an established program and retained onsite and reported if requested
- D.** All monitoring instruments and devices used by the Discharger to fulfill the prescribed monitoring program shall be properly maintained and calibrated as necessary to ensure their continued accuracy. All flow measurement devices shall be calibrated at least once per year to ensure continued accuracy of the devices.
- E.** Monitoring results, including non-compliance, shall be reported at intervals and in a manner specified in this Monitoring and Reporting Program.

- F. The Discharger shall ensure that the results of the Discharge Monitoring Report-Quality Assurance (DMR-QA) Study or the most recent Water Pollution Performance Evaluation Study are submitted annually (by February 1 of each year) to the State Water Board at the following address:

State Water Resources Control Board
 Quality Assurance Program Officer
 Office of Information Management and Analysis
 1001 I Street, Sacramento, CA 95814

II. MONITORING LOCATIONS

The Discharger shall establish the following monitoring locations to demonstrate compliance with the effluent limitations, discharge specifications, and other requirements in this Order:

Table E-1. Monitoring Station Locations

Discharge Point Name	Monitoring Location Name	Monitoring Location Description
--	INF-001	At the head box of the production raceways, where a representative sample of influent water from the groundwater supply wells can be obtained prior to entering the fish rearing ponds or mixing with recirculation water.
001 and 002	EFF-001 ¹	From the final splitter box at the outfall from the settling pond.
002	EFF-002	In the surface water channel to the Spring Valley Lake Home Owners Association property, after the splitter box and before the channel terminates at Pond 1.
001	EFF-003	Effluent flow to the Mojave River and adjacent wetlands from Discharge Point 001 (calculated).

¹ Monitoring for total combined flow shall be measured at the outfall from the settling pond after the split to the second settling basin and prior to the final splitter box and sluice gate.

III. INFLUENT MONITORING REQUIREMENTS

A. Monitoring Location INF-001

1. The Discharger shall monitor the influent to the Facility at Monitoring Location INF-001 as follows:

Table E-2. Influent Monitoring – Monitoring Location INF-001

Parameter	Units	Sample Type	Minimum Sampling Frequency ¹	Required Analytical Test Method
Boron, Total Recoverable	mg/L	Grab	1/Year	2
Chloride	mg/L	Grab	1/Year	2
Electrical Conductivity @ 25°C	µmhos/cm	Grab	1/Month	2,3
Fluoride, Total	mg/L	Grab	1/Quarter	2
Nitrate Nitrogen, Total (as N)	mg/L	Grab	1/Year	2
Nitrogen, Total (as N)	mg/L	Grab	1/Year	2
pH	standard units	Grab	1/Month	2,3
Sulfate, Total (as SO ₄)	mg/L	Grab	1/Year	2
Temperature	°C	Grab	1/Month	2,3

Parameter	Units	Sample Type	Minimum Sampling Frequency ¹	Required Analytical Test Method
Total Dissolved Solids (TDS)	mg/L	Grab	1/Year	2

¹ Pollutants must be sampled concurrent with effluent samples.

² Pollutants shall be analyzed using the analytical methods described in 40 C.F.R. part 136. Where no methods are specified for a given pollutant, pollutants shall be analyzed by a method proposed by the Discharger and approved by the Executive Officer.

³ Field tests are authorized for the listed parameters because it is impractical to analyze these parameters in an ELAP certified lab. Standard quality control must be exercised regarding equipment calibration, etc.

IV. EFFLUENT MONITORING REQUIREMENTS

A. Monitoring Location EFF-001

- The Discharger shall monitor effluent from the Facility at Monitoring Location EFF-001 as follows:

Table E-3. Effluent Monitoring – Monitoring Location EFF-001

Parameter	Units	Sample Type	Minimum Sampling Frequency ¹	Required Analytical Test Method
Flow (Total Combined) ²	MGD	Meter	Continuous	--
Ammonia Nitrogen, Total (as N)	mg/L	Grab	1/Year	3
Boron, Total Recoverable	mg/L	Grab	1/Year	3
Chloramine-T	mg/L	Grab	1/Month During Use ⁴	3
Chloride	mg/L	Grab	1/Year ⁵	3
Dissolved Oxygen	mg/L	Grab	1/Quarter	3,9
Electrical Conductivity @ 25°C	µmhos/cm	Grab	1/Month ⁵	3,9
Fluoride, Total	mg/L	Grab	1/Quarter	3
Formaldehyde	mg/L	Grab	1/Month During Use ⁴	3
Hardness, Total (as CaCO ₃)	mg/L	Grab	1/Month	3
Hydrogen Peroxide	mg/L	Grab	1/Month During Use ⁴	3
Nitrate Nitrogen, Total (as N)	mg/L	Grab	1/Year	3
Nitrogen, Total (as N)	mg/L	Grab	1/Year	3
Manganese, Total Recoverable	µg/L	Grab	1/Quarter ⁶	3
pH	standard units	Grab	1/Month ^{7,8}	3,9
Potassium Permanganate	mg/L	Grab	1/Month During Use ⁴	3
PVP Iodine (iodophor)	mg/L	Grab	1/Month During Use ⁴	3
Settleable Solids	mL/L	Grab	1/Month ⁷	3
Sulfate, Total (as SO ₄)	mg/L	Grab	1/Year	3
Temperature	°C	Grab	1/Month	3,9
Total Dissolved Solids (TDS)	mg/L	Grab	1/Year ⁵	3
Total Suspended Solids (TSS)	mg/L	Grab	1/Month ⁷	3

Parameter	Units	Sample Type	Minimum Sampling Frequency ¹	Required Analytical Test Method
-----------	-------	-------------	---	---------------------------------

- ¹ Pollutants must be sampled concurrent with influent samples.
- ² Monitoring for total combined flow shall be measured at the outfall of the settling pond after the split to the second settling basin and prior to the final splitter box and sluice gate.
- ³ Pollutants shall be analyzed using the analytical methods described in 40 C.F.R. part 136. Where no methods are specified for a given pollutant, pollutants shall be analyzed by a method proposed by the Discharger and approved by the Executive Officer.
- ⁴ When this chemical is added to waters of the Facility, a sample of the effluent shall be collected at a time when the concentration of the parameter in the effluent is expected to be at a maximum. After the initial sample, if subsequent treatments use the same amount of chemical, and the flow rate and final concentration is calculated to be the same, the Discharger may submit a calculated final effluent concentration upon approval by the Executive Officer.
- ⁵ If sodium chloride is used in a given monitoring period, monitoring shall be collected at a time when the concentration of the parameter in the effluent is expected to be at a maximum.
- ⁶ If potassium permanganate is used in a given quarter, monitoring for manganese shall be conducted concurrent with monitoring for potassium permanganate.
- ⁷ Monitoring shall be conducted during cleaning operations or other operational modes that provide the worst-case for affecting the parameter in the effluent.
- ⁸ If acetic acid, carbon dioxide, or sodium bicarbonate is used in a given monitoring period, monitoring for pH shall be collected at a time when the pH of the effluent is expected to be at a maximum.
- ⁹ Field tests are authorized for the listed parameters because it is impractical to analyze these parameters in an ELAP certified lab. Standard quality control must be exercised regarding equipment calibration, etc.

B. Monitoring Location EFF-002

1. The Discharger shall monitor effluent from the Facility at Monitoring Location EFF-002 as follows:

Table E-4. Effluent Monitoring – Monitoring Location EFF-002

Parameter	Units	Sample Type	Minimum Sampling Frequency	Required Analytical Test Method
Flow	MGD	Meter	1/Month ¹	--

- ¹ The volume of wastewater discharged shall be recorded monthly. For each discharge period, the Discharger shall calculate and report the total volume of wastewater discharged and the average flow rate in gallons per day.

C. Monitoring Location EFF-003

1. The Discharger shall monitor effluent from the Facility at Monitoring Location EFF-003 as follows:

Table E-5. Effluent Monitoring – Monitoring Location EFF-003

Parameter	Units	Sample Type	Minimum Sampling Frequency	Required Analytical Test Method
Flow	MGD	Calculate ¹	1/Month ²	--

- ¹ Flow at Monitoring Location EFF-003 shall be calculated by subtracting the flow measured at Monitoring Location EFF-002 from the total combined flow measured at Monitoring Location EFF-001.
- ² The volume of wastewater discharged shall be recorded monthly. For each discharge period, the Discharger shall calculate and report the total volume of wastewater discharged and the average flow rate in gallons per day.

V. WHOLE EFFLUENT TOXICITY TESTING REQUIREMENTS – NOT APPLICABLE

VI. LAND DISCHARGE MONITORING REQUIREMENTS – NOT APPLICABLE

VII. RECYCLING MONITORING REQUIREMENTS – NOT APPLICABLE

VIII. RECEIVING WATER MONITORING REQUIREMENTS – NOT APPLICABLE

IX. OTHER MONITORING REQUIREMENTS

A. Quarterly Drug and Chemical Use Report

The information listed below shall be submitted for all aquaculture drugs or chemicals used at the Facility, including those administered by injection or in medicated feed. This information shall be reported at quarterly intervals and submitted with the quarterly SMRs using the drug and chemical usage report table found in Attachment H of this Order.

1. The name(s) and active ingredient(s) of the drug or chemical.
2. The date(s) of application.
3. The purpose(s) for the application.
4. The method of application (e.g., immersion bath, flush, administered in feed, injection), duration of treatment, whether the treatment was static or flush (for drugs or chemicals applied directly to water), amount in gallons or pounds used, treatment concentration(s), treatment unit, pond or raceway where application was made, and the flow measured in million gallons per day (MGD) in the treatment units.
5. The total flow through the Facility measured in MGD to the discharge point after mixing with the treated water.
6. The method of disposal for drugs or chemicals used but not discharged in the effluent.
7. For drugs and chemicals applied directly to water (i.e., immersion bath, "drip" treatment, flush treatment), the estimated concentration in the effluent at the point of discharge. The specific authorized drugs and chemicals that are applied directly to water include the following: acetic acid, carbon dioxide, Chloramine-T, formalin, hydrogen peroxide, MS-222, oxytetracycline hydrochloride (when used as bath treatment), penicillin G, potassium permanganate, PVP Iodine, sodium bicarbonate, and sodium chloride. Reporting of the estimated effluent concentration is required whenever the drug or chemical is used, even if an effluent sample has been collected. Reporting of the estimated effluent concentration is not required for drugs and chemicals administered by injection or in medicated feed.

The Discharger shall use the following formula to calculate concentration (C) at the point of discharge.

C = concentration of chemical or drug at the point of discharge

$C = (\text{treatment concentration}) \times (\text{flow in treatment area}) + (\text{flow at point of discharge})$

Example: Potassium permanganate (KMNO₄) concentration

$C = 2.0 \text{ mg/L (KMNO}_4) \times \underline{0.45 \text{ MGD (flow through treatment area)}}$

$5.0 \text{ MGD (flow at point of discharge)}$

$C = 2.0 \text{ mg/L} \times 0.09 = 0.18 \text{ mg/L potassium permanganate at the point of discharge.}$

This information shall be submitted quarterly. If the analysis of this chemical use compared with any toxicity testing results or other available information for the therapeutic agent, chemical or anesthetic indicates that the discharge may cause, have the reasonable potential to cause, or contribute to an excursion of a numeric or narrative water quality criterion or objective, the Executive Officer may require site-specific whole effluent toxicity (WET) tests using *Ceriodaphnia dubia*.

8. Of the list of approved drugs and chemicals provided in Attachment G to this Order, submit an affirmative list of those specific drugs and chemicals that were not used during

the reporting quarter using the Drug and Chemical Non Use Table provided in Attachment H to this Order.

9. For the drugs and chemicals for which the estimated concentrations are reported in section IX.A.7 above, the most stringent water quality objective for each respective drug or chemical applied, selected from the table below:

Table E-6. Water Quality Objectives for Drugs and Chemicals Applied Directly to Water

Drug or Chemical	Water Quality Objective	Basis
Acetic Acid	Not Available	Not Available
Carbon Dioxide	Not Available	Not Available
Chloramine-T	86.3 mg/L	96-hour NOEC for <i>C. dubia</i>
Formalin	1.3 mg/L	96-hour NOAEL for <i>C. dubia</i>
Hydrogen Peroxide	1.3 mg/L	96-hour NOAEL for <i>C. dubia</i>
MS-222	70 mg/L	96-hour NOEC for <i>C. dubia</i>
Oxytetracycline Hydrochloride	40.4 mg/L	96-hour NOAEL for <i>C. dubia</i>
Penicillin G	350 mg/L	7-day NOEC for <i>P. promelas</i>
Potassium Permanganate	0.038 mg/L	96-hour NOAEL for <i>C. dubia</i>
PVP Iodine	0.86 mg/L	96-hour NOAEL for <i>C. dubia</i>
Sodium Bicarbonate	Not Available	Not Available
Sodium Chloride	Not Available	Not Available

B. Feeding and Production

The Discharger shall develop an annual report describing the feeding and production for the Facility for the previous calendar year. The annual report shall be submitted by February 1 of each year and include the following information:

1. monthly food usage in pounds for each calendar month, and
2. annual production of aquatic animals in pounds per year.

C. Priority Pollutant Metal Monitoring

Potential discharge of priority pollutants is based on the probability of the pollutants being present in the groundwater pumped from source wells and from data collected from other concentrated aquatic animal production (CAAP) facilities. Data compiled from CAAP facilities, local drinking water wells, and the State Water Board’s Groundwater Ambient Monitoring Association (GAMA) database were used to determine the potential for metals and other priority pollutants to occur. Accordingly, the Lahontan Water Board requires sampling and analysis of the influent and effluent for the priority pollutant metals listed in Attachment J at least once per permit cycle. The samples shall be analyzed for priority pollutant metals in the **year 2020** and reported to the Lahontan Water Board **no later than February 1, 2021** in the SMR, and included in the Report of Waste Discharge. (Refer to Attachment J for the specific monitoring requirements.)

D. Annual Best Management Practices (BMP) Plan and Storm Water Pollution Prevention Plan (SWPPP) Reporting

The Discharger must annually (February 1) certify that the BMP Plan for Aquaculture Operations and the Facility SWPPP meet the requirements of this Order and are being implemented as written. If changes are necessary to accurately reflect operations, maintenance, and the management and control of pollutants at the Facility, a revised plan shall be submitted to the Lahontan Water Board along with the above certification. The annual

report must include a specific section providing this analysis and a summary of changes, if any.

E. Visual Observations

1. Within two business days (48 hours) after each qualifying rain event the Discharger shall observe and record the presence or absence of floating and suspended materials, a sheen on the surface, discolorations, turbidity, odors, and source(s) of any observed pollutants. These observations shall be made at the property line where the channel terminates near the Golf Course Pond 1, after storm water coningles with effluent flows. Visual observations shall be submitted in the next quarterly SMR after the observations and summarized in the annual report.
2. Quarterly visual inspections of the Facility shall be made to identify any non-storm water discharge and its sources to ensure that BMPs are being implemented and are effective. Any non-storm water discharges observed and their sources are reported and described in the next quarterly report following the discharge and are summarized in the annual report.

X. REPORTING REQUIREMENTS

A. General Monitoring and Reporting Requirements

1. The Discharger shall comply with all Standard Provisions (Attachment D) related to monitoring, reporting, and recordkeeping.
2. The Discharger shall submit a summary annual monitoring report. The report shall contain all data collected for the year in a table, and both tabular and graphical summaries of the monitoring data obtained during the previous year(s).
3. The Discharger shall report to the Lahontan Water Board any toxic chemical release data it reports to the State Emergency Response Commission within 15 days of reporting the data to the Commission pursuant to section 313 of the "*Emergency Planning and Community Right to Know Act*" of 1986.
4. The Discharger shall calculate and report the result of compliance with average monthly effluent limitations, as necessary. Additional samples may be collected to demonstrate compliance.
5. For each parameter with an effluent limitation listed in section IV of this Order, the Discharger shall determine and report compliance with respect to the effluent limitation.
6. As part of the Report of Waste Discharge submitted in accordance with Table 3 on the cover page of this Order, the Discharger shall provide all reported data in an Excel tabular format that can be used to evaluate compliance with interim and/or final effluent limitations and conduct a reasonable potential analysis. Electronic submittal of data is required to CIWQS. If the State Board's Permit Entry Tool does not allow data to be submitted, it must be provided separately.

B. Self-Monitoring Reports (SMRs)

1. The Discharger shall electronically submit SMRs using the State Water Board's California Integrated Water Quality System (CIWQS) Program Web site (<http://www.waterboards.ca.gov/ciwqs/index.html>). The CIWQS Web site will provide additional information for SMR submittal in the event there will be a planned service interruption for electronic submittal.
2. The Discharger shall report in the SMR the results for all monitoring specified in this MRP under sections III through IX. The Discharger shall submit quarterly SMRs including

the results of all required monitoring using USEPA-approved test methods or other test methods specified in this Order. SMRs are to include all new monitoring results obtained since the last SMR was submitted. If the Discharger monitors any pollutant more frequently than required by this Order, the results of this monitoring shall be included in the calculations and reporting of the data submitted in the SMR.

3. Monitoring periods and reporting for all required monitoring shall be completed according to the following schedule:

Table E-7. Monitoring Periods and Reporting Schedule

Sampling Frequency	Monitoring Period Begins On...	Monitoring Period	SMR Due Date
Continuous	Permit effective date	All	May 1 August 1 November 1 February 1 of following year
1/Month	Permit effective date	1 st day of calendar month through last day of calendar month	May 1 August 1 November 1 February 1 of following year
1/Quarter	Permit effective date	January 1 through March 31 April 1 through June 30 July 1 through September 30 October 1 through December 31	May 1 August 1 November 1 February 1 of following year
1/Year	Permit effective date	January 1 through December 31	February 1 of following year
1/Permit Cycle	Permit effective date	In the year 2019	February 1, 2020

4. **Reporting Protocols.** The Discharger shall report with each sample result the applicable Reporting Level (RL) and the current Method Detection Limit (MDL), as determined by the procedure in 40 C.F.R. part 136.

The Discharger shall report the results of analytical determinations for the presence of chemical constituents in a sample using the following reporting protocols:

- a. Sample results greater than or equal to the RL shall be reported as measured by the laboratory (i.e., the measured chemical concentration in the sample).
- b. Sample results less than the RL, but greater than or equal to the laboratory’s MDL, shall be reported as “Detected, but Not Quantified,” or DNQ. The estimated chemical concentration of the sample shall also be reported.

For the purposes of data collection, the laboratory shall write the estimated chemical concentration next to DNQ. The laboratory may, if such information is available, include numerical estimates of the data quality for the reported result. Numerical estimates of data quality may be percent accuracy (\pm a percentage of the reported value), numerical ranges (low to high), or any other means considered appropriate by the laboratory.

- c. Sample results less than the laboratory’s MDL shall be reported as “Not Detected,” or ND.

- d. Dischargers are to instruct laboratories to establish calibration standards so that the ML value (or its equivalent if there is differential treatment of samples relative to calibration standards) is the lowest calibration standard. At no time is the Discharger to use analytical data derived from extrapolation beyond the lowest point of the calibration curve.
 - e. Sample collection date and time, sample analysis date and time, the name of individual(s) who collected the sample, the name of individual(s) who analyzed the sample, sample collection method(s) as listed in 40 C.F.R. part 136, sample analysis method(s) as listed in 40 C.F.R. part 136, sample preservation method(s) used between sample collection and analysis, and applicable QA/QC (Quality Assurance/Quality Control) data will be included with reported analytical results.
5. **Compliance Determination.** Compliance with effluent limitations shall be determined using sample reporting protocols defined above and Attachment A. For purposes of reporting and administrative enforcement by the Lahontan Water Board and State Water Board, the Discharger shall be deemed out of compliance with effluent limitations if the concentration of the pollutant in the monitoring sample is greater than the effluent limitation established in this Order and greater than or equal to the reporting level (RL).
6. **Multiple Sample Data.** When determining compliance with an AMEL or MDEL and more than one sample result is available, the Discharger shall compute the arithmetic mean unless the data set contains one or more reported determinations of "Detected, but Not Quantified" (DNQ) or "Not Detected" (ND). In those cases, the Discharger shall compute the median in place of the arithmetic mean in accordance with the following procedure:
 - a. The data set shall be ranked from low to high, ranking the reported ND determinations lowest, DNQ determinations next, followed by quantified values (if any). The order of the individual ND or DNQ determinations is unimportant.
 - b. The median value of the data set shall be determined. If the data set has an odd number of data points, then the median is the middle value. If the data set has an even number of data points, then the median is the average of the two values around the middle unless one or both of the points are ND or DNQ, in which case the median value shall be the lower of the two data points where DNQ is lower than a value and ND is lower than DNQ.
7. The Discharger shall submit SMRs in accordance with the following requirements:
 - a. The Discharger shall arrange all reported data in a tabular format. The data shall be summarized to clearly illustrate whether the facility is operating in compliance with interim and/or final effluent limitations. The Discharger is not required to duplicate the submittal of data that is entered in a tabular format within CIWQS. When electronic submittal of data is required and CIWQS does not provide for entry into a tabular format within the system, the Discharger shall electronically submit the data in a tabular format as an attachment.
 - b. The Discharger shall attach a cover letter to the SMR. The information contained in the cover letter shall clearly identify violations of the waste discharge requirements; discuss corrective actions taken or planned; and the proposed time schedule for corrective actions. Identified violations must include a description of the requirement that was violated and a description of the violation.

C. eDischarge Monitoring Reports

1. DMRs are USEPA reporting requirements. The Discharger shall electronically certify and submit DMRs together with SMRs using Electronic Self-Monitoring Reports module

eSMR 2.5 or any upgraded version. Electronic DMR submittal shall be in addition to electronic SMR submittal. Information about electronic DMR submittal is available at the DMR website at:
<http://www.waterboards.ca.gov/water_issues/programs/discharge_monitoring>

TENTATIVE

D. Other Reports – Not Applicable

E. Summary of Reports

Table E-8 summarizes all reports the Discharger is required to submit.

Table E-8. Summary of SMRs.

Report Name	Monitoring Period	Due Date
Quarterly Influent, Effluent, and Flow Monitoring Report	January 1 through March 31 April 1 through June 30 July 1 through September 30 October 1 through December 31	May 1 August 1 November 1 February 1 of following year
Annual Influent and Effluent Monitoring Report	January 1 through December 31	February 1 of following year
Quarterly Drug and Chemical Use Report	January 1 through March 31 April 1 through June 30 July 1 through September 30 October 1 through December 31	May 1 August 1 November 1 February 1 of following year
Feeding and Production	January 1 through December 31	February 1 of following year
BMP Plan Update Certification	N/A, one time report	October 1, 2017
BMP Plan Annual Re-Certification (include Amended Plan as appropriate)	January 1 through December 31	February 1 of each year
SWPPP Annual Comprehensive Site Compliance Evaluation Report	January 1 through December 31	February 1 of each year
Discharge Monitoring Report Quality Assurance Study	N/A	February 1 of each year
Priority Pollutant Metal Monitoring Report	January 1, 2020 through December 31, 2020	February 1, 2021
Report of Waste Discharge	N/A	December 29, 2021

ATTACHMENT F – FACT SHEET

Contents

I.	Permit Information.....	F-3
II.	Facility Description.....	F-4
	A. Description of Wastewater Treatment and Controls	F-5
	B. Discharge Points and Receiving Waters	F-6
	C. Summary of Existing Requirements and Self-Monitoring Report (SMR) Data	F-6
	D. Compliance Summary.....	F-7
	E. Planned Changes	F-8
III.	Applicable Plans, Policies, and Regulations	F-8
	A. Legal Authorities	F-8
	B. California Environmental Quality Act (CEQA).....	F-9
	C. State and Federal Laws, Regulations, Policies, and Plans	F-9
	D. Impaired Water Bodies on the CWA Section 303(d) List	F-13
	E. Other Plans, Policies and Regulations – Not Applicable	F-14
IV.	Rationale For Effluent Limitations and Discharge Specifications	F-14
	A. Discharge Prohibitions	F-14
	B. Technology-Based Effluent Limitations	F-14
	1. Scope and Authority	F-14
	2. Applicable Technology-Based Effluent Limitations.....	F-16
	C. Water Quality-Based Effluent Limitations (WQBELs)	F-17
	1. Scope and Authority	F-17
	2. Applicable Beneficial Uses and Water Quality Criteria and Objectives.....	F-18
	3. Determining the Need for WQBELs	F-19
	4. WQBEL Calculations	F-36
	5. Whole Effluent Toxicity (WET)	F-43
	D. Final Effluent Limitation Considerations	F-44
	1. Mass-based Effluent Limitations	F-44
	2. Anti-Backsliding Requirements	F-44
	3. Antidegradation Policies	F-45
	4. Stringency of Requirements for Individual Pollutants	F-45
	E. Interim Effluent Limitations – Not Applicable	F-45
	F. Land Discharge Specifications – Not Applicable	F-45
	G. Recycling Specifications – Not Applicable.....	F-46
V.	Rationale for Receiving Water Limitations	F-46
	A. Surface Water.....	F-46
	B. Groundwater.....	F-47
VI.	Rationale for Provisions	F-47
	A. Standard Provisions.....	F-47
	B. Special Provisions.....	F-47
	1. Reopener Provisions	F-47
	2. Special Studies and Additional Monitoring Requirements	F-47
	3. Best Management Practices and Pollution Prevention.....	F-48
	4. Construction, Operation, and Maintenance Specifications	F-48
	5. Special Provisions for Municipal Facilities (POTWs Only) – Not Applicable	F-48
	6. Other Special Provisions – Not Applicable.....	F-48
	7. Compliance Schedules – Not Applicable	F-48
VII.	Rationale for Monitoring and Reporting Requirements	F-49

- A. Influent Monitoring F-49
- B. Effluent Monitoring F-49
- C. Whole Effluent Toxicity Testing Requirements – Not Applicable F-50
- D. Receiving Water Monitoring F-50
 - 1. Surface Water – Not Applicable F-50
 - 2. Groundwater – Not Applicable F-51
- E. Other Monitoring Requirements F-51
- VIII. Public Participation..... F-52
 - A. Notification of Interested Parties F-52
 - B. Written Comments F-52
 - C. Public Hearing Opportunity F-52
 - D. Reconsideration of Waste Discharge Requirements F-52
 - E. Information and Copying F-53
 - F. Register of Interested Persons..... F-53
 - G. Additional Information F-53

Tables

- Table F-1. Facility Information..... F-3
- Table F-2. Historic Effluent Limitations and Monitoring Data – Discharge Points 001 and 002..... F-7
- Table F-3. Compliance Summary – Discharge Points 001 and 002 F-7
- Table F-4. Surface Water Basin Plan Beneficial Uses F-9
- Table F-5. Ground Water Basin Plan Beneficial Uses F-9
- Table F-6. Summary of Technology-Based Effluent Limitations F-17
- Table F-7. Basin Plan Water Quality Objectives for the Mojave River (at Victorville)..... F-19
- Table F-8. Basin Plan Water Quality Objectives for the West Fork Mojave River (at Lower Narrows)F-19
- Table F-9. Reasonable Potential Analysis Summary for Discharge Point 001..... F-21
- Table F-10. Summary of Reasonable Potential Analysis for Basin Plan Table
 3-20 and 3-21 Parameters F-24
- Table F-11. Aquatic Toxicity of Formalin¹ F-32
- Table F-12. Short-Term Aquatic Toxicity of Formalin¹ F-32
- Table F-13. Estimated Effluent Hydrogen Peroxide Concentrations..... F-34
- Table F-14. Summary of Fluoride Monitoring Data..... F-39
- Table F-15. Influent and Effluent Fluoride Monitoring Data F-40
- Table F-16. Summary of Water Quality-Based Effluent Limitations F-45
- Table F-17. Monitoring Location Nomenclature F-50

ATTACHMENT F – FACT SHEET

As described in section II.B of this Order, the Lahontan Water Board incorporates this Fact Sheet as findings of the Lahontan Water Board supporting the issuance of this Order. This Fact Sheet includes the legal requirements and technical rationale that serve as the basis for the requirements of this Order.

This Order has been prepared under a standardized format to accommodate a broad range of discharge requirements for dischargers in California. Only those sections or subsections of this Order that are specifically identified as “not applicable” have been determined not to apply to this Discharger. Sections or subsections of this Order not specifically identified as “not applicable” are fully applicable to this Discharger.

I. PERMIT INFORMATION

The following table summarizes administrative information related to the facility.

Table F-1. Facility Information

WDID	6B360812001
Discharger	California Department of Fish and Wildlife
Name of Facility	Mojave River Fish Hatchery
Facility Address	12550 Jacaranda Avenue
	Victorville, California, 92395
	San Bernardino County
Facility Contact, Title and Phone	Gary Williams, Senior Hatchery Supervisor, (760) 241-8472
Authorized Person to Sign and Submit Reports	Gary Williams, Senior Hatchery Supervisor, (760) 241-8472
Mailing Address	Same as Facility Address
Billing Address	Same as Facility Address
Type of Facility	Concentrated Aquatic Animal Production/Fish Hatchery (Standard Industrial Classification Code 0921)
Major or Minor Facility	Minor
Threat to Water Quality	2
Complexity	C
Pretreatment Program	N/A
Recycling Requirements	N/A
Facility Permitted Flow	Not Applicable
Facility Design Flow	8.9 million gallons per day (MGD)
Watershed	Upper Mojave Hydrologic Area
Receiving Water	Mojave River, minor surface waters tributary to the Mojave River, and groundwater
Receiving Water Type	Inland surface water

- A. California Department of Fish and Wildlife (hereinafter Discharger) is the owner and operator of the Mojave River Fish Hatchery (hereinafter Facility), a cold water concentrated aquatic animal production (CAAP) facility.

For the purposes of this Order, references to the “discharger” or “permittee” in applicable federal and state laws, regulations, plans, or policy are held to be equivalent to references to the Discharger herein.

- B. The Facility discharges wastewater to the Mojave River and minor surface waters that are tributary to the Mojave River, waters of the United States, within the Upper Mojave Hydrologic Area of the Mojave Hydrologic Unit (CA Department of Water Resources No. 628.20). The Facility is currently regulated by Order No. R6V-2011-0081 and National Pollutant Discharge Elimination System (NPDES) Permit No. CA0102814 adopted on October 12, 2011 and expires on October 12, 2016. Attachment B provides a map of the area around the Facility. Attachment C provides a flow schematic of the Facility.
- C. When applicable, state law requires dischargers to file a petition with the State Water Board, Division of Water Rights and receive approval for any change in the point of discharge, place of use, or purpose of use of treated wastewater that decreases the flow in any portion of a watercourse. The State Water Board retains separate jurisdictional authority to enforce any applicable requirements under Water Code section 1211. This is not an NPDES permit requirement.
- D. The Discharger filed a report of waste discharge (ROWD) and submitted an application for reissuance of its Waste Discharge Requirements (WDRs) and NPDES permit on April 8, 2016. Supplemental information was provided on June 17, 2016. The application was deemed complete on June 17, 2016.
- E. Regulations at 40 C.F.R. section 122.46 limit the duration of NPDES permits to a fixed term not to exceed 5 years. Accordingly, Table 3 of this Order limits the duration of the discharge authorization. However, pursuant to California Code of Regulations, title 23, section 2235.4, the terms and conditions of an expired permit are automatically continued pending reissuance of the permit if the Discharger complies with all federal NPDES requirements for continuation of expired permits.

II. FACILITY DESCRIPTION

The Discharger owns and operates a cold water CAAP facility. The Facility has the capacity to produce between 450,000 and 675,000 pounds (lbs) of rainbow trout and between 15,000 and 22,000 lbs of brown trout. According to the ROWD, the Facility currently produces between 400,000 and 500,000 lbs of rainbow trout annually. According to the ROWD, 34,000 lbs of food are currently being fed during the month of maximum feeding (i.e., June).

The Facility includes six groundwater wells, three aeration towers, six production raceways (A through F), a hatchery building, two recirculating aquaculture systems, and a settling pond.

Six groundwater wells provide water for the Facility, with two to four wells used at a time. Currently, two wells are inactive and unusable. Groundwater is pumped to an aeration tower to increase dissolved oxygen and is then supplied to the production raceways and hatchery building when in operation.

The six production raceways are 1,000 feet long, and each raceway is divided into ten 100-foot long ponds separated by baffles. Fresh groundwater is supplied to Raceways A and B, where younger fish are held. A mix of fresh groundwater and recirculated water is supplied to Raceways C through F (see below for a description of the recirculation water). Water from the first 500 feet of the raceways is diverted to a mid-pond aeration tower, where it is aerated a second time, and then redistributed to the lower 500 feet of the raceways. Wastewater from the production raceways flows to the settling pond.

Aerated groundwater is pumped to the hatchery building, where it is used for egg incubation and hatching in jars and troughs. Hatchery operations typically occur between January and February. Wastewater from the hatchery building is collected in a floor drain that discharges to a pipe beneath the raceways. The pipe directs hatchery building wastewater to a sump where it is then conveyed to the settling pond through an aboveground pipe.

In 2014, the Discharger installed two self-contained recirculating aquaculture systems to provide temporary refuge for various fish species in peril from drought until conditions are deemed adequate for their release. Each recirculating aquaculture system consists of three 500-gallon tanks, recirculation pumps, high-powered ultraviolet light (UV) disinfection, biofiltration for neutralizing nitrogenous waste, and a water chiller to provide optimal conditions. These systems operate using 80 to 100 percent recirculated water with an estimated flow-through of five (5) gallons per minute (gpm). The sand filters are backwashed two to three times per week, using a total of 60 to 100 gallons of water per flush. The effluent discharge from the systems, including filter backwash, are discharged to the settling pond.

Wastewater from the production raceways, hatchery building, and recirculating aquaculture systems is discharged to the settling pond. The settling pond is divided into two basins by a berm that runs through the center of the pond. Each settling basin is triangle-shaped, with a surface area of 18,200 square feet and a depth that tapers from 12 feet to 16 feet. Wastewater enters the first settling basin on the western side and exits to a "Y" splitter box on the opposite side. From the "Y" splitter box, a portion of the wastewater from the first settling basin is directed to the second settling basin (approximately 1.9 MGD) and the remainder flows through a flow meter and into another splitter box that separates the effluent into two discharges. Wastewater from the second settling basin is pumped to a third aeration tower and is then comingled with fresh groundwater at the head boxes of raceways C through F, where it receives UV disinfection. Valves at the head boxes allow staff to control the ratio of fresh groundwater to recirculation water. Approximately once per permit term, the Discharger must take the aeration tower offline for inspection and maintenance. To complete the inspection, approximately 1,000 gallons is drained through a culvert under the hatchery residence road to a drainage channel where the water percolates within 100 feet.

Current discharges from the Facility include unused food, fish excrement, and fish health additives to food and water. The Discharger currently uses or has previously used during the term of Order No. R6V-2011-0081 the following drugs and chemicals in the raceways: sodium chloride (salt) as a flush treatment in the raceways and as a fish-cleansing agent to control the spread of fish disease; potassium permanganate to control gill bacteria on fish; hydrogen peroxide to control external parasites; and florfenicol; and oxytetracycline dihydrate as medicated feeds. Aquaculture drugs and chemicals that may be used at the Facility to treat various fish disease and parasitic outbreaks include acetic acid, amoxicillin trihydrate, carbon dioxide, Chloramine-T, Chorulon®, Epson salt, erythromycin, florfenicol, formalin, hydrogen peroxide, Ivermectin, MS-222, Ovaplant®, oxytetracycline hydrochloride, oxytetracycline dihydrate, penicillin G, potassium permanganate, PVP Iodine, SLICE, sodium bicarbonate, sodium chloride, Romet-30, vibrio vaccine (fish are removed via a basket, dipped in vaccine, and then returned to the raceway), and enteric redmouth bacterin (fish are removed via a basket, dipped in vaccine, and then returned to the raceway). These aquaculture drugs and chemicals, prescribed by the Discharger's Fish Health Laboratory, are to be used on an "as needed" basis to treat various fish disease and parasitic outbreaks. See Attachment G for additional information regarding aquaculture drugs and chemical use.

On January 11, 2010, the Discharger certified that *"the use of copper sulfate products has been discontinued at all DFG hatcheries."* Additionally, copper plates are not used on the dam boards at this Facility.

A. Description of Wastewater Treatment and Controls

Wastewater from the production raceways, hatchery building, and recirculating aquaculture systems is discharged to the flow-through settling pond, where solids are settled out prior to discharge.

B. Discharge Points and Receiving Waters

Wastewater diverted from the first settling basin in the “Y” splitter box flows to another splitter box and sluice gate valve system that directs effluent to either the Mojave River at Discharge Point 001 or to a pond (Pond 1) on the Spring Valley Lake Golf Course, owned by the Spring Valley Lake Home Owner's Association, at Discharge Point 002. Effluent from Discharge Point 002 ultimately reaches the Mojave River as overflow from Spring Valley Lake to the Mojave River and overflow from Horseshoe Lake to the Mojave River at the Lower Narrows after passing through Mojave Narrows Regional Park.

Receiving waters affected by effluent include channels that connect a series of minor surface waters, wetlands, and perennial flows in the Mojave River at the Lower Narrows; subsurface flows in the riparian aquifer under the dry Mojave River bed upstream of the Lower Narrows; and seasonal flows in the Mojave River upstream of the Lower Narrows.

The Mojave River is located within the Upper Mojave Hydrologic Area (Hydrologic Unit No. 628.20) of the Mojave Hydrologic Unit, and the groundwaters of the Upper Mojave River Valley Groundwater Basin (Basin No. 6-42). The Mojave River is normally dry with subsurface flows and seasonal surface water runoff.

Effluent discharged at Discharge Point 001 flows through a surface water channel to a series of ponds located on property owned by Victor Valley College, then through a wetland habitat area, over a berm, past a weir, and is eventually discharged into the Mojave River. Some of the water percolates to the riparian aquifer prior to reaching the Mojave River. This channel and associated wetland habitat are considered waters of the United States. As such, the effluent becomes a water of the United States immediately upon discharge at Discharge Point 001.

Approximately 3.3 MGD of effluent is discharged at Discharge Point 002. Effluent discharged at Discharge Point 002 flows through a concrete-lined channel and discharges to Pond 1. Up to 1.5 MGD from Pond 1 may be distributed to a series of five additional ponds for use as irrigation supply water at the golf course. The remaining water is piped to Spring Valley Lake. Effluent mixed with water from additional sources in Spring Valley Lake is discharged directly to the Mojave River upstream of the Lower Narrows or to Pelican Lake. Water from Pelican Lake then flows to Horseshoe Lake. Overflow from Horseshoe Lake flows down a channel that meets the Mojave River at the Lower Narrows. Both Pelican Lake and Horseshoe Lake are located in the flood plain of the Mojave River on property managed by San Bernardino County Mojave Narrows Regional Park. Effluent from Discharge Point 002 also percolates to the riparian aquifer under the Mojave River bed.

While flows are forced to the surface year-round at the Mojave Narrows by uplifted bedrock, flows in the vicinity of the Facility are typically below the surface of the normally dry riverbed. After storm events or snowmelt, water volume in the river may be sufficient to support above ground flows near the Facility. During dry periods, effluent from Discharge Point 001 percolates into the riparian aquifer under the river bed. Even during dry seasons, wetlands and riparian habitat created and maintained by Facility effluent are often present in the Mojave River. Beaver activity in effluent-dominated portions of the effluent channel and riverbed often creates ponds and wetlands in the riverbed that extend beyond Victor Valley Community College property.

C. Summary of Existing Requirements and Self-Monitoring Report (SMR) Data

Effluent limitations contained in Order No. R6V-2011-0081 for discharges from Discharge Points 001 and 002 (measured at Monitoring Location M-001 as defined in Order No. R6V-2011-0081), and representative monitoring data from the term of Order No. R6V-2011-0081 are presented in the table below.

Table F-2. Historic Effluent Limitations and Monitoring Data – Discharge Points 001 and 002

Parameter	Units	Effluent Limitation		Monitoring Data (November 2011 – December 2015)	
		Average Monthly	Maximum Daily	Highest Average Monthly Discharge	Highest Maximum Daily Discharge
Formaldehyde	mg/L	0.65	1.3	NA	NA
Hydrogen Peroxide	mg/L	--	1.3	--	1.4
pH	standard units	--	6.5 – 8.5		6.67 – 8.97
Settleable Solids	mL/L	0.1	--	<0.1	<0.1
Total Suspended Solids (TSS)	mg/L	6.0	15.0 ¹	9	9

¹ Applied as an instantaneous maximum effluent limitation.

D. Compliance Summary

Monitoring data from November 2011 through December 2015 indicated that the Discharger has complied with the effluent limitations of Order No. R6V-2011-0081, except for the effluent limitation exceedances listed in the following table.

Table F-3. Compliance Summary – Discharge Points 001 and 002

Date	Pollutant	Units	Effluent Concentration	Effluent Limitation
October 22, 2012	pH	standard units	8.82	8.5
October 10, 2013	pH	standard units	8.97	8.5
November 19, 2013	pH	standard units	8.89	8.5
February 13, 2014	pH	standard units	8.82	8.5
March 5, 2014	pH	standard units	8.86	8.5
June 9, 2014	pH	standard units	8.95	8.5
January 23, 2015	pH	standard units	8.57	8.5
June 17, 2015	Total Suspended Solids (TSS)	mg/L	9	6.0
December 15, 2015	Hydrogen Peroxide	mg/L	1.4	1.3

The Discharger received a verbal warning on November 20, 2014 from Lahontan Water Board staff for failing to sample the Facility’s effluent for potassium permanganate and hydrogen peroxide on October 10, 2013 and August 1, 2014. The verbal warning also noted the Discharger’s failure to sample its Facility’s effluent for potassium permanganate in January, February, and March, 2014.

In September 2013, May 2014, June 2014, and July 2015 chemical treatments of hydrogen peroxide were administered at the facility and no corresponding sampling results were reported as required. In April 2012, May 2012, June 2012, September 2012, September 2013, January 2014, February 2014, March 2014, June 2014, January 2015, July 2015, August 2015, and December 2015, chemical treatments of potassium permanganate were administered at the facility and no corresponding sampling results were reported as required. These violations stemmed from supervisory absence and transitions at the facility. Since the violations were discovered, the staff has undergone training and proper procedures of reporting to prevent similar violations in the future.

During a March 29, 2013 compliance evaluation inspection, violations of Order No. R6V-2011-0081 were noted. The violation included spills of vehicle fluids to the ground and

discharge of vehicle washing soap and wash water to the storm drain, bypass of untreated wastewater to the adjacent surface water, inadequate secondary containment for one of the aeration towers, insufficient vertical distance between the water surface elevation and the lowest point of a pond dike or the invert of an overflow structure; and algal growth on the flow sensor. A verbal warning was issued by Lahontan Water Board staff at the time of the inspection, which was followed up by a staff enforcement letter a year later on June 2, 2014.

Based on the self-monitoring reports associated with the annual reporting years of 2011 through 2016, calculations of all drug and chemical effluent concentrations were not provided as required by Attachment I of the permit. During this same period, Oxytetracycline and Florfenicol medicated feeds were used at the Facility; however, their use and estimated effluent concentrations were not reported as required by the permit.

E. Planned Changes

In an effort to eliminate a fish disease at the Facility, and consequently reduce the need for drug and chemical use, the Discharger is planning to remove bryozoans, which are host for the disease life cycle, from the surface of the raceways. During the removal process, the raceways will be vacated of all fish and all water through the raceways will be shut-off. The Discharger plans to remove bryozoans using peracetic acid. The raceways will also be cleaned and likely resurfaced, and the settling basin will be dredged. The removal process is tentatively planned for summer 2017. This permit does not authorize the discharge of peracetic acid or solids resulting from the removal of bryozoans from the raceways and from the removal of solids from the settling basin, which must be collected and disposed of in accordance with Special Provision VI.C.4.a of this Order.

The Discharger is planning to construct a new hatchery building in the open area adjacent to the golf course and canal that feeds Spring Valley Lake. The hatchery building is expected to be approximately 80 feet x 60 feet. The water supply for the new hatchery building will be from existing groundwater well #7. A drain will be installed to convey hatchery wastewater to the settling pond. The new hatchery building is not expected to increase the overall flow from the Facility. Upon completion of the new hatchery building, the discharge pipe from the current hatchery building will be capped and the pumping system will be removed.

The Discharger is considering the addition of a storm water diversion to mitigate flooding and property damage during heavy rainfall events.

III. APPLICABLE PLANS, POLICIES, AND REGULATIONS

The requirements contained in this Order are based on the requirements and authorities described in this section.

A. Legal Authorities

This Order serves as WDRs pursuant to article 4, chapter 4, division 7 of the California Water Code (commencing with section 13260). This Order is also issued pursuant to section 402 of the federal Clean Water Act (CWA) and implementing regulations adopted by the USEPA and chapter 5.5, division 7 of the Water Code (commencing with section 13370). It shall serve as an NPDES permit authorizing the Discharger to discharge into waters of the United States at the discharge location described in Table 2 subject to the WDRs in this Order.

B. California Environmental Quality Act (CEQA)

This action to adopt an NPDES permit is exempt from the provisions of chapter 3 of CEQA (Public Resources Code sections 21100, et seq.), pursuant to section 13389 of the Water Code.

C. State and Federal Laws, Regulations, Policies, and Plans

1. Water Quality Control Plan. The Lahontan Water Board adopted a *Water Quality Control Plan for the Lahontan Region* (hereinafter Basin Plan) on March 31, 1995 and most recently amended on April 9, 2014. The Basin Plan designates beneficial uses, establishes water quality objectives, and contains implementation programs and policies to achieve those objectives for all waters addressed through the plan. In addition, the Basin Plan implements State Water Board Resolution No. 88-63, which establishes State policy that all waters, with certain exceptions, should be considered suitable or potentially suitable for municipal or domestic supply (MUN). Thus, beneficial uses applicable to the Mojave River and the Lower Narrows of Mojave River Wetlands in the Upper Mojave Hydrologic Area are as follows:

Table F-4. Surface Water Basin Plan Beneficial Uses

Discharge Point	Receiving Water Name	Beneficial Use(s)
001	Wetlands tributary to the Mojave River (and shallow groundwater)	Municipal and Domestic Supply (MUN); Agricultural Supply (AGR); Groundwater Recharge (GWR); Water Contact Recreation (REC-1); Noncontact Water Recreation (REC-2); Commercial and Sport Fishing (COMM); Warm Freshwater Habitat (WARM); Cold Freshwater Habitat (COLD); Freshwater Replenishment (FRSH); and Wildlife Habitat (WILD).
002	Spring Valley Lake and other minor surface waters, including wetlands	Municipal and Domestic Supply (MUN); Agricultural Supply (AGR); Groundwater Recharge (GWR); Water Contact Recreation (REC-1); Noncontact Water Recreation (REC-2); Warm Freshwater Habitat (WARM); Cold Freshwater Habitat (COLD); Freshwater Replenishment (FRSH); Wildlife Habitat (WILD); Rare, Threatened, or Endangered Species (RARE); Migration of Aquatic Organisms (MIGR); Water Quality Enhancement (WQE); and Flood Peak Attenuation/Flood Water Storage (FLD).

The Basin Plan also identifies beneficial uses of groundwater that are applicable to all groundwater in the Lahontan Region. Beneficial uses of specific groundwater basins in the Lahontan Region are designated in Table 2-2 of the Basin Plan. The Facility is located within the Upper Mojave River Valley Basin. Unless otherwise designated by the Lahontan Water Board, all groundwaters are considered suitable, or potentially suitable, for MUN. The beneficial uses applicable to groundwater in the Upper Mojave River Valley Basin are as follows.

Table F-5. Ground Water Basin Plan Beneficial Uses

Basin Name	Beneficial Use(s)
Upper Mojave River Valley Groundwater Basin	Municipal and Domestic Supply (MUN); Agricultural Supply (AGR); Industrial Service Supply (IND); Freshwater Replenishment (FRSH); and Aquaculture (AQUA).

2. National Toxics Rule (NTR) and California Toxics Rule (CTR). USEPA adopted the NTR on December 22, 1992, and later amended it on May 4, 1995 and

November 9, 1999. About forty criteria in the NTR are applicable in California. On May 18, 2000, USEPA adopted the CTR. The CTR promulgated new toxics criteria for California in addition to the previously adopted NTR criteria that were applicable in the state. The CTR was amended on February 13, 2001. These rules contain federal water quality criteria for priority pollutants.

3. **State Implementation Policy** On March 2, 2000, the State Water Board adopted the *Policy for Implementation of Toxics Standards for Inland Surface Waters, Enclosed Bays, and Estuaries of California* (State Implementation Policy or SIP). The SIP became effective on April 28, 2000, with respect to the priority pollutant criteria promulgated through the NTR and to the priority pollutant objectives established in the Basin Plan. The SIP became effective on May 18, 2000, with respect to the priority pollutant criteria promulgated through the CTR. The State Water Board adopted amendments to the SIP on February 24, 2005, that became effective on July 13, 2005. The SIP establishes implementation provisions for priority pollutant criteria and objectives and provisions for chronic toxicity control. Requirements of this Order implement the SIP.
4. **Alaska Rule.** On March 30, 2000, USEPA revised its regulation that specifies when new and revised state and tribal water quality standards become effective for CWA purposes (65 Fed. Reg. 24641 [April 27, 2000]). New and revised standards submitted to USEPA after May 30, 2000, must be approved by USEPA before being used for CWA purposes. The final rule also provides that standards already in effect and submitted to USEPA by May 30, 2000, may be used for CWA purposes, whether or not approved by USEPA.
5. **Antidegradation Policy.** Federal regulation 40 C.F.R. section 131.12 requires that the state water quality standards include an antidegradation policy consistent with the federal policy. The State Water Board established California's antidegradation policy in State Water Board Resolution 68-16 ("Statement of Policy with Respect to Maintaining High Quality of Waters in California"). Resolution 68-16 is deemed to incorporate the federal antidegradation policy where the federal policy applies under federal law. Resolution 68-16 requires that existing water quality be maintained unless degradation is justified based on specific findings. The Lahontan Water Board's Basin Plan implements, and incorporates by reference, both the state and federal antidegradation policies. The permitted discharge must be consistent with the antidegradation provision of 40 C.F.R. section 131.12 and State Water Board Resolution 68-16.
6. **Anti-Backsliding Requirements.** Sections 402(o) and 303(d)(4) of the CWA and federal regulations at 40 C.F.R. section 122.44(l) restrict backsliding in NPDES permits. These anti-backsliding provisions require that effluent limitations in a reissued permit must be as stringent as those in the previous permit, with some exceptions in which limitations may be relaxed.
7. **Endangered Species Act Requirements.** This Order does not authorize any act that results in the taking of a threatened or endangered species or any act that is now prohibited, or becomes prohibited in the future, under either the California Endangered Species Act (Fish and Game Code, §§ 2050 to 2097) or the Federal Endangered Species Act (16 U.S.C.A. §§ 1531 to 1544). This Order requires compliance with effluent limits, receiving water limits, and other requirements to protect the beneficial uses of waters of the state. The Discharger is responsible for meeting all requirements of the applicable Endangered Species Act.
8. **Regulation of Aquaculture Drugs and Chemicals.** CAAP facilities produce fish and other aquatic animals in greater numbers than natural stream conditions would allow; therefore, system management is important to ensure that fish do not become overly stressed, making them more susceptible to disease outbreaks. The periodic use of

various aquaculture drugs and chemicals is needed to ensure the health and productivity of cultured aquatic stocks and to maintain production efficiency.

Drugs and chemicals used in aquaculture are strictly regulated by the U.S. Food and Drug Administration (FDA) through the Federal Food, Drug, and Cosmetic Act (FFDCA; 21 U.S.C 301-392). FFDCA, the basic food and drug law of the United States, includes provisions for regulating the manufacture, distribution, and the use of, among other things, new animal drugs and animal feed. FDA's Center for Veterinary Medicine (CVM) regulates the manufacture, distribution, and use of animal drugs. CVM is responsible for ensuring that drugs used in food-producing animals are safe and effective and that food products derived from treated animals are free from potentially harmful residues. CVM approves the use of new animal drugs based on data provided by a sponsor (usually a drug company). To be approved by CVM, an animal drug must be effective for the claim on the label, and safe when used as directed for (1) treated animals; (2) persons administering the treatment; (3) the environment, including non-target organisms; and (4) consumers. CVM establishes tolerances and animal withdrawal periods as needed for all drugs approved for use in food-producing animals. CVM has the authority to grant investigational new animal drug (INAD) exemptions so that data can be generated to support the approval of a new animal drug.

CAAP facilities may legally obtain and use aquaculture drugs in one of several ways. Some aquaculture drugs and chemicals used at CAAP facilities are approved by the U.S. Food and Drug Administration (FDA) for certain aquaculture uses on certain aquatic species. Others have an exemption from this approval process when used under certain specified conditions. Others are not approved for use in aquaculture, but are considered to be of "low regulatory priority" by FDA (hereafter "LRP drug"). FDA is unlikely to take regulatory action related to the use of a LRP drug if an appropriate grade of the chemical or drug is used, good management practices are followed, and local environmental requirements are met (including NPDES permit requirements). Finally, some drugs and chemicals may be used for purposes, or in a manner not listed on their label (i.e., "extra-label" use), under the direction of licensed veterinarians for the treatment of specific fish diseases diagnosed by fish pathologists. It is assumed that veterinarian-prescribed aquaculture drugs are used only for short periods of duration during acute disease outbreaks. Each of these methods of obtaining and using aquaculture drugs is discussed in further detail below.

It is the responsibility of the Discharger to know which aquaculture drugs and chemicals may be used in CAAP facilities in the Lahontan Region under all applicable federal, state, and local regulations and which aquaculture drugs and chemicals may be discharged to waters of the United States and waters of the State in accordance with this permit. A summary of regulatory authorities related to aquaculture drugs and chemicals is outlined below.

a. FDA Approved New Animal Drugs

Approved new animal drugs have been screened by the FDA to determine whether they cause significant adverse public health or environmental impacts when used in accordance with label instructions. Currently, there are ten new animal drugs approved by FDA for use in food-producing aquatic species. These ten FDA-approved new animal drugs include the following:

- i. Chorionic gonadotropin (Chlorulun®), used for spawning;
- ii. Oxytetracycline hydrochloride (Terramycin®), an antibiotic;
- iii. Oxytetracycline dihydrate (Terramycin® 200 for fish), an antibiotic and bacteriostat;

- iv. Sulfadimethoxine-ormetoprim (Romet-30®), an antibiotic;
- v. Tricaine methanesulfonate (MS-222, Finquel® and Tricaine-S), an anesthetic;
- vi. Formalin (Formalin-F®, Paracide F® and PARASITE-S®), used as a fungus and parasite treatment;
- vii. Sulfamerazine, an antibiotic;
- viii. Chloramine-T (HALAMID® Aqua), an antibiotic;
- ix. Florfenicol (Aquaflor®), an antibiotic; and
- x. Hydrogen peroxide, used to control fungal and bacterial infections.

Each aquaculture drug in this category is approved by the FDA for use on specific fish species, for specific disease conditions, at specific dosages, and with specific withdrawal times. Product withdrawal times must be observed to ensure that any product used on aquatic animals at a CAAP facility does not exceed legal tolerance levels in the animal tissue. Observance of the proper withdrawal time helps ensure that products reaching consumers are safe and wholesome.

FDA-approved new animal drugs that are added to aquaculture feed must be specifically approved for use in aquaculture feed. Drugs approved by FDA for use in feed must be found safe and effective. Approved new animal drugs may be mixed in feed for uses and at levels that are specified in FDA medicated-feed regulations only. It is unlawful to add drugs to feed unless the drugs are approved for such feed use. For example, producers may not top-dress feed with a water-soluble, over-the-counter antibiotic product. Some medicated feeds, such as Romet-30®, may be manufactured only after the FDA has approved a medicated-feed application (FDA Form 1900) submitted by the feed manufacturer.

b. FDA Investigational New Animal Drug (INAD)

Aquaculture drugs in this category can only be used under an investigational new animal drug or "INAD" exemption. INAD exemptions are granted by FDA CVM to permit the purchase, shipment and use of an unapproved new animal drug for investigational purposes. INAD exemptions are granted by FDA CVM with the expectation that meaningful data will be generated to support the approval of a new animal drug by FDA in the future. Numerous FDA requirements must be met for the establishment and maintenance of aquaculture INADs.

There are two types of INADs: standard and compassionate. Aquaculture INADs, most of which are compassionate, consist of two types: routine and emergency. A compassionate INAD exemption is used in cases in which the aquatic animal's health is of primary concern. In certain situations, producers can use unapproved drugs for clinical investigations (under a compassionate INAD exemption) subject to FDA approval. In these cases, CAAP facilities are used to conduct closely monitored clinical field trials. FDA reviews test protocols, authorizes specific conditions of use, and closely monitors any drug use under an INAD exemption. An application to renew an INAD exemption is required each year. Data recording and reporting are required under the INAD exemption in order to support the approval of a new animal drug or an extension of approval for new uses of the drug.

c. FDA Unapproved New Animal Drugs of Low Regulatory Priority (LRP drugs)

LRP drugs do not require a new animal drug application (NADA) or INAD exemptions from FDA. Further regulatory action is unlikely to be taken by FDA on LRP drugs as long as an appropriate grade of the drug or chemical is used, good management practices are followed, and local environmental requirements are met

(such as NPDES permit requirements contained in this Order). LRP drugs commonly used at CAAP facilities include the following:

- i. Acetic acid, used as a dip at a concentration of 1,000-2,000 mg/L for 1-10 minutes as a parasiticide.
- ii. Carbon dioxide gas, used for anesthetic purposes.
- iii. Povidone iodine (PVP) compounds, used as a fish egg disinfectant at rates of 50 mg/L for 30 minutes during egg hardening and 100 mg/L solution for 10 minutes after water hardening.
- iv. Sodium bicarbonate (baking soda), used at 142-642 mg/L for 5 minutes as a means of introducing carbon dioxide into the water to anesthetize fish.
- v. Sodium chloride (salt), used at 0.5-1 % solution for an indefinite period as an osmoregulatory aid for the relief of stress and prevention of shock. Used as 3% solution for 10-30 minutes as a parasiticide.
- vi. Potassium permanganate is a LRP that regulatory action has been deferred pending further study.

FDA is unlikely to object at present to the use of these LRP drugs if the following conditions are met:

- i. The aquaculture drugs are used for the prescribed indications, including species and life stages where specified.
- ii. The aquaculture drugs are used at the prescribed dosages (as listed above).
- iii. The aquaculture drugs are used according to good management practices.
- iv. The product is of an appropriate grade for use in food animals.
- v. An adverse effect on the environment is unlikely.

FDA's enforcement position on the use of these substances should be considered neither an approval nor an affirmation of their safety and effectiveness. Based on information available in the future, FDA may take a different position on their use. In addition, FDA notes that classification of substances as new animal drugs of LRP does not exempt CAAP facilities from complying with all other federal, state and local environmental requirements, including compliance with this Order.

d. Extra-label Use of an Approved New Animal Drug

Extra-label drug use is the actual or intended use of an approved new animal drug in a manner that is not in accordance with the approved label directions. This includes, but is not limited to, use on species or for indications not listed on the label. Only a licensed veterinarian may prescribe extra-label drugs under FDA CVM's extra-label drug use policy. CVM's extra-label use drug policy (CVM Compliance Policy Guide 7125.06) states that licensed veterinarians may consider extra-label drug use in treating food-producing animals if the health of the animals is immediately threatened and if further suffering or death would result from failure to treat the affected animals. CVM's extra-label drug use policy does not allow the use of drugs to prevent diseases (prophylactic use), improve growth rates, or enhance reproduction or fertility. Spawning hormones cannot be used under the extra-label policy. In addition, the veterinarian assumes the responsibility for drug safety and efficacy and for potential residues in the aquatic animals.

D. Impaired Water Bodies on the CWA Section 303(d) List

In 26 June 2015, USEPA gave final approval to California's 2012 list of impaired water bodies prepared pursuant to CWA section 303(d), which requires identification of specific water bodies where it is expected that water quality standards will not be met after implementation of technology-based effluent limitations on point sources. Where it has not done so already, the Lahontan Water Board plans to adopt Total Maximum Daily Loads (TMDLs) for pollutants on the 303(d) list. TMDLs establish waste load allocations for point sources and load allocations for non-point sources, and are established to achieve the water quality standards for the impaired water bodies.

The Mojave River from the Mojave Forks Reservoir outlet to the Upper Narrows is listed on the 2012 303(d) list as impaired for fluoride. The source of the fluoride impairment is from natural sources. The Mojave River from the Upper Narrows to the Lower Narrows is listed on the 2012 303(d) list as impaired for fluoride, sulfates, and total dissolved solids. The source of the fluoride impairment is from natural sources. The source of the sulfate impairment is from natural sources and nonpoint sources. The source of the total dissolved solids impairment is unknown. The proposed TMDLs for these constituents are not scheduled for completion until 2021, although additional studies are needed to verify whether impairment exists and whether a TMDL is needed.

E. Other Plans, Policies and Regulations – Not Applicable

IV. RATIONALE FOR EFFLUENT LIMITATIONS AND DISCHARGE SPECIFICATIONS

The CWA requires point source dischargers to control the amount of conventional, non-conventional, and toxic pollutants that are discharged into the waters of the United States. The control of pollutants discharged is established through effluent limitations and other requirements in NPDES permits. There are two principal bases for effluent limitations in the Code of Federal Regulations: 40 C.F.R. section 122.44(a) requires that permits include applicable technology-based limitations and standards; and 40 C.F.R. section 122.44(d) requires that permits include water quality-based effluent limitations (WQBELs) to attain and maintain applicable numeric and narrative water quality criteria to protect the beneficial uses of the receiving water.

A. Discharge Prohibitions

1. The discharge prohibitions established in this Order are from waste discharge prohibitions in the Basin Plan that apply to the entire Lahontan Region (section 4.1) or based on discharge prohibitions specified in the Water Code.
2. As stated in section I.G of Attachment D, Standard Provisions, this Order prohibits bypass from any portion of a treatment facility. Federal Regulations, 40 C.F.R. section 122.41(m), defines "bypass" as the intentional diversion of waste streams from any portion of a treatment facility. This section of the Federal Regulations, 40 C.F.R. section 122.41(m)(4), prohibits bypass unless it is unavoidable to prevent loss of life, personal injury, or severe property damage. In considering the Water Board's prohibition of bypasses, the State Water Board adopted a precedential decision, Order No. WQO 2002-0015, which cites the Federal Regulations, 40 C.F.R. section 122.41(m), as allowing bypass only for essential maintenance to assure efficient operation.
3. Consistent with Order No. R6V-2011-0081, this Order includes storm water runoff and storm water collection system prohibitions and requirements, including visual observations within 2 business days of a qualifying rain event and quarterly non-storm water inspections.

B. Technology-Based Effluent Limitations

1. Scope and Authority

Section 301(b) of the CWA and implementing USEPA permit regulations at 40 C.F.R. section 122.44 require that permits include conditions meeting applicable technology-based requirements at a minimum, and any more stringent effluent limitations necessary to meet applicable water quality standards. The discharge authorized by this Order must meet minimum federal technology-based requirements based on Best Professional Judgment (BPJ) in accordance with 40 C.F.R. section 125.3.

The CWA requires that technology-based effluent limitations be established based on several levels of controls:

- a. Best practicable treatment control technology (BPT) represents the average of the best existing performance by well-operated facilities within an industrial category or subcategory. BPT standards apply to toxic, conventional, and non-conventional pollutants.
- b. Best available technology economically achievable (BAT) represents the best existing performance of treatment technologies that are economically achievable within an industrial point source category. BAT standards apply to toxic and non-conventional pollutants.
- c. Best conventional pollutant control technology (BCT) represents the control from existing industrial point sources of conventional pollutants including biochemical oxygen demand (BOD), total suspended solids (TSS), fecal coliform, pH, and oil and grease. The BCT standard is established after considering a two-part reasonableness test. The first test compares the relationship between the costs of attaining a reduction in effluent discharge and the resulting benefits. The second test examines the cost and level of reduction of pollutants from the discharge from publicly owned treatment works to the cost and level of reduction of such pollutants from a class or category of industrial sources. Effluent limitations must be reasonable under both tests.
- d. New source performance standards (NSPS) represent the best available demonstrated control technology standards. The intent of NSPS guidelines is to set limitations that represent state-of-the-art treatment technology for new sources.

The CWA requires USEPA to develop effluent limitations, guidelines and standards (ELGs) representing application of BPT, BAT, BCT, and NSPS. Section 402(a)(1) of the CWA and 40 C.F.R. section 125.3 authorize the use of BPJ to derive technology-based effluent limitations on a case-by-case basis where ELGs are not available for certain industrial categories and/or pollutants of concern. Where BPJ is used (i.e., where no applicable ELGs exist), the Lahontan Water Board must consider specific factors outlined in 40 C.F.R. section 125.3.

A CAAP facility is defined in 40 C.F.R. section 122.24 as a fish hatchery, fish farm, or other facility that contains, grows, or holds cold water fish species or other cold water aquatic animals including, but not limited to, the *Salmonidae* family of fish (e.g., trout and salmon) in ponds, raceways, or other similar structures. In addition, the facility must discharge at least 30 calendar days per year, produce at least 20,000 pounds (9,090 kilograms) harvest weight of aquatic animals per year, and feed at least 5,000 pounds (2,272 kilograms) of food during the calendar month of maximum feeding. A facility that does not meet the above criteria may also be designated a cold water CAAP facility upon a determination that the facility is a significant contributor of pollution to waters of the United States [40 C.F.R. § 122.24(c)]. Cold water, flow-through CAAP facilities are designed to allow the continuous flow of fresh water through tanks and raceways used to produce aquatic animals (typically cold water fish species). Flows from

CAAP facilities ultimately are discharged to waters of the United States and of the State. 40 C.F.R. section 122.24 specifies that CAAP facilities are point sources subject to the NPDES program.

The operation of CAAP facilities may introduce a variety of pollutants into receiving waters. USEPA identifies three classes of pollutants: (1) conventional pollutants (i.e., TSS, oil and grease, BOD, fecal coliforms, and pH); (2) toxic pollutants (e.g., metals such as copper, lead, nickel, and zinc and other toxic pollutants); and (3) non-conventional pollutants (e.g., ammonia-N, Formalin, and phosphorus). Some of the most significant pollutants discharged from CAAP facilities are solids from uneaten feed and fish feces that settle to the bottom of the raceways. Both of these types of solids are primarily composed of organic matter including BOD, organic nitrogen, and organic phosphorus.

Fish raised in CAAP facilities may become vulnerable to disease and parasite infestations. Various aquaculture drugs and chemicals are used periodically at CAAP facilities to ensure the health and productivity of the confined fish population, as well as to maintain production efficiency. Aquaculture drugs and chemicals are used to clean raceways and to treat fish for parasites, fungal growths and bacterial infections. Aquaculture drugs and chemicals are sometimes used to anesthetize fish prior to spawning or "tagging" processes. As a result of these operations and practices, drugs and chemicals may be present in discharges to waters of the United States or waters of the State.

On August 23, 2004 USEPA published ELGs for the Concentrated Aquatic Animal Production Point Source Category (40 C.F.R. part 451). The ELGs became effective on September 22, 2004. The ELGs establish national technology-based effluent discharge requirements for flow-through and recirculation systems and for net pens based on BPT, BCT, BAT and NSPS. In its proposed rule, published on September 12, 2002, USEPA proposed to establish numeric limitations for a single pollutant –TSS – while controlling the discharge of other pollutants through narrative requirements. In the final rule, however, USEPA determined that, for a nationally applicable regulation, it would be more appropriate to promulgate qualitative TSS limitations in the form of solids control best management practices (BMP) requirements.

In the process of developing the ELGs, USEPA identified an extensive list of pollutants of concern in discharges from the aquaculture industry, including several metals, nutrients, solids, BOD, bacteria, drugs, and residuals of federally registered pesticides. USEPA did not include specific numerical limitations in the ELG for any pollutants on this list, believing that BMPs would provide acceptable control of these pollutants. USEPA did conclude during the development of the ELG that control of suspended solids would also effectively control concentrations of other pollutants of concern, such as BOD, metals and nutrients, because other pollutants are either bound to the solids or are incorporated into them. And, although certain bacteria are found at high levels in effluents from settling basins, USEPA concluded that disinfection is not economically achievable. USEPA also allowed permitting authorities to apply technology-based effluent limitations for other pollutants and WQBELs for pollutants considered in the ELG in order to comply with applicable water quality standards.

2. Applicable Technology-Based Effluent Limitations

- a. **Total Suspended Solids (TSS).** Technology-based requirements in this Order are based on a combination of application of the ELGs for BMP requirements and case-by-case numeric limitations developed using BPJ and carried over from Order R6V-2011-0081. The effluent limitations for TSS, 6.0 mg/L as an average monthly effluent limitation (AMEL) and 15 mg/L as an instantaneous maximum, are

continued in this Order from Order R6V-2011-0081. Section 402(o) of the CWA prohibits backsliding of effluent limitations that are based on BPJ to reflect a subsequently promulgated ELG which is less stringent. Removal of the numeric limitations for TSS would constitute backsliding under CWA Section 402(o). These limitations were established prior to the issuance of the ELG and were established as a means of controlling the discharge of solids from algae, silt, fish feces and uneaten feed.

Existing wastewater treatment technology (such as settling basins and vacuum cleaning) is capable of dependably removing solids (primarily fish feces and uneaten feed) from CAAP facility effluent prior to discharge. This Facility utilizes one full-flow settling pond prior to discharge. Existing self-monitoring data show the Facility is able to reliably meet the numeric effluent limitations for TSS using existing wastewater treatment and control technologies, and implementation of BMPs.

This Order does not contain mass effluent limitations for TSS because there are no standards that specifically require a mass-based effluent limitation, and mass of the pollutant discharged is not specifically related to a measure of operation [40 C.F.R. § 122.45(f)(iii)]. This is consistent with Order R6V-2011-0081, which did not include mass effluent limitations.

- b. Flow.** Consistent with Order R6V-2011-0081, this Order does not include an effluent limitation for flow because the Facility’s pumping infrastructure limits the amount of water used at the Facility and because compliance with effluent limitations for TSS and settleable solids ensures that flows exceeding the treatment capacity of the Facility will not be discharged. This Order requires the Discharger to measure the total combined flow from Discharge Points 001 and 002 at Monitoring Location EFF-001.

**Summary of Technology-Based Effluent Limitations
 Discharge Points 001 and 002**

Table F-6. Summary of Technology-Based Effluent Limitations

Parameter	Units	Effluent Limitations			
		Average Monthly	Maximum Daily	Instantaneous Minimum	Instantaneous Maximum
Total Suspended Solids	mg/L	6.0	--	--	15.0

C. Water Quality-Based Effluent Limitations (WQBELs)

1. Scope and Authority

CWA section 301(b) and 40 C.F.R. section 122.44(d) require that permits include limitations more stringent than applicable federal technology-based requirements where necessary to achieve applicable water quality standards.

Section 122.44(d)(1)(i) of 40 C.F.R. requires that permits include effluent limitations for all pollutants that are or may be discharged at levels that have the reasonable potential to cause or contribute to an exceedance of a water quality standard, including numeric and narrative objectives within a standard. Where reasonable potential has been established for a pollutant, but there is no numeric criterion or objective for the pollutant, WQBELs must be established using: (1) USEPA criteria guidance under CWA section 304(a), supplemented where necessary by other relevant information; (2) an indicator parameter for the pollutant of concern; or (3) a calculated numeric water quality criterion, such as a proposed state criterion or policy interpreting the state’s narrative

criterion, supplemented with other relevant information, as provided in section 122.44(d)(1)(vi).

The process for determining reasonable potential and calculating WQBELs when necessary is intended to protect the designated uses of the receiving water as specified in the Basin Plan, and achieve applicable water quality objectives and criteria that are contained in other state plans and policies, or any applicable water quality criteria contained in the CTR and NTR.

2. **Applicable Beneficial Uses and Water Quality Criteria and Objectives**

The Basin Plan designates beneficial uses, establishes water quality objectives, and contains implementation programs and policies to achieve those objectives for all waters addressed through the plan. In addition, the Basin Plan implements State Water Board Resolution No. 88-63, which established state policy that all waters, with certain exceptions, should be considered suitable or potentially suitable for municipal or domestic supply.

The federal CWA section 101(a)(2), states: *“it is the national goal that wherever attainable, an interim goal of water quality which provides for the protection and propagation of fish, shellfish, and wildlife, and for recreation in and on the water be achieved by July 1, 1983.”* Federal Regulations, developed to implement the requirements of the CWA, create a rebuttable presumption that all waters be designated as fishable and swimmable. Federal Regulations, 40 C.F.R. sections 131.2 and 131.10, require that all waters of the State be regulated to protect the beneficial uses of public water supply, protection and propagation of fish, shell fish and wildlife, recreation in and on the water, agricultural, industrial and other purposes including navigation. Section 131.3(e), 40 C.F.R., defines existing beneficial uses as those uses actually attained after November 28, 1975, whether or not they are included in the water quality standards. Federal Regulation, 40 C.F.R. section 131.10 requires that uses be obtained by implementing effluent limitations, requires that all downstream uses be protected and states that in no case shall a state adopt waste transport or waste assimilation as a beneficial use for any waters of the United States.

a. **Receiving Water and Beneficial Uses**

The Facility discharges wastewater to the Mojave River and minor surface waters that are tributary to the Mojave River, waters of the United States. The beneficial uses applicable to the Mojave River in the Upper Mojave Hydrologic Area are presented in Table F-4.

b. **Water Quality Objectives**

The water quality objectives applicable to the receiving water for this discharge are from the Basin Plan; the CTR, established by USEPA at 40 C.F.R. section 131.38; and the NTR, established by USEPA at 40 C.F.R. section 131.36. Some pollutants have water quality objectives established by more than one of these sources.

- i. **Basin Plan.** The Basin Plan specifies numeric and narrative water quality objectives applicable to all water bodies in the Lahontan Region. The narrative toxicity objective states, *“All waters shall be maintained free of toxic substances in concentrations that are toxic to, or that produce detrimental physiological responses in human, plant, animal, or aquatic life.”* The narrative chemical constituents objective states, *“Waters shall not contain concentrations of chemical constituents in amounts that adversely affect the water for beneficial uses.”*

The Basin Plan also includes the following site-specific numeric water quality objectives applicable to the Mojave River (at Victorville) which is located downstream of the Facility discharge.

Table F-7. Basin Plan Water Quality Objectives for the Mojave River (at Victorville)

Parameter	Annual Average ¹ (mg/L)	90 th Percentile ² (mg/L)
Boron	0.2	0.3
Chloride	75	100
Fluoride	0.2	1.5
Sulfate	40	100

¹ Arithmetic mean of all data collected in a 1-year period.

² Only 10 percent of data can exceed this value.

The Basin Plan also contains the following site-specific numeric WQOs for the West Fork Mojave River (at Lower Narrows). The Lower Narrows are downstream of Discharge Point 001. Flows from Discharge Point 002 enter the Mojave River at the Lower Narrows.

Table F-8. Basin Plan Water Quality Objectives for the West Fork Mojave River (at Lower Narrows)

Parameter	Maximum (mg/L)
Nitrate (as NO ₃)	5
Total Dissolved Solids (TDS)	312

Effluent limitations and provisions contained in this Order are designed to implement these objectives, based on available information.

- ii. **CTR.** The CTR specifies numeric aquatic life criteria for 23 priority toxic pollutants and numeric human health criteria for 57 priority toxic pollutants. These criteria apply to all inland surface waters and enclosed bays and estuaries. Human health criteria are further identified as for “water and organisms” or for “organisms only.”
- iii. **NTR.** The NTR establishes numeric aquatic life criteria for selenium and numeric human health criteria for 33 toxic organic pollutants.

3. Determining the Need for WQBELs

Assessing whether a pollutant has reasonable potential to exceed a water quality objective in the water body is the fundamental step in determining whether or not a WQBEL is required.

a. Reasonable Potential Analysis (RPA) Methodology

According to SIP section 1.3, the RPA begins with identifying the observed maximum effluent concentration (MEC) for each pollutant based on effluent concentration data. There are three triggers in determining reasonable potential:

- i. Trigger 1 is activated if the MEC is greater than or equal to the lowest applicable water quality objective ($MEC \geq$ water quality objective), which has been adjusted, if appropriate, for pH, hardness, and translator data. If the MEC is greater than or equal to the adjusted water quality objective, then that pollutant has reasonable potential, and a WQBEL is required.
- ii. Trigger 2 is activated if the observed maximum ambient background concentration (B) is greater than the adjusted water quality objective ($B >$ water quality objective) and the pollutant is detected in any of the effluent samples.

- iii. Trigger 3 is activated if a review of other information determines that a WQBEL is required to protect beneficial uses, even though both MEC and B are less than the water quality objective.

In order to maintain consistency in methodology for permitting discharges of various constituents, the Lahontan Water Board used the same procedures required by the SIP for CTR constituents to evaluate reasonable potential and, where necessary, develop WQBELs for non-CTR constituents. For constituents with no promulgated numeric water quality criteria or objectives, the Lahontan Water Board interpreted narrative objectives from the Basin Plan to establish the basis for reasonable potential and effluent limitation calculations.

b. Data and Information Used for the RPA

The following describes the data used to perform an RPA for discharges from Discharge Points 001 and 002.

- i. **Effluent Data.** The effluent monitoring data collected by the Discharger during the term of Order No. R6V-2011-0081 and the nature of the discharge from Discharge Points 001 and 002 were analyzed to determine if the discharges have reasonable potential. The RPA was based on effluent monitoring data collected by the Discharger between November 2011 and December 2015.
 - ii. **Hardness.** Some freshwater metal objectives are hardness-dependent. The lower the hardness, the more stringent the resulting criterion is. Effluent hardness data was collected by the Discharger during the term of Order No. R6V-2011-0081, which ranged from 65 mg/L to 85 mg/L (as CaCO₃). The low end of the range was used to determine the objectives for this Order.
 - iii. **Ambient Background Data.** The channel and wetlands to which the Facility discharges at Discharge Point 001 is effluent dominated. The golf course ponds, Spring Valley Lake, Horseshoe Lake, and Pelican Lake consist of effluent mixed with water from additional sources. Thus, no physical upstream receiving water monitoring locations exist outside the influence of the discharges. Consequently, Order No. R6V-2011-0081 did not require receiving water monitoring and ambient background data is not available.
 - iv. **Assimilative Capacity/Mixing Zones.** As no background receiving water exists as described in the section above, no assimilative capacity or mixing zones exist for the discharge from the Facility.
- c. Reasonable Potential Analysis for Priority Pollutants.** The MECs and the most stringent applicable water quality objectives used in the RPA are presented in the following table, along with the RPA results for each pollutant. Reasonable potential was not determined for all pollutants because there are no water quality objectives for all pollutants, and monitoring data are unavailable for others. Based on a review of the effluent data collected during the term of Order No. R6V-2011-0081 (i.e., November 2011 through December 2015), the discharges do not exhibit reasonable potential to cause or contribute to an exceedance of the applicable water quality objectives for priority pollutants.

A potential source of copper (a priority pollutant identified in the NTR and CTR) in discharges from fish hatcheries is from the use of copper sulfate and chelated copper compounds to control the growth of external parasites and bacteria on fish. On January 11, 2010, the Director of Fish and Wildlife certified that "*the use of*

copper sulfate products has been discontinued at all DFG hatcheries." Therefore, effluent limits and monitoring requirements for are not required in this Order.

Table F-9. Reasonable Potential Analysis Summary for Discharge Point 001

CTR No.	Priority Pollutants	Governing Water Quality Objective (µg/L)	MEC or Minimum DL ^{1,2} (µg/L)	Maximum Background or Minimum DL ^{1,2} (µg/L)	RPA Results ³
1	Antimony	6.0	Not Available	Not Available	Undetermined
2	Arsenic	10	2.0	Not Available	Undetermined
3	Beryllium	4.0	<0.033	Not Available	No Limit
4	Cadmium	1.8	<0.041	Not Available	No Limit
5a	Chromium (III)	145	0.76	Not Available	Undetermined
5b	Chromium (VI)	11	0.70	Not Available	Undetermined
6	Copper	6.5	0.19	Not Available	Undetermined
7	Lead	1.8	<0.031	Not Available	No Limit
8	Mercury	0.050	<0.0039	Not Available	No Limit
9	Nickel	36	<0.045	Not Available	No Limit
10	Selenium	5.0	<0.14	Not Available	No Limit
11	Silver	1.9	0.08	Not Available	Undetermined
12	Thallium	1.7	0.03	Not Available	Undetermined
13	Zinc	83	2.1	Not Available	Undetermined
14	Cyanide	5.2	<0.48	Not Available	No Limit
15	Asbestos	7.0	Not Available	Not Available	Undetermined
16	2,3,7,8-TCDD	0.00000013	Not Available	Not Available	Undetermined
	Dioxin TEQ	0.00000013	Not Available	Not Available	Undetermined
17	Acrolein	320	Not Available	Not Available	Undetermined
18	Acrylonitrile	0.059	Not Available	Not Available	Undetermined
19	Benzene	1.0	Not Available	Not Available	Undetermined
20	Bromoform	4.3	Not Available	Not Available	Undetermined
21	Carbon Tetrachloride	0.25	Not Available	Not Available	Undetermined
22	Chlorobenzene	70	Not Available	Not Available	Undetermined
23	Chlorodibromomethane	0.41	Not Available	Not Available	Undetermined
24	Chloroethane	No Criteria	Not Available	Not Available	Undetermined
25	2-Chloroethylvinyl ether	No Criteria	Not Available	Not Available	Undetermined
26	Chloroform	No Criteria	Not Available	Not Available	Undetermined
27	Dichlorobromomethane	0.56	Not Available	Not Available	Undetermined
28	1,1-Dichloroethane	5.0	Not Available	Not Available	Undetermined
29	1,2-Dichloroethane	0.38	Not Available	Not Available	Undetermined
30	1,1-Dichloroethylene	0.057	Not Available	Not Available	Undetermined
31	1,2-Dichloropropane	0.52	Not Available	Not Available	Undetermined
32	1,3-Dichloropropylene	0.50	Not Available	Not Available	Undetermined
33	Ethylbenzene	300	Not Available	Not Available	Undetermined
34	Methyl Bromide	48	Not Available	Not Available	Undetermined
35	Methyl Chloride	No Criteria	Not Available	Not Available	Undetermined
36	Methylene Chloride	4.7	Not Available	Not Available	Undetermined
37	1,1,2,2-Tetrachloroethane	0.17	Not Available	Not Available	Undetermined
38	Tetrachloroethylene	0.80	Not Available	Not Available	Undetermined
39	Toluene	150	Not Available	Not Available	Undetermined
40	1,2-Trans-Dichloroethylene	0.010	Not Available	Not Available	Undetermined
41	1,1,1-Trichloroethane	200	Not Available	Not Available	Undetermined
42	1,1,2-Trichloroethane	0.60	Not Available	Not Available	Undetermined
43	Trichloroethylene	2.7	Not Available	Not Available	Undetermined
44	Vinyl Chloride	0.50	Not Available	Not Available	Undetermined

CTR No.	Priority Pollutants	Governing Water Quality Objective (µg/L)	MEC or Minimum DL ^{1,2} (µg/L)	Maximum Background or Minimum DL ^{1,2} (µg/L)	RPA Results ³
45	2-Chlorophenol	120	Not Available	Not Available	Undetermined
46	2,4-Dichlorophenol	93	Not Available	Not Available	Undetermined
47	2,4-Dimethylphenol	540	Not Available	Not Available	Undetermined
48	2-Methyl- 4,6-Dinitrophenol	13	Not Available	Not Available	Undetermined
49	2,4-Dinitrophenol	70	Not Available	Not Available	Undetermined
50	2-Nitrophenol	No Criteria	Not Available	Not Available	Undetermined
51	4-Nitrophenol	No Criteria	Not Available	Not Available	Undetermined
52	3-Methyl 4-Chlorophenol	No Criteria	Not Available	Not Available	Undetermined
53	Pentachlorophenol	0.28	Not Available	Not Available	Undetermined
54	Phenol	21,000	Not Available	Not Available	Undetermined
55	2,4,6-Trichlorophenol	2.1	Not Available	Not Available	Undetermined
56	Acenaphthene	1,200	Not Available	Not Available	Undetermined
57	Acenaphthylene	No Criteria	Not Available	Not Available	Undetermined
58	Anthracene	9,600	Not Available	Not Available	Undetermined
59	Benzidine	0.00012	Not Available	Not Available	Undetermined
60	Benzo(a)Anthracene	0.0044	Not Available	Not Available	Undetermined
61	Benzo(a)Pyrene	0.0044	Not Available	Not Available	Undetermined
62	Benzo(b)Fluoranthene	0.0044	Not Available	Not Available	Undetermined
63	Benzo(ghi)Perylene	No Criteria	Not Available	Not Available	Undetermined
64	Benzo(k)Fluoranthene	0.0044	Not Available	Not Available	Undetermined
65	Bis(2-Chloroethoxy)Methane	No Criteria	Not Available	Not Available	Undetermined
66	Bis(2-Chloroethyl)Ether	0.031	Not Available	Not Available	Undetermined
67	Bis(2-Chloroisopropyl)Ether	1,400	Not Available	Not Available	Undetermined
68	Bis(2-Ethylhexyl)Phthalate	1.8	Not Available	Not Available	Undetermined
69	4-Bromophenyl Phenyl Ether	No Criteria	Not Available	Not Available	Undetermined
70	Butylbenzyl Phthalate	3,000	Not Available	Not Available	Undetermined
71	2-Chloronaphthalene	1,700	Not Available	Not Available	Undetermined
72	4-Chlorophenyl Phenyl Ether	No Criteria	Not Available	Not Available	Undetermined
73	Chrysene	0.0044	Not Available	Not Available	Undetermined
74	Dibenzo(a,h)Anthracene	0.0044	Not Available	Not Available	Undetermined
75	1,2-Dichlorobenzene	600	Not Available	Not Available	Undetermined
76	1,3-Dichlorobenzene	400	Not Available	Not Available	Undetermined
77	1,4-Dichlorobenzene	5.0	Not Available	Not Available	Undetermined
78	3,3 Dichlorobenzidine	0.040	Not Available	Not Available	Undetermined
79	Diethyl Phthalate	23,000	Not Available	Not Available	Undetermined
80	Dimethyl Phthalate	313,000	Not Available	Not Available	Undetermined
81	Di-n-Butyl Phthalate	2,700	Not Available	Not Available	Undetermined
82	2,4-Dinitrotoluene	0.11	Not Available	Not Available	Undetermined
83	2,6-Dinitrotoluene	No Criteria	Not Available	Not Available	Undetermined
84	Di-n-Octyl Phthalate	No Criteria	Not Available	Not Available	Undetermined
85	1,2-Diphenylhydrazine	0.040	Not Available	Not Available	Undetermined
86	Fluoranthene	300	Not Available	Not Available	Undetermined
87	Fluorene	1,300	Not Available	Not Available	Undetermined
88	Hexachlorobenzene	0.00075	Not Available	Not Available	Undetermined
89	Hexachlorobutadiene	0.44	Not Available	Not Available	Undetermined
90	Hexachlorocyclopentadiene	50	Not Available	Not Available	Undetermined
91	Hexachloroethane	1.9	Not Available	Not Available	Undetermined
92	Indeno(1,2,3-cd)Pyrene	0.0044	Not Available	Not Available	Undetermined

CTR No.	Priority Pollutants	Governing Water Quality Objective (µg/L)	MEC or Minimum DL ^{1,2} (µg/L)	Maximum Background or Minimum DL ^{1,2} (µg/L)	RPA Results ³
93	Isophorone	8.4	Not Available	Not Available	Undetermined
94	Naphthalene	No Criteria	Not Available	Not Available	Undetermined
95	Nitrobenzene	17	Not Available	Not Available	Undetermined
96	N-Nitrosodimethylamine	0.00069	Not Available	Not Available	Undetermined
97	N-Nitrosodi-n-Propylamine	0.0050	Not Available	Not Available	Undetermined
98	N-Nitrosodiphenylamine	5.0	Not Available	Not Available	Undetermined
99	Phenanthrene	No Criteria	Not Available	Not Available	Undetermined
100	Pyrene	960	Not Available	Not Available	Undetermined
101	1,2,4-Trichlorobenzene	5.0	Not Available	Not Available	Undetermined
102	Aldrin	0.00013	Not Available	Not Available	Undetermined
103	Alpha-BHC	0.0039	Not Available	Not Available	Undetermined
104	Beta-BHC	0.014	Not Available	Not Available	Undetermined
105	Gamma-BHC	0.019	Not Available	Not Available	Undetermined
106	Delta-BHC	No Criteria	Not Available	Not Available	Undetermined
107	Chlordane	0.00057	Not Available	Not Available	Undetermined
108	4,4'-DDT	0.00059	Not Available	Not Available	Undetermined
109	4,4'-DDE (linked to DDT)	0.00059	Not Available	Not Available	Undetermined
110	4,4'-DDD	0.00083	Not Available	Not Available	Undetermined
111	Dieldrin	0.00014	Not Available	Not Available	Undetermined
112	Alpha-Endosulfan	0.056	Not Available	Not Available	Undetermined
113	beta-Endosulfan	0.056	Not Available	Not Available	Undetermined
114	Endosulfan Sulfate	110	Not Available	Not Available	Undetermined
115	Endrin	0.036	Not Available	Not Available	Undetermined
116	Endrin Aldehyde	0.76	Not Available	Not Available	Undetermined
117	Heptachlor	0.00021	Not Available	Not Available	Undetermined
118	Heptachlor Epoxide	0.00010	Not Available	Not Available	Undetermined
119-125	PCBs sum	0.00017	Not Available	Not Available	Undetermined
126	Toxaphene	0.00020	Not Available	Not Available	Undetermined

¹ The MEC and maximum background concentration are the actual detected concentrations unless preceded by a “<” sign, in which case the value shown is the minimum detection level (DL).

² The MEC or maximum background concentration is “Not Available” when there are no monitoring data for the constituent.

³ RPA Results = Limit Required, if MEC > WQO, B > WQO and MEC is detected, or Trigger 3;
 = No Limit, if MEC and B are < WQO or all effluent data are undetected; or
 = Undetermined, if no criteria have been promulgated or there are insufficient data.

d. Reasonable Potential Analysis for Non-Conventional Pollutants

i. Constituents with No Reasonable Potential

(a) **Basin Plan Table 3-20 and 3-21 Parameters.** As described in Section IV.C.2.b of this Fact Sheet, the Basin Plan contains numeric water quality objectives for the Mojave River for chloride, sulfate, fluoride, boron, nitrate, and total dissolved solids. The table below summarizes the reasonable potential analysis for these pollutants. The table includes the maximum concentration of each parameter present in the Discharger’s effluent and the most stringent applicable recommended water quality criterion, objective, or goal along with the basis of that criterion, objective, or goal. As shown in the table below, the discharge does not exhibit reasonable potential for the parameters in Basin Plan Tables 3-20 and 3-21, except

for fluoride (see discussion in section IV.C.3.d(b) of this Fact Sheet for fluoride reasonable potential determination). This Order includes numeric receiving water limitations for boron, chloride, fluoride, nitrate, sulfate, and total dissolved solids based on the Basin Plan objectives, which must be met at the points of discharge from the Facility. This Order also requires monitoring for these parameters.

Table F-10. Summary of Reasonable Potential Analysis for Basin Plan Table 3-20 and 3-21 Parameters

Parameter	Maximum Observed Effluent Concentration (mg/L)	Most Stringent Applicable Recommended Water Quality Criterion or Goal (mg/L)	Basis for Minimum Applicable Water Quality Criterion or Goal	Reasonable Potential?
Boron	ND (0.1)	0.2 (annual average) 0.3 (90 th percentile)	Basin Plan Objective – Mojave River at Victorville	No
Chloride	18	75 (annual average) 100 (90 th percentile)	Basin Plan Objective – Mojave River at Victorville	No
Fluoride	0.37	0.2 (annual average) 1.5 (90 th percentile)	Basin Plan Objective – Mojave River at Victorville	Yes
Nitrate as NO ₃	4.2	5 (instantaneous maximum)	Basin Plan Objective – Mojave River at Lower Narrows	No
Sulfate (SO ₄)	15	40 (annual average) 100 (90 th percentile)	Basin Plan Objective – Mojave River at Victorville	No
Total Dissolved Solids (TDS)	170	312 (instantaneous maximum)	Basin Plan Objective – Mojave River at Lower Narrows	No

- (b) **Acetic Acid, Carbon Dioxide and Sodium Bicarbonate.** The Discharger does not currently use acetic acid at the Facility but may use it in the future for the control of external parasites as flush and/or bath treatments. Carbon dioxide gas may be used in bath treatments to anesthetize fish prior to spawning. Sodium bicarbonate, or baking soda, may also be used in bath treatments as a means of introducing carbon dioxide into the water to anesthetize fish. While the discharge of acetic acid, carbon dioxide, or sodium bicarbonate may affect the pH of the receiving water, current effluent and receiving water limitations for pH are adequate to ensure that any potential discharges of acetic acid, carbon dioxide, or sodium bicarbonate do not impact water quality (in addition, carbon dioxide gas added to water will quickly equilibrate with atmospheric carbon dioxide with aeration). However, the use of these substances must be reported as specified in the Monitoring and Reporting Program (Attachment E).
- (c) **Amoxicillin, Erythromycin, Florfenicol, and Romet-30®.** Amoxicillin, erythromycin, florfenicol, and Romet-30® may be used by CAAP facilities. Amoxicillin is injected into fish to control acute disease outbreaks through a veterinarian's prescription for extra-label use. Erythromycin (injected or used in feed formulations) and florfenicol (used in feed formulations) are antibiotics used to control acute disease outbreaks. Erythromycin must be used under an INAD exemption or a veterinarian feed directive. Florfenicol is a NADA approved drug. Romet-30®, also known by the trade name Sulfadimethoxine-oremtroprim, is an antibiotic used in feed formulations and is FDA-approved for use in aquaculture for control of furunculosis in

salmonids. Amoxicillin (when injected into fish), erythromycin (when injected into fish or used as a feed additive), florfenicol and Romet-30® (when used as feed additives) are used in a manner that reduces the likelihood of direct discharge of antibiotics to waters of the United States or waters of the State, particularly when CAAP facilities implement BMPs as required by this Order. Accordingly, this Order does not include WQBELs for these substances; however, this Order does require reporting of these substances as specified in the attached Monitoring and Reporting Program (Attachment E).

- (d) **Chloramine-T.** Chloramine-T (sodium p-toluenesulfonchloramide), also known by the brand name HALAMID® Aqua, is approved through FDA's NADA program as a replacement for copper sulfate and formalin. Chloramine-T is not currently used but may be used by the Discharger in the future as a possible replacement for formalin. The Discharger reports Chloramine-T may be used as a flush or bath treatment at a concentration of up to 20 mg/L for 1 hour. Chloramine-T breaks down into para-toluene sulfonamide (p-TSA) and, unlike other chlorine-based disinfectants, does not break down into chlorine or form harmful chlorinated compounds.

Results of the Discharger's Pesticide Unit *C. dubia* test where the test animals were exposed to the toxicant for 2 hours followed by three exchanges of control water to remove residual compound and then observed for 96 hours determined the NOEC and LOEC to be 86.3 mg/L and 187 mg/L, respectively.

Effluent data for Chloramine-T are not available to assess the impact of Chloramine-T use at the Facility. Therefore, the following information and calculations were used to estimate the effluent Chloramine-T concentrations from flush treatments at Discharge Points 001 and 002. The calculations assume the flow from the raceways mixes completely with the volume of water in the settling basin and is discharged with no further concentration, breakdown, or dilution of Chloramine-T.

With a flow of 1.83 cfs, the dilution volume of water from one rearing raceway after 1 hour is 49,282 gallons (1 cfs = 26,930 gallons per hour).

The Facility has two settling ponds, each pond having a surface area of 18,200 square feet and a depth that tapers from 12 feet to 16 feet. The volume of each settling pond at 18,200 square feet x 14 feet (average between 12 and 16 feet) is 254,800 cubic feet, or 1,906,036 gallons (1 cubic foot = 7.48052 gallons).

The total dilution volume from the six raceways during 1 hour of flow, plus the volume of the two settling ponds, is 4,107,764 gallons [(49,282 gallons x 6 raceways) + (1,906,036 gallons x 2 settling ponds)].

Flow and volume calculations use the total dilution volume of a 1-hour treatment at 4,107,764 gallons, or 15,549,579 liters (1 gallon = 3.7854118 liters). The Discharger has specified to the Lahontan Water Board that the maximum number of raceways treated per day with Chloramine-T will be two.

Total mass of Chloramine-T applied in milligrams = (# raceways treated) x (treatment time in hours) x (raceway flow in cfs) x (26,930 gallons/hour) x (3.7854118 liters/gallon) x (Chloramine-T concentration in mg/L). The

estimated final effluent concentration of Chloramine-T at Discharge Points 001 and 002 is 0.24 mg/L if one raceway is treated and 0.48 mg/L if two raceways are treated.

Based on available information regarding Chloramine-T if used at the Facility according to the reported treatment, Chloramine-T will not be discharged at levels that cause, have the reasonable potential to cause, or will contribute to an excursion of Basin Plan narrative water quality objectives for toxicity. Accordingly, this Order does not include WQBELs for Chloramine-T. However, use and monitoring of Chloramine-T must be reported as specified in the attached Monitoring and Reporting Program (Attachment E). The Lahontan Water Board will review this information, and other information as it becomes available, and this Order may be reopened to establish effluent limitations based on additional use and toxicity information.

- (e) **Chloride and Electrical Conductivity.** Sodium chloride (salt) is used as needed at CAAP facilities as a fish cleansing agent to control parasites, fish disease, and as an osmoregulatory aid to reduce stress amongst the confined fish population. As discussed above, the Basin Plan contains numeric water quality objectives for chloride for the Mojave River (at Victorville). In addition, the Basin Plan contains a narrative objective for chemical constituents that states, "*Waters designated as AGR shall not contain concentrations of chemical constituents in amounts that adversely affect the water for beneficial uses (i.e., agricultural purposes).*" Water Quality for Agriculture, Food and Agriculture Organization of the United Nations-Irrigation and Drainage Paper No. 29, Rev. 1 (R.S. Ayers and D.W. Westcot, Rome, 1985), recommends that the conductivity level in waters used for agricultural irrigation not exceed 700 $\mu\text{mhos/cm}$ (Agricultural Water Quality Goal) because it will reduce crop yield for sensitive plants. There are no USEPA water quality criteria for the protection of aquatic organisms for electrical conductivity. Based on influent and effluent electrical conductivity monitoring, the discharge of sodium chloride from the Facility will not cause, have a reasonable potential to cause, or contribute to an in-stream excursion of applicable water quality criteria or objectives. This Order requires monitoring for chloride, electrical conductivity, and total dissolved solids and monthly reporting on the use of sodium chloride as specified in the Monitoring and Reporting Program (Attachment E).
- (f) **Chorulon®.** Chorulon® may be used by CAAP facilities. Chorulon® is injected into fish to aid in improving spawning function and is a NADA approved drug. Chorulon® (when injected into fish) is used in a manner that reduces the likelihood of direct discharge of this substance to waters of the United States or waters of the State, particularly when CAAP facilities implement BMPs as required by this Order. Accordingly, this Order does not include WQBELs for Chorulon®; however, this Order does require reporting of Chorulon® as specified in the attached Monitoring and Reporting Program (Attachment E).
- (g) **Epsom salt.** Epsom salt may be used by CAAP facilities. Epsom salt is used in medicated feed or fish pills to control internal parasites. Epsom salt (when used as a medicated feed or fish pills) is used in a manner that reduces the likelihood of direct discharge of this substance to waters of the

United States or waters of the State, particularly when CAAP facilities implement BMPs as required by this Order. Accordingly, this Order does not include WQBELs for Epsom salt; however, this Order does require reporting of Epsom salt as specified in the attached Monitoring and Reporting Program (Attachment E).

- (h) **Ivermectin.** Ivermectin may be used by CAAP facilities. Ivermectin is injected into fish to control parasites. Ivermectin (when injected into fish) is used in a manner that reduces the likelihood of direct discharge of this substance to waters of the United States or waters of the State, particularly when CAAP facilities implement BMPs as required by this Order. Accordingly, this Order does not include WQBELs for Ivermectin; however, this Order does require reporting of Ivermectin as specified in the attached Monitoring and Reporting Program (Attachment E).
- (i) **MS-222®.** CAAP facilities use the anesthetic Tricaine methanesulfonate, commonly known as MS-222 (with trade names of Finquel® or Tricaine-S®). MS-222 has been approved by FDA for use as an anesthetic for *Salmonidae*. Results of toxicity tests using *C. dubia* where the test animals were exposed to MS-222 for 2 hours, followed by three exchanges of control water to remove residual compound and then observed for 96 hours, determined the NOEC and Lowest Observed Effect Concentration (LOEC) to be 70 and 200 mg/L, respectively. MS-222 is generally used as a static treatment bath. The concentration is diluted well below 70 mg/L when discharged at CAAP facilities. Based on available information regarding MS-222 when used according to the reported treatment, MS-222 is not discharged at levels that cause, have the reasonable potential to cause, or will contribute to an excursion of Basin Plan narrative water quality objectives for toxicity. Accordingly, this Order does not include WQBELs for MS-222. However, use of MS-222 must be reported as specified in the attached Monitoring and Reporting Program (Attachment E).
- (j) **Orthophosphate.** The Basin Plan does not contain numeric water quality objectives for the Mojave River for phosphorus, but does contain a narrative objective for biostimulatory substances that states, "*Waters shall not contain biostimulatory substances in concentrations that promote aquatic growths to the extent that such growths cause nuisance or adversely affect the water for beneficial uses.*" Prior to adoption of Order No. R6V-2011-0081, the Lahontan Water Board received complaints regarding nuisance algae and observed algae in waters affected by the Facility's discharge. Phosphorus (primarily orthophosphate) and nitrogen in surface waters are considered biostimulatory substances that may contribute to increase aquatic growths. Order No. R6V-2011-0081 required the Discharger to monitor for total orthophosphate in the influent and effluent to determine if Facility operations are contributing biostimulatory substances. Effluent orthophosphate ranged from 0.012 mg/L to 0.57 mg/L based on 19 samples collected between November 2011 and December 2015. The Facility operations do not add orthophosphate to the water. The Lahontan Water Board finds that orthophosphate does not exhibit reasonable potential to cause or contribute to an exceedance of water quality objectives for

orthophosphate. Therefore, effluent monitoring for orthophosphate has not been retained in this Order.

- (k) **Ovaplant®.** Ovaplant® may be used by CAAP facilities. Ovaplant® is injected into fish to induce gamete maturation and may be used under an INAD exemption. Ovaplant® (when injected into fish) is used in a manner that reduces the likelihood of direct discharge of this substance to waters of the United States or waters of the State, particularly when CAAP facilities implement BMPs as required by this Order. Accordingly, this Order does not include WQBELs for Ovaplant®; however, this Order does require reporting of Ovaplant® as specified in the attached Monitoring and Reporting Program (Attachment E).
- (l) **Oxytetracycline Dihydrate and Oxytetracycline Hydrochloride.** Oxytetracycline dihydrate and oxytetracycline hydrochloride, also known by the brand names Terramycin 200® and Terramycin®, are antibiotics approved through FDA's NADA program for use in controlling ulcer disease, furunculosis, bacterial hemorrhagic septicemia, and pseudomonas disease in salmonids. CAAP facilities use the antibiotics during disease outbreaks. Oxytetracycline dihydrate and oxytetracycline hydrochloride are most commonly used at CAAP facilities as feed additives. However, oxytetracycline hydrochloride may also be used as an extra-label use under a veterinarian's prescription in an immersion bath of approximately 6 to 8 hours in duration. Because oxytetracycline hydrochloride may be applied in an immersion bath for up to 8 hours at a time, the Lahontan Water Board considered the results of acute and chronic aquatic life toxicity testing conducted by the Discharger's Pesticide Unit when determining whether WQBELs for oxytetracycline hydrochloride used in an immersion bath treatment were necessary. Results of acute toxicity tests using *C. dubia* showed a 96-hour No Observed Adverse Effects Level (NOAEL) of 40.4 mg/L. Results of chronic toxicity tests using *C. dubia* showed a 7-day No Observed Effects Concentration (NOEC) for reproduction of 48 mg/L.

The information available regarding use and discharge of oxytetracycline hydrochloride at CAAP facilities indicates that it is discharged at levels well below the lowest NOEC and NOAEL. The Lahontan Water Board determined that oxytetracycline dihydrate, when used in feed, and oxytetracycline hydrochloride, when used in feed or in an immersion bath treatment, is not discharged at levels that cause, have the reasonable potential to cause, or contribute to an excursion of a narrative water quality objective for toxicity from the Basin Plan. Accordingly, this Order does not include effluent limitations for oxytetracycline dihydrate or oxytetracycline hydrochloride. However, the use of oxytetracycline dihydrate and oxytetracycline hydrochloride must be reported as specified in the attached Monitoring and Reporting Program (Attachment E). When used as an immersion bath, the estimated effluent concentrations of oxytetracycline hydrochloride must be reported as specified in the attached Monitoring and Reporting Program (Attachment E). The Lahontan Water Board will review this information, and other information as it becomes available and this Order may be reopened to establish effluent limitations based on additional use and toxicity information.

- (m) **Penicillin-G.** Penicillin G is an antibiotic used for the control of bacterial infections and is administered as a 6 to 8-hour immersion bath treatment. Penicillin G is not approved under FDA's NADA program and its extra-label use in aquaculture requires a veterinarian's prescription. Due to the length of treatment time, the Lahontan Water Board considered the results of acute and chronic aquatic life toxicity testing conducted by the Discharger's Pesticide Unit when determining whether WQBELs for Penicillin G were necessary in this Order. Results of acute toxicity tests using *C. dubia* showed a 96-hour NOAEL of 890 mg/L. Results of 7-day chronic toxicity testing using *Pimephales promelas* showed 7-day NOEC for survival of 350 mg/L. Based on the information available Penicillin G is discharged at levels well below the lowest NOEC and NOAEL at CAAP facilities. Therefore, the Lahontan Water Board determined that Penicillin G, when used in an immersion bath treatment, is not discharged at levels that cause, have the reasonable potential to cause, or contribute to an excursion of a narrative water quality objective for toxicity from the Basin Plan. Accordingly, this Order does not include effluent limitations for Penicillin G. However, the use and estimated effluent concentrations of Penicillin G must be reported as specified in the attached Monitoring and Reporting Program (Attachment E). The Lahontan Water Board will review this information, and other information as it becomes available and this Order may be reopened to establish effluent limitations based on additional use and toxicity information.
- (n) **PVP Iodine.** PVP Iodine (Argentyne), is a solution composed of 10% PVP Iodine Complex and 90% inert ingredients. The FDA considers PVP Iodine an LRP drug for use in aquaculture. PVP Iodine is not currently used but may be used by the Discharger in the future as an egg disinfectant and fungicide. Because PVP Iodine typically is applied in short-term treatments of 1 hour or less, results of acute aquatic life toxicity testing conducted by the Discharger's Pesticide Unit were considered when determining whether WQBELs for PVP Iodine are necessary in this Order. Results of a single acute toxicity test with *C. dubia* showed a 96-hour NOAEL of 0.86 mg/L. This Order does not include WQBELs for PVP Iodine. However, use and monitoring of PVP Iodine must be reported as specified in the attached Monitoring and Reporting Program (Attachment E). The Lahontan Water Board will review this information, and other information as it becomes available, and this Order may be reopened to establish effluent limitations based on additional use and toxicity information.
- (o) **SLICE.** The drug SLICE (Emamectin benzoate 0.2% Aquaculture premix) may be used by CAAP facilities to treat *Salmincola californiensis* (copepods) in finfish. SLICE must be used under an INAD exemption. SLICE is used in a manner that reduces the likelihood of direct discharge to waters of the United States or waters of the State, particularly when CAAP facilities implement BMPs as required by this Order. Medicated feed is prepared by coating SLICE Premix onto the surface of non-medicated fish feed pellets. Feeding occurs to ensure the food is consumed and then metabolized by the fish. This Order does not include WQBELs for SLICE; however, this Order requires reporting of this substance as specified in the attached Monitoring and Reporting Program.

- (p) **Vibrio Vaccine and Enteric Redmouth Bacterin.** The Discharger has not used Vibrio vaccine or enteric redmouth bacterin but use may be required in the future to treat enteric redmouth disease. Enteric redmouth (or yersiniosis) bacterins are formulated from inactivated *Yersinia ruckeri* bacteria and are used as an immersion to help protect salmonid species from enteric redmouth disease caused by *Yersinia ruckeri*. These bacterins stimulate the fish's immune system to produce protective antibodies. Vibrio vaccine is used as an immersion and helps protect salmonid species from vibriosis disease caused by *Vibrio anguillarum* serotype I and *Vibrio ordalii*. Vibrio vaccine stimulates the fish's immune system to produce protective antibodies, helping the animal defend itself against vibriosis.

Vibrio vaccine and enteric redmouth bacterin are licensed for use by the U.S. Department of Agriculture's (USDA's) Center for Veterinary Biologics. According to USDA, most biologics leave no chemical residues in animals and most disease organisms do not develop resistance to the immune response by a veterinary biologic. Based upon available information regarding the use of these substances at CAAP facilities, the Lahontan Water Board does not believe that vibrio vaccine or enteric redmouth bacterins, when used according to label and veterinarian instructions, are discharged at levels that cause, have the reasonable potential to cause, or contribute to an excursion of Basin Plan narrative water quality objectives for toxicity. Accordingly, this Order does not include WQBELs for these substances; however, use of these substances must be reported as specified in the attached Monitoring and Reporting Program (Attachment E).

ii. **Constituents with Reasonable Potential**

- (a) **Fluoride.** As discussed in section IV.C.3.c.i of this Fact Sheet, the MEC for fluoride was 0.37 mg/L based on 13 samples collected between November 2011 and December 2015, which exceeds the applicable Basin Plan objective from Table 3-21 of 0.2 mg/L. Upstream receiving water concentrations in the Mojave River ranged from 0.16 mg/L to 5.5 mg/L based on 28 samples collected between July 2001 and May 2013. The Mojave River in the vicinity of the discharges from the Facility is listed as impaired for fluoride. Based on the effluent fluoride concentrations, the Lahontan Water Board finds that the discharge has reasonable potential to cause or contribute to an exceedance of the water quality objective and effluent limitations are required. As discussed further in section IV.C.4 of this Fact Sheet, this Order includes effluent limitations for fluoride that allow for intake credits.
- (b) **Formaldehyde (Formalin).** Formalin, a solution typically 37 percent by weight formaldehyde, (also known by the trade names Formalin-F®, Paracide-F®, PARASITE-S®) is FDA approved for use in CAAP facilities for controlling external protozoa and monogenetic trematodes on fish, and for controlling fungi of the family *Saprolegniaceae* in food-producing aquatic species. Formalin is used as a treatment for controlling external parasites in raceways where it would be discharged to surface waters. Formalin treatments are usually utilized as a batch or flush treatment which result in discharges from 3 to 8 hours. For control of other fungi, formalin may be

used under an INAD exemption. Formalin can also be used as a "drip" treatment to control fungus on fish eggs.

The Discharger uses formalin at the Facility at a rate of up to 16 gallons per raceway to control external parasites. Effluent formaldehyde data are not available to assess the impact of formalin use at the Facility. Therefore, the following information and calculations were used to determine the estimated effluent formaldehyde concentration from flush treatments at Discharge Points 001 and 002. The calculations assume the flow from the raceways mixes completely with the volume of water in the settling basin and is discharged with no further concentration, breakdown, or dilution of formaldehyde.

The dimensions of each raceway are 1,000 feet long x 10 feet wide x 3 feet deep. Based on these dimensions, the volume of each raceway is 30,000 cubic feet. With a flow of 1.83 cfs, the estimated hydraulic retention time is approximately 4.55 hours (30,000 cubic feet / 1.83 cfs = 1,393 seconds = 4.55 hours). The dilution volume of water from one rearing raceway after 4.55 hours is 224,233 gallons (1 cfs = 26,930 gallons per hour).

The Facility has two settling ponds, each pond having a surface area of 18,200 square feet and a depth that tapers from 12 feet to 16 feet. The volume of each settling pond at 18,200 square feet x 14 feet (average between 12 and 16 feet) is 254,800 cubic feet, or 1,006,036 gallons (1 cubic foot = 7.48052 gallons).

The total dilution volume from the six raceways during 4.55 hours of flow, plus the volume of the two settling ponds, is 5,157,469 gallons [(224,233 gallons x 6 raceways) + (1,906,036 gallons x 2 settling ponds)].

Flow and volume estimates use the total dilution volume from 4.55 hours of flow at 5,157,469 gallons, or 19,523,142 liters. Estimated final effluent concentration of formaldehyde (in mg/L) = [(Total gallons formalin applied) x (3.7854118 liters/gallon) x (370,000 mg formaldehyde / liter formalin)] / (Total dilution volume in liters). The estimated final effluent concentration of formaldehyde at Discharge Points 001 and 002 is 1.15 mg/L if one raceway is treated (16 gallons) and 6.89 mg/L if all six raceways are treated (96 gallons).

The State Water Board, Division of Drinking Water (DDW) does not have a maximum contaminant level (MCL) for formaldehyde; however, the historic DDW Drinking Water Action Level is listed as 0.1 mg/L based on calculation by standard risk assessment methods, with a Modifying Factor equal to 10. The USEPA Integrated Risk Information System (IRIS) lists a reference dose of 1.4 mg/L as a drinking water level. There are no recommended criteria for formaldehyde for the protection of aquatic life.

The Discharger's Pesticide Unit conducted biotoxicity studies to determine the aquatic toxicity of formalin using *Pimephales promelas* and *C. dubia*. A summary of the data submitted follows:

Table F-11. Aquatic Toxicity of Formalin¹

Species	7-day LC50 (mg/L)	LOEC (mg/L)	NOEC (mg/L)	LOAEL (mg/L)	NOAEL (mg/L)
<i>Ceriodaphnia dubia</i>	2.43	5.8 ² 1.3 ³	1.3 ² <1.3 ³	5.8	1.3
<i>Pimephales promelas</i>	23.3	9.09	2.28	--	--
<i>Selanastrum capricornutum</i>	<5.2	--	--	--	--

¹ From the Discharger's laboratory report no. P-2251.1 dated June 30, 2001. Results as formaldehyde. Divide by 0.37 to obtain the equivalent formalin concentration.

² Survival

³ Reproduction

Since formalin treatments are usually utilized as a batch or flush treatment which result in discharges from 3 to 8 hours, short-term tests were conducted with *C. dubia*, exposing the organisms for 2-hour and 8-hour periods, removing them from the chemical, and continuing the observation period for 7 days in clean water. The results were as follows:

Table F-12. Short-Term Aquatic Toxicity of Formalin¹

Species	7-day LC50 (mg/L)	LOAEL (mg/L)	NOAEL (mg/L)
<i>Ceriodaphnia dubia</i> – 2-hour exposure	73.65	46.3	20.7
<i>Ceriodaphnia dubia</i> – 8-hour exposure	13.99	15.3	6.7

¹ From the Discharger's laboratory report no. P-2294.1 dated June 30, 2001. Results as formaldehyde. Divide by 0.37 to obtain the equivalent formalin concentration.

Results of both acute and chronic aquatic life toxicity testing conducted by the Discharger's Pesticide Unit and the Basin Plan narrative toxicity objective were considered when determining whether WQBELs for formalin as formaldehyde were necessary. Results of 7-day chronic toxicity tests indicated *C. dubia* was the most sensitive species, with a 7-day NOEC value of 1.3 mg/L formaldehyde for survival and less than 1.3 mg/L for reproduction (the Lahontan Water Board used an NOEC of 1.3 mg/L). Acute toxicity tests conducted using *C. dubia* showed a 96-hour NOAEL of 1.3 mg/L formaldehyde. The additional acute toxicity tests with *C. dubia*, conducted using only an 8-hour exposure, resulted in a 96-hour NOAEL concentration of 6.7 mg/L formaldehyde.

The Lahontan Water Board has determined that if formalin is used, formaldehyde may be discharged at levels that cause, have the reasonable potential to cause, or contribute to an excursion of the Basin Plan narrative water quality objective. Accordingly, this Order includes WQBELs for formaldehyde. Although formaldehyde treatments are short in duration, exposure to formaldehyde in the receiving water as a result of discharges from the Facility may be long-term because of retention time in the settling pond, recirculation flow back to the raceways, and potential application procedures (e.g., successive raceway treatments, drip treatments for eggs). Therefore, an AMEL of 0.65 mg/L and an MDEL of 1.3 mg/L are calculated based on the 96-hour NOAEL value and using the procedure in USEPA's March 1991 *Technical Support Document for Water Quality-based Toxics Control* (EPA/505/2-90-001) (TSD) for calculating WQBELs as described in the Section IV.C.4 of this Fact Sheet. These effluent limitations are carried over from Order R6V-2011-0081. Use and

monitoring of formaldehyde must be reported as specified in the attached Monitoring and Reporting Program (Attachment E).

- (c) **Hydrogen Peroxide.** Hydrogen peroxide (35% H₂O₂) is used at the Facility for the control of external parasites as a raceway flush treatment at a concentration of 100 mg/L or less, from 45 minutes to 1 hour. FDA approved hydrogen peroxide to control fungi on fish at all life stages, including eggs. Hydrogen peroxide may also be used to control bacterial gill disease in salmonids, and, through an INAD, external parasites. Hydrogen peroxide is a strong oxidizer that rapidly breaks down into water and oxygen; however, it exhibits toxicity to aquatic life during the oxidation process.

The Lahontan Water Board considered the results of acute aquatic life toxicity testing conducted by the Discharger's Pesticide Unit when determining whether WQBELs for hydrogen peroxide were necessary in this Order. Results of an acute toxicity test using *C. dubia* showed a 96-hour NOAEL of 1.3 mg/L based on continual constant exposure to hydrogen peroxide. When exposed to hydrogen peroxide for 2 hours followed by a triple lab water flush and normal test completion, *C. dubia* showed a 96-hour NOEC of 2 mg/L.

Effluent hydrogen peroxide data are not available to assess the impact of hydrogen peroxide use at the Facility. Therefore, the following information and calculations were used to determine the estimated effluent hydrogen peroxide concentration from flush treatments at Discharge Points 001 and 002. The calculations assume the flow from the raceways mixes completely with the volume of water in the settling basin and is discharged with no further concentration, breakdown, or dilution of hydrogen peroxide.

With a flow of 1.83 cfs, the dilution volume of water from one rearing raceway after 1 hour is 49,282 gallons (1 cfs = 26,930 gallons per hour).

The Facility has two settling ponds, each pond having a surface area of 18,200 square feet and a depth that tapers from 12 feet to 16 feet. The volume of each settling pond at 18,200 square feet x 14 feet (average between 12 and 16 feet) is 254,800 cubic feet, or 1,906,036 gallons (1 cubic foot = 7.48052 gallons).

The total dilution volume from the six raceways during 1 hour of flow, plus the volume of the two settling ponds, is 4,107,764 gallons [(49,282 gallons x 6 raceways) + (1,906,036 gallons x 2 settling ponds)].

Flow and volume estimates use the total dilution volume from a 1-hour treatment at 4,107,764 gallons, or 15,549,579 liters (1 gallon = 3.7854118 liters).

Total mass of hydrogen peroxide applied in milligrams = (# raceways treated) x (treatment time in hours) x (raceway flow in cfs) x (26,930 gallons/hour) x (3.7854118 liters/gallon) x (hydrogen peroxide concentration in mg/L).

Estimated final effluent concentration of hydrogen peroxide (in mg/L) = Total mass of hydrogen peroxide applied in milligrams / total dilution volume in liters. The results were as follows:

Table F-13. Estimated Effluent Hydrogen Peroxide Concentrations

Number of Raceways Treated with H ₂ O ₂	H ₂ O ₂ (35%) Treatment Conc. (mg/L)	H ₂ O ₂ Treatment Conc. (mg/L)	Treatment Time in hours	Total Mass of H ₂ O ₂ Applied (mg)	Total Dilution Volume in Liters	Estimated Final Effluent H ₂ O ₂
1	100	35	1	6,529,330	15,549,579	0.42
6	100	35	1	39,175,980	15,549,579	2.52

The MEC for hydrogen peroxide was 1.4 mg/L based on five samples collected between November 2011 and February 2016, which exceeds the 96-hour NOAEL value. The Discharger failed to collect samples during hydrogen peroxide use on five other occasions. The Discharger suspects that the sample results of 1.4 mg/L observed in December 2015 and February 2016 are erroneous due to suspected laboratory reliability issues and the nature of hydrogen peroxide, which is highly reactive and degrades rapidly. In the absence of an approved analytical method at 40 C.F.R. part 136, the Discharger has proposed to discontinue off-site laboratory analysis of hydrogen peroxide and to conduct sampling using a Hach® hydrogen peroxide titration kit.

In the absence of reliable sample results for hydrogen peroxide in the effluent, the Lahontan Water Board has determined that, based on available toxicity testing data and the estimated concentrations, hydrogen peroxide may be discharged at levels that cause, have the reasonable potential to cause, or contribute to an excursion of the Basin Plan narrative water quality objective. Accordingly, this Order includes WQBELs for hydrogen peroxide. The actual effluent concentrations are likely to be lower as the calculations assume no breakdown of hydrogen peroxide. Since hydrogen peroxide is a strong oxidizer concentrations are unlikely to persist for long periods. Therefore, a MDEL of 1.3 mg/L is calculated based on the 96-hour NOAEL value and using the procedure in USEPA's TSD for calculating WQBELs as described in the Section IV.C.4 of this Fact Sheet. This effluent limitation is carried over from Order No. R6V-2011-0081. Use and monitoring of hydrogen peroxide must be reported as specified in the attached Monitoring and Reporting Program (Attachment E).

- (d) **Manganese.** The Secondary MCL – Consumer Acceptance Limit for manganese is 50 µg/L, which is incorporated by reference into the Basin Plan chemical constituent objective. The MEC for manganese was 63 µg/L based on six samples collected between November 2011 and December 2015. The effluent result of 63 mg/L was observed during a period of treatment with potassium permanganate, which may be a source of the observed elevated manganese concentration. Therefore, the discharge exhibits reasonable potential to cause or contribute to an exceedance of the applicable water quality objective. This Order establishes an AMEL of 50 µg/L and an MDEL of 100 µg /L based on the Secondary MCL and using the procedure in USEPA's TSD for calculating WQBELs as described in the Section IV.C.4 of this Fact Sheet.
- (e) **pH.** The Basin Plan states: "*In fresh waters with designated beneficial uses of COLD or WARM, changes in ambient pH levels shall not exceed 0.5 pH units. For all other waters of the Region, the pH shall not be*

depressed below 6.5 nor raised above 8.5." To provide protection for the receiving water beneficial uses, discharge limitations are end-of-pipe limits with no allowance for dilution within the receiving water. Also, to provide protection for the receiving water beneficial uses and to meet the receiving water limitations (Basin Plan objectives), this Order retains the effluent limitations for pH established in Order No. R6V-2011-0081.

- (f) **Potassium Permanganate.** Potassium permanganate (also known by the trade name of Cairox™) is used at the Facility to control gill disease, bacteria, and parasites. Potassium permanganate has a low estimated lifetime in the environment, being readily converted by oxidizable materials to insoluble manganese dioxide (MnO₂). In non-reducing and nonacidic environments, MnO₂ is insoluble and has a very low bioaccumulative potential. In addition, potassium permanganate is rapidly converted to insoluble manganese dioxide under hatchery conditions. Potassium permanganate is a special category drug the FDA calls "regulatory action deferred".

Potassium permanganate is used at the Facility as a flush treatment at a rate of 2 ounces per cubic feet per second (cfs) of raceway flow, for a total of three treatments spaced 10 to 15 minutes apart, or used in bath treatments of 2 mg/L or less for 1 hour. The following information and calculations were used to determine the estimated effluent potassium permanganate concentration from flush treatments at Discharge Points 001 and 002. The calculations assume the flow from the raceways mixes completely with the volume of water in the settling basin and is discharged with no further concentration, breakdown, or dilution of potassium permanganate.

The dimensions of each raceway are 1,000 feet long x 10 feet wide x 3 feet deep. Based on these dimensions, the volume of each raceway is 30,000 cubic feet. With a flow of 1.83 cfs, the estimated hydraulic retention time is approximately 4.55 hours (30,000 cubic feet / 1.83 cfs = 1,393 seconds = 4.55 hours). The dilution volume of water from one rearing raceway after 4.55 hours is 224,233 gallons (1 cfs = 26,930 gallons per hour).

The Facility has two settling ponds, each pond having a surface area of 18,200 square feet and a depth that tapers from 12 feet to 16 feet. The volume of each settling pond at 18,200 square feet x 14 feet (average between 12 and 16 feet) is 254,800 cubic feet, or 1,006,036 gallons (1 cubic foot = 7.48052 gallons).

The total dilution volume from the six raceways during 4.55 hours of flow, plus the volume of the two settling ponds, is 5,157,469 gallons [(224,233 gallons x 6 raceways) + (1,906,036 gallons x 2 settling ponds)].

Flow and volume estimates use the total dilution volume from 4.55 hours of flow at 5,157,469 gallons. Estimated final effluent concentration of potassium permanganate (KMnO₄) (in mg/L) = [(# raceways treated) x (3 treatments) x (2 ounces per cfs) x (flow in cfs) x (0.0625 lbs/ounce)] / [(Total dilution in gallons) x (8.34 lbs/gallon)] x 1,000,000. The estimated final effluent concentration of potassium permanganate at Discharge Points 001 and 002 is 0.016 mg/L if one raceway is treated and 0.096 mg/L if six raceways are treated. Actual concentrations are likely to

be lower as the calculations assumed no breakdown of potassium permanganate.

Effluent concentrations could not be estimated from the disposal of bath treatment wastewaters as information regarding volumes and location of disposal (which affects dilution factors) was unavailable. However, effluent potassium permanganate concentrations from the disposal of bath treatments wastewater are likely to be even lower than the concentrations estimated for flush treatments, due to the smaller quantities of wastewater and low concentrations used in bath treatments (2 mg/L).

Results of a single acute toxicity test conducted by the Discharger's Pesticide Unit using *C. dubia* showed a 96-hour NOAEL of 0.038 mg/L for potassium permanganate under continuous exposure. The Discharger's 2-hour exposure test showed a 0.1975 mg/L No Observed Effect Concentration (NOEC). Potassium permanganate was not detected in five samples collected during the term of Order R6V-2011-0081. However, because the estimated effluent concentration of 0.096 mg/L exceeds the 96-hour NOAEL of 0.038 mg/L, the discharge of potassium permanganate at the Facility has the reasonable potential to cause or contribute to an instream excursion of applicable water quality criteria or objectives. Therefore, an AMEL of 0.031 mg/L and an MDEL of 0.062 mg/L have been established based on the 96-hour NOAEL value and using the procedure in USEPA's TSD for calculating WQBELs as described in Section IV.C.4 of this Fact Sheet. Use and monitoring of potassium permanganate must be reported as specified in the attached Monitoring and Reporting Program (Attachment E).

- (g) **Settleable Solids.** The Basin Plan includes a water quality objective for surface waters that "*waters shall not contain substances in concentrations that result in deposition of material that causes nuisance or that adversely affects the water for beneficial uses. For natural high quality waters, the concentration of settleable materials shall not be raised by more than 0.1 milliliter per liter.*" Order No. R6V-2011-0081 contained an effluent limitation for settleable solids of 0.1 ml/L as an AMEL. The Lahontan Water Board has retained the numeric effluent limitation for settleable solids for the Facility in order to prevent an instream excursion above the water quality standard.

4. WQBEL Calculations

a. Pollutants That Did Not Demonstrate Reasonable Potential

WQBELs are not included in this Order for constituents that do not demonstrate reasonable potential or where it was undetermined whether WQBELs were necessary (e.g., where the reported detection levels are higher than the applicable criteria/objectives). However, monitoring during the term of this Order for those pollutants is required in accordance with Section 1.3 of the SIP. If concentrations of these constituents are found to have increased significantly, the Discharger will be required to investigate the sources of the increases. Remedial measures are required if the increases pose a threat to receiving water quality.

b. Pollutants with Reasonable Potential

This Order includes WQBELs for fluoride, formaldehyde, hydrogen peroxide, manganese, pH, potassium permanganate, and settleable solids at Discharge

Points 001 and 002. WQBELs were developed for the pollutants determined to have reasonable potential to cause or contribute to exceedances of the water quality objectives. The WQBELs for fluoride, formaldehyde, hydrogen peroxide, manganese, and potassium permanganate were calculated based on water quality objectives and the procedures described below. For WQBELs based on Basin Plan objectives (i.e., pH and settleable solids), the objectives are applied directly as the effluent limitations.

i. Fluoride

The Discharger does not alter the fish hatchery wastewater (i.e., groundwater) that is eventually discharged at Discharge Points 001 and 002 with respect to fluoride. If the groundwater was not withdrawn by the Facility, it would naturally reach the Mojave River as there is a hydrological connection between the aquifer and surface water. Therefore, the Lahontan Water Board believes that intake water credits are applicable and appropriate for the discharge from the Facility.

- (a) **SIP Intake Water Credit Requirements.** SIP section 1.4.4 provides for intake water credits under specific circumstances. When met, a discharger may discharge a mass or concentration of a pollutant that is no greater than the mass or concentration found in its intake water (e.g., the discharger may add a mass of the pollutant to its waste stream if it also removes an equal or greater mass prior to discharge, resulting in no net addition of the pollutant). This Order provides intake water credits for fluoride discharges from Discharge Points 001 and 002, which comply with the SIP requirements.

In accordance with Section 1.4.4 of the SIP, the Lahontan Water Board may consider pollutants in intake water on a pollutant-by-pollutant and discharge-by-discharge basis when establishing WQBELs provided that the discharger has demonstrated to the satisfaction of the Lahontan Water Board that five specified conditions are met. The Lahontan Water Board finds that the discharges from the Facility meet the conditions, outlined in the SIP, for intake credits for fluoride, as described below.

Condition 1. The observed maximum ambient background concentration, as determined in section 1.4.3.1 of the SIP, and the intake water concentration of the pollutant exceeds the most stringent applicable criterion/objective for that pollutant.

The applicable Basin Plan objective from Table 3-21 for fluoride is 0.2 mg/L. Upstream receiving water fluoride concentrations in the Mojave River ranged from 0.16 mg/L to 5.5 mg/L based on 28 samples collected between July 2001 and May 2013. The Mojave River in the vicinity of the discharges from the Facility is listed as impaired for fluoride. Influent fluoride concentrations ranged from 0.24 mg/L to 0.37 mg/L based on 13 samples collected between November 2011 and December 2015. Based on upstream receiving water and influent data, this condition is met because the observed maximum ambient background and intake water fluoride concentration exceeds the most stringent water quality criterion/objective.

Condition 2. *The intake water credits provided are consistent with any TMDL applicable to the discharge that has been approved by the Regional Water Board, State Water Board, and USEPA.*

The Mojave River is listed on the CWA Section 303(d) List of Water Quality Limited Segments requiring TMDLs; however, the proposed TMDL for fluoride is not scheduled for completion until 2021. Fluoride in the Mojave River is known to originate from natural sources.

Condition 3. *The intake water is from the same water body as the receiving water body. The discharger may demonstrate this condition by showing that:*

- a) the ambient background concentration of the pollutant in the receiving water, excluding any amount of the pollutant in the facility's discharge, is similar to that of the intake water;*
- b) there is a direct hydrological connection between the intake and discharge points;*
- c) the water quality characteristics are similar in the intake and receiving waters; and*
- d) the intake water pollutant would have reached the vicinity of the discharge point in the receiving water within a reasonable period of time and with the same effect had it not been diverted by the discharger.*

This condition is met because there is a direct hydrological connection between the groundwater (intake water source) and the receiving water (the Mojave River) and because the intake water fluoride would have reached the vicinity of the discharge point in the receiving water had it not been diverted by the Discharger.

The Mojave River Fish Hatchery overlies the Upper Mojave Valley Groundwater Basin as identified in Department of Water Resources (DWR) Bulletin 118. The Upper Mojave Valley Groundwater Basin is composed of two aquifers: the shallow "floodplain" or shallow water table aquifer, and the deeper "regional" aquifer. The intake water is from the deeper regional aquifer. The floodplain aquifer is generally composed of river channel deposits and flood plain deposits and follows the course of the Mojave River. The regional aquifer is composed of unconsolidated (generally) alluvium, lake, and playa deposits and is aerially more extensive. The floodplain aquifer is more permeable and the primary water supply source for the basin. The two aquifers are unconfined and hydraulically connected. Both the floodplain and the regional aquifers directly contribute to base flow of the Mojave River and are recharged by the Mojave River. The floodplain aquifer is in direct communication with the river wherever the aquifer is present. The regional aquifer is in direct contact with the river where subsurface features create a condition where the river and the deeper aquifer are in direct communication. During high flow periods the river is a "losing stream" and replenishes the groundwater aquifer. During low flow periods, the river is a "gaining stream" and is fed by the underlying aquifers. Consequently, the intake water would have reached the receiving water without the effluent discharge to the Mojave River. [Lines, Gregory C., 1996 Ground-water and Surface-water

Relations along the Mojave River, Southern California: U.S. Geological Survey Water-Resources Investigations Report 95-4189]

Condition 4. The facility does not alter the intake water pollutant chemically or physically in a manner that adversely affects water quality and beneficial uses.

The Discharger does not alter the fish hatchery wastewater (i.e., groundwater) that is eventually discharged at Discharge Points 001 and 002 with respect to fluoride by the addition of chemicals or other pollutants.

Condition 5. The timing and location of the discharge does not cause adverse effects on water quality and beneficial uses that would not occur if the intake water pollutant had been left in the receiving water body.

The timing and location of the discharge from the Facility does not cause adverse effects on water quality and beneficial uses that would not occur if the pollutants in the intake water had been left in the intake water body. As shown in the following table, fluoride concentrations are generally lower in the influent and effluent than the upstream receiving water. Additionally, receiving water fluoride concentrations downstream of the Facility are generally lower than upstream concentrations.

Table F-14. Summary of Fluoride Monitoring Data

Monitoring Location	Minimum (mg/L)	Maximum (mg/L)	Average (mg/L)	Number of Data Points
Influent (Monitoring Location M-001)	0.21	0.38	0.30	19
Effluent (Monitoring Location INF-001)	0.24	0.37	0.31	12
Upstream Receiving Water (Mojave River below Forks Reservoir)	0.16	5.5	1.8	28
Downstream Receiving Water (Mojave River at the Upper Narrows)	0.15	1.95	0.43	29

Therefore, the Lahontan Water Board will allow intake water credits for fluoride. This credit is to offset elevated levels of fluoride found in the intake water. As stated in Section 1.4.4 of the SIP, the Lahontan Water Board "may establish effluent limitations allowing the facility to discharge a mass and concentration of the intake water pollutant that is no greater than the mass and concentration in the facility's intake water ... so there is no net addition of the pollutant in the discharge compared to the intake water."

- (b) **Calculation of Intake Water Credits.** To qualify for an intake water credit, the effluent pollutant concentration must be less than or equal to the intake pollutant concentration. However, intake and effluent data collected on the same day may differ due to factors unrelated to Facility operations, such as sampling and laboratory analytical variability. Since the residence time of groundwater from intake to discharge is of relatively short duration, samples taken on the same day should be representative of the same water (assuming the samples are collected within a reasonably short time from each other). As shown in the table below, variability between the influent and effluent occurred throughout the term of Order R6V-2011-0081; there were times when the effluent concentrations were slightly

higher than the influent concentrations, as well as instances when the influent concentrations were higher than effluent concentrations.

Table F-15. Influent and Effluent Fluoride Monitoring Data

Sample Date	Effluent (mg/L)	Influent (mg/L)
November 17, 2011	0.37	0.38
November 17, 2011	--	0.37
February 7, 2012	0.3	0.29
May 15, 2012	0.37	0.38
May 15, 2012	0.33	0.34
September 5, 2012	0.37	0.34
November 15, 2012	--	0.31
February 19, 2013	0.3	0.3
May 8, 2013	0.3	0.3
August 12, 2013	0.29	0.3
November 19, 2013	--	0.3
February 13, 2014	--	0.32
May 7, 2014	0.3	0.3
August 26, 2014	0.32	0.3
November 25, 2014	0.27	0.26
February 27, 2015	0.26	0.24
May 5, 2015	0.24	0.24
August 28, 2015	--	0.21
November 6, 2015	--	0.21

In order to account for the variability among the influent and effluent samples collected by the Discharger, the methodology for developing effluent limitations was revised. Since the residence time of groundwater from intake to discharge is of relatively short duration and the Discharger does not alter the waste stream with respect to fluoride, the Lahontan Water Board has assumed the influent and effluent pollutant concentration are drawn from the same distribution. Thus, the 99th percentile concentration of the available data from both the influent and effluent monitoring locations was calculated. The resulting 99th percentile value represents the upper range of the variability between intake and effluent pollutant concentrations due to sampling and analysis variability. When used as the basis for the effluent limitation, it results in an intake credit that captures the variability between influent and effluent data, and prevents the discharge of additional pollutant mass. A higher percentile might include extreme and possibly false values, which might mask a legitimate violation; a lower percentile might result in violations due to sample variability instead of the addition of pollutants. The calculated 99th percentile concentration for fluoride, which will serve as the final maximum daily effluent limitation (MDEL) that accounts for intake credits, is 0.44 mg/L.

40 C.F.R section 122.45(d) requires, unless impracticable, that effluent limitations for continuous discharges be stated as MDELs and AMELs. The method for deriving effluent limitations that account for pollutant concentrations in the intake to the Facility (i.e., intake credits) is based on a statistically-based upper bound (99th percentile) of the influent and effluent data. As such, this upper bound estimate is used to evaluate whether the Discharger contributes pollutant mass or concentrations

above those levels contained in the influent to the Facility. Therefore, compliance with an MDEL is considered more appropriate for this discharge situation where intake credits are being applied.

ii. Formaldehyde

Effluent limitations for formaldehyde were calculated based on the 96-hour NOAEL value of 1.3 mg/L and using the procedure in USEPA’s TSD assuming the following:

- No in-stream dilution allowance.
- Coefficient of variation (CV) = 0.6 for the lognormal distribution of pollutant concentrations in effluent.

Calculation of Aquatic Life AMEL and MDEL:

Effluent Concentration Allowances (ECA) based on NOAEL (acute toxicity) and NOEC (chronic toxicity) for *C. dubia*, with no dilution allowance:

$ECA_{acute} = 1.3 \text{ mg/L}$
 $ECA_{chronic} = 1.3 \text{ mg/L}$

Long-Term Average concentration based on acute ECA:

$LTA_{acute} = 1.3 \text{ mg/L} \times 0.321 = 0.4173 \text{ mg/L}$ (where 0.321 = acute ECA multiplier at 99% occurrence probability and 99% confidence)

Long-Term Average concentration based on chronic ECA:

$LTA_{chronic} = 1.3 \text{ mg/L} \times 0.527 = 0.685 \text{ mg/L}$ (where 0.527 = chronic ECA multiplier at 99% occurrence probability and 99% confidence)

Most Limiting LTA concentration based on acute LTA:

$LTA = 0.417 \text{ mg/L}$

Average Monthly Effluent Limitation:

$AMEL = LTA \times 1.55$ (where 1.55 = AMEL multiplier at 95% occurrence probability, 99% confidence, and $n = 4$)

$AMEL_{aquatic \text{ life}} = 0.4173 \text{ mg/L} \times 1.55 = 0.65 \text{ mg/L}$

Maximum Daily Effluent Limitation:

$MDEL = LTA \times 3.11$ (where 3.11 = MDEL multiplier at 99% occurrence probability and 99% confidence)

$MDEL_{aquatic \text{ life}} = 0.4173 \text{ mg/L} \times 3.11 = 1.3 \text{ mg/L}$

Calculation of Human Health AMEL and MDEL:

This section is not applicable as the formaldehyde limits are based on aquatic life criteria.

Determination of Final WQBELs:

The lower AMEL and MDEL based on aquatic life and human health is selected as the WQBEL.

$AMEL_{aquatic \text{ life}}$	$MDEL_{aquatic \text{ life}}$	$AMEL_{human \text{ health}}$	$MDEL_{human \text{ health}}$
0.65 mg/L	1.3 mg/L	Not Applicable	Not Applicable

The final AMEL of **0.65 mg/L** and MDEL of **1.3 mg/L** for formaldehyde are based on limitations protective of aquatic life.

iii. Hydrogen Peroxide

As hydrogen peroxide is a strong oxidizer, effluent concentrations are unlikely to persist for long periods. Therefore, only a MDEL was calculated based on the 96-hour NOAEL value for *C. dubia* and using the procedure in USEPA's TSD assuming the following:

- No in-stream dilution allowance.
- CV = 0.6 for the lognormal distribution of pollutant concentrations in effluent.

Effluent Concentration Allowances based on NOAEL with no dilution allowance:

$$ECA_{\text{acute}} = 1.3 \text{ mg/L}$$

No chronic toxicity data, Long-Term Average concentration based on acute ECA:

$$LTA = 1.3 \text{ mg/L} \times 0.321 = 0.4173 \text{ mg/L} \text{ (where } 0.321 = \text{ acute ECA multiplier at } 99\% \text{ occurrence probability and } 99\% \text{ confidence)}$$

Maximum Daily Effluent Limitation:

$$\text{MDEL} = LTA \times 3.11 \text{ (where } 3.11 = \text{ MDEL multiplier at } 99\% \text{ occurrence probability and } 99\% \text{ confidence)}$$

$$\text{MDEL} = 0.4173 \text{ mg/L} \times 3.11 = \mathbf{1.3 \text{ mg/L}}$$

This effluent limitation has been established for protection of aquatic life against toxic effects from exposure to hydrogen peroxide in the discharge.

iv. Manganese

Effluent limitations for manganese were calculated based on the Secondary MCL and using the procedure in USEPA's TSD assuming the following:

- No in-stream dilution allowance.
- CV = 0.6 for the lognormal distribution of pollutant concentrations in effluent.

Calculation of Aquatic Life AMEL and MDEL:

This section is not applicable as the manganese limits are based on human health criteria.

Calculation of Human Health AMEL and MDEL:

ECA based on Secondary MCL with no dilution allowance:

$$ECA_{\text{human health}} = 50 \text{ } \mu\text{g/L}$$

Average Monthly Effluent Limitation:

$$\text{AMEL}_{\text{human health}} = ECA_{\text{human health}} = 50 \text{ } \mu\text{g/L}$$

Maximum Daily Effluent Limitation:

$$\text{MDEL} = ECA_{\text{human health}} \times \text{MDEL/AMEL multiplier}$$

$$\text{MDEL}_{\text{human health}} = 50 \text{ } \mu\text{g/L} \times 2.01 = 100 \text{ } \mu\text{g/L}$$

Determination of Final WQBELs:

The lower AMEL and MDEL based on aquatic life and human health is selected as the WQBEL.

AMEL _{aquatic life}	MDEL _{aquatic life}	AMEL _{human health}	MDEL _{human health}
Not Applicable	Not Applicable	50 µg/L	100 µg/L

The final AMEL of **50 µg/L** and MDEL of **100 µg/L** for manganese are based on limitations protective of human health.

v. Potassium permanganate

Effluent limitations for potassium permanganate were calculated based on the 96-hour NOAEL value of 0.038 mg/L and using the procedure in USEPA’s TSD assuming the following:

- No in-stream dilution allowance.
- Coefficient of variation (CV) = 0.6 for the lognormal distribution of pollutant concentrations in effluent.

Calculation of Aquatic Life AMEL and MDEL:

Effluent Concentration Allowances (ECA) based on NOAEL (chronic toxicity) and NOEC (acute toxicity) for *C. dubia*, with no dilution allowance:

$$ECA_{acute} = 0.1975 \text{ mg/L}$$

$$ECA_{chronic} = 0.038 \text{ mg/L}$$

Long-Term Average concentration based on acute ECA:

$$LTA_{acute} = 0.1975 \text{ mg/L} \times 0.321 = 0.063 \text{ mg/L} \text{ (where } 0.321 = \text{ acute ECA multiplier at 99\% occurrence probability and 99\% confidence)}$$

Long-Term Average concentration based on chronic ECA:

$$LTA_{chronic} = 0.038 \text{ mg/L} \times 0.527 = 0.020 \text{ mg/L} \text{ (where } 0.527 = \text{ chronic ECA multiplier at 99\% occurrence probability and 99\% confidence)}$$

Most Limiting LTA concentration based on acute LTA:

$$LTA = 0.020 \text{ mg/L}$$

Average Monthly Effluent Limitation:

$$AMEL = LTA \times 1.55 \text{ (where } 1.55 = \text{ AMEL multiplier at 95\% occurrence probability, 99\% confidence, and } n = 4)$$

$$AMEL_{aquatic \text{ life}} = 0.020 \text{ mg/L} \times 1.55 = 0.031 \text{ mg/L}$$

Maximum Daily Effluent Limitation:

$$MDEL = LTA \times 3.11 \text{ (where } 3.11 = \text{ MDEL multiplier at 99\% occurrence probability and 99\% confidence)}$$

$$MDEL_{aquatic \text{ life}} = 0.020 \text{ mg/L} \times 3.11 = 0.062 \text{ mg/L}$$

Calculation of Human Health AMEL and MDEL:

This section is not applicable as the potassium permanganate limits are based on aquatic life criteria.

Determination of Final WQBELs:

The lower AMEL and MDEL based on aquatic life and human health is selected as the WQBEL.

AMEL _{aquatic life}	MDEL _{aquatic life}	AMEL _{human health}	MDEL _{human health}
0.031 mg/L	0.062 mg/L	Not Applicable	Not Applicable

The final AMEL of **0.031 mg/L** and MDEL of **0.062 mg/L** for potassium permanganate are based on limitations protective of aquatic life.

5. Whole Effluent Toxicity (WET)

The Basin Plan specifies a narrative objective for toxicity, requiring that "All waters shall be maintained free of toxic substances in concentrations that are toxic to, or that produce detrimental physiological responses in human, plant, animal, or aquatic life." Compliance with this objective will be determined by use of indicator organisms, analyses of species diversity, population density, growth anomalies, bioassays of appropriate duration and/or other appropriate methods as specified by the Lahontan Water Board. The survival of aquatic life in surface waters subjected to a waste discharge, or other controllable water quality factors, shall not be less than that for the same water body in areas unaffected by the waste discharge, or when necessary, for other control water that is consistent with the requirements for "experimental water" as defined in Standard Methods for the Examination of Water and Wastewater (American Public Health Association, et al. 1992).

In addition to the Basin Plan requirements, Section 4 of the SIP states that a chronic toxicity effluent limitation is required in permits for all discharges that will cause, have the reasonable potential to cause, or contribute to chronic toxicity in receiving waters.

Numeric water quality criteria or Basin Plan numeric objectives currently are not available for most of the aquaculture drugs and chemicals used by the Discharger or proposed for use at this facility. Therefore, the Lahontan Water Board used the narrative water quality objective for toxicity from the Basin Plan as a basis for determining "reasonable potential" for discharges of these drugs and chemicals. Due to the nature of operations and chemical treatments at this Facility, its effluent generally contains only one or two known chemicals at any given time. Therefore, the Lahontan Water Board is using a chemical-specific approach to determine "reasonable potential" for discharges of aquaculture drugs and chemicals. As such it is not necessary to include an acute toxicity effluent limitation or require acute or chronic WET testing.

D. Final Effluent Limitation Considerations

1. Mass-based Effluent Limitations

40 C.F.R. section 122.45(f)(1) requires effluent limitations be expressed in terms of mass, with some exceptions, and 40 C.F.R. section 122.45(f)(2) allows pollutants that are limited in terms of mass to additionally be limited in terms of other units of measurement. This Order includes effluent limitations expressed in terms of concentration, as mass limitations are not necessary to protect the beneficial uses of the receiving water.

2. Anti-Backsliding Requirements

Sections 402(o) and 303(d)(4) of the CWA and federal regulations at 40 C.F.R. section 122.44(l) prohibit backsliding in NPDES permits. These anti-backsliding provisions require effluent limitations in a reissued permit to be as stringent as those in the previous permit, with some exceptions where limitations may be relaxed. All effluent limitations in this Order are at least as stringent as the effluent limitations in Order R6V-2011-0081.

3. Antidegradation Policies

Section 131.12 requires that the state water quality standards include an anti-degradation policy consistent with the federal policy. The State Water Board established California’s antidegradation policy in State Water Board Resolution No. 68-16. Resolution No. 68-16 incorporates the federal antidegradation policy where the federal policy applies under federal law. Resolution No. 68-16 requires that existing water quality be maintained unless degradation is justified based on specific findings. The Lahontan Water Board’s Basin Plan implements, and incorporates by reference, both the State and federal antidegradation policies.

This Order does not provide for an increase in the permitted design flow or allow for an increase in mass or concentration of any pollutant. Therefore, the issuance of this permit is consistent with the State’s antidegradation policy.

4. Stringency of Requirements for Individual Pollutants

This Order contains both technology-based effluent limitations and WQBELs for individual pollutants. The technology-based effluent limitations consist of restrictions on TSS from Discharge Points 001 and 002. Restrictions on TSS are discussed in section IV.B of this Fact Sheet. This Order’s technology-based pollutant restrictions implement the minimum, applicable federal technology-based requirements.

This Order includes WQBELs for fluoride, formaldehyde, hydrogen peroxide, manganese, pH, potassium permanganate, and settleable solids at Discharge Points 001 and 002. WQBELs have been scientifically derived to implement water quality objectives that protect beneficial uses. Both the beneficial uses and the water quality objectives have been approved pursuant to federal law and are the applicable federal water quality standards. The scientific procedures for calculating the WQBELs for priority pollutants are based on the CTR-SIP, which was approved by USEPA on May 18, 2000. All beneficial uses and water quality objectives contained in the Basin Plan were approved under state law and submitted to and approved by USEPA prior to May 30, 2000. Collectively, this Order’s restrictions on individual pollutants are no more stringent than required to implement the requirements of the CWA.

**Summary of Water Quality-Based Effluent Limitations
 Discharge Points 001 and 002**

Table F-16. Summary of Water Quality-Based Effluent Limitations

Parameter	Units	Effluent Limitations			
		Average Monthly	Maximum Daily	Instantaneous Minimum	Instantaneous Maximum
pH	standard units	--	--	6.5	8.5
Fluoride, Total	mg/L	--	0.44	--	--
Manganese, Total Recoverable	µg/L	50	100	--	--
Formaldehyde	mg/L	0.65	1.3	--	--
Hydrogen Peroxide	mg/L	--	1.3	--	--
Potassium Permanganate	mg/L	0.031	0.062	--	--
Settleable Solids	mL/L	0.1	--	--	--

E. Interim Effluent Limitations – Not Applicable

F. Land Discharge Specifications – Not Applicable

G. Recycling Specifications – Not Applicable

V. RATIONALE FOR RECEIVING WATER LIMITATIONS

The receiving water limitations in this Order are based upon the water quality objectives contained in the Basin Plan.

A. Surface Water

The Mojave River Fish Hatchery pumps groundwater from the regional aquifer, uses it for hatchery operations, and discharges it to surface water that is contiguous with the local flood plain aquifer of the Mojave River. The discharge includes constituents contained in groundwater that were concentrated by evaporation, and wastes from fish hatchery operations. During storm events, constituents in storm water may also be present in the discharge. The Discharger is responsible for constituents contributed by groundwater pumping, hatchery operations and hatchery property management.

The Basin Plan contains numeric and narrative water quality objectives applicable to all surface waters within the Lahontan Region. Water quality objectives include an objective to maintain the high quality waters pursuant to federal regulations (part 131.12) and State Water Board Resolution No. 68-16. Surface water limitations in this Order are included to ensure protection of beneficial uses of the receiving waters (see section V of this Order).

The narrative objective for chemical constituents in the Basin Plan states that “*Waters shall not contain concentrations of chemicals that adversely affect the water beneficial uses.*” The receiving waters collectively have the following beneficial uses: Municipal and Domestic Supply (MUN); Agricultural Supply (AGR); Groundwater Recharge (GWR); Water Contact Recreation (REC-1); Noncontact Water Recreation (REC-2); Commercial and Sport fishing (COMM); Warm Freshwater Habitat (WARM); Cold Freshwater Habitat (COLD); Wildlife Habitat (WILD); Rare, Threatened, or Endangered Species (RARE); Migration of Aquatic Organisms (MIGR); Water Quality Enhancement (WQE); and Flood Peak Attenuation/Flood Water Storage (FLD).

The channel and wetlands to which the Facility discharges at Discharge Point 001 are effluent dominated. The golf course ponds, Spring Valley Lake, Horseshoe Lake, and Pelican Lake consist of effluent mixed with water from additional sources. Thus, no physical upstream receiving water monitoring locations exist outside the influence of the discharges from Discharge Points 001 and 002. Therefore, consistent with Order R6V-2011-0081, compliance with numeric receiving water limitations shall be measured at Monitoring Location EFF-001.

B. Groundwater

The Basin Plan contains numeric and narrative water quality objectives applicable to all groundwaters within the Lahontan Region. Groundwater quality objectives include an objective to maintain the high quality waters pursuant to State Water Board Resolution No. 68-16. The Upper Mojave River Valley Groundwater Basin has the following beneficial uses: Municipal and Domestic Supply (MUN); Agricultural Supply (AGR); Industrial Service Supply (IND); Freshwater Replenishment (FRSH); and Aquaculture (AQUA).

Beneficial uses designated to the Mojave River apply to the subsurface flow beneath the Mojave River Flood Plain. These subsurface flows may not be visible in many sections of the Mojave River during the dry season, yet they are both present and contiguous with intermittent sections of the river that contain perennial surface flows. Qualitative and numeric limitations for the Mojave River apply to these subsurface flows. Since the surface and subsurface flows in the Mojave River are connected, impacts to groundwater under the river channel are monitored with samples collected from surface water shortly prior to infiltration to the subsurface.

VI. RATIONALE FOR PROVISIONS

A. Standard Provisions

Standard Provisions, which apply to all NPDES permits in accordance with 40 C.F.R. section 122.41, and additional conditions applicable to specified categories of permits in accordance with 40 C.F.R. section 122.42, are provided in Attachment D. The Discharger must comply with all standard provisions and with those additional conditions that are applicable under section 122.42.

Sections 122.41(a)(1) and (b) through (n) of 40 C.F.R. establish conditions that apply to all state-issued NPDES permits. These conditions must be incorporated into the permits either expressly or by reference. If incorporated by reference, a specific citation to the regulations must be included in the Order. Section 123.25(a)(12) of 40 C.F.R. allows the state to omit or modify conditions to impose more stringent requirements. In accordance with 40 C.F.R. section 123.25, this Order omits federal conditions that address enforcement authority specified in 40 C.F.R. sections 122.41(j)(5) and (k)(2) because the enforcement authority under the Water Code is more stringent. In lieu of these conditions, this Order incorporates by reference Water Code section 13387(e).

B. Special Provisions

1. Reopener Provisions

These provisions are based on 40 C.F.R. section 122.62 and allow modification of this Order and its effluent limitations as necessary in response to updated water quality objectives, regulations, or other new relevant information that may be established in the future and other circumstances as allowed by law.

2. Special Studies and Additional Monitoring Requirements

- a. Chemical and Aquaculture Drug Use.** Prior to using any new chemical or aquaculture drug at the Facility, the Discharger is required to submit to the Lahontan Water Board supplemental information (e.g., name, purpose, amount to be used) and toxicity testing data for the new chemical or aquaculture drug as specified in Section VI.C.2.a of this Order. These reporting and toxicity testing requirements are needed for the Lahontan Water Board to determine if the discharge of a new drug or chemical by the Facility has reasonable potential to cause, or contribute to an in-stream excursion above any chemical-specific water quality criteria, narrative water

quality objective for chemical constituents from the Basin Plan, or narrative water quality objective for toxicity from the Basin Plan.

- b. Reporting of Unanticipated Discharges.** Consistent with Order R6V-2011-0081, this Order requires the Discharger to provide an oral report within 24 hours and a written report within 7 days of: (1) discovery of the failure in, or damage to, the settling pond or an aquatic animal containment system resulting in an unanticipated material discharge of pollutants to waters of the United States or State; and (2) a spill of drugs, chemicals, pesticides, or feed that results in a discharge to waters of the United States or State.

3. Best Management Practices and Pollution Prevention

- a. Best Management Practices (BMP) Plan – Aquaculture Operations.** BMP plan requirements are established based on requirements in the ELGs for the Concentrated Aquatic Animal Production Point Source Category at 40 C.F.R. part 451. CAAP facilities that are subject to the federal ELGs are required to develop and maintain a BMP plan that addresses the following requirements: solids control, material storage, structural maintenance, recordkeeping, and training. The Discharger must make the BMP plan available to the Lahontan Water Board upon request, and submit certification that the BMP plan has been developed.
- b. Storm Water Pollution Prevention Plan (SWPPP).** This Order requires the Discharger to develop and implement a SWPPP, in accordance with Attachment I to the Order that describes site-specific BMPs for minimizing contamination of storm water runoff and for preventing contaminated storm water runoff from being discharged directly to waters of the State. Storm water runoff at the Facility has the potential to come in contact with pollutants associated with aquaculture activities such as chemicals, fuel, waste oil, vehicle wash water, and other storage of other materials.

4. Construction, Operation, and Maintenance Specifications

- a.** Solid waste disposal provisions in this Order are based on the requirements of CCR Title 27 and prevention of unauthorized discharge of solid wastes into waters of the United States or waters of the State. Other construction, operation, and maintenance specifications are required to prevent other unauthorized discharges to waters of the United States or waters of the State.
- b.** This Order authorizes the Discharger to discharge up to 1,000 gallons of recirculated water from the recirculated water aeration tower to the adjacent drainage ditch no more than once every 12 months. The drainage ditch is not considered a water of the United States or the State. In order to limit the discharge of pollutants in storm water and minimize erosion in the drainage ditch, this Order requires the Discharger to ensure discharges from the aeration tower occurs during dry weather conditions in a manner that ensures percolation of the planned discharges within 100 feet and minimizes erosion within the drainage channel.

5. Special Provisions for Municipal Facilities (POTWs Only) – Not Applicable

6. Other Special Provisions – Not Applicable

7. Compliance Schedules – Not Applicable

VII. RATIONALE FOR MONITORING AND REPORTING REQUIREMENTS

CWA section 308 and 40 C.F.R. sections 122.41(h), (j)-(l), 122.44(i), and 122.48 require that all NPDES permits specify monitoring and reporting requirements. Water Code sections 13267 and 13383 also authorize the Lahontan Water Board to establish monitoring, inspection, entry, reporting, and recordkeeping requirements. The Monitoring and Reporting Program (MRP), Attachment E of this Order, establishes monitoring, reporting, and recordkeeping requirements that implement federal and state requirements. The following provides the rationale for the monitoring and reporting requirements contained in the MRP for this Facility.

A. Influent Monitoring

Influent monitoring is required to collect data on the characteristics of the wastewater and to assess compliance with effluent limitations (i.e., use for calculating intake credits).

1. Monitoring Location INF-001

- a. Influent monitoring frequencies and sample types for electrical conductivity, fluoride, pH, temperature have been retained from Order No. R6V-2011-0081 to assess the levels of pollutants in the extracted groundwater for these parameters. In addition, the influent monitoring frequencies and sample type for flow, pH, hardness, temperature, and zinc have been retained from Order No. R6V-2011-0081 to assess the quality of the influent for these parameters.
- b. Monitoring data collected over the term of Order No. R6V-2011-0081 for boron, chloride, nitrate, total nitrogen, sulfate, total dissolved solids, and total orthophosphate did not demonstrate reasonable potential to exceed water quality objectives/criteria. Monitoring requirements for total orthophosphate have been discontinued, as there are no applicable water quality objectives and the Discharger does not add orthophosphate to the water. The monitoring frequency for the remaining pollutants has been revised from quarterly to annually.
- c. Influent hardness data is not necessary to determine compliance with the requirements of this Order. Therefore, influent monitoring requirements for hardness have been discontinued in this Order.

B. Effluent Monitoring

Pursuant to the requirements of 40 C.F.R. section 122.44(i)(2), effluent monitoring is required for all constituents with effluent limitations. Effluent monitoring is necessary to assess compliance with effluent limitations, and to assess the impacts of the discharge on the receiving stream and groundwater.

Order No. R6V-2011-0081 specified effluent monitoring at Monitoring Location M-001, located at the splitter box prior to discharges at Discharge Points 001 and 002 (except for total combined flow, which is measured at the outfall of the settling pond after the split to the settling basin and prior to the final splitter box and sluice gate). Order No. R6V-2011-0081 required flow monitoring at Monitoring Location EFF-002, located in the discharge channel for Discharge Point 002. Order R6V-2011-0081 required the Discharger to calculate the flow to Discharge Point 001 at Monitoring Location D-001/EFF-001 by subtracting the flow rate at Monitoring Location EFF-002 from the total flow at Monitoring Location M-001. To be consistent with standard nomenclature for monitoring locations, this Order revises the monitoring location names, as follows:

Table F-17. Monitoring Location Nomenclature

Monitoring Location Description	Name in Order R6V-2011-0081	Revised Name
From the final splitter box at the outfall of the settling pond.	M-001	EFF-001
In the surface water channel to the Spring Valley Lake Home Owners Association property, after the splitter box and before the channel terminates at Pond 1.	EFF-002	EFF-002
Effluent flow to the Mojave River and adjacent wetlands from Discharge Point 001 (calculated).	D-001/EFF-001	EFF-003

Monitoring for total combined flow shall be measured at the outfall of the settling pond after the split to the second settling basin and prior to the final splitter box and sluice gate.

1. Monitoring Location EFF-001

- a. Effluent monitoring frequencies and sample type for fluoride, formaldehyde, hydrogen peroxide, pH, potassium permanganate, settleable solids, and TSS have been retained from Order No. R6V-2011-0081 to determine compliance with effluent limitations for these parameters. In addition, the effluent monitoring frequencies and sample type for flow, boron, chloramine-T, dissolved oxygen, electrical conductivity, hardness, PVP Iodine, and temperature have been retained from Order No. R6V-2011-0081 to assess the quality of the effluent for these pollutants.
- b. Monitoring data collected over the previous permit term for ammonia, chloride, nitrate, total nitrogen, sulfate, total dissolved solids, and total orthophosphate did not demonstrate reasonable potential to exceed water quality objectives/criteria. Monitoring requirements for total orthophosphate have been discontinued, as there are no applicable water quality objectives and the Discharger does not add orthophosphate to the water. The monitoring frequency for the remaining pollutants has been revised from quarterly to annually.
- c. Monitoring data collected over the previous permit term for manganese indicates that the discharges from the Facility exhibit reasonable potential to cause or contribute to an exceedance of the applicable water quality objectives, and effluent limitations have been established in this Order. This Order establishes quarterly effluent monitoring for manganese to determine compliance with the applicable effluent limitations.

2. Monitoring Locations EFF-002 and EFF-003

- a. Consistent with Order No. R6V-2011-0081, this Order requires flow monitoring at Monitoring Locations EFF-002 and EFF-003 to determine the flow at Discharge Points 001 and 002. Effluent flow at Monitoring Location EFF-003 shall be determined by subtracting the flow measured at Monitoring Location EFF-002 from the total combined flow measured at Monitoring Location EFF-001.

C. Whole Effluent Toxicity Testing Requirements – Not Applicable

D. Receiving Water Monitoring

The channel and wetlands to which the Facility discharges at Discharge Point 001 are effluent dominated. The golf course ponds, Spring Valley Lake, Horseshoe Lake, and Pelican Lake consist of effluent mixed with water from additional sources. Thus, no physical upstream receiving water monitoring locations exist outside the influence of the discharges from Discharge Points 001 and 002. Therefore, consistent with Order No. R6V-2011-0081, this Order does not require receiving water monitoring. Compliance with numeric receiving water limitations shall be measured at Monitoring Location EFF-001.

1. Surface Water – Not Applicable

2. Groundwater – Not Applicable

E. Other Monitoring Requirements

1. Quarterly Drug and Chemical Use Report

Quarterly reporting of drug and chemical use is required in this Order. The ELGs at 40 C.F.R. part 451 require reporting on the use of drugs, disinfectants, and other chemicals in discharges authorized by NPDES permits.

2. Priority Pollutant Metal Monitoring

Potential discharge of priority pollutants is based on the probability of the pollutants being present in the groundwater pumped from source wells and from data collected from CAAP facilities. Data compiled from CAAP facilities, local drinking water wells and the State Water Board's Groundwater Ambient Monitoring Association (GAMA) database were used to determine the potential for metals and other priority pollutants to occur. Accordingly, the Lahontan Water Board requires sampling and analysis of the influent and effluent for priority pollutants listed in Attachment J at least once per permit cycle. The samples shall be analyzed for priority pollutants in the year 2019 and reported to the Water Board no later than February 1, 2020. (Refer to Attachment J for the specific monitoring requirements.)

3. Annual Best Management Practices (BMP) Plan and Storm Water Pollution Prevention Plan (SWPPP) Reporting

Consistent with Order R6V-2011-0081, this Order requires annual certification that the BMP Plan and SWPPP meet the requirements of this Order and are being implemented as written.

4. Visual Observations

Consistent with Order R6V-2011-0081, this Order requires visual observations within 2 business days of a qualifying rain event to identify whether BMPs were adequately designed, implemented, and effective and to identify additional BMPs necessary. This Order also requires quarterly visual observations of non-storm water discharges to ensure that BMPs are being implemented and are effective.

5. Discharge Monitoring Report-Quality Assurance (DMR-QA) Study Program

Under the authority of section 308 of the CWA (33 U.S.C. § 1318), USEPA requires all dischargers under the NPDES Program to participate in the annual DMR-QA Study Program, including all minor dischargers beginning in 2017. The DMR-QA Study evaluates the analytical ability of laboratories that routinely perform or support self-monitoring analyses required by NPDES permits. There are two options to satisfy the requirements of the DMR-QA Study Program: (1) The Discharger can obtain and analyze a DMR-QA sample as part of the DMR-QA Study; or (2) Per the waiver issued by USEPA to the State Water Board, the Discharger can submit the results of the most recent Water Pollution Performance Evaluation Study from its own laboratories or its contract laboratories. A Water Pollution Performance Evaluation Study is similar to the DMR-QA Study. Thus, it also evaluates a laboratory's ability to analyze wastewater samples to produce quality data that ensure the integrity of the NPDES Program. The Discharger shall ensure that the results of the DMR-QA Study or the results of the most recent Water Pollution Performance Evaluation Study are submitted annually to the State Water Board. The State Water Board's Quality Assurance Program Officer will send the DMR-QA Study results or the results of the most recent Water Pollution Performance

Evaluation Study to USEPA's DMR-QA Coordinator and Quality Assurance Manager.

VIII. PUBLIC PARTICIPATION

The Lahontan Water Board has considered the issuance of WDRs that will serve as an NPDES permit for the Mojave River Fish Hatchery. As a step in the WDR adoption process, the Lahontan Water Board staff has developed tentative and proposed WDRs and has encouraged public participation in the WDR adoption process.

A. Notification of Interested Parties

The Lahontan Water Board notified the Discharger and interested agencies and persons of its intent to prescribe WDRs for the discharge and provided an opportunity to submit written comments and recommendations. Notification was provided through the Lahontan Water Board's Lyris List on <DATE>.

The public had access to the agenda and any changes in dates and locations through the Lahontan Water Board's website at: <http://www.waterboards.ca.gov/lahontan>

B. Written Comments

Interested persons were invited to submit written comments concerning tentative and proposed WDRs as provided through the notification process. Comments were due either in person or by mail to the Executive Officer at the Lahontan Water Board at the address on the cover page of this Order.

To be fully responded to by staff and considered by the Lahontan Water Board, the written comments were due at the Lahontan Water Board office by 5:00 p.m. on **March 31, 2017**

C. Public Hearing Opportunity

The Lahontan Water Board held a public meeting and provided an opportunity for interested parties to testify in a public hearing on the proposed WDRs during its regular Board meeting on the following date and time and at the following location:

Date: **May 10-11, 2017**
Time: **To be determined**
Location: California Regional Water Quality Control Board, Lahontan Region
Annex Hearing Room
971 Silver Dollar Ave.
South Lake Tahoe, CA 96150

Interested persons were invited to attend. At the public meeting, the Lahontan Water Board heard any testimony pertinent to the discharge, WDRs, and permit. For accuracy of the record, important testimony was requested in writing.

D. Reconsideration of Waste Discharge Requirements

Any aggrieved person may petition the State Water Board to review the decision of the Lahontan Water Board regarding the final WDRs. The petition must be received by the State Water Board at the following address within 30 calendar days of the Lahontan Water Board's action:

State Water Resources Control Board
Office of Chief Counsel
P.O. Box 100, 1001 I Street
Sacramento, CA 95812-0100

For instructions on how to file a petition for review, see
http://www.waterboards.ca.gov/public_notices/petitions/water_quality/wqpetition_instr.shtml

E. Information and Copying

The Report of Waste Discharge, other supporting documents, and comments received are on file and may be inspected at the address above at any time between 8:30 a.m. and 4:45 p.m., Monday through Friday. Copying of documents may be arranged through the Lahontan Water Board by calling (530) 542-5400.

F. Register of Interested Persons

Any person interested in being placed on the mailing list for information regarding the WDRs and NPDES permit should contact the Lahontan Water Board, reference this facility, and provide a name, address, and phone number.

G. Additional Information

Requests for additional information or questions regarding this Order should be directed to Cathe Pool at (530) 542-5460.

ATTACHMENT G – AQUACULTURE DRUGS AND CHEMICALS APPROVED FOR USE

Drug or Chemical	Purpose of Application	Expected Method(s) of Application or Treatment
Acetic acid	Control of external parasites.	Flush: 1.5 to 2.2 gallons of glacial acetic acid added as a bolus to top of raceway. Gives a treatment of level of approximately 335 to 500 ppm acetic acid. Bath: used at a rate of 500 to 2,000 ppm for 1 to 10 minutes.
Amoxicillin trihydrate	Control and prevention of external and systemic bacterial infections.	Injected intraperitoneally: into broodstock twice a week, prior to spawning, at a rate of 40 milligrams amoxicillin per kilogram of fish.
Carbon Dioxide	Anesthetic.	Bath: bubbled in water. Usually used in small volumes of water.
Chloramine-T. Halamide Aqua	Control of external gill bacteria.	Flush or bath: dosage of 12-20 ppm for one hour daily or every other day for three treatments. Bath: used at a concentration of 20 ppm for one hour.
Chorulon® - Chorionic Gonadotropin	Aid in improving spawning function	Intramuscular injection: Males: 50-510 IU/lb, Females: 67-1816 IU/lb,
Enteric Redmouth (ERM) Vaccine	Prevent Redmouth disease	Dip. Vaccine dumped after use. Not surface discharged.
Epsom Salt (Magnesium Sulfate)	Control internal parasites.	Feed: used in “medicated” feed or fish pills at a rate of 100 milligrams per kilogram of fish or top coated onto feed at 3% (30 gms per kg) for 3 days..
Erythromycin	Control and prevention of external and systemic bacterial infections.	Injected intraperitoneally: at a rate of 40 milligrams erythromycin per kilogram of fish, at 30 day intervals. Feed: used in medicated feed or fish pills at a rate of 100 milligrams or less of erythromycin per kilogram of fish.
Florfenicol (Nufloor®)	Control and prevention of external and systemic bacterial infections.	Medicated Feed: 10-15 mg/kg of fish for 10 consecutive days.
Formalin (37% formaldehyde solution)	Control of external parasites. Fungus control on fish eggs.	Flush: Low dose - used at a concentration of 25 ppm of formalin for 8 hours. High dose - used at a concentration of 50 to 250 ppm formalin for one hour for three treatments or as prescribed.. Bath: used at a concentration of 2,000 ppm formalin, or less, for 15 minutes. Repeat in 5 to 10 days unless or as prescribed.
Hydrogen peroxide	Control of external parasites.	Flush: used at a rate of 100 ppm, or less, for 30 minutes to 1 hour every other day for up to three treatments or as prescribed.
Ivermectin	Control of parasites	Injected intramuscularly: (0.1 mg/kg) once a week up to two injections or as prescribed.

Drug or Chemical	Purpose of Application	Expected Method(s) of Application or Treatment
MS-222 / tricaine methanesulfonate (Finquel®, Tricaine-S®)	Anesthetic or euthanasia.	Bath: used at a rate of 50 to 1,000 mg/L, usually in a small volume of water.
Ovaplant® Salmon Gonadotropin-releasing hormone analogue (sGnRHa)	Induce gamete maturation	Dorsal injection pellet-implant: 10 - 75 microgram (µg) sGnRHa per kilogram (kg) body weight. Maximum 150 µg sGnRHa per kg body weight in certain situations involving very small brood fish (e.g. fish <1 kg bw) or as prescribed.
Oxytetracycline HCl (Terramycin®)	Control and prevention of external and systemic bacterial infections.	Bath: used in tanks for six to eight hours at a concentration of 100 ppm or less. Feed: fed at a rate of 3.75 grams of oxytetracycline per 100 pounds of fish per day.
Oxytetracycline dihydrate (Terramycin® 200)	Antibiotic and bacteriostat.	Additive to feed: 3.75 g/100 lbs of fish/day for 10 days.
Penicillin G potassium	Control and prevention of external and systemic bacterial infections.	Bath: used in tanks for six to eight hours at a concentration of 150 IU/ml (500,000,000 IU/311.8 gm. Packet).
Potassium Permanganate (Cairox™)	Control of external parasites and bacteria.	Flush: up to 2 ppm at one hour for up to 3 consecutive treatment days. Bath: used at a rate of 2 ppm, or less, for one hour.
PVP Iodine	Disinfect and control diseases on fish eggs.	Bath: used at a concentration of 100 mg/L for 10 to 30 minutes.
SLICE (emamectin benzoate;0.2% aquaculture premix)	Copepods	Medicated feed: 50 µg emamectin benzoate/Kg of fish biomass/day for 7 consecutive days.
Sodium bicarbonate	Anesthetic.	Bath: used at a rate of 142 to 642 mg/L, usually in a small volume of water.
Sodium chloride (salt)	Fish cleansing, disease control, and stress reduction.	Flush: used at a rate of up to 333‰ for 1 hour, daily if needed. Or at a lesser concentration during transport.
Sulfadimethoxine-orometoprim (Romet-30®)	Control and prevention of external and systemic bacterial infections.	Feed: used at a rate of 50 milligrams of drug per kilogram of fish per day.
Vibrio vaccine	Prevention of Vibrio infections	Dip: Vaccine dumped after use. Not discharged.

ATTACHMENT H – DRUG AND CHEMICAL USAGE REPORT TABLE

The Discharger shall provide the information required in section IX.A of the Monitoring and Reporting Program (Attachment E) using the table below for all aquaculture drugs or chemicals used at the Facility, including those administered by injection or in medicated feed. See the Monitoring and Reporting Program for additional information for completing the table.

Drug or Chemical Name	Date & Time	Purpose	Amount Applied	Units	Location Where Applied	Treatment Type (immersion, feed, injected)	Flow Treated (cfs)	Total Effluent Flow (cfs)	Effluent Concentration (mg/L) ¹	Water Quality Objective (mg/L) ¹	Person Reporting

¹ Completion of this column is only required for drugs and chemicals applied directly in water. See section IX.A of the Monitoring and Reporting Program (Attachment E) for additional information for completing this column.

DRUG AND CHEMICAL NON-USE TABLE

Drug or Chemical Name	Reporting Quarter	Used or Not Used
Acetic acid		
Amoxicillin trihydrate		
Carbon Dioxide		
Chloramine-T. Halamide Aqua		
Chorulon® - Chorionic Gonadotropin		
Enteric Redmouth (ERM) Vaccine		
Epson Salt (Magnesium Sulfate)		
Erythromycin		
Florfenicol (Nuflor®)		
Formalin (37% formaldehyde solution)		
Hydrogen peroxide		
Ivermectin		
MS-222 / tricaine methanesulfonate (Finquel®, Tricaine-S®)		
Ovaplant®		
Salmon Gonadotropin-releasing hormone analogue (sGnRH _a)		
Oxytetracycline HCl (Terramycin®)		
Oxytetracycline dihydrate (Terramycin® 200)		
Penicillin G potassium		
Potassium Permanganate (Cairox™)		
PVP Iodine		
SLICE (emamectin benzoate;0.2% aquaculture premix)		
Sodium bicarbonate		
Sodium chloride (salt)		
Sulfadimethoxine-ormetoprim (Romet-30®)		
Vibrio vaccine		
List Other Chemical and Drugs used		

ATTACHMENT I – STORM WATER POLLUTION PREVENTION PLAN REQUIREMENTS

I. Objectives

The SWPPP has two major objectives: (a) to identify and evaluate sources of pollutants associated with Facility activities that may affect the quality of storm water discharges and authorized non-storm water discharges from the Facility; and (b) to identify and implement site-specific best management practices (BMPs) to reduce or prevent pollutants associated with Facility activities in storm water discharges and authorized non-storm water discharges. BMPs may include a variety of pollution prevention measures or other low-cost and pollution control measures. They are generally categorized as non-structural BMPs (activity schedules, prohibitions of practices, maintenance procedures, and other low-cost measures) and as structural BMPs (treatment measures, run-off controls, over-head coverage.) To achieve these objectives, the Discharger shall consider the five phase process for SWPPP development and implementation as shown in Table I-1.

The SWPPP requirements are designed to be sufficiently flexible to meet the needs of the Facility. SWPPP requirements that are not applicable to the Facility should not be included in the SWPPP.

A SWPPP is a written document that shall contain a compliance activity schedule, a description of Facility activities and pollutant sources, descriptions of BMPs, drawings, maps, and relevant copies or references of parts of other plans. The SWPPP shall be revised whenever appropriate, at least annually, and shall be readily available for review by facility employees or Lahontan Water Board inspectors.

Table I-1. Five Phases for Developing and Implementing Industrial SWPPPs

PLANNING AND ORGANIZATION Form Pollution Prevention Team Review other plans
ASSESSMENT PHASE Develop a site map Identify potential pollutant sources Inventory of materials and chemicals List significant spills and leaks Identify non-storm water discharges Assess pollutant risks
BEST MANAGEMENT PRACTICES IDENTIFICATION PHASE Non-structural BMPs Structural BMPs Select activity and site-specific BMPs
IMPLEMENTATION PHASE Train employees Implement BMPs Conduct recordkeeping and reporting
EVALUATION / MONITORING Conduct annual site evaluation Review monitoring information Evaluate BMPs Review and revise SWPPP

II. Planning and Organization

The SWPPP shall identify a specific individual or individuals and their positions within the Discharger's organization as members of a storm water pollution prevention team responsible for developing the SWPPP, assisting the Facility manager in SWPPP implementation and revision, and conducting all monitoring program activities. The SWPPP shall clearly identify the Permit-related responsibilities, duties, and activities of each team member. Storm water pollution prevention teams may consist of one individual where appropriate.

III. Site Map

The SWPPP shall include a site map. The site map size shall be at least 8-½ x 11 inches but no larger than 11 X 17 inches and include notes, legends, and other data as appropriate to ensure that the site map is clear and understandable. If necessary, facility operators may provide the required information on multiple site maps.

The following information shall be included on the site map:

- A.** The Facility boundaries; the outline of all storm water drainage areas within the Facility boundaries; portions of the drainage area impacted by run-on from surrounding areas; and direction of flow of each drainage area, on-site surface water bodies, and areas of soil erosion. The map shall also identify nearby water bodies and storm drain inlets where the facility's storm water discharges and authorized non-storm water discharges may be received.
- B.** The location of the storm water collection and conveyance system, associated points of discharge, and direction of flow. Include any structural control measures that affect storm water discharges, authorized non-storm water discharges, and run-on. Examples of structural control measures are catch basins, berms, detention ponds, secondary containment, oil/water separators, diversion barriers, etc.
- C.** An outline of all impervious areas of the Facility, including paved areas, buildings, covered storage areas, or other roofed structures.
- D.** Locations where materials are directly exposed to precipitation and the locations where significant spills or leaks identified have occurred.
- E.** Locations of all chemical storage areas and storage tanks, fueling areas, vehicle and equipment storage/maintenance areas, cleaning and rinsing areas, and other areas of activity which are potential pollutant sources.

IV. List of Significant Materials

The SWPPP shall include a list of significant materials handled and stored at the Facility. For each material on the list, describe the locations where the material is being stored, as well as the typical quantities.

V. Description of Potential Pollutant Sources

- A.** The SWPPP shall include a narrative description of the Facility activities, associated potential pollutant sources, and potential pollutants that could be discharged in storm water discharges or authorized non-storm water discharges. At a minimum, the following items related to the Facility's activities shall be considered:
 - 1.** Describe the type, characteristics, and quantity of significant materials used in or stored on site and a description of the cleaning, rinsing, disposal, or other activities related to Facility's operation. Where applicable, areas protected by containment structures and the corresponding containment capacity shall be described.

2. Material Handling and Storage Areas. Describe each handling and storage area, type, characteristics, and quantity of significant materials handled or stored and the spill or leak prevention and response procedures. Where applicable, areas protected by containment structures and the corresponding containment capacity shall be described.
 3. Describe materials that have spilled or leaked in significant quantities in storm water discharges or non-storm water discharges. The description shall include the type, characteristics, and approximate quantity of the material spilled or leaked, the cleanup or remedial actions that have occurred or are planned, the approximate remaining quantity of materials that may be exposed to storm water or non-storm water discharges, and the preventative measures taken to ensure spill or leaks do not reoccur.
 4. **Non-Storm Water Discharges.** Investigate the Facility to identify all non-storm water discharges and their sources. As part of this investigation, all drains (inlets and outlets) shall be evaluated to identify whether they connect to a storm drain system. (Examples of prohibited non-storm water discharges are contact and non-contact cooling water, rinse water, wash water, etc.). The SWPPP must include BMPs to prevent or reduce contact of non-storm water discharges with significant materials or equipment.
- B. The SWPPP shall include a summary of all areas potential pollutant sources, and potential pollutants. This information should be summarized similar to Table I-2.

Table I-2. Example Assessment of Potential Pollutant Sources and Corresponding BMP Summary

Area	Activity	Source	Pollutant	Best Management Practices
Vehicle & Equipment Fueling	Fueling	Spills and leaks during delivery. Spills caused by topping off fuel tanks. Hosing or washing down fuel oil fuel area. Leaking storage tanks. Rainfall running off fuel oil, and rainfall running onto and off fueling area.	fuel oil	Use spill and overflow protection. Minimize run-on of storm water into the fueling area. Cover fueling area. Use dry cleanup methods rather than hosing down area. Implement proper spill prevention control program. Implement adequate preventative maintenance program to preventive tank and line leaks. Inspect fueling areas regularly to detect problems before they occur. Train employees on proper fueling, cleanup, and spill response techniques.

VI. Assessment of Potential Pollutant Sources

- A. The SWPPP shall include a narrative assessment of all Facility activities and potential pollutant sources to determine:
1. Which areas of the Facility are likely sources of pollutants in storm water discharges and authorized non-storm water discharges, and
 2. Which pollutants are likely to be present in storm water discharges and authorized non-storm water discharges. Facility operators shall consider and evaluate various factors when performing this assessment such as current storm water BMPs; quantities of significant materials stored or disposed of; likelihood of exposure to storm water or

authorized non-storm water discharges; history of spill or leaks; and run-on from outside sources.

- B. Facility operators shall summarize the areas of the facility that are likely sources of pollutants and the corresponding pollutants that are likely to be present in storm water discharges and authorized non-storm water discharges. Facility operators are required to develop and implement additional BMPs as appropriate and necessary to prevent or reduce pollutants associated with each pollutant source.

VII. Storm Water Best Management Practices

The SWPPP shall include a narrative **description** of the storm water BMPs to be implemented at the Facility for each potential pollutant and its source identified in the site assessment phase. The BMPs shall be developed and implemented to reduce or prevent pollutants in storm water discharges and authorized non-storm water discharges. Each pollutant and its source may require one or more BMPs. Some BMPs may be implemented for multiple pollutants and their sources, while other BMPs will be implemented for a very specific pollutant and its source.

The description of the BMPs shall identify the BMPs as (1) existing BMPs, (2) existing BMPs to be revised and implemented, or (3) new BMPs to be implemented along with a schedule for implementation. The description shall also include a discussion on the effectiveness of each BMP to reduce or prevent pollutants in storm water discharges and authorized non-storm water discharges. The SWPPP shall provide a summary of all BMPs implemented for each pollutant source. This information should be summarized similar to Table I-2.

Facility operators shall consider the following BMPs for implementation at the Facility:

A. Non-Structural BMPs

Non-structural BMPs generally consist of processes, prohibitions, procedures, schedule of activities, etc., that prevent pollutants associated with activity from contacting with storm water discharges and authorized non-storm water discharges. They are considered low technology, cost-effective measures. The Discharger and its Facility operator shall consider all possible non-structural BMPs options before considering additional structural BMPs. Below is a list of non-structural BMPs that should be considered:

1. **Good Housekeeping.** Good housekeeping generally consists of practical procedures to maintain a clean and orderly facility.
2. **Preventive Maintenance.** Preventive maintenance includes the regular inspection and maintenance of structural storm water controls (catch basins, oil/water separators, etc.) as well as other facility equipment and systems.
3. **Spill Response.** This includes spill clean-up procedures and necessary clean-up equipment based upon the quantities and locations of significant materials that may spill or leak.
4. **Material Handling and Storage.** This includes all procedures to minimize the potential for spills and leaks and to minimize exposure of significant materials to storm water and authorized non-storm water discharges.
5. **Employee Training.** This includes training of personnel who are responsible for (1) implementing activities identified in the SWPPP, (2) conducting inspections, sampling, and visual observations, and (3) managing storm water. Training should address topics such as spill response, good housekeeping, and material handling procedures, and actions necessary to implement all BMPs identified in the SWPPP. The SWPPP shall identify periodic dates for such training. Records shall be maintained of all training sessions held.

6. **Waste Handling/Recycling.** This includes the procedures or processes to handle, store, or dispose of waste materials or recyclable materials.
7. **Recordkeeping and Internal Reporting.** This includes the procedures to ensure that all records of inspections, spills, maintenance activities, corrective actions, visual observations, etc., are developed, retained, and provided, as necessary, to the appropriate facility personnel.
8. **Inspections.** This includes, in addition to the preventative maintenance inspections identified above, an inspection schedule of all potential pollutant sources. Tracking and follow-up procedures shall be described to ensure adequate corrective actions are taken and necessary modifications to the site SWPPP are made.
9. **Quality Assurance.** This includes the procedures to ensure that all elements of the SWPPP and Monitoring Program are adequately conducted.

B. Structural BMPs

Where non-structural BMPs as identified above are not effective, structural BMPs shall be considered. Structural BMPs generally consist of structural devices that reduce or prevent pollutants in storm water discharges and authorized non-storm water discharges. Below is a list of structural BMPs that should be considered:

1. **Overhead Coverage.** This includes structures that provide horizontal coverage of materials, chemicals, and pollutant sources from contact with storm water and authorized non-storm water discharges.
2. **Retention Ponds.** This includes basins, ponds, surface impoundments, bermed areas, etc. that do not allow storm water to discharge from the facility.
3. **Control Devices.** This includes berms or other devices that channel or route run-on and runoff away from pollutant sources.
4. **Secondary Containment Structures.** This generally includes containment structures around storage tanks and other areas for the purpose of collecting any leaks or spills.
5. **Treatment.** This includes inlet controls, infiltration devices, oil/water separators, detention ponds, vegetative swales, etc., that reduce the pollutants in storm water discharges and authorized non-storm water discharges.

VIII. SWPPP General Requirements

- A. The SWPPP shall be retained on site and made available upon request of a representative of the Lahontan Water Board.
- B. The Lahontan Water Board may notify the Facility operator when the SWPPP does not meet one or more of the minimum requirements of this Section. As requested by the Lahontan Water Board, the Discharger shall submit a SWPPP revision and implementation schedule.
- C. The SWPPP shall be revised, as appropriate, and implemented prior to changes which (i) may significantly increase the quantities of pollutants in storm water discharge, (ii) cause a new area of industrial activity at the facility to be exposed to storm water, or (iii) begin an activity which would introduce a new pollutant source at the facility.
- D. When any part of the SWPPP is infeasible to implement due to proposed significant structural changes, the Discharger shall submit a report to the Lahontan Water Board that (i) describes the portion of the SWPPP that is infeasible to implement, (ii) provides justification for a time extension, (iii) provides a schedule for completing and implementing that portion of the SWPPP, and (iv) describes the BMPs that will be implemented in the interim period to reduce

or prevent pollutants in storm water discharges and authorized non-storm water discharges. Such reports are subject to Water Board approval and/or modifications.

- E. The SWPPP is considered a report that shall be available to the public by the Lahontan Water Board under Section 308(b) of the Clean Water Act.

IX. Annual Comprehensive Site Compliance Evaluation

The Discharger shall conduct one annual comprehensive site compliance evaluation in the period January 1-December 31. Evaluations shall be conducted within 8-16 months of each other. The SWPPP shall be revised, as appropriate, and the revisions implemented within 90 days of the evaluation. Evaluations shall include the following:

- A. A review of all visual observation records, inspection records, and sampling and analysis results.
- B. A visual inspection of all potential pollutant sources for evidence of, or the potential for, pollutants entering the drainage system.
- C. A review and evaluation of all BMPs (both structural and non-structural) to determine whether the BMPs are adequate, properly implemented and maintained, or whether additional BMPs are needed. A visual inspection of equipment needed to implement the SWPPP, such as spill response equipment, shall be included.
- D. An evaluation report that includes, (i) identification of personnel performing the evaluation, (ii) the date(s) of the evaluation, (iii) necessary SWPPP revisions, and (v) any incidents of noncompliance and the corrective actions taken. The evaluation report shall be submitted as part of the site's annual report and retained for at least five years.

ATTACHMENT J – PRIORITY POLLUTANT METAL MONITORING REQUIREMENTS

- I. Background.** The Lahontan Water Board has determined that, based on priority pollutant data collected from concentrated aquatic animal production (CAAP) facilities, discharge of priority pollutants other than metals is unlikely. Accordingly, the Lahontan Water Board is requiring, as part of the Monitoring and Reporting Program, that the Discharger sample the effluent and analyze the samples for priority pollutant metals. Sections 2.4.1 through 2.4.4 of the *Policy for Implementation of Toxics Standards for Inland Surface Waters, Enclosed Bays, and Estuaries of California* (State Implementation Policy or SIP) provide minimum standards for analyses and reporting. (Copies of the SIP may be obtained from the State Water Resources Control Board or downloaded from http://waterboards.ca.gov/water_issues/programs/state_implementation_policy/docs/final.pdf.) Effluent pH and hardness are required to evaluate the toxicity of metals where the toxicity of the constituents varies with pH and/or hardness.
- II. Monitoring Requirements.** Priority pollutant metal samples shall be collected for the effluent at Monitoring Location EFF-001 and analyzed for the metals listed in Table J-1 **one time in the year 2020 and reported to the Lahontan Water Board no later than February 1, 2021 in the SMR, and included in the Report of Waste Discharge.**

TABLE J-1. List of Required Priority Pollutant Metals

Constituent	Controlling Water Quality Criterion for Surface Waters		Criterion Quantitation Limit µg/L	Suggested Test Method
	Basis	Criterion Concentration µg/L		
Arsenic	Ambient Water Quality	0.018	0.01	EPA 1632
Barium	Primary MCL	1,000	100	EPA 6020/200.8
Beryllium	Primary MCL	4	1	EPA 6020/200.8
Cadmium	Public Health Goal	0.07	0.25	EPA 1638/200.8
Chromium (total)	Primary MCL	50	2	EPA 6020/200.8
Chromium (VI)	Draft Public Health Goal	0.02	0.5	EPA 7199/1636
Copper	National Toxics Rule	6.5	0.5	EPA 6020/200.8
Cyanide	National Toxics Rule	5.2	5	EPA 9012A
Iron	Secondary MCL	300	100	EPA 6020/200.8
Lead	Calif. Toxics Rule	1.8	0.5	EPA 1638
Mercury	Calif. Toxics Rule	0.050	0.0002	EPA 1669/1631
Manganese	Secondary MCL	50	20	EPA 6020/200.8
Nickel	Calif. Toxics Rule	36	5	EPA 6020/200.8
Selenium	Calif. Toxics Rule	5	5	EPA 6020/200.8
Silver	Calif. Toxics Rule	1.9	1	EPA 6020/200.8
Thallium	National Toxics Rule	1.7	1	EPA 6020/200.8
Tributyltin	Ambient Water Quality	0.063	0.002	EV-024/025
Zinc	Calif. Toxics Rule	83	10	EPA 6020/200.8

ATTACHMENT K – FEED CONVERSION RATIOS LOG

The Discharger shall utilize the following form to keep track of feeding and to calculate/track feed conversion ratios. The first row is an example row. Feed conversion ratios shall be calculated using the following equation:

$$\text{Feed Conversion Ratio} = \frac{\text{Dry weight of feed applied}}{\text{Wet weight of fish gained}}$$

Date (start date end date)	Description of Group	Total Feed Amounts (Estimate)	Weight of Animals (start weight end weight)	Weight Gained	Calculated Feed Conversion Ratio
3/20/04	Brook trout stockers for Potomac River	5,275 lbs	100 lbs	4,700 lbs	1.12
10/21/04			4,800		