

**CALIFORNIA REGIONAL WATER QUALITY CONTROL BOARD  
LAHONTAN REGION**

2501 Lake Tahoe Boulevard, South Lake Tahoe, CA 96150  
(530) 542-5400, Fax (530) 544-2271  
[State Water Resources Control Board](http://www.waterboards.ca.gov)  
(<http://www.waterboards.ca.gov>)

**ORDER NUMBER. R6-2024-0026  
NPDES NUMBER. CA0102814  
WDID NUMBER. 6B360812001**

**NATIONAL POLLUTANT DISCHARGE ELIMINATION SYSTEM (NPDES) PERMIT  
AND WASTE DISCHARGE REQUIREMENTS  
FOR THE  
CALIFORNIA DEPARTMENT OF FISH AND WILDLIFE  
MOJAVE RIVER FISH HATCHERY, SAN BERNARDINO COUNTY**

The following Discharger is subject to waste discharge requirements (WDRs) set forth in this Order:

Discharger	<b>State of California, Department of Fish and Wildlife</b>
Name of Facility	<b>Mojave River Fish Hatchery</b>
Facility Address	<b>12550 Jacaranda Avenue Victorville, California 93395 San Bernardino County</b>

**Table 1. Discharge Location**

<b>Discharge Point</b>	<b>Effluent Description</b>	<b>Discharge Point Latitude (North)</b>	<b>Discharge Point Longitude (West)</b>	<b>Receiving Water</b>
001	Fish Hatchery Wastewater	34° 28' 50" N	117° 15' 36" W	Mojave River and adjacent wetlands
002	Fish Hatchery Wastewater	34° 28' 47" N	117° 15' 45" W	Upper Mojave River Valley Groundwater Basin, Spring Valley Lake, and other minor surface waters, including wetlands

This Order was adopted on:

**April 17, 2024**

This Order shall become effective on:

**June 1, 2024**

This Order shall expire on:

**May 31, 2029**

The Discharger must file a Report of Waste Discharge as an application for reissuance of WDRs in accordance with title 23, California Code of Regulations, and an application for reissuance of a NPDES permit no later than **December 2, 2028, 180 days prior to the Order expiration date**. The U.S. Environmental Protection Agency (U.S. EPA) and the California Regional Water Quality Control Board, Lahontan Region have classified this discharge as follows: Minor.

I, Michael R. Plaziak, Executive Officer, do hereby certify that this Order with all attachments is a full, true, and correct copy of the Order adopted by the California Regional Water Quality Control Board, Lahontan Region, on **April 17, 2024**.



---

Michael R. Plaziak, Executive Officer

### TABLE OF CONTENTS

1. FACILITY INFORMATION .....	4
2. FINDINGS .....	4
3. DISCHARGE PROHIBITIONS .....	5
4. EFFLUENT LIMITATIONS AND DISCHARGE PROHIBITIONS .....	7
4.1. Effluent Limitations – Discharge Point 001 .....	7
4.2. Land Discharge Specifications – Not Applicable .....	7
4.3. Recycling Specifications – Not Applicable .....	7
4.4. Non-Storm Water Discharges Specifications .....	7
5. RECEIVING WATER LIMITATIONS .....	8
5.1. Surface Water Limitations .....	8
5.2. Groundwater Limitations .....	13
6. PROVISIONS .....	13
6.1. Standard Provisions .....	13
6.2. Monitoring and Reporting Program (MRP) Requirements .....	16
6.3. Special Provisions .....	16
7. COMPLIANCE DETERMINATION .....	22
7.1. Multiple Sample Data .....	22

### TABLE OF TABLES

Table 1. Discharge Location .....	1
Table 2. Final Effluent Limitations .....	7
Table 3. Surface Water Limitations (mg/L) .....	13

### TABLE OF ATTACHMENTS

ATTACHMENT A – Definitions .....	A-1
ATTACHMENT B – Map .....	B-1
ATTACHMENT C – Flow Schematic .....	C-1
ATTACHMENT D – Standard Provisions .....	D-1
ATTACHMENT E – Monitoring and Reporting Program .....	E-1
ATTACHMENT F – Fact Sheet .....	F-1
ATTACHMENT G – Aquaculture Drugs and Chemicals Approved for Use .....	G-1
ATTACHMENT H – Drug and Chemical Usage Report Table .....	H-1
ATTACHMENT I – Storm Water Pollution Prevention Plan Requirements .....	I-1
ATTACHMENT J – Priority Pollutant Metal Monitoring Requirements .....	J-1
ATTACHMENT K – Feed Conversion Ratios Log .....	K-1

## 1. FACILITY INFORMATION

Information describing the Mojave River Fish Hatchery (Facility) is summarized on the cover page and in sections 1 and 2 of the Fact Sheet (Attachment F). Section 1 of the Fact Sheet also includes information regarding the Facility's permit application.

## 2. FINDINGS

The California Regional Water Quality Control Board, Lahontan Region (Lahontan Water Board), finds:

- 2.1. **Legal Authorities.** This Order serves as WDRs pursuant to article 4, chapter 4, division 7 of the California Water Code (commencing with section 13260). This Order is also issued pursuant to section 402 of the federal Clean Water Act (CWA) and implementing regulations adopted by U.S. EPA and chapter 5.5, division 7 of the Water Code (commencing with section 13370). It shall serve as a NPDES permit authorizing the Discharger to discharge into waters of the United States at the discharge location described in Table 1 subject to the WDRs in this Order.
- 2.2. **Background and Rationale for Requirements.** The Lahontan Water Board developed the requirements in this Order based on information submitted as part of the application, through monitoring and reporting programs, and other available information. The Fact Sheet (Attachment F), which contains background information and rationale for the requirements in this Order, is hereby incorporated into and constitutes Findings for this Order. Attachments A through E and G through K are also incorporated into this Order.
- 2.3. **Provisions and Requirements Implementing State Law.** The provisions/requirements in subsections 4.2, 4.3, and 5.2 of this Order are included to implement state law only. These provisions/requirements are not required or authorized under the federal CWA; consequently, violations of these provisions/requirements are not subject to the enforcement remedies that are available for NPDES violations.
- 2.4. **Notification of Interested Parties.** The Lahontan Water Board has notified the Discharger and interested agencies and persons of its intent to prescribe WDRs for the discharge and has provided them with an opportunity to submit their written comments and recommendations. Details of the notification are provided in the Fact Sheet.
- 2.5. **Consideration of Public Comment.** The Lahontan Water Board, in a public meeting, heard and considered all comments pertaining to the discharge. Details of the Public Hearing are provided in the Fact Sheet.
- 2.6. **Anticipated Water Quality Impacts in Disadvantaged or Tribal Communities.** The permittees operate a concentrated cold water fish hatchery facility producing trout located on the Mojave River within the Upper Mojave Hydrologic Area in San Bernardino County. Permitting the Facility is consistent with the Lahontan Water Board's Basin Plan. The Regional Water Board has reviewed readily available information and information raised to the Board by interested persons concerning

anticipated water quality impacts in disadvantaged or tribal communities resulting from adoption of this Order. The Board also considered environmental justice concerns within the Board's authority and raised by interested persons with regard to those impacts. Effluent is either discharged directly to the Bear Valley Golf Course, not listed as a disadvantaged community, or to the Mojave River.

The Regional Water Board publicly noticed the permit and provided opportunities for public comment, consistent with Water Code Section 189.7. Public notice was provided to interested persons, Tribes, and public agencies in the region with jurisdiction over natural resources in the affected area. Based on the facility design and proposed operation, and requirements included in the permit, the discharge regulated by this Order is not expected to result in a disproportionate impact to tribal or disadvantaged communities.

THEREFORE, IT IS HEREBY ORDERED that Order R6V-2017-0025 is rescinded upon the effective date of this Order except for enforcement purposes, and, in order to meet the provisions contained in division 7 of the Water Code (commencing with section 13000) and regulations adopted thereunder, and the provisions of the CWA and regulations and guidelines adopted thereunder, the Discharger must comply with the requirements in this Order. This action in no way prevents the Lahontan Water Board from taking enforcement action for violations of the previous Order.

### **3. DISCHARGE PROHIBITIONS**

**3.1. General Requirements and Prohibitions.** In accordance with the Region-wide and Unit/Area-Specific Prohibitions in section 4.1 of the Water Quality Control Plan for the Lahontan Region (Basin Plan), unless a specific exemption is granted in writing by the Lahontan Water Board:

- 3.1.1. The discharge of waste into waters of the state that causes violation of any numeric water quality objective contained in the Basin Plan, including the Nondegradation Objective, is prohibited. For the purposes of this prohibition, "waste" is defined to include any waste or deleterious material including, but not limited to, waste earthen materials (such as soil, silt, sand, clay, rock, or other organic or mineral material) and any other waste as defined in Water Code section 13050 subdivision (d).
- 3.1.2. Where any numeric or narrative water quality objective contained in the Basin Plan is already being violated, the discharge of waste that causes further degradation or pollution is prohibited.
- 3.1.3. The discharge of waste that could affect the quality of waters of the state that is not authorized by the State Water Board or Regional Board through waste discharge requirements, NPDES permit, cease and desist order, certification of water quality compliance pursuant to CWA section 401, or other appropriate regulatory mechanism is prohibited.

- 3.1.4. The discharge of untreated sewage, garbage, or other solid wastes into surface waters of the Region is prohibited. For the purposes of this prohibition, “untreated sewage” is that which exceeds secondary treatment standards of the Federal Water Pollution Control Act, which are incorporated in section 4.4 of the Basin Plan.
- 3.1.5. The discharge of pesticides to surface or ground waters is prohibited.
- 3.2. The discharge of hatchery wastewater except to the authorized discharge points (Discharge Points 001 and 002) is prohibited.
- 3.3 There must be no discharge, bypass, or diversion from the transport or treatment facilities to surface waters except as in compliance with Standard Provisions for bypass (Attachment D).
- 3.4. The discharge must not cause pollution as defined in section 13050 of the Water Code, or a threatened pollution.
- 3.5. Neither the treatment nor the discharge shall cause a nuisance as defined in section 13050 of the Water Code.
- 3.6. The discharge must not cause a violation of any applicable water quality standards for receiving water adopted by the Lahontan Water Board or the State Water Board.
  - 3.6.1. The application of any therapeutic or pharmaceutical aquaculture drug or chemical resulting in toxicity in receiving waters is prohibited.
  - 3.6.2. The discharge or threatened discharge of any aquaculture drug or chemical not authorized for discharge in section 6.3.2.1 of this Order to waters of the state is prohibited.
  - 3.6.3. The application of more than one aquaculture drug or chemical to the raceways or incubation building per treatment period (as defined in Attachment A) is prohibited.
- 3.7. The discharge of hazardous or toxic substances including cleaning chemicals, solvents, oil, grease, or other petroleum products to waters of the state is prohibited.
- 3.8. Practices that may allow accumulated sludge, grit, and solid residues to be discharged to surface waters are prohibited.
- 3.9. The use of any aquaculture drug or chemical that may be potentially discharged to waters of the state and that are not authorized for discharge in section 6.3.2.1 of this Order is prohibited. Modifications to the authorized use and disposal of aquaculture drugs and chemicals at the Facility may be allowed by the Lahontan Water Board as specified in section 6.3.2.1 of this Order.
- 3.10. Discharges exceeding an average monthly flow of 26 million gallons per day (MGD) are prohibited.

**4. EFFLUENT LIMITATIONS AND DISCHARGE PROHIBITIONS**

**4.1. Effluent Limitations – Discharge Point 001**

4.1.1. Final Effluent Limitations – Discharge Point 001

**Table 2. Final Effluent Limitations**

<b>Parameter</b>	<b>Units</b>	<b>Average Monthly</b>	<b>Maximum Daily</b>	<b>Instantaneous Maximum</b>
Fluoride, Total	mg/L	-	0.44	-
Manganese, Total Recoverable	µg/L	50	100	-
Formaldehyde	mg/L	0.65	1.3	-
Hydrogen Peroxide	mg/L	-	1.3	-
Settleable Solids	ml/L	0.1	-	-
Total Suspended Solids (TSS)	mg/L	6.0	-	15

4.1.1.1. The Discharger must maintain compliance with the above effluent limitations at Discharge Point 001 and 002, with compliance measured at Monitoring Location EFF-001 as described in the Monitoring and Reporting Program (MRP), Attachment E.

4.1.1.2. **pH.** The pH of discharges to Discharge Points 001 and 002, with compliance measured at Monitoring Location EFF-001 as described in the Monitoring and Reporting Program, Attachment E, shall not be depressed below 6.5 standard units nor raised above 8.5 standard units. When the pH of the influent exceeds 8.5 standard units at Monitoring Location INF-001, the pH of the discharge shall not exceed the pH of the influent by more than 0.5 standard units.

**4.1.2. Interim Effluent Limitations – Not Applicable**

**4.2. Land Discharge Specifications – Not Applicable**

**4.3. Recycling Specifications – Not Applicable**

**4.4. Non-Storm Water Discharges Specifications**

4.4.1. The following non-storm water discharges are authorized by this Order provided that they satisfy the conditions specified in section 4.4.2 below: fire hydrant flushing; potable water sources, including potable water related to the operation, maintenance, or testing of potable water systems; drinking fountain water; atmospheric condensates including refrigeration, air conditioning, and compressor

condensate; irrigation drainage; landscape watering; springs; groundwater; foundation or footing drainage.

4.4.2. The non-storm water discharges as identified in section 4.4.1 above, are authorized by this Order if all the following conditions are met:

4.4.2.1. The non-storm water discharges are in compliance with these waste discharge requirements.

4.4.2.2. Best Management Practices (BMPs) are specifically included in a Storm Water Pollution Prevention Plan (SWPPP) to (1) prevent or reduce the contact of non-storm water discharges with materials or equipment which may contribute contaminants to the discharge and (2) minimize, to the extent practicable, the flow or volume of non-storm water discharges.

4.4.2.3. The monitoring program includes quarterly visual observations of each non-storm water discharge and its sources to ensure that BMPs are being implemented and are effective.

4.4.2.4. The non-storm water discharges are reported and described in the subsequent quarterly report and are summarized in the annual report.

## 5. RECEIVING WATER LIMITATIONS

Receiving water limitations are based on water quality objectives contained in the Basin Plan and are a required part of this Order. Compliance with numeric and narrative receiving water limitations must be measured at Monitoring Location EFF-001. The discharge must not cause the following in the Mojave River:

### 5.1. Surface Water Limitations

5.1.1. This Discharger must not cause a violation of any applicable water quality standard for receiving water adopted by the Lahontan Water Board or the State Water Board as required by the federal Water Pollution Control Act and regulations adopted thereunder.

5.1.2. **Water Quality Objectives Which Apply to All Surface Waters:** The discharge to surface waters of flows generated within, or as a result of, the Facility must not cause a violation of the following water quality objectives for the surface waters of the Upper Mojave Hydrologic Area:

5.1.2.1. **Ammonia.** Ammonia concentrations must not exceed the values listed for the corresponding conditions in Table 3-1 and 3-3 of the Basin Plan. For temperature and pH values not explicitly in the tables, the most conservative value neighboring the actual value may be used or criteria can be calculated from numerical formulas developed by the USEPA. The neutral, unionized ammonia species ( $\text{NH}_3$ ) is highly toxic to freshwater fish. The fraction of toxic  $\text{NH}_3$  to total ammonia species ( $\text{NH}_4^+ + \text{NH}_3$ ) is a function of temperature and pH. Basin Plan Tables 5.1-5 to 5.1-6 were derived from USEPA ammonia criteria for freshwater.

5.1.2.2. **Bacteria, Coliform.** Waters must not contain concentrations of coliform organisms attributable to anthropogenic sources, including human and livestock



wastes. The fecal coliform concentration during any 30-day period shall not exceed a log mean most probable number (MPN) of 20 per 100 mL, nor shall more than 10 percent of all samples collected during any 30-day period exceed 40 MPN per 100 mL. U.S. EPA recommends that the log mean should ideally be based on a minimum of not less than five samples collected as evenly spaced as practicable during any 30-day period (Reference: Ambient Water Quality Criteria for Bacteria – 1986, EPA 440/5-84-002, page 2). However, a log mean concentration exceeding 20 MPN per 100 mL for any 30-day period shall indicate violation of this objective even if fewer than five samples were collected.

5.1.2.3. **Biostimulatory Substances.** Waters shall not contain biostimulatory substances in concentrations that promote aquatic growths to the extent that such growths cause nuisance or adversely affect the water for beneficial uses.

5.1.2.4. **Chemical Constituents.** Waters shall not contain concentrations of chemical constituents in amounts that adversely affect the water for beneficial uses.

The receiving waters have been designated as municipal and domestic supply (MUN) and must not contain concentrations of chemical constituents in excess of the maximum contaminant level (MCL) or secondary maximum contaminant level (SMCL) established for drinking water and specified in Title 22 of the California Code of Regulations, which are incorporated by reference into this Order: Table 64431-A (MCLs for Inorganic Chemicals), Table 64444-A (MCLs for Organic Chemicals), Table 64449-A (Secondary MCLs, Consumer Acceptance Limits), and Table 64449-B (Secondary MCLs, Ranges). This incorporation-by-reference is prospective and therefore includes future changes to the incorporated provisions, as changes take effect.

Waters designated as agricultural supply (AGR) must not contain concentrations of chemical constituents in amounts that adversely affect the water for beneficial uses (i.e., agricultural purposes).

5.1.2.5. **Chlorine, Total Residual.** For the protection of aquatic life, total chlorine residual must not exceed either a median value of 0.002 mg/L or a maximum value of 0.003 mg/L in the receiving water. Median values shall be based on daily measurements taken within any six-month period.

5.1.2.6. **Color.** Waters shall be free of coloration that causes nuisance or adversely affects the water for beneficial uses.

5.1.2.7. **Dissolved Oxygen.** The dissolved oxygen concentration, as percent saturation, must not be depressed by more than 10 percent, nor shall the minimum dissolved oxygen concentration be less than 80 percent of saturation. For waters with the beneficial uses of COLD, COLD with SPWN, WARM, and WARM with SPWN, the minimum dissolved oxygen concentration shall not be less than that specified in Table 3-6 of the Basin Plan.

5.1.2.8. **Floating Materials.** Waters must not contain floating materials, including solids, liquids, foams, and scum, in concentrations that cause nuisance or

adversely affect the water for beneficial uses. For natural high-quality waters, the concentrations of floating material must not be altered to the extent that such alterations are discernible at the 10 percent significance level.

5.1.2.9. **Nondegradation of Aquatic Communities and Populations.** All wetlands must be free of substances attributable to wastewater or other discharges that produce adverse physiological responses in humans, animals, or plants; or that lead to the presence of undesirable or nuisance aquatic life. All wetlands shall be free from activities that would substantially impair the biological community as it naturally occurs due to physical, chemical, and hydrologic processes.

5.1.2.10. **Oil and Grease.** Waters must not contain oils, greases, waxes, or other materials in concentrations that result in a visible film or coating on the surface of the water or on objects in the water, that cause nuisance, or that otherwise adversely affect the water for beneficial uses. For natural high quality waters, the concentration of oils, greases, or other film or coat generating substances shall not be altered.

5.1.2.11. **pH.** In fresh waters with designated beneficial uses of COLD or WARM, changes in normal ambient pH levels must not exceed 0.5 pH units. The pH must not be depressed below 6.5 nor raised above 8.5.

The Lahontan Water Board recognizes that some waters of the Region may have natural pH levels outside of the 6.5 to 8.5 range. Compliance with the pH objective for these waters will be determined on a case-by-case basis.

5.1.2.12. **Radioactivity.** Radionuclides shall not be present in concentrations that are deleterious to human, plant, animal, or aquatic life or that result in the accumulation of radionuclides in the food web to an extent that presents a hazard to human, plant, animal, or aquatic life. Waters designated as MUN shall not contain concentrations of radionuclides in excess of the limits specified in sections 64443 (Radioactivity) and section 64442 of Title 22 of the California Code of Regulations, which is incorporated by reference into this Order. This incorporation-by-reference is prospective including future changes to the incorporated provisions as changes take effect.

5.1.2.13. **Sediment.** The suspended sediment load and suspended sediment discharge rate of surface waters must not be altered in such a manner as to cause nuisance or adversely affect the water for beneficial uses.

5.1.2.14. **Settleable Materials.** Waters must not contain substances in concentrations that result in deposition of material that causes nuisance or that adversely affects the water for beneficial uses. For natural high quality waters, the concentration of settleable materials must not be raised by more than 0.1 ml/L.

5.1.2.15. **Suspended Material.** Waters must not contain suspended materials in concentrations that cause nuisance or that adversely affect the water for beneficial uses. For natural high quality waters, the concentration of total suspended materials must not be altered to the extent that such alterations are discernible at the 10 percent significance level.

5.1.2.16. **Taste and Odor.** Waters must not contain taste or odor-producing substances in concentrations that impart undesirable tastes or odors to fish or other edible products of aquatic origin, that cause nuisance, or that adversely affect the water for beneficial uses. For naturally high quality waters, the taste and odor must not be altered.

5.1.2.17. **Temperature.** The natural receiving water temperature of all waters must not be altered unless it can be demonstrated to the satisfaction of the Lahontan Water Board that such an alteration in temperature does not adversely affect the water for beneficial uses. For waters designated WARM, water temperature must not be altered by more than 5 degrees Fahrenheit (5°F) above or below the natural temperature. For waters designated COLD, the temperature must not be altered.

[Note: The Basin Plan Amendment specifies the reach of the Mojave River which the Facility discharges to as a COLD and WARM beneficial use. Therefore, the most restrictive standard (i.e., no alteration of temperature for the COLD use) applies. However, for purposes of compliance and enforcement, the Lahontan Water Board will consider historical data and the impact of temperature alterations upon the beneficial uses of the Mojave River below Discharge Point 001.]

5.1.2.18. **Toxicity.** All waters must be maintained free of toxic substances in concentrations that are toxic to, or that produce detrimental physiological responses in human, plant, animal, or aquatic life. Compliance with this objective will be determined by use of indicator organisms. The Lahontan Water Board has selected ceriodaphnia dubia to be considered as the sensitive indicator species for both acute and chronic toxicity.

Ceriodaphnia dubia testing must follow the method identified in Code of Federal Regulations, title 40, part 136 or, for acute toxicity, Measuring the Acute Toxicity of Effluents and Receiving Waters to Freshwater and Marine Organisms, Fifth Edition (EPA-821-R-02-012) or, for chronic toxicity, Short-term Methods for Estimating the Chronic Toxicity of Effluents and Receiving Waters to Freshwater Organisms, Fourth Edition (EPA-821-R-02-013). The regulatory decision will be based on the test results in comparison to controls using the respective information below for acute and chronic toxicity.

5.1.2.18.1 **Acute Toxicity.** The acute aquatic toxicity water quality objective is expressed as a null hypothesis and an alternative hypothesis with a regulatory management decision (RMD) of 0.80, where the following null hypothesis,  $H_0$ , shall be used:

$H_0$ : Mean response (ambient water)  $\leq$  0.80 • mean response (control)

And where the following alternative hypothesis,  $H_a$ , shall be used:

$H_a$ : Mean response (ambient water)  $>$  0.80 • mean response (control)

Attainment of the water quality objective is demonstrated by conducting acute aquatic toxicity testing and rejecting this null hypothesis in accordance with the TST statistical approach. When the null hypothesis is rejected, the alternative hypothesis is accepted in its place, and there is no exceedance of the acute aquatic toxicity water quality objective. Failing to reject the null hypothesis (referred to as a “fail”) is equivalent to an exceedance of the acute aquatic toxicity water quality objective.

5.1.2.18.2 **Chronic Toxicity.** The chronic aquatic toxicity water quality objective is expressed as a null hypothesis and an alternative hypothesis with a regulatory management decision (RMD) of 0.75, where the following null hypothesis,  $H_0$ , shall be used:

$H_0$ : Mean response (ambient water)  $\leq$  0.75 • mean response (control)

And where the following alternative hypothesis,  $H_a$ , shall be used:

$H_a$ : Mean response (ambient water)  $>$  0.75 • mean response (control)

Attainment of the water quality objective is demonstrated by conducting chronic aquatic toxicity testing and rejecting this null hypothesis in accordance with the Test of Significant Toxicity (TST) statistical approach described in the Statewide Toxicity Provisions Section IV.B.1.c. When the null hypothesis is rejected, the alternative hypothesis is accepted in its place, and there is no exceedance of the chronic aquatic toxicity water quality objective. Failing to reject the null hypothesis (referred to as a “fail”) is equivalent to an exceedance of the chronic aquatic toxicity water quality objective.

5.1.2.19. **Turbidity.** Waters must be free of changes in turbidity that cause nuisance or adversely affect the water for beneficial uses. Increases in turbidity must not exceed natural levels by more than 10 percent.

5.1.2.20. **Specific Numeric Receiving Water Limitations.** Surface receiving water limitations for the Mojave River at the Lower Narrows and at Victorville in Table 6 are based on Tables 3-20 and 3-21 (pages 3-54 and 3-56 through 3-57) of the Basin Plan. These limitations apply to surface waters tributary to the Mojave River above the Lower Narrows and to the shallow groundwater in the vicinity of and beneath the Mojave River channel. Discharges from the Facility must not cause or contribute to exceedances of the following limitations:

**Table 3. Surface Water Limitations (mg/L)**

<b>Constituent</b>	<b>Annual Average</b>	<b>90<sup>th</sup> Percentile</b>	<b>Instantaneous Maximum</b>
Total Dissolved Solids (TDS)	-	-	312
Nitrate (NO <sub>3</sub> ) as Nitrate-Nitrogen	-	-	5
Chloride	75	100	-
Sulfate	40	100	-
Fluoride	0.2	1.5	-
Boron	0.2	0.3	-

**5.2. Groundwater Limitations**

5.2.1. Shallow groundwater adjacent to the Mojave River is highly influenced by the river. As such, the limitations for this shallow groundwater are the same as those in section 5.1., above.

**6. PROVISIONS**

**6.1. Standard Provisions**

6.1.1. The Discharger must comply with all Standard Provisions included in Attachment D.

6.1.2. The Discharger must comply with the following provisions. In the event that there is any conflict, duplication, or overlap between provisions specified by this Order, the more stringent provision shall apply:

6.1.2.1. Surface waters as used in this Order include, but are not limited to, wetlands and live streams, either perennial or ephemeral, which flow in natural or artificial watercourses, and natural lakes and artificial impoundments of waters within the State of California.

6.1.2.2. Groundwaters as used in this Order include, but are not limited to, all subsurface waters being above atmospheric pressure, and the capillary fringe of these waters.

6.1.2.3. The requirements prescribed herein do not authorize the commission of any act causing injury to the property of another, nor protect the Discharger from liabilities under federal, state, or local laws, nor guarantee the Discharger a capacity right in the receiving waters.

6.1.2.4. All discharges authorized by this Order must be consistent with the terms and conditions of this Order. The discharge of any pollutant more frequently than, or

at a level in excess of, that identified and authorized by this Order shall constitute a violation of the terms and conditions of this Order.

- 6.1.2.5. Pursuant to Water Code section 13263, subdivision (g), no discharge of waste into the waters of the state, whether or not the discharge is made pursuant to waste discharge requirements, shall create a vested right to continue the discharge. All discharges of waste into waters of the state are privileges, not rights.
- 6.1.2.6. Failure to comply with this permit may constitute a violation of the Water Code and/ or the CWA and is grounds for enforcement action or for permit termination, revocation and re-issuance, or modification.
- 6.1.2.7 The Discharger must take all reasonable steps to minimize or prevent any discharge in violation of this permit that has a reasonable likelihood of adversely affecting human health or the environment.
- 6.1.2.8. The Water Code and the CWA provide for civil liability and criminal penalties for violations of the permit limits including imposition of civil liability or referral to the Attorney General.
- 6.1.2.9. A copy of the NPDES permit must be kept and maintained by the Discharger and be available at all times to operating personnel.
- 6.1.2.10. Provisions of the permit are severable. If any provision of the requirements is found invalid, the remainder of the requirements shall not be affected.
- 6.1.2.11. In the event the Discharger is unable to comply with any of the conditions of this Order due to:
  - 6.1.2.11.1. breakdown or serious malfunction of water treatment equipment;
  - 6.1.2.11.2. accidents caused by human error or negligence;
  - 6.1.2.11.3. overflows from the system; or
  - 6.1.2.11.4. other causes such as acts of nature,the Discharger must notify the Lahontan Water Board Executive Officer as soon as the Discharger or the Discharger's agents have knowledge of any discharge in violation of this permit, or any emergency discharge or other discharge of water to the Mojave River or surrounding wetland areas, in accordance with the notification requirements in the Standard Provisions for NPDES Permits, included in this Order as Attachment D, and with Water Code sections 13267 and 13383.
- 6.1.2.12. Pursuant to Water Code section 13267, subdivision (b), the Discharger must notify the Lahontan Water Board of any substantial change in the volume or character of pollutants introduced into the Facility from the conditions existing at the time of adoption of this NPDES permit.
- 6.1.2.13. Adequate notice must include information on the quality and quantity of effluent discharged into the receiving waters for the Facility, as well as any

anticipated impact of the change on the quantity or quality of the effluent to be discharged from the Facility. A substantial change in volume is considered an increase in excess of ten percent of the mean daily flow rate. The Discharger must forward a copy of such notice directly to the USEPA Regional Administrator.

- 6.1.2.14. The Discharger must file a report of waste discharge with the Lahontan Water Board at least 180 days before making any material change or proposed change in the character, location, or volume of the discharge.
- 6.1.2.15. Pursuant to Water Code section 13260, subdivision (c), any change in the ownership and/or operation of property subject to the NPDES permit must be reported to the Lahontan Water Board. Notification of applicable NPDES Permit requirements must be furnished in writing to the new owners and/or operators, and a copy of such notification must be sent to the Lahontan Water Board. 4
- 6.1.2.16. If a Discharger becomes aware that any information submitted to the Lahontan Water Board is incorrect, the Discharger must immediately notify the Lahontan Water Board, in writing, and correct that information.
- 6.1.2.17. Failure to comply with provisions or requirements of this Order, or violation of other applicable laws or regulations governing discharges from this facility, may subject the Discharger to administrative or civil liabilities, criminal penalties, and/or other enforcement remedies to ensure compliance. Additionally, certain violations may subject the Discharger to civil or criminal enforcement from appropriate local, state, or federal law enforcement entities.
- 6.1.2.18. In the event the Discharger does not comply or will be unable to comply for any reason, with any prohibition, maximum daily effluent limitation, average monthly effluent limitation, or receiving water limitation of this Order, the Discharger must notify the Lahontan Water Board by telephone [(530) 542-5400] within 24 hours of having knowledge of such noncompliance, and must confirm this notification in writing within five days, unless the Lahontan Water Board waives confirmation. The written notification must state the nature, time, duration, and cause of noncompliance, and must describe the measures being taken to remedy the current noncompliance and prevent recurrence including, where applicable, a schedule of implementation. Other noncompliance requires written notification as above at the time of the normal monitoring report.
- 6.1.2.19. Unless specifically granted in writing, authorization pursuant to this Order does not constitute an exemption to applicable discharge prohibitions in the Basin Plan.
- 6.1.2.20. Reports required by this Order, and other information requested by the Lahontan Water Board, must be signed by a duly-authorized representative of the Discharger. Under Water Code sections 13268 and 13383, any person failing or refusing to furnish technical or monitoring reports or falsifying any information provided therein, is guilty of a misdemeanor and may be liable civilly in an amount of up to ten thousand dollars (\$10,000) for each violation.

## 6.2. Monitoring and Reporting Program (MRP) Requirements

The Discharger must comply with the MRP, and future revisions thereto, in Attachment E.

## 6.3. Special Provisions

### 6.3.1. Reopener Provisions

6.3.1.1. If more stringent applicable water quality standards are promulgated or approved pursuant to section 303 of the Federal Water Pollution Control Act or amendments thereto, the Lahontan Water Board may revise and modify this Order in accordance with such more stringent standards.

6.3.1.2. **Effluent Limitations Based on New Information.** If after review of new data and information regarding aquatic toxicity testing, information collected as specified below in section 6.3.2. of this Order, monitoring for constituents listed in Basin Plan Table 3-20 (Page 3-54), or the drug and chemical use reporting required in the MRP (Attachment E) indicate any monitored parameter, drug, or chemical is, or may be, discharged at a level that will cause, have the reasonable potential to cause, or contribute to an in-stream excursion above any chemical-specific water quality criteria or objective, or contribute to an excursion of the numeric Water Quality Objectives or narrative Water Quality Objectives contained in the Basin Plan for the Mojave River, or violate any narrative water quality objective for chemical constituents from the Basin Plan, or narrative water quality objective for toxicity from the Basin Plan, this Order may be reopened to establish effluent limitations.

6.3.1.3. **Toxicity Test Exposure Times.** Chemical specific concentrations of toxicity, as specified in section 6.3.2.1.7. of this Order, are based on exposure times of 48 or 96 hours and for potassium permanganate the 2 hour No Observed Effect Concentration (NOEC). If the Discharger provides sufficient justification that shorter exposure times are a closer approximation of actual exposure times, then this Order may be reopened to account for shorter exposure times. For future hatchery permits, for all drugs and chemicals, the 2 hour NOEC may be used when applicable, as CDFW hatcheries have reported to apply drugs and chemicals in 1 hour dosages.

6.3.1.5. **Intake Water Credits.** The Discharger submitted information as detailed in section 1.4.4 of the SIP demonstrating that the required conditions are met for intake water credits. As the SIP conditions were met, the Lahontan Water Board included effluent limitations based on the 99th percentile value representing the upper range of the variability between intake and effluent pollutant concentrations due to sampling and analysis variability. To the extent that the characteristics of the influent (and subsequently the effluent) change, the effluent limitations specified in this Order may be modified if new information is submitted by the Discharger to the Lahontan Water Board.

### 6.3.2. Special Studies, Technical Papers and Additional Monitoring Requirements



### 6.3.2.1. Chemical and Aquaculture Drug Use

Attachment G of this Order lists all aquaculture drugs and chemicals that may potentially be used at the Facility, as well as expected application methods and dosages. This Order authorizes the discharge of acetic acid, amoxicillin trihydrate, carbon dioxide, Chloramine-T, Chorulon®, Epsom salt, erythromycin, enteric redmouth vaccine, florfenicol, formalin, hydrogen peroxide, ivermectin, MS-222, Ovaplant®, oxytetracycline dihydrate, oxytetracycline hydrochloride, penicillin G potassium, potassium permanganate, PVP Iodine, SLICE, sodium bicarbonate, sodium chloride, Romet-30®, and Vibrio vaccine in accordance with label directions, effluent limitations, BMP Plan requirements, monitoring and reporting requirements and other conditions of this Order.

Other aquaculture chemicals or drugs that may be used at the Facility can only be authorized if the Discharger notifies the Lahontan Water Board in writing of the intent to use a new drug or chemical. The notification must contain the following supplemental information:

- 6.3.2.1.1. The common name(s) and active ingredient(s) of the drug or chemical proposed for use and discharge.
- 6.3.2.1.2. The purpose for the proposed use of the drug or chemical (i.e., list the specific disease for treatment and specific species for treatment).
- 6.3.2.1.3. The amount proposed for use or disposal, and the resulting calculated estimate of concentration in the discharge. Calculations used to derive estimated concentrations must also be submitted.
- 6.3.2.1.4. The location, duration, and frequency of the proposed use or disposal.
- 6.3.2.1.5. Safety Data Sheets and available toxicity information.
- 6.3.2.1.6. Any related Investigational New Animal Drug (INAD), New Animal Drug Application (NADA) information, extra-label use requirements and/or veterinarian prescriptions.
- 6.3.2.1.7. The Discharger must also submit acute toxicity test information on any new chemical or drug applied in solution for immersive treatment in accordance with methods specified in the U.S. EPA Methods for Measuring the Acute Toxicity of Effluents and Receiving Waters to Freshwater and Marine Organisms (EPA 600/4-90/027) using *Ceriodaphnia dubia* (*C. dubia*) to determine the No Observed Adverse Effect Level (NOAEL) and Lowest Observed Adverse Effect Level (LOAEL).

Where exposure of aquatic life to any aquaculture drug or chemical may be long-term or continuous, the Discharger also must conduct and/or submit the results of chronic toxicity testing for that chemical in accordance with the U.S. EPA *Short-Term Methods for Estimating the Chronic Toxicity of Effluents and Receiving Waters to Freshwater Organisms, Fourth Edition, October 2002* (EPA-821-R-02-013), using *C. dubia*, to determine the NOEC or Inhibition Concentration (IC25).

The Discharger must not use other aquaculture drugs or chemicals until notified in writing by the Lahontan Water Board that the notification requirements specified in this provision have been satisfied and the request for a proposed chemical use has been approved. The Lahontan Water Board may reopen this Order to establish appropriate waste discharge requirements for new proposed chemical uses after notice to the Discharger and the public, as may be required.

#### **6.3.2.2. Reporting of Unanticipated Discharges**

6.3.2.2.1. The Discharger must provide to the Lahontan Water Board an oral report within 24 hours of discovery of the failure in, or damage to, a settling pond (effluent treatment system) or an aquatic animal containment system resulting in an unanticipated material discharge of pollutants to waters of the United States or state. The Discharger must describe the cause of the failure or damage to the containment system and identify materials that have been released to the environment as a result of this failure/damage.

6.3.2.2.2. The Discharger must provide a written report within seven (7) days of discovery of the failure or damage, documenting the cause, the estimated time that elapsed before the failure or damage was repaired, an estimate of the material released as a result of the failure or damage, and steps being taken to prevent a recurrence.

6.3.2.2.3. In the event of a spill of drugs, chemicals, pesticides, or feed that results in a discharge to waters of the United States or state, the Discharger must provide an oral report of the spill to the Lahontan Water Board within 24 hours of discovery of its occurrence and a written report within seven (7) days. The report must include the identity and quantity of the material spilled.

#### **6.3.3. Best Management Practices and Pollution Prevention**

##### **6.3.3.1. Best Management Practices (BMP) Plan – Aquaculture Operations**

The Discharger must certify in writing to the Lahontan Water Board no later than **180 days after the adoption date** that the BMP Plan has been updated to include the requirements specified in this Order and is being implemented as required by 40 C.F.R. section 451.3(d). The existing BMP Plan may be modified for use under this section. The Discharger must develop and implement the BMP Plan to prevent or minimize the generation and discharge of wastes and pollutants to waters of the United States and State and ensure disposal or land application of wastes is in compliance with applicable solid waste disposal regulations. The Discharger must consider the recommendations provided in USEPA's March 2006 Compliance Guide for the Concentrated Aquatic Animal Production Point Source Category (EPA-821-B-05-001) when updating the BMP Plan. The Discharger must review and certify in writing to the Lahontan Water Board the BMP Plan annually (by **February 1** of each year) and must amend the BMP Plan whenever there is a change in the Facility or in the

operation of the Facility which materially increases the generation of pollutants or their release or potential release to surface waters.

The BMP plan must include, at a minimum, the following BMPs:

**6.3.3.1.1. Solids Management**

- 6.3.3.1.1.1. Conduct fish feeding in a manner that limits feed input to the minimum amount reasonably necessary to achieve production goals and sustain targeted rates of aquatic animal growth and minimizes the discharge of unconsumed food and waste products to surface waters.
- 6.3.3.1.1.2. Clean aquaculture raceways and settling pond using procedures and at frequencies that minimize the disturbance and subsequent discharge of accumulated solids during routine activities such as inventorying, grading, and harvesting. Include procedures to remove bryozoans using hydrogen peroxide. The procedures must ensure there is no discharge of hydrogen peroxide, bryozoans, or solid matter.
- 6.3.3.1.1.3. Report the final disposition of all other solids and liquids, including aquaculture drugs and chemicals, not discharged to surface waters in the effluent.
- 6.3.3.1.1.4. Remove and properly dispose of fish mortalities on a regular basis to prevent discharge to waters of the United States, except in cases where the discharge to surface waters is determined to benefit the aquatic environment. Procedures must be identified and implemented to collect, store, and dispose of fish and other solid wastes in an environmentally safe manner and in a manner so as to minimize discharge to waters of the United States or waters of the State.

**6.3.3.1.2. Operations and Maintenance**

- 6.3.3.1.2.1. Maintain the Facility to prevent the overflow of any floating matter or bypassing of the settling pond.
- 6.3.3.1.2.2. Inspect the Facility and the settling pond on a routine basis in order to identify and promptly repair any damage.
- 6.3.3.1.2.3. Ensure storage and containment of drugs, chemicals, fuel, waste oil, organic wastes, pesticides/biocides/herbicides, or other materials to prevent spillage or release into the Facility, waters of the United States, or waters of the State.
- 6.3.3.1.2.4. Implement procedures for properly containing, cleaning, and disposing of any spilled material.
- 6.3.3.1.2.5. Prevent fish from being released within the U.S. Food and Drug Administration (FDA) required withdrawal time of any drug or chemical with which they have been treated.

6.3.3.1.2.6. All drugs and pesticides must be used in accordance with applicable label directions (FIFRA or FDA), except under the following conditions, both of which must be reported in advance to the Executive Officer:

6.3.3.1.2.6.1. Participation in Investigational New Animal Drug (INAD) studies, using established protocols; or

6.3.3.1.2.6.2. Extra label drug use, as prescribed by a veterinarian.

6.3.3.1.2.7. Implement protocols to ensure that pesticides stored or used on site will not spill, drift, or transport by storm water into the discharge, into waters of the United States, or into waters of the State.

6.3.3.1.2.8. Limit the number of raceways treated during chemical treatments to ensure compliance with effluent limitations and provisions of this Order.

6.3.3.1.2.9. Only one raceway at a time may be treated with potassium permanganate.

#### 6.3.3.1.3. **Recordkeeping**

6.3.3.1.3.1. Maintain records for aquatic animal rearing units documenting the feed amounts and estimates of the numbers and weight of aquatic animals in order to calculate representative feed conversion ratios using the Feed Conversion Ratios Log provided in Attachment K of this Order.

6.3.3.1.3.2. Maintain records documenting the frequency of cleaning, inspections, maintenance, repairs, spills, and spill response.

6.3.3.1.3.3. Maintain records documenting compliance with training requirements.

#### 6.3.3.1.4. **Training**

6.3.3.1.4.1. Adequately train all relevant Facility personnel in spill prevention and how to respond in the event of a spill in order to ensure the proper clean-up and disposal of spilled material.

6.3.3.1.4.2. Train staff on the proper operation and cleaning of production and wastewater treatment systems, including training in feeding procedures and proper use of equipment.

6.3.3.1.4.3. The Discharger must ensure that its operations staff are familiar with the BMP Plan and have been adequately trained in the specific procedures it requires.

#### 6.3.3.2. **Storm Water Pollution Prevention Plan (SWPPP)**

Storm water runoff and infiltration of storm water at the Facility has the potential to come in contact with pollutants directly associated with aquaculture activities and secondary activities such as, but not limited to: vehicle maintenance, transportation of fish, construction, maintenance of structures on the Facility, or outdoor storage of unused or salvaged items. Pollutants that may come in contact with storm water and discharge to waters of the State in runoff or infiltration to groundwater include, but are not limited to, chemicals, fuel, waste oil, vehicle wash water, cleaning solutions, landscaping supplies, landscaping

wastes, and storage of other materials with the potential for discharge to surface waters. The Discharger must develop and implement in accordance with the requirements in Attachment I, a SWPPP that describes site-specific BMPs for minimizing contamination of storm water runoff and for preventing contaminated storm water runoff from being discharged directly to waters of the State. The SWPPP must be reviewed at least annually, in accordance with Attachment I, and updated to represent current site conditions. The SWPPP must also address the control of non-storm water discharges to the storm drainage system and the control measures needed to meet applicable prohibitions and requirements.

#### **6.3.4. Construction, Operation and Maintenance Specifications**

- 6.3.4.1. Collected screenings, sludges, and other solids, including fish carcasses, must be disposed of in a manner approved by the Lahontan Water Board staff and consistent with Consolidated Regulations for Treatment, Storage, Processing, or Disposal of Solid Waste, as set forth in Title 27, CCR, Division 2, Subdivision 1, Section 20005, et seq.
- 6.3.4.2. All aquaculture drugs and chemicals not discharged to receiving waters in accordance with the provisions of this Order must be disposed of in an environmentally safe manner, according to label guidelines, Material Safety Data Sheet guidelines and the Discharger's BMP Plan (see Section 7.3.3.1 of this Order). Any other form of disposal requires approval from the Executive Officer. For all aquaculture drugs and chemicals not authorized for discharge to receiving waters, the disposal onto permeable ground, or in any manner or in quantities that may result in a discharge to surface water or to groundwater, is prohibited (see also Section 3, Discharge Prohibitions).
- 6.3.4.3. All facilities used for transport and treatment of hatchery wastewater must be adequately protected against either structural damage or significant reduction in efficiency resulting from a storm or flood having a recurrence interval of once in 100 years.
- 6.3.4.4. Solid waste, including fish mortalities, must be discharged only at a legal point of disposal in accordance or in a manner approved by the Executive Officer.
- 6.3.4.5. The vertical distance between the water surface elevation and the lowest point of a pond dike or the invert of an overflow structure must not be less than 2 feet (0.46 meters).
- 6.3.4.6. This Order authorizes the Discharger to discharge up to 1,000 gallons of recirculated water from the recirculated water aeration tower to the adjacent drainage ditch no more than once every 12 months. The Discharger must ensure drainage of the aeration tower occurs during dry weather conditions in a manner that ensures percolation within 100 feet and minimizes erosion within the drainage channel. The Discharger must report the date(s) when drainage occurs and the total volume of drainage water discharged in the Annual Report.

**6.3.5. Special Provisions for Publicly-Owned Treatment Works (POTWs) – Not Applicable**

**6.3.6. Other Special Provisions**

**6.3.6.1. Storm Water Runoff and Storm Water Collection Systems Provisions**

6.3.6.1.1. This Order does not supersede any obligation to obtain and maintain coverage under the General Order for Discharges of Storm Water Associated with Construction Activity (Construction General Order) or any other permit when such permits are applicable.

6.3.6.1.2. The State Water Board's Water Quality Order 2014-0057-DWQ, General Order for Storm Water Discharges Associated with Industrial Activities (NPDES General Order No. CAS000001) (Industrial General Order) does not regulate storm water discharges from concentrated aquatic animal production (CAAP) facilities/fish hatcheries. Nevertheless, the Lahontan Water Board finds that industrial wastes in storm water runoff from CAAP facilities/fish hatcheries may impact water quality. Therefore, this Order includes substantive requirements applicable to the Industrial General Order.

6.3.6.1.3. Unless authorized by a separate NPDES Permit or WDR, storage and use of materials not designated for outdoor use must be protected from exposure to storm water.

6.3.6.1.4. Liquids and solutes that may spill, leak, or leach from materials and or equipment used in the Facility must be protected from exposure to storm water.

**6.3.7. Compliance Schedules – Not Applicable**

**7. COMPLIANCE DETERMINATION**

Compliance with the effluent limitations contained in section 4 of this Order will be determined as specified below:

**7.1. Multiple Sample Data**

When determining compliance with an average monthly effluent limitation (AMEL) or MDEL and more than one sample result is available, the Discharger must compute the arithmetic mean unless the data set contains one or more reported determinations of "Detected, but Not Quantified" (DNQ) or "Not Detected" (ND). In those cases, the Discharger must compute the median in place of the arithmetic mean in accordance with the following procedure:

7.1.1. The data set must be ranked from low to high, ranking the reported ND determinations lowest, DNQ determinations next, followed by quantified values (if any). The order of the individual ND or DNQ determinations is unimportant.

7.1.2. The median value of the data set must be determined. If the data set has an odd number of data points, then the median is the middle value. If the data set has an even number of data points, then the median is the average of the two values around the middle unless one or both of the points are ND or DNQ, in which case

the median value must be the lower of the two data points where DNQ is lower than a value and ND is lower than DNQ.

## **7.2. Limitation Bases**

### **7.2.1. Average Monthly Effluent Limitation (AMEL)**

If the average of daily discharges over a calendar month exceeds the AMEL for a given parameter, this will represent a single violation, though the Discharger will be considered out of compliance for each day of that month for that parameter (e.g., resulting in 31 days of noncompliance in a 31-day month). If only a single sample is taken during the calendar month and the analytical result for that sample exceeds the AMEL, the Discharger will be considered out of compliance for that calendar month. The Discharger will only be considered out of compliance for days when the discharge occurs. For any one calendar month during which no sample (daily discharge) is taken, no compliance determination can be made for that calendar month. The Discharger will calculate and report the net effluent over influent concentration as necessary for TSS. Additional samples, above specified minimum, may be collected to demonstrate compliance.

### **7.2.2. Maximum Daily Effluent Limitation (MDEL)**

If a daily discharge exceeds the MDEL for a given parameter, the Discharger will be considered out of compliance for that parameter for that one day only within the reporting period. For any one day during which no sample is taken, no compliance determination can be made for that calendar day.

### **7.2.3. Instantaneous Minimum Effluent Limitation**

If the analytical result of a single grab sample is lower than the instantaneous minimum effluent limitation for a parameter, the Discharger will be considered out of compliance for that parameter for that single sample. Non-compliance for each sample will be considered separately (e.g., the results of two grab samples taken at different times within a calendar day that both are lower than the instantaneous minimum effluent limitation would result in two instances of non-compliance with the instantaneous minimum effluent limitation). Duplicate samples taken at the same time and location for QA/QC purposes will not be subject to duplicate fines. QA/QC includes splitting a sample and/or collection of duplicate samples for analysis by a different laboratory. Reanalysis of samples after re-calibration and maintenance of field test instruments will not be subject to duplicate fines.

### **7.2.4. Instantaneous Maximum Effluent Limitation**

If the analytical result of a single grab sample is higher than the instantaneous maximum effluent limitation for a parameter, the Discharger will be considered out of compliance for that parameter for that single sample, except for pH. For pH, if the source groundwater pH equals or exceeds the instantaneous maximum effluent limitation, then the effluent pH of the corresponding discharge point may not exceed the groundwater pH by more than 0.5 standard units for that sampling

event only. For example, if the pH of INF-001 is 8.6 standard units, then the pH of EFF-001 may not exceed 9.1 standard units for that particular sampling event.

Noncompliance for each sample will be considered separately (e.g., the results of two grab samples taken different times within a calendar day that both exceed the instantaneous maximum effluent limitation would result in two instances of noncompliance with the instantaneous maximum effluent limitation). Duplicate samples taken at the same time and location for QA/QC purposes will not be subject to duplicate fines. QA/QC includes splitting a sample and/or collection of duplicate samples for analysis by a different laboratory. Reanalysis of samples after re-calibration and maintenance of field test instruments will not be subject to duplicate fines. The Discharger will calculate and report whether the influent supply water concentration equals or exceeds the instantaneous maximum effluent limitation.



## ATTACHMENT A – DEFINITIONS

### **Arithmetic Mean ( $\mu$ )**

Also called the average, is the sum of measured values divided by the number of samples. For ambient water concentrations, the arithmetic mean is calculated as follows:

$$\text{Arithmetic mean } (\mu) = \frac{\sum x}{n}$$

where:  $\sum x$  is the sum of the measured ambient water concentrations, and  $n$  is the number of samples.

### **Aquaculture Facility**

A hatchery, fish farm, or other facility that contains, grows, or holds fish for later harvest (or process) and for sale or releases.

### **Average Monthly Effluent Limitation (AMEL)**

The highest allowable average of daily discharges over a calendar month, calculated as the sum of all daily discharges measured during a calendar month divided by the number of daily discharges measured during that month.

### **Average Weekly Effluent Limitation (AWEL)**

The highest allowable average of daily discharges over a calendar week (Sunday through Saturday), calculated as the sum of all daily discharges measured during a calendar week divided by the number of daily discharges measured during that week.

### **Best Management Practices (BMPs)**

Schedules of activities, prohibitions of practices, maintenance procedures, and other management practices to prevent or reduce the pollution of surface waters. BMPs also include treatment requirements, operating procedures, and practices to control site runoff, spillage or leaks, and solids or waste disposal.

### **Bioaccumulative**

Those substances taken up by an organism from its surrounding medium through gill membranes, epithelial tissue, or from food and subsequently concentrated and retained in the body of the organism.

### **Carcinogenic**

Pollutants are substances that are known to cause cancer in living organisms.

### **Coefficient of Variation (CV)**

CV is a measure of the data variability and is calculated as the estimated standard deviation divided by the arithmetic mean of the observed values.

### **Cold Water Species**

Cold water aquatic animals include, but are not limited to, the Salmonidae family of fish, e.g., trout and salmon.

### **Concentrated Aquatic Animal Production (CAAP) Facility**

Point Sources subject to the National Pollutant Discharge Elimination System (NPDES) permit program including those upland facilities that discharge for at least 30 days per year and contain, grow, or hold cold water fish species or other cold water aquatic animals except facilities which produce less than 9,000 harvest weight kilograms (approximately 20,000 pounds) of aquatic animals per year and facilities which feed less than 2,285 kilograms (approximately 5,000 pounds) of food during the calendar month of maximum feeding.

### **Daily Discharge**

Daily Discharge is defined as either: (1) the total mass of the constituent discharged over the calendar day (12:00 am through 11:59 pm) or any 24-hour period that reasonably represents a calendar day for purposes of sampling (as specified in the permit), for a constituent with limitations expressed in units of mass or; (2) the unweighted arithmetic mean measurement of the constituent over the day for a constituent with limitations expressed in other units of measurement (e.g., concentration).

The daily discharge may be determined by the analytical results of a composite sample taken over the course of one day (a calendar day or other 24-hour period defined as a day) or by the arithmetic mean of analytical results from one or more grab samples taken over the course of the day.

For composite sampling, if 1 day is defined as a 24-hour period other than a calendar day, the analytical result for the 24-hour period will be considered as the result for the calendar day in which the 24-hour period ends.

### **Detected, but Not Quantified (DNQ)**

DNQ are those sample results less than the RL, but greater than or equal to the laboratory's MDL. Sample results reported as DNQ are estimated concentrations.

### **Dilution Credit**

Dilution Credit is the amount of dilution granted to a discharge in the calculation of a water quality-based effluent limitation, based on the allowance of a specified mixing zone. It is calculated from the dilution ratio or determined through conducting a mixing zone study or modeling of the discharge and receiving water.

### **Effluent Concentration Allowance (ECA)**

ECA is a value derived from the water quality criterion/objective, dilution credit, and ambient background concentration that is used, in conjunction with the coefficient of variation for the effluent monitoring data, to calculate a long-term average (LTA) discharge concentration. The ECA has the same meaning as wasteload allocation

(WLA) as used in U.S. EPA guidance (Technical Support Document For Water Quality-based Toxics Control, March 1991, second printing, EPA/505/2-90-001).

### **Enclosed Bays**

Enclosed Bays means indentations along the coast that enclose an area of oceanic water within distinct headlands or harbor works. Enclosed bays include all bays where the narrowest distance between the headlands or outermost harbor works is less than 75 percent of the greatest dimension of the enclosed portion of the bay. Enclosed bays include, but are not limited to, Humboldt Bay, Bodega Harbor, Tomales Bay, Drake's Estero, San Francisco Bay, Morro Bay, Los Angeles-Long Beach Harbor, Upper and Lower Newport Bay, Mission Bay, and San Diego Bay. Enclosed bays do not include inland surface waters or ocean waters.

### **Estimated Chemical Concentration**

The estimated chemical concentration that results from the confirmed detection of the substance by the analytical method below the ML value.

### **Estuaries**

Estuaries means waters, including coastal lagoons, located at the mouths of streams that serve as areas of mixing for fresh and ocean waters. Coastal lagoons and mouths of streams that are temporarily separated from the ocean by sandbars shall be considered estuaries. Estuarine waters must be considered to extend from a bay or the open ocean to a point upstream where there is no significant mixing of fresh water and seawater. Estuarine waters included, but are not limited to, the Sacramento-San Joaquin Delta, as defined in Water Code section 12220, Suisun Bay, Carquinez Strait downstream to the Carquinez Bridge, and appropriate areas of the Smith, Mad, Eel, Noyo, Russian, Klamath, San Diego, and Otay rivers. Estuaries do not include inland surface waters or ocean waters.

### **Extra Label Drug Use**

A drug approved under the Federal Food, Drug, and Cosmetic Act that is not used in accordance with the approved label directions (see 21 C.F.R. part 530).

### **Inland Surface Waters**

All surface waters of the state that do not include the ocean, enclosed bays, or estuaries.

### **Instantaneous Maximum Effluent Limitation**

The highest allowable value for any single grab sample or aliquot (i.e., each grab sample or aliquot is independently compared to the instantaneous maximum limitation).

### **Instantaneous Minimum Effluent Limitation**

The lowest allowable value for any single grab sample or aliquot (i.e., each grab sample or aliquot is independently compared to the instantaneous minimum limitation).

### **Investigational New Animal Drug (INAD)**

A drug for which there is a valid exemption in effect under section 512(j) of the Federal Food, Drug, and Cosmetic Act, 21 U.S.C. 360(j), to conduct experiments.

### **Maximum Daily Effluent Limitation (MDEL)**

The highest allowable daily discharge of a pollutant, over a calendar day (or 24-hour period). For pollutants with limitations expressed in units of mass, the daily discharge is calculated as the total mass of the pollutant discharged over the day. For pollutants with limitations expressed in other units of measurement, the daily discharge is calculated as the arithmetic mean measurement of the pollutant over the day.

### **Median**

The middle measurement in a set of data. The median of a set of data is found by first arranging the measurements in order of magnitude (either increasing or decreasing order)

**If the number of measurements (n) is odd, then:**

$$\text{median} = \frac{X_{(n+1)}}{2}$$

**If n is even, then:**

$$\text{median} = \frac{\frac{X_n}{2} + \frac{X_{n+1}}{2}}{2}$$

(i.e., the midpoint between the (n/2 and ((n/2)+1))).

### **Method Detection Limit (MDL)**

MDL is the minimum concentration of a substance that can be reported with 99 percent confidence that the measured concentration is distinguishable from method blank results, as defined in 40 Code of Federal Regulations (CFR). part 136, Attachment B.

### **Minimum Level (ML)**

ML is the concentration at which the entire analytical system must give a recognizable signal and acceptable calibration point. The ML is the concentration in a sample that is equivalent to the concentration of the lowest calibration standard analyzed by a specific analytical procedure, assuming that all the method specified sample weights, volumes, and processing steps have been followed.

### **Mixing Zone**

Mixing Zone is a limited volume of receiving water that is allocated for mixing with a wastewater discharge where water quality criteria can be exceeded without causing adverse effects to the overall water body.

**Not Detected (ND)**

Sample results which are less than the laboratory's MDL.

**Off-line Settling Basins**

A constructed retention basin that receives wastewater from cleaning of aquaculture facility rearing/holding units, or quiescent zones, or both, for the retention and treatment of wastewater through settling of solids.

**Persistent Pollutants**

Persistent pollutants are substances for which degradation or decomposition in the environment is nonexistent or very slow.

**Pollutant Minimization Program (PMP)**

PMP means waste minimization and pollution prevention actions that include, but are not limited to, product substitution, waste stream recycling, alternative waste management methods, and education of the public and businesses. The goal of the PMP shall be to reduce all potential sources of a priority pollutant(s) through pollutant minimization (control) strategies, including pollution prevention measures as appropriate, to maintain the effluent concentration at or below the water quality-based effluent limitation. Pollution prevention measures may be particularly appropriate for persistent bioaccumulative priority pollutants where there is evidence that beneficial uses are being impacted. The Lahontan Water Board may consider cost effectiveness when establishing the requirements of a PMP. The completion and implementation of a Pollution Prevention Plan, if required pursuant to Water Code section 13263.3(d), must be considered to fulfill the PMP requirements.

**Pollution Prevention**

Pollution Prevention means any action that causes a net reduction in the use or generation of a hazardous substance or other pollutant that is discharged into water and includes, but is not limited to, input change, operational improvement, production process change, and product reformulation (as defined in Water Code section 13263.3). Pollution prevention does not include actions that merely shift a pollutant in wastewater from one environmental medium to another environmental medium, unless clear environmental benefits of such an approach are identified to the satisfaction of the State Water Resources Control Board (State Water Board) or Lahontan Water Board.

**Qualifying Rain Event**

Any event that produces 0.5 inches or more precipitation. A rain event is defined as separate from a second rain event if at least 48 hours separates the two.

**Reporting Level (RL)**

The RL is the ML (and its associated analytical method) chosen by the Discharger for reporting and compliance determination from the MLs included in this Order, including an additional factor if applicable as discussed herein. The MLs included in this Order correspond to approved analytical methods for reporting a sample result that are selected by the Lahontan Water Board either from Appendix 4 of the SIP in accordance

with section 2.4.2 of the SIP or established in accordance with section 2.4.3 of the SIP. The ML is based on the proper application of method-based analytical procedures for sample preparation and the absence of any matrix interferences. Other factors may be applied to the ML depending on the specific sample preparation steps employed. For example, the treatment typically applied in cases where there are matrix-effects is to dilute the sample or sample aliquot by a factor of ten. In such cases, this additional factor must be applied to the ML in the computation of the RL.

### **Source of Drinking Water**

Any water designated as municipal or domestic supply (MUN) in a Lahontan Water Board Basin Plan.

### **Standard Deviation ( $\sigma$ )**

Standard Deviation is a measure of variability that is calculated as follows:

$$\text{Standard Deviation } (\sigma) = \frac{\sum(X-\mu)^2}{(n-1)^{0.5}}$$

where: x is the observed value;  $\mu$  is the arithmetic mean of the observed values; and n is the number of samples.

### **Toxicity Reduction Evaluation (TRE)**

TRE is a study conducted in a step-wise process designed to identify the causative agents of effluent or ambient toxicity, isolate the sources of toxicity, evaluate the effectiveness of toxicity control options, and then confirm the reduction in toxicity. The first steps of the TRE consist of the collection of data relevant to the toxicity, including additional toxicity testing, and an evaluation of facility operations and maintenance practices, and best management practices. A Toxicity Identification Evaluation (TIE) may be required as part of the TRE, if appropriate. (A TIE is a set of procedures to identify the specific chemical(s) responsible for toxicity. These procedures are performed in three phases (characterization, identification, and confirmation) using aquatic organism toxicity tests.)

### **Treatment Period**

For flush treatments, the treatment period is the period beginning with the initial application of an aquaculture drug or chemical to a raceway or incubation building and ending when the aquaculture drug or chemical concentration is no longer present in the effluent following cessation of application in that raceway or incubation building or any subsequently treated raceways or incubation building. Where an aquaculture drug or chemical is applied for a period of more than one day in accordance with the label instructions and/or a veterinarian's prescription, the treatment period ends when the aquaculture drug or chemical concentration is no longer present in the effluent following cessation of application on the final day of the treatment.

**ATTACHMENT B – MAP**

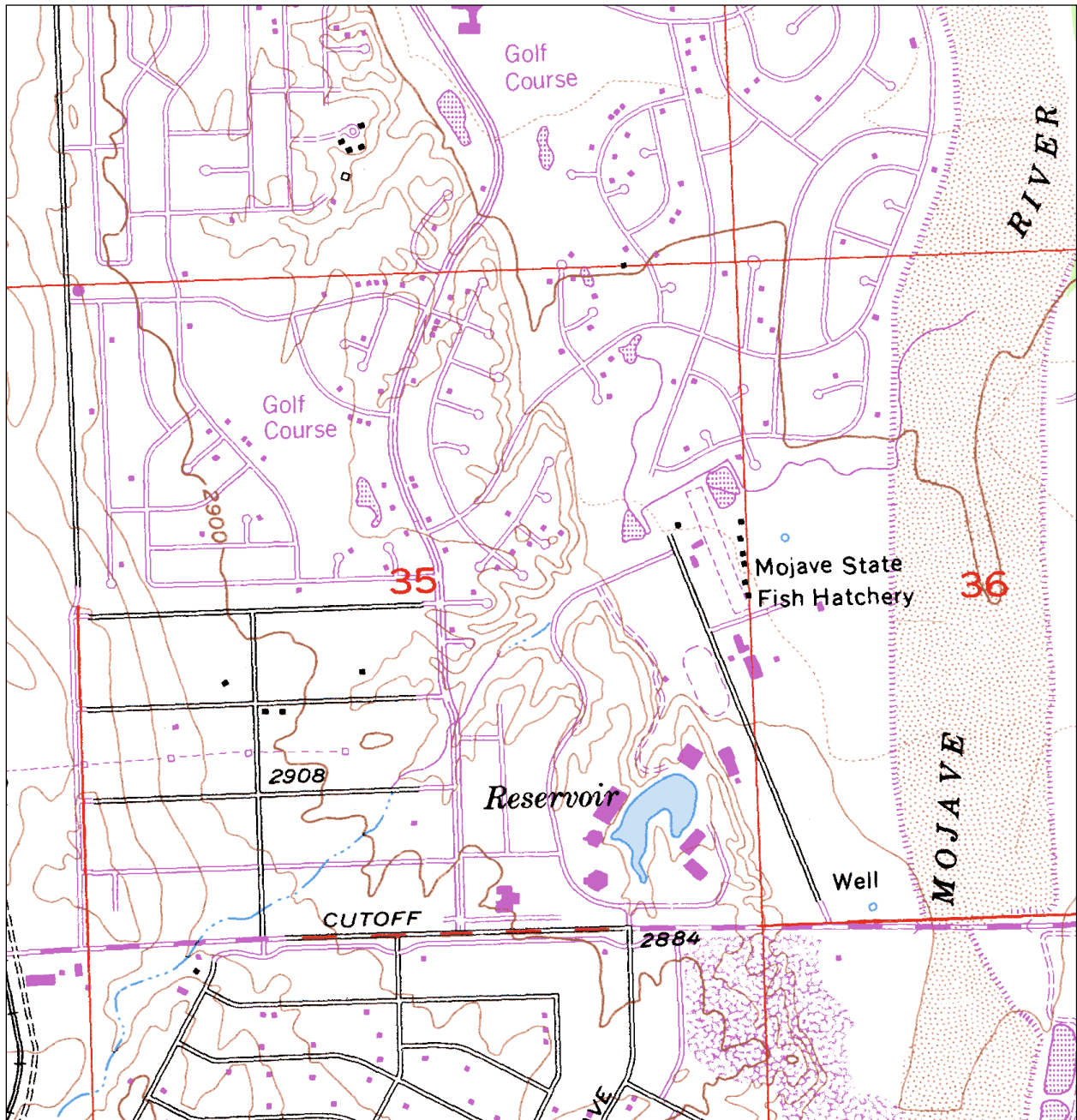

Mojave River Fish Hatchery  
12550 Jacaranda Avenue  
Victorville, CA 92395  
San Bernardino County

Latitude: 34° 28' 45" N  
Longitude: 117° 15' 38" W  
Section 36, T5N, R4W, SBB&M  
USGS Hesperia 7.5 Minute Quadrangle

**ATTACHMENT C – FLOW SCHEMATIC**

**Figure C-1. Flow Schematic**

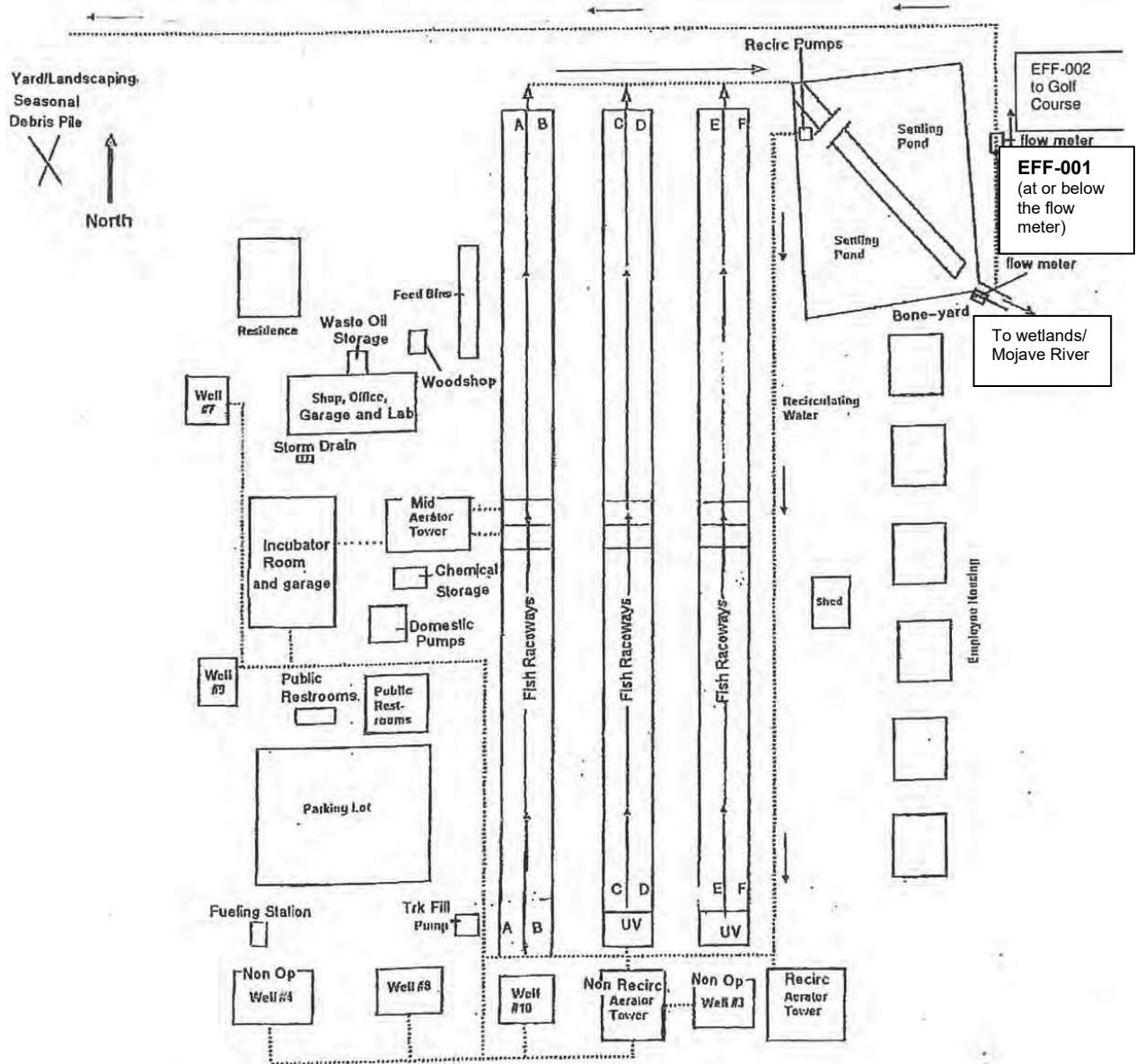
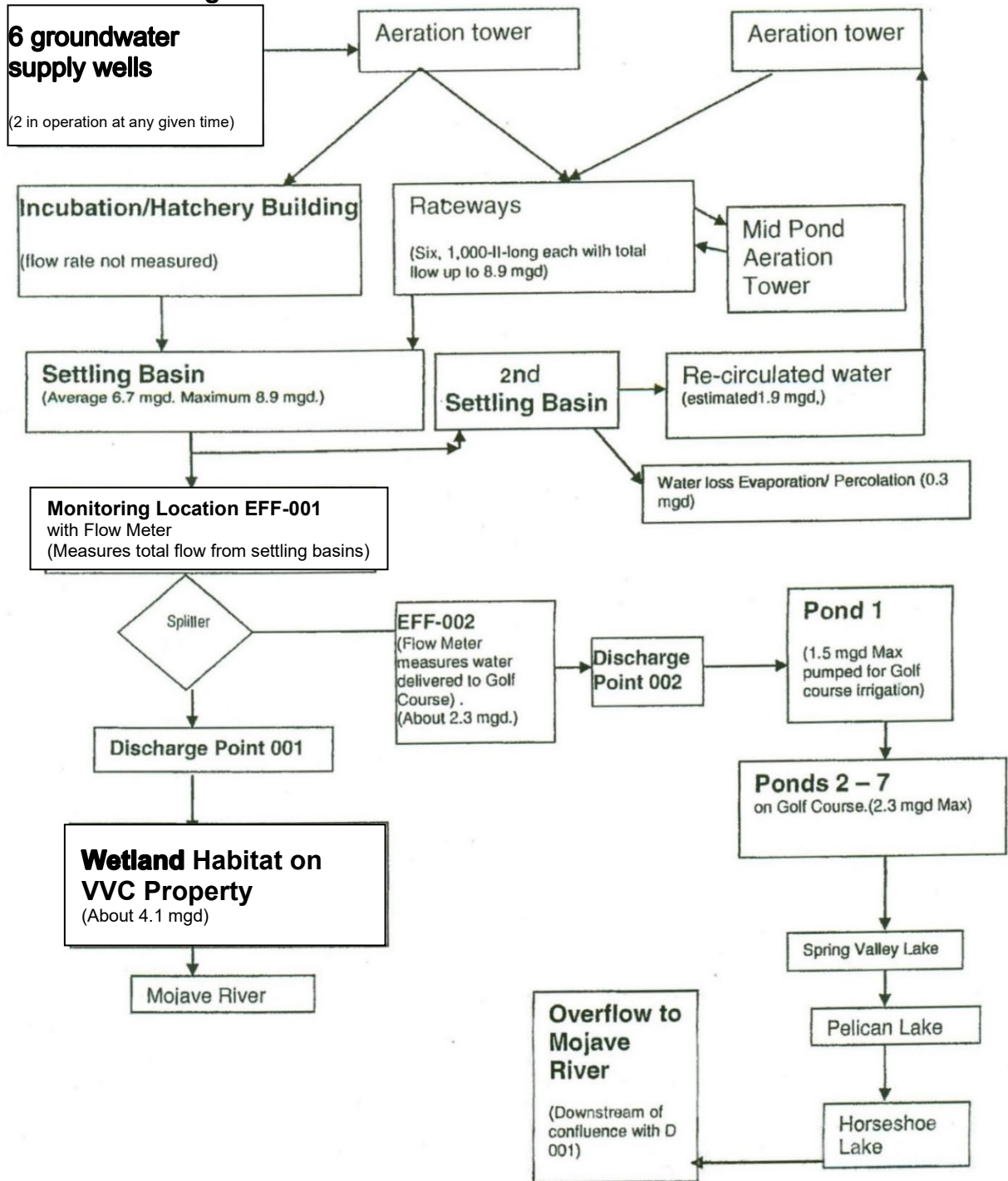
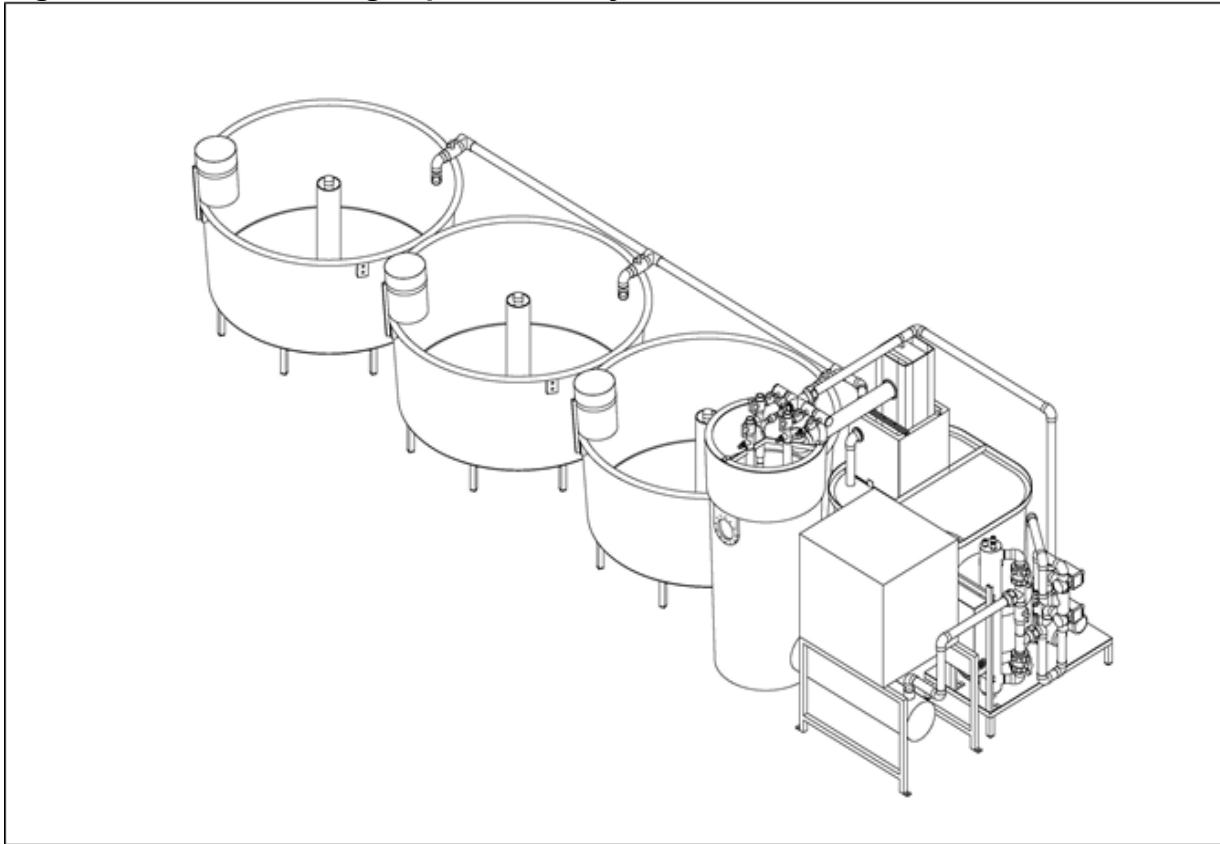



Figure C-2. Flow Diagram



**Figure C-3. Recirculating Aquaculture System Schematic**



## **ATTACHMENT D – STANDARD PROVISIONS**

### **1. STANDARD PROVISIONS – PERMIT COMPLIANCE**

#### **1.1. Duty to Comply**

- 1.1.1. The Discharger must comply with all of the terms, requirements, and conditions of this Order. Any noncompliance constitutes a violation of the Clean Water Act (CWA) and the California Water Code and is grounds for enforcement action; permit termination, revocation and reissuance, or modification; denial of a permit renewal application; or a combination thereof. (40 Code of Federal Regulations (C.F.R.) § 122.41(a); Wat. Code, §§ 13261, 13263, 13265, 13268, 13000, 13001, 13304, 13350, 13385.)
- 1.1.2. The Discharger must comply with effluent standards or prohibitions established under Section 307(a) of the CWA for toxic pollutants within the time provided in the regulations that establish these standards or prohibitions, even if this Order has not yet been modified to incorporate the requirement. (40 C.F.R. § 122.41(a)(1).)

#### **1.2. Need to Halt or Reduce Activity Not a Defense**

It must not be a defense for a Discharger in an enforcement action that it would have been necessary to halt or reduce the permitted activity in order to maintain compliance with the conditions of this Order. (40 C.F.R. § 122.41(c).)

#### **1.3. Duty to Mitigate**

The Discharger must take all reasonable steps to minimize or prevent any discharge in violation of this Order that has a reasonable likelihood of adversely affecting human health or the environment. (40 C.F.R. § 122.41(d).)

#### **1.4. Proper Operation and Maintenance**

The Discharger must at all times properly operate and maintain all facilities and systems of treatment and control (and related appurtenances) which are installed or used by the Discharger to achieve compliance with the conditions of this Order. Proper operation and maintenance also includes adequate laboratory controls and appropriate quality assurance procedures. This provision requires the operation of backup or auxiliary facilities or similar systems that are installed by a Discharger only when necessary to achieve compliance with the conditions of this Order. (40 C.F.R. § 122.41(e).)

#### **1.5. Property Rights**

- 1.5.1. This Order does not convey any property rights of any sort or any exclusive privileges. (40 C.F.R. § 122.41(g).)

1.5.2. The issuance of this Order does not authorize any injury to persons or property or invasion of other private rights, or any infringement of state or local law or regulations. (40 C.F.R. § 122.5(c).)

## 1.6. Inspection and Entry

The Discharger must allow the Lahontan Water Board, State Water Board, U.S. EPA, and/or their authorized representatives (including an authorized contractor acting as their representative), upon the presentation of credentials and other documents, as may be required by law, to (33 U.S.C. § 1318(a)(4)(B); 40 C.F.R. § 122.41(i); Wat. Code, §§ 13267, 13383):

- 1.6.1. Enter upon the Discharger's premises where a regulated facility or activity is located or conducted, or where records are kept under the conditions of this Order (33 U.S.C. § 1318(a)(4)(B)(i); 40 C.F.R. § 122.41(i)(1); Wat. Code, §§ 13267, 13383);
- 1.6.2. Have access to and copy, at reasonable times, any records that must be kept under the conditions of this Order (33 U.S.C. § 1318(a)(4)(B)(ii); 40 C.F.R. § 122.41(i)(2); Wat. Code, §§ 13267, 13383);
- 1.6.3. Inspect and photograph, at reasonable times, any facilities, equipment (including monitoring and control equipment), practices, or operations regulated or required under this Order (33 U.S.C. § 1318(a)(4)(B)(ii); 40 C.F.R. § 122.41(i)(3); Wat. Code, §§ 13267, 13383); and
- 1.6.4. Sample or monitor, at reasonable times, for the purposes of assuring Order compliance or as otherwise authorized by the CWA or the Water Code, any substances or parameters at any location. (33 U.S.C. § 1318(a)(4)(B); 40 C.F.R. § 122.41(i)(4); Wat. Code, §§ 13267, 13383.)

## 1.7. Bypass

### 1.7.1. Definitions

- 1.7.1.1. "Bypass" means the intentional diversion of waste streams from any portion of a treatment facility. (40 C.F.R. § 122.41(m)(1)(i).)
- 1.7.1.2. "Severe property damage" means substantial physical damage to property, damage to the treatment facilities, which causes them to become inoperable, or substantial and permanent loss of natural resources that can reasonably be expected to occur in the absence of a bypass. Severe property damage does not mean economic loss caused by delays in production. (40 C.F.R. § 122.41(m)(1)(ii).)

1.7.2. **Bypass not exceeding limitations.** The Discharger may allow any bypass to occur which does not cause exceedances of effluent limitations, but only if it is for essential maintenance to assure efficient operation. These bypasses are not subject to the provisions listed in Standard Provisions – Permit Compliance 1.7.3, 1.7.4, and 1.7.5 below. (40 C.F.R. § 122.41(m)(2).)

1.7.3. **Prohibition of bypass.** Bypass is prohibited, and the Lahontan Water Board may take enforcement action against a Discharger for bypass, unless (40 C.F.R. § 122.41(m)(4)(i)):

1.7.3.1. Bypass was unavoidable to prevent loss of life, personal injury, or severe property damage (40 C.F.R. § 122.41(m)(4)(i)(A));

1.7.3.2. There were no feasible alternatives to the bypass, such as the use of auxiliary treatment facilities, retention of untreated wastes, or maintenance during normal periods of equipment downtime. This condition is not satisfied if adequate back up equipment should have been installed in the exercise of reasonable engineering judgment to prevent a bypass that occurred during normal periods of equipment downtime or preventive maintenance (40 C.F.R. § 122.41(m)(4)(i)(B)); and

1.7.3.3. The Discharger submitted notice to the Lahontan Water Board as required under Standard Provisions – Permit Compliance 1.7.5 below. (40 C.F.R. § 122.41(m)(4)(i)(C).)

1.7.4. The Lahontan Water Board may approve an anticipated bypass, after considering its adverse effects, if the Lahontan Water Board determines that it will meet the three conditions listed in Standard Provisions – Permit Compliance 1.7.3 above. (40 C.F.R. § 122.41(m)(4)(ii).)

#### 1.7.5. **Notice**

1.7.5.1. **Anticipated bypass.** If the Discharger knows in advance of the need for a bypass, it must submit prior notice, if possible, at least 10 days before the date of the bypass. The notice must be sent to the Lahontan Water Board. As of December 21, 2023, all notices must be submitted electronically to the initial recipient defined in Standard Provisions – Reporting 5.10 below. Notices must comply with 40 C.F.R. part 3, 40 C.F.R. section 122.22, and 40 C.F.R. part 127. (40 C.F.R. § 122.41(m)(3)(i).)

1.7.5.2. **Unanticipated bypass.** The Discharger must submit a notice of an unanticipated bypass as required in Standard Provisions - Reporting V.E below (24-hour notice). The notice must be sent to the Lahontan Water Board. As of December 21, 2023, all notices must be submitted electronically to the initial recipient defined in Standard Provisions – Reporting 5.10 below. Notices must comply with 40 C.F.R. part 3, 40 C.F.R. section 122.22, and 40 C.F.R. part 127. (40 C.F.R. § 122.41(m)(3)(ii).)

#### 1.8. **Upset**

Upset means an exceptional incident in which there is unintentional and temporary noncompliance with technology-based permit effluent limitations because of factors beyond the reasonable control of the Discharger. An upset does not include noncompliance to the extent caused by operational error, improperly designed

treatment facilities, inadequate treatment facilities, lack of preventive maintenance, or careless or improper operation. (40 C.F.R. § 122.41(n)(1).)

- 1.8.1. **Effect of an upset.** An upset constitutes an affirmative defense to an action brought for noncompliance with such technology-based permit effluent limitations if the requirements of Standard Provisions – Permit Compliance 1.8.2 below are met. No determination made during administrative review of claims that noncompliance was caused by upset, and before an action for noncompliance, is final administrative action subject to judicial review. (40 C.F.R. § 122.41(n)(2).)
- 1.8.2 **Conditions necessary for a demonstration of upset.** A Discharger who wishes to establish the affirmative defense of upset must demonstrate, through properly signed, contemporaneous operating logs or other relevant evidence that (40 C.F.R. § 122.41(n)(3)):
  - 1.8.2.1. An upset occurred and that the Discharger can identify the cause(s) of the upset (40 C.F.R. § 122.41(n)(3)(i));
  - 1.8.2.2. The permitted facility was, at the time, being properly operated (40 C.F.R. § 122.41(n)(3)(ii));
  - 1.8.2.3. The Discharger submitted notice of the upset as required in Standard Provisions – Reporting 5.5.2.2 below (24-hour notice) (40 C.F.R. § 122.41(n)(3)(iii)); and
  - 1.8.2.4. The Discharger complied with any remedial measures required under Standard Provisions – Permit Compliance 1.3 above. (40 C.F.R. § 122.41(n)(3)(iv).)
- 1.8.3. **Burden of proof.** In any enforcement proceeding, the Discharger seeking to establish the occurrence of an upset has the burden of proof. (40 C.F.R. § 122.41(n)(4).)

## 2. STANDARD PROVISIONS – PERMIT ACTION

### 2.1. General

This Order may be modified, revoked and reissued, or terminated for cause. The filing of a request by the Discharger for modification, revocation and reissuance, or termination, or a notification of planned changes or anticipated noncompliance does not stay any Order condition. (40 C.F.R. § 122.41(f).)

### 2.2. Duty to Reapply

If the Discharger wishes to continue an activity regulated by this Order after the expiration date of this Order, the Discharger must apply for and obtain a new permit. (40 C.F.R. § 122.41(b).)

### 2.3. Transfers

This Order is not transferable to any person except after notice to the Lahontan Water Board. The Lahontan Water Board may require modification or revocation

and reissuance of the Order to change the name of the Discharger and incorporate such other requirements as may be necessary under the CWA and the Water Code. (40 C.F.R. §§ 122.41(l)(3), 122.61.)

### **3. STANDARD PROVISIONS – MONITORING**

- 3.1. Samples and measurements taken for the purpose of monitoring must be representative of the monitored activity. (40 C.F.R. § 122.41(j)(1).)
- 3.2. Monitoring must be conducted according to test procedures approved under 40 C.F.R. part 136 for the analyses of pollutants unless another method is required under 40 C.F.R. chapter 1, subchapter N. Monitoring must be conducted according to sufficiently sensitive test methods approved under 40 C.F.R. part 136 for the analysis of pollutants or pollutant parameters or as required under 40 C.F.R. chapter 1, subchapter N. For the purposes of this paragraph, a method is sufficiently sensitive when:
  - 3.2.1. The method minimum level (ML) is at or below the level of the most stringent effluent limitation established in the permit for the measured pollutant or pollutant parameter, and either the method ML is at or below the level of the most stringent applicable water quality criterion for the measured pollutant or pollutant parameter or the method ML is above the applicable water quality criterion but the amount of the pollutant or pollutant parameter in the facility's discharge is high enough that the method detects and quantifies the level of the pollutant or pollutant parameter in the discharge; or
  - 3.2.2. The method has the lowest ML of the analytical methods approved under 40 C.F.R. part 136 or required under 40 C.F.R. chapter 1, subchapter N for the measured pollutant or pollutant parameter. In the case of pollutants or pollutant parameters for which there are no approved methods under 40 C.F.R. part 136, or otherwise required under 40 C.F.R. chapter 1, subchapter N, monitoring must be conducted according to a test procedure specified in this Order for such pollutants or pollutant parameters. (40 C.F.R. §§ 122.21(e)(3), 122.41(j)(4), 122.44(i)(1)(iv).)

#### **4. STANDARD PROVISIONS – RECORDS**

**4.1.** The Discharger must retain records of all monitoring information, including all calibration and maintenance records and all original strip chart recordings for continuous monitoring instrumentation, copies of all reports required by this Order, and records of all data used to complete the application for this Order, for a period of at least three (3) years from the date of the sample, measurement, report or application. This period may be extended by request of the Lahontan Water Board Executive Officer at any time. (40 C.F.R. § 122.41(j)(2).)

#### **4.2. Records of monitoring information must include:**

4.2.1. The date, exact place, and time of sampling or measurements (40 C.F.R. § 122.41(j)(3)(i));

4.2.2. The individual(s) who performed the sampling or measurements (40 C.F.R. § 122.41(j)(3)(ii));

4.2.3. The date(s) analyses were performed (40 C.F.R. § 122.41(j)(3)(iii));

4.2.4. The individual(s) who performed the analyses (40 C.F.R. § 122.41(j)(3)(iv));

4.2.5. The analytical techniques or methods used (40 C.F.R. § 122.41(j)(3)(v)); and

4.2.6. The results of such analyses. (40 C.F.R. § 122.41(j)(3)(vi).)

#### **4.3. Claims of confidentiality for the following information will be denied (40 C.F.R. § 122.7(b)):**

4.3.1. The name and address of any permit applicant or Discharger (40 C.F.R. § 122.7(b)(1)); and

4.3.2. Permit applications and attachments, permits and effluent data. (40 C.F.R. § 122.7(b)(2).)

#### **5. STANDARD PROVISIONS – REPORTING**

##### **5.1. Duty to Provide Information**

The Discharger must furnish to the Lahontan Water Board, State Water Board, or U.S. EPA within a reasonable time, any information which the Lahontan Water Board, State Water Board, or U.S. EPA may request to determine whether cause exists for modifying, revoking and reissuing, or terminating this Order or to determine compliance with this Order. Upon request, the Discharger must also furnish to the Lahontan Water Board, State Water Board, or U.S. EPA copies of records required to be kept by this Order. (40 C.F.R. § 122.41(h); Wat. Code, §§ 13267, 13383.)



## 5.2. Signatory and Certification Requirements

- 5.2.1. All applications, reports, or information submitted to the Lahontan Water Board, State Water Board, and/or U.S. EPA must be signed and certified in accordance with Standard Provisions – Reporting 5.2.2, 5.2.3, 5.2.4, 5.2.5, and 5.2.6 below. (40 C.F.R. § 122.41(k).)
- 5.2.2. All permit applications must be signed by either a principal executive officer or ranking elected official. For purposes of this provision, a principal executive officer of a federal agency includes: (i) the chief executive officer of the agency, or (ii) a senior executive officer having responsibility for the overall operations of a principal geographic unit of the agency (e.g., Regional Administrators of U.S. EPA). (40 C.F.R. § 122.22(a)(3).)
- 5.2.3. All reports required by this Order and other information requested by the Lahontan Water Board, State Water Board, or U.S. EPA must be signed by a person described in Standard Provisions – Reporting 5.2.2 above, or by a duly authorized representative of that person. A person is a duly authorized representative only if:
- 5.2.3.1. The authorization is made in writing by a person described in Standard Provisions – Reporting 5.2.2 above (40 C.F.R. § 122.22(b)(1));
- 5.2.3.2. The authorization specifies either an individual or a position having responsibility for the overall operation of the regulated facility or activity such as the position of plant manager, operator of a well or a well field, superintendent, position of equivalent responsibility, or an individual or position having overall responsibility for environmental matters for the company. (A duly authorized representative may thus be either a named individual or any individual occupying a named position.) (40 C.F.R. § 122.22(b)(2)); and
- 5.2.3.3. The written authorization is submitted to the Lahontan Water Board and State Water Board. (40 C.F.R. § 122.22(b)(3).)
- 5.2.4. If an authorization under Standard Provisions – Reporting 5.2.3 above is no longer accurate because a different individual or position has responsibility for the overall operation of the facility, a new authorization satisfying the requirements of Standard Provisions – Reporting 5.2.3 above must be submitted to the Lahontan Water Board and State Water Board prior to or together with any reports, information, or applications, to be signed by an authorized representative. (40 C.F.R. § 122.22(c).)
- 5.2.5. Any person signing a document under Standard Provisions – Reporting 5.2.2 or 5.2.3 above must make the following certification:
- “I certify under penalty of law that this document and all attachments were prepared under my direction or supervision in accordance with a system designed to assure that qualified personnel properly gather and evaluate the information submitted. Based on my inquiry of the person or persons who manage the system or those persons directly responsible for gathering the information, the

information submitted is, to the best of my knowledge and belief, true, accurate, and complete. I am aware that there are significant penalties for submitting false information, including the possibility of fine and imprisonment for knowing violations.” (40 C.F.R. § 122.22(d).)

- 5.2.6. Any person providing the electronic signature for documents described in Standard Provisions – 5.2.1, 5.2.2, or 5.2.3 that are submitted electronically must meet all relevant requirements of Standard Provisions – Reporting 5.2, and must ensure that all relevant requirements of 40 C.F.R. part 3 (Cross-Media Electronic Reporting) and 40 C.F.R. part 127 (NPDES Electronic Reporting Requirements) are met for that submission. (40 C.F.R § 122.22(e).)

### **5.3. Monitoring Reports**

- 5.3.1. Monitoring results must be reported at the intervals specified in the Monitoring and Reporting Program (Attachment E) in this Order. (40 C.F.R. § 122.41(l)(4).)
- 5.3.2. Monitoring results must be reported on a Discharge Monitoring Report (DMR) form or forms provided or specified by the Lahontan Water Board or State Water Board. As of December 21, 2016, all reports and forms must be submitted electronically to the initial recipient defined in Standard Provisions – Reporting 5.10 and comply with 40 C.F.R. part 3, 40 C.F.R. section 122.22, and 40 C.F.R. part 127. (40 C.F.R. § 122.41(l)(4)(i).)
- 5.3.3. If the Discharger monitors any pollutant more frequently than required by this Order using test procedures approved under 40 C.F.R. part 136, or another method required for an industry-specific waste stream under 40 C.F.R. chapter 1, subchapter N, the results of such monitoring must be included in the calculation and reporting of the data submitted in the DMR or reporting form specified by the Lahontan Water Board or State Water Board. (40 C.F.R. § 122.41(l)(4)(ii).)
- 5.3.4. Calculations for all limitations, which require averaging of measurements, must utilize an arithmetic mean unless otherwise specified in this Order. (40 C.F.R. § 122.41(l)(4)(iii).)

### **5.4. Compliance Schedules**

Reports of compliance or noncompliance with, or any progress reports on, interim and final requirements contained in any compliance schedule of this Order, must be submitted no later than 14 days following each schedule date. (40 C.F.R. § 122.41(l)(5).)

### **5.5. Twenty-Four Hour Reporting**

- 5.5.1. The Discharger must report any noncompliance which may endanger health or the environment. Any information must be provided orally within 24 hours from the time the Discharger becomes aware of the circumstances. A report must also be provided within five (5) days of the time the Discharger becomes aware of the

circumstances. The report must contain a description of the noncompliance and its cause; the period of noncompliance, including exact dates and times, and if the noncompliance has not been corrected, the anticipated time it is expected to continue; and steps taken or planned to reduce, eliminate, and prevent reoccurrence of the noncompliance.

For noncompliance events related to combined sewer overflows, sanitary sewer overflows, or bypass events, these reports must include the data described above (with the exception of time of discovery) as well as the type of event (i.e., combined sewer overflow, sanitary sewer overflow, or bypass event), type of overflow structure (e.g., manhole, combined sewer overflow outfall), discharge volume untreated by the treatment works treating domestic sewage, types of human health and environmental impacts of the event, and whether the noncompliance was related to wet weather.

As of December 21, 2023, all reports related to combined sewer overflows, sanitary sewer overflows, or bypass events must be submitted to the Lahontan Water Board and must be submitted electronically to the initial recipient defined in Standard Provisions – Reporting 5.10 The reports must comply with 40 C.F.R. part 3, 40 C.F.R. section 122.22, and 40 C.F.R. part 127. The Lahontan Water Board may also require the Discharger to electronically submit reports not related to combined sewer overflows, sanitary sewer overflows, or bypass events under this section. (40 C.F.R. § 122.41(l)(6)(i))

5.5.2. The following must be included as information that must be reported within 24 hours:

5.5.2.1. Any unanticipated bypass that exceeds any effluent limitation in this Order. (40 C.F.R. § 122.41(l)(6)(ii)(A).)

5.5.2.2. Any upset that exceeds any effluent limitation in this Order. (40 C.F.R. § 122.41(l)(6)(ii)(B).)

5.5.3. The Lahontan Water Board may waive the above required written report on a case-by-case basis if an oral report has been received within 24 hours. (40 C.F.R. § 122.41(l)(6)(ii)(B).)

## **5.6. Planned Changes**

The Discharger must give notice to the Lahontan Water Board as soon as possible of any planned physical alterations or additions to the permitted facility. Notice is required under this provision only when (40 C.F.R. § 122.41(l)(1)):

5.6.1. The alteration or addition to a permitted facility may meet one of the criteria for determining whether a facility is a new source in section 122.29(b) (40 C.F.R. § 122.41(l)(1)(i)); or

5.6.2. The alteration or addition could significantly change the nature or increase the quantity of pollutants discharged. This notification applies to pollutants that are subject neither to effluent limitations in this Order nor to notification requirements

under section 122.42(a)(1) (see Additional Provisions—Notification Levels 7.1.1).  
(40 C.F.R. § 122.41(l)(1)(ii).)

### **5.7. Anticipated Noncompliance**

The Discharger must give advance notice to the Lahontan Water Board of any planned changes in the permitted facility or activity that may result in noncompliance with this Order's requirements. (40 C.F.R. § 122.41(l)(2).)

### **5.8. Other Noncompliance**

The Discharger must report all instances of noncompliance not reported under Standard Provisions – Reporting 5.3, 5.4, and 5.5 above at the time monitoring reports are submitted. The reports must contain the information listed in Standard Provision – Reporting 5.5 above. For noncompliance events related to combined sewer overflows, sanitary sewer overflows, or bypass events, these reports must contain the information described in Standard Provision – Reporting 5.5 and the applicable required data in appendix A to 40 C.F.R. part 127. The Lahontan Water Board may also require the Discharger to electronically submit reports not related to combined sewer overflows, sanitary sewer overflows, or bypass events under this section. (40 C.F.R. § 122.41(l)(7).)

### **5.9 Other Information**

When the Discharger becomes aware that it failed to submit any relevant facts in a permit application, or submitted incorrect information in a permit application or in any report to the Lahontan Water Board, State Water Board, or U.S. EPA, the Discharger must promptly submit such facts or information.  
(40 C.F.R. § 122.41(l)(8).)

### **5.10. Initial Recipient for Electronic Reporting Data**

The owner, operator, or the duly authorized representative is required to electronically submit NPDES information specified in appendix A to 40 C.F.R. part 127 to the initial recipient defined in 40 C.F.R. section 127.2(b). U.S. EPA will identify and publish the list of initial recipients on its website and in the Federal Register, by state and by NPDES data group [see 40 C.F.R. section 127.2(c)]. U.S. EPA will update and maintain this listing. (40 C.F.R. § 122.41(l)(9).)

## **6. STANDARD PROVISIONS – ENFORCEMENT**

6.1. The Lahontan Water Board is authorized to enforce the terms of this permit under several provisions of the Water Code, including, but not limited to, sections 13268, 13385, 13386, and 13387.

## 7. ADDITIONAL PROVISIONS – NOTIFICATION LEVELS

### 7.1. Non-Municipal Facilities

Existing manufacturing, commercial, mining, and silvicultural Dischargers must notify the Lahontan Water Board as soon as they know or have reason to believe (40 C.F.R. § 122.42(a)):

- 7.1.1. That any activity has occurred or will occur that would result in the discharge, on a routine or frequent basis, of any toxic pollutant that is not limited in this Order, if that discharge will exceed the highest of the following "notification levels" (40 C.F.R. § 122.42(a)(1)):
  - 7.1.1.1. 100 micrograms per liter ( $\mu\text{g/L}$ ) (40 C.F.R. § 122.42(a)(1)(i));
  - 7.1.1.2. 200  $\mu\text{g/L}$  for acrolein and acrylonitrile; 500  $\mu\text{g/L}$  for 2,4 dinitrophenol and 2-methyl 4,6 dinitrophenol; and 1 milligram per liter ( $\text{mg/L}$ ) for antimony (40 C.F.R. § 122.42(a)(1)(ii));
  - 7.1.1.3. Five (5) times the maximum concentration value reported for that pollutant in the Report of Waste Discharge (40 C.F.R. § 122.42(a)(1)(iii)); or
  - 7.1.1.4. The level established by the Lahontan Water Board in accordance with section 122.44(f). (40 C.F.R. § 122.42(a)(1)(iv).)
- 7.1.2. That any activity has occurred or will occur that would result in the discharge, on a non-routine or infrequent basis, of any toxic pollutant that is not limited in this Order, if that discharge will exceed the highest of the following "notification levels" (40 C.F.R. § 122.42(a)(2)):
  - 7.1.2.1. 500 micrograms per liter ( $\mu\text{g/L}$ ) (40 C.F.R. § 122.42(a)(2)(i));
  - 7.1.2.2. 1 milligram per liter ( $\text{mg/L}$ ) for antimony (40 C.F.R. § 122.42(a)(2)(ii));
  - 7.1.2.3. Ten (10) times the maximum concentration value reported for that pollutant in the Report of Waste Discharge (40 C.F.R. § 122.42(a)(2)(iii)); or
  - 7.1.2.4. The level established by the Lahontan Water Board in accordance with section 122.44(f). (40 C.F.R. § 122.42(a)(2)(iv).)

**ATTACHMENT E – MONITORING AND REPORTING PROGRAM**

**TABLE OF CONTENTS**

1. GENERAL MONITORING PROVISIONS.....	E-2
2. MONITORING LOCATIONS .....	E-4
3. INFLUENT MONITORING REQUIREMENTS.....	E-5
3.1. Monitoring Location INF-001.....	E-5
4. EFFLUENT MONITORING REQUIREMENTS.....	E-6
4.1. Monitoring Location EFF-001.....	E-6
4.2. Monitoring Location EFF-002.....	E-9
4.3. Monitoring Location EFF-003.....	E-10
5. WHOLE EFFLUENT TOXICITY TESTING REQUIREMENTS – NOT APPLICABLE.....	E-10
6. LAND DISCHARGE MONITORING REQUIREMENTS – NOT APPLICABLE .....	E-10
7. RECYCLING MONITORING REQUIREMENTS – NOT APPLICABLE .....	E-10
8. RECEIVING WATER MONITORING REQUIREMENTS – NOT APPLICABLE .....	E-10
9. OTHER MONITORING REQUIREMENTS.....	E-10
10. REPORTING REQUIREMENTS .....	E-14
10.1. General Monitoring and Reporting Requirements.....	E-14
10.3. Discharge Monitoring Reports (DMRs) .....	E-17
10.4. Other Reports .....	E-17
10.5. Summary of Reports .....	E-18

**TABLE OF TABLES**

Table E-1. Monitoring Station Locations.....	E-4
Table E-2. Influent Monitoring (INF-001).....	E-6
Table E-3. Effluent Monitoring (EFF-001).....	E-7
Table E-4. Effluent Monitoring (EFF-002).....	E-10
Table E-5. Effluent Monitoring (EFF-003).....	E-10
Table E-6. Monitoring Periods and Reporting Schedule.....	E-15
Table E-8. Summary of Reports.....	E-18

## ATTACHMENT E – MONITORING AND REPORTING PROGRAM

Section 308 of the federal Clean Water Act (CWA) and sections 122.41(h), (j)-(l), 122.44(i), and 122.48 of title 40 of the Code of Federal Regulations (40 C.F.R.) require that all NPDES permits specify monitoring and reporting requirements. Water Code sections 13267 and 13383 also authorize the Lahontan Water Board to establish monitoring, inspection, entry, reporting, and recordkeeping requirements. This Monitoring and Reporting Program MRP establishes monitoring, reporting, and recordkeeping requirements that implement the federal and California laws and/or regulations.

### 1. GENERAL MONITORING PROVISIONS

- 1.1. Samples and measurements taken as required herein must be representative of the volume and nature of the monitored discharge. All samples must be taken at the monitoring locations specified below and, unless otherwise specified, before the monitored flow joins or is diluted by any other waste stream, body of water, or substance. Monitoring locations must not be changed without notification to and the approval from the Lahontan Water Board.
- 1.2. Effluent samples must be taken downstream of the last addition of wastes to the treatment or discharge works where a representative sample may be obtained prior to mixing with the receiving waters. Samples must be collected at such a point and in such a manner to ensure a representative sample of the discharge.
- 1.3. Appropriate flow measurement devices and methods consistent with accepted scientific practices must be selected and used to ensure accuracy and reliability for measuring discharge volumes. The flow measurement devices must be installed, calibrated, and maintained to ensure that the accuracy of the measurements is consistent with the accepted capability of that type of device. Devices selected must be capable of measuring flows with a maximum deviation of less than  $\pm 10$  percent from true discharge rates throughout the range of expected discharge volumes.
- 1.4. **Laboratory Certification:** Laboratories analyzing monitoring samples must be certified by the State Water Resources Control Board (State Water Board), in accordance with the provision of Water Code section 13176, and must include quality assurance/quality control data with their reports. In the event a certified laboratory is not available to the Discharger, analyses performed by a non-certified laboratory or using field test kits will be accepted provided that a QA/QC Program is instituted by the laboratory and approved by the Executive Officer. Documentation of QA/QC protocols and adherence to the protocols must be kept in the laboratory or at the site for field test kits and must be available for inspection by Lahontan Water Board staff. The QA/QC Program must conform to U.S. Environmental Protection Agency (U.S. EPA) guidelines or to procedures approved by the Lahontan Water Board. Supplemental field testing for constituents that could be analyzed by a certified laboratory may be done in the field with test kits and meters provided:

- 1.4.1. Samples collected at the minimum-required monitoring frequencies are performed by a certified lab,
- 1.4.2. A QA/QC Program approved by the Executive Officer or Designee is followed,
- 1.4.3. Detection limits, accuracy, and precision of the kits and meters meet U.S. EPA and Surface Water Ambient Monitoring Program (SWAMP) standards, and
- 1.4.4. All results for field testing must be reported to the Lahontan Water Board in quarterly and annual self-monitoring reports (SMRs). Supporting QA/QC data must be determined using an established program and retained onsite and reported if requested.
- 1.5. All monitoring instruments and devices used by the Discharger to fulfill the prescribed monitoring program must be properly maintained and calibrated as necessary to ensure their continued accuracy. All flow measurement devices must be calibrated at least once per year to ensure continued accuracy of the devices.
- 1.6. Monitoring results, including noncompliance, must be reported at intervals and in a manner specified in this MRP.
- 1.7. The results of all monitoring required by this Order must be reported to the Lahontan Water Board and must be submitted in such a format as to allow direct comparison with the limitations and requirements of this Order. Unless otherwise specified, discharge flows must be reported in terms of the monthly average and the daily maximum discharge flows.
- 1.8. The Discharger must ensure that the results of the Discharge Monitoring Report-Quality Assurance (DMR-QA) Study or the most recent Water Pollution Performance Evaluation Study are submitted annually to the State Water Board at the following address:  
  
State Water Resources Control Board;  
Quality Assurance Program Officer;  
Office of Information Management and Analysis;  
1001 I Street, Sacramento, CA 95814
- 1.9. Minimum Level (ML) and Analytical Method Selection: U.S. EPA published regulations for the Sufficiently Sensitive Methods Rule (SSM Rule) which became effective September 18, 2015. For the purposes of the NPDES program, when more than one test procedure is approved under 40 C.F.R. part 136 for the analysis of a pollutant or pollutant parameter, the test procedure must be sufficiently sensitive as defined at 40 C.F.R. 122.21(e)(3) and 122.44(i)(1)(iv). Both 40 C.F.R. sections 122.21(e)(3) and 122.44(i)(1)(iv) apply to the selection of a sufficiently sensitive analytical method for the purposes of monitoring and reporting under NPDES permits, including review of permit applications. A U.S. EPA-approved analytical method is sufficiently sensitive where:
  - 1.9.1. The ML is at or below both the level of the applicable water quality criterion/objective and the permit limitation for the measured pollutant or pollutant parameter; or



- 1.9.2. In permit applications, the ML is above the applicable water quality criterion/objective, but the amount of the pollutant or pollutant parameter in a facility's discharge is high enough that the method detects and quantifies the level of the pollutant or pollutant parameter in the discharge; or
- 1.9.3. The method has the lowest ML of the U.S. EPA-approved analytical methods where none of the U.S. EPA-approved analytical methods for a pollutant can achieve the MLs necessary to assess the need for effluent limitations or to monitor compliance with a permit limitation.

**2. MONITORING LOCATIONS**

The Discharger must establish the following monitoring locations to demonstrate compliance with the effluent limitations, discharge specifications, and other requirements in this Order:

**Table E-1. Monitoring Station Locations**

<b>Discharge Point Name</b>	<b>Monitoring Location Name</b>	<b>Monitoring Location Description</b>
-	INF-001	At the head box of the production raceways, where a representative sample of influent water from the groundwater supply wells can be obtained prior to entering the fish rearing ponds or mixing with recirculation water. Latitude: 34.477993 Longitude: -117.260301
001 and 002	EFF-001	From the final splitter box at the outfall from the settling pond. Latitude: 34.480556 Longitude: -117.26
002	EFF-002	In the surface water channel to the Spring Valley Lake Homeowners Association property, after the splitter box and before the channel terminates at Pond 1. Latitude: 34.479722 Longitude: -117.2625
001	EFF-003	Effluent flow to the Mojave River and adjacent wetlands from Discharge Point 001 (calculated).

Monitoring for total combined flow at EFF-001 must be measured at the outfall from the settling pond after the split to the second settling basin and prior to the final splitter box and sluice gate.

The North latitude and West longitude information in Table E-1 are approximate for administrative purposes.

### 3. INFLUENT MONITORING REQUIREMENTS

#### 3.1. Monitoring Location INF-001

- 3.1.1. The Discharger shall monitor the influent to the Facility at Monitoring Location INF-001 as described in Table E-2.
- 3.1.2. All chemicals and parameters including pollutants shall be analyzed using the analytical methods described in 40 C.F.R. part 136. Where no methods are specified for a given pollutant, pollutants shall be analyzed in accordance with the current edition of Standard Methods for Examination of Water and Wastewater (American Public Health Administration) or by a method proposed by the Discharger and approved by the Executive Officer. Field tests are authorized for Electrical Conductivity, pH, Dissolved Oxygen (DO), Temperature, and Turbidity because it is impractical to analyze these parameters in an ELAP certified lab. Standard quality control must be exercised regarding equipment calibration etc..
- 3.1.3. All pH and Electrical Conductivity measurements, taken as field tests, must be conducted concurrently with the respective collection of influent and effluent samples
- 3.1.4. Analytical methods must achieve the lowest minimum level (ML) specified in Attachment 4 of the SIP; and in accordance with Section 2.4 of the SIP, the Permittee shall report the ML and MDL for each sample result.
  - 3.1.4.1. **Minimum Level (ML) and Analytical Method Selection:** U.S. EPA published regulations for the Sufficiently Sensitive Methods Rule (SSM Rule) which became effective September 18, 2015. For the purposes of the NPDES program, when more than one test procedure is approved under 40 C.F.R. part 136 for the analysis of a pollutant or pollutant parameter, the test procedure must be sufficiently sensitive as defined at 40 C.F.R. 122.21(e)(3) and 122.44(i)(1)(iv). Both 40 C.F.R sections 122.21(e)(3) and 122.44(i)(1)(iv) apply to the selection of a sufficiently sensitive analytical method for the purposes of monitoring and reporting under NPDES permits, including review of permit applications. A U.S. EPA-approved analytical method is sufficiently sensitive where:
    - A. The ML is at or below both the level of the applicable water quality criterion/objective and the permit limitation for the measured pollutant or pollutant parameter; or
    - B. In permit applications, the ML is above the applicable water quality criterion/objective, but the amount of the pollutant or pollutant parameter in a facility's discharge is high enough that the method detects and quantifies the level of the pollutant or pollutant parameter in the discharge; or
    - C. The method has the lowest ML of the U.S. EPA-approved analytical methods where none of the U.S. EPA-approved analytical methods for a pollutant can achieve the MLs necessary to assess the need for effluent limitations or to monitor compliance with a permit limitation.

**Table E-2. Influent Monitoring (INF-001)**

<b>Parameter</b>	<b>Units</b>	<b>Sample Type</b>	<b>Minimum Sampling Frequency</b>
Boron, Total Recoverable	mg/L	Grab	1/Permit Term
Chloride	mg/L	Grab	1/Permit Term
Electrical Conductivity @ 25°C	µmhos/cm	Grab	1/Month
Fluoride, Total	mg/L	Grab	1/Year
Nitrate Nitrogen, Total (as N)	mg/L	Grab	1/Year
Nitrogen, Total (as N)	mg/L	Grab	1/Year
pH	standard units	Grab	1/Month
Sulfate, Total (as SO <sub>4</sub> )	mg/L	Grab	1/Permit Term
Temperature	°C	Grab	1/Month
Total Dissolved Solids (TDS)	mg/L	Grab	1/Permit Term

**4. EFFLUENT MONITORING REQUIREMENTS**

**4.1. Monitoring Location EFF-001**

- 4.1.1. The Discharger shall monitor effluent from the Facility at Monitoring Location EFF-001 as described in Table E-3.
- 4.1.2. For all parameters, a sample of the effluent shall be collected at a time when the concentration of the parameter in the effluent is expected to be at a maximum. All pH and Electrical Conductivity measurements, taken as field tests, must be conducted concurrently with the respective collection of influent and effluent samples
- 4.1.3. All chemicals and parameters, including pollutants shall be analyzed using the analytical methods described in 40 C.F.R. part 136. Where no methods are specified for a given pollutant, pollutants shall be analyzed in accordance with the current edition of Standard Methods for Examination of Water and Wastewater (American Public Health Administration) or by a method proposed by the Discharger and approved by the Executive Officer. Field tests are authorized for Electrical Conductivity, pH, Dissolved Oxygen (DO), Temperature, and Turbidity because it is impractical to analyze these parameters in an ELAP certified lab. Standard quality control must be exercised regarding equipment calibration etc.
- 4.1.4. When a chemical is added to the waters of the Facility, a sample of the effluent must be collected after the application of the chemical. After the initial sample, if subsequent treatments within a given quarter use the same amount of chemical and flow rate at the time of application, and the applied concentration is

calculated to be the same as the initial sample the Discharger must either submit a calculated final effluent concentration each reporting period or monitoring results from a new collected sample.

4.1.5. Analytical methods must achieve the lowest minimum level (ML) specified in Attachment 4 of the SIP; and in accordance with Section 2.4 of the SIP, the Permittee shall report the ML and MDL for each sample result.

4.1.5.1. Minimum Level (ML) and Analytical Method Selection: U.S. EPA published regulations for the Sufficiently Sensitive Methods Rule (SSM Rule) which became effective September 18, 2015. For the purposes of the NPDES program, when more than one test procedure is approved under 40 C.F.R. part 136 for the analysis of a pollutant or pollutant parameter, the test procedure must be sufficiently sensitive as defined at 40 C.F.R. 122.21(e)(3) and 122.44(i)(1)(iv). Both 40 C.F.R sections 122.21(e)(3) and 122.44(i)(1)(iv) apply to the selection of a sufficiently sensitive analytical method for the purposes of monitoring and reporting under NPDES permits, including review of permit applications. A U.S. EPA-approved analytical method is sufficiently sensitive where:

- A. The ML is at or below both the level of the applicable water quality criterion/objective and the permit limitation for the measured pollutant or pollutant parameter; or
- B. In permit applications, the ML is above the applicable water quality criterion/objective, but the amount of the pollutant or pollutant parameter in a facility's discharge is high enough that the method detects and quantifies the level of the pollutant or pollutant parameter in the discharge; or
- C. The method has the lowest ML of the U.S. EPA-approved analytical methods where none of the U.S. EPA-approved analytical methods for a pollutant can achieve the MLs necessary to assess the need for effluent limitations or to monitor compliance with a permit limitation.

**Table E-3. Effluent Monitoring (EFF-001)**

<b>Parameter</b>	<b>Units</b>	<b>Sample Type</b>	<b>Minimum Sampling Frequency</b>
Flow (Total Combined)	MGD	Meter	Continuous [Reference Note 5 following Table E-3]
Ammonia Nitrogen, total (as N)	mg/L	Grab	1/Year
Boron, Total Recoverable	mg/L	Grab	1/Permit Term
Chloramine-T	mg/L	Grab	1/Month During Use

<b>Parameter</b>	<b>Units</b>	<b>Sample Type</b>	<b>Minimum Sampling Frequency</b>
Chloride	mg/L	Grab	1/Permit Term
CTR Priority Pollutants [Reference Note 6 following Table E-3]	µg/L	Grab	Once in year 2027
Dissolved Oxygen	mg/L	Grab	1/Quarter
Electrical Conductivity @ 25°C	µmhos/cm	Grab	1/Month [Reference Note 1 following Table E-3]
Fluoride, Total	mg/L	Grab	1/Year
Formaldehyde	mg/L	Grab	1/Month During Use
Hardness, Total (as CaCO <sub>3</sub> )	mg/L	Grab	1/Month [Reference Note 2 following Table E-3]
Hydrogen Peroxide	mg/L	Grab	1/Month During Use
Nitrate Nitrogen, Total (as N)	mg/L	Grab	1/Year
Nitrogen, Total (as N)	mg/L	Grab	1/Year
Manganese, Total Recoverable	µg/L	Grab	1/Month [Reference Note 2 following Table E-3]
pH	standard units	Grab	1/Month [Reference Note 3 following Table E-3]
Potassium Permanganate	mg/L	Grab	1/Month During Use [Reference Note 2 following Table E-3]
PVP Iodine (iodophor)	mg/L	Grab	1/Month During Use

Parameter	Units	Sample Type	Minimum Sampling Frequency
Settleable Solids	mL/L	Grab	1/Month [Reference Note 4 following Table E-3]
Sulfate, Total (as SO <sub>4</sub> )	mg/L	Grab	1/Permit Term
Temperature	°C	Grab	1/Month
Total Dissolved Solids (TDS)	mg/L	Grab	1/Permit Term
Total Suspended Solids (TSS)	mg/L	Grab	1/Month [Reference Note 4 following Table E-3]

**Table E-3 Notes:**

1. In addition to quarterly monitoring, monitoring for electrical conductivity must be conducted during application of acetic acid, carbon dioxide, sodium bicarbonate, and/or sodium chloride, when the electrical conductivity is expected to be at a maximum.
2. Monitoring for hardness and total recoverable manganese must occur when potassium permanganate is used and must be conducted concurrent with monitoring for potassium permanganate.
3. In addition to quarterly monitoring, monitoring for pH must be conducted during application of acetic acid when the pH of the effluent is expected to be at a minimum, and during the application of carbon dioxide and/or sodium chloride, when the pH expected to be at a maximum.
4. In addition to quarterly monitoring, monitoring for settleable solids and TSS must be conducted during cleaning operations or other operational modes that increase the discharge of solids.
5. Monitoring for total combined flow must be measured at the outfall of the settling pond after the split to the second settling basin and prior to the final splitter box and sluice gate.
6. Those pollutants identified by the California Toxics Rule at 40 C.F.R. section 131.38 and listed in Table J-1.

**4.2. Monitoring Location EFF-002**

4.2.1. The Discharger shall monitor effluent from the Facility at Monitoring Location EFF-002 as described in Table E-4.

4.2.2. The total volume of wastewater discharged must be recorded monthly. For each discharge period, the Discharger must calculate and report the total volume of wastewater discharged within the month and the average flow rate in million gallons per day.

**Table E-4. Effluent Monitoring (EFF-002)**

<b>Parameter</b>	<b>Units</b>	<b>Sample Type</b>	<b>Minimum Sampling Frequency</b>	<b>Required Analytical Test Method</b>
Flow	MGD	Meter	1/Month	Meter
Phosphorous, Total (as P)	mg/L	Grab	1/Quarter	

**4.3. Monitoring Location EFF-003**

- 4.3.1. The Discharger shall monitor effluent from the Facility at Monitoring Location EFF-003 as described in Table E-5.
- 4.3.2. Flow at Monitoring Location EFF-003 must be calculated by subtracting the flow measured at Monitoring Location EFF 002 from the total combined flow measured at Monitoring Location EFF-001.
- 4.3.3. The total volume of wastewater discharged must be recorded monthly. For each discharge period, the Discharger must calculate and report the total volume of wastewater discharged within the month and the average flow rate in million gallons per day.

**Table E-5. Effluent Monitoring (EFF-003)**

<b>Parameter</b>	<b>Units</b>	<b>Sample Type</b>	<b>Minimum Sampling Frequency</b>	<b>Required Analytical Test Method</b>
Flow	MGD	Meter	1/Month	

**5. WHOLE EFFLUENT TOXICITY TESTING REQUIREMENTS – NOT APPLICABLE**

**6. LAND DISCHARGE MONITORING REQUIREMENTS – NOT APPLICABLE**

**7. RECYCLING MONITORING REQUIREMENTS – NOT APPLICABLE**

**8. RECEIVING WATER MONITORING REQUIREMENTS – NOT APPLICABLE**

**9. OTHER MONITORING REQUIREMENTS**

**9.1. Quarterly Drug and Chemical Use Report**

The information listed below must be submitted for all aquaculture drugs or chemicals used at the Facility, including those administered by injection or in medicated feed. This information must be reported at quarterly intervals and submitted with the quarterly SMRs using the drug and chemical usage report table found in Attachment H of this Order.

- 9.1.1. The name(s) and active ingredient(s) of the drug or chemical.
- 9.1.2. The date(s) of application.
- 9.1.3. The purpose(s) for the application.
- 9.1.4. The method of application (e.g., immersion bath, flush, administered in feed, injection), duration of treatment, whether the treatment was static or flush (for drugs or chemicals applied directly to water), amount in gallons or pounds used, treatment concentration(s), treatment unit, location (i.e., incubation building, pond, or raceway) where application was made, and the flow measured in million gallons per day (MGD) in the treatment units.
- 9.1.5. The flow rate through the Facility measured in MGD at Monitoring Location EFF-001.
- 9.1.6. The method of disposal for drugs or chemicals used but not discharged in the effluent.
- 9.1.7. For drugs and chemicals applied directly to water (i.e., immersion bath, "drip" treatment, flush treatment), the estimated concentration in the effluent at the point of discharge. The specific authorized drugs and chemicals that are applied directly to water include the following: acetic acid, carbon dioxide, Chloramine-T, enteric redmouth vaccine, formalin, hydrogen peroxide, MS-222, oxytetracycline hydrochloride, penicillin G potassium, potassium permanganate, PVP Iodine, sodium bicarbonate, sodium chloride, and Vibrio vaccine. Reporting of the estimated effluent concentration is required whenever the drug or chemical is used, even if an effluent sample has been collected. Reporting of the estimated effluent concentration is not required for drugs and chemicals administered by injection or in medicated feed.

The Discharger must use the following formula to calculate concentration (C) at the point of discharge:

C = concentration of chemical or drug at the point of discharge,

$C = (\text{treatment concentration, mg/L}) \times (\text{flow rate in treatment area, MGD}) / (\text{flow rate at point of discharge, MGD})$ .

*Example: Potassium permanganate (KMnO<sub>4</sub>) concentration at point of discharge for a 2.0 mg/L treatment concentration:*

$C = 2.0 \text{ mg/L (KMnO}_4\text{)} \times 0.45 \text{ MGD (flow through treatment area)} / 5.0 \text{ MGD (flow at point of discharge)}$



$C = 2.0 \text{ mg/L} \times 0.09 = 0.18 \text{ mg/L}$  potassium permanganate (KMnO<sub>4</sub>) concentration at the point of discharge.

This information must be submitted quarterly. If the analysis of this chemical use compared with any toxicity testing results or other available information for the therapeutic agent, chemical or anesthetic indicates that the discharge may cause, have the reasonable potential to cause, or contribute to an excursion of a numeric or narrative water quality criterion or objective, the Executive Officer may require site-specific whole effluent toxicity (WET) tests using *Ceriodaphnia dubia* (*C. dubia*).

- 9.1.8. Of the list of approved drugs and chemicals provided in Attachment G to this Order, submit an affirmative list of those specific drugs and chemicals that were not used during the reporting quarter using the Drug and Chemical Non-Use Table provided in Attachment H to this Order.

## 9.2. Feeding and Production

The Discharger must develop an annual report describing the feeding and production for the Facility for the previous calendar year. The annual report must be submitted by **February 1** of each year and include the following information:

- 9.2.1. monthly food usage in pounds for each calendar month, and  
9.2.2. annual production of aquatic animals in pounds per year.

## 9.3. Priority Pollutants Monitoring

Potential discharge of priority pollutants is based on the probability of the pollutants being present in the surface waters supplied or groundwater pumped from source wells, and from data collected from other concentrated aquatic animal production (CAAP) facilities. Data compiled from CAAP facilities, local drinking water wells, and the State Water Board's Groundwater Ambient Monitoring Association (GAMA) database were used to determine the potential for metals and other priority pollutants to occur. Accordingly, the Lahontan Water Board requires sampling and analysis of the influent (Monitoring Location INF-001) and effluent (Monitoring Location EFF-001) for the priority pollutant metals listed in Attachment J at least once per permit cycle. The samples must be analyzed for priority pollutants in the year **2027** and reported to the Lahontan Water Board by **February 1, 2028**, in the Annual SMR and included in the Report of Waste Discharge (ROWD). (Refer to Attachment J for the specific monitoring requirements.)

By **March 1, 2027**, the Discharger must submit a Priority Pollutant Metal Monitoring Plan electronically via California Integrated Water Quality System (CIWQS) submittal outlining reporting levels (RLs), method detection limits (MDLs), and analytical methods for the priority pollutant metals identified in Attachment J. Three months prior to collecting the required Priority Pollutant Metal samples, the Discharger must notify the Lahontan Water Board of the ELAP-certified laboratory

to be used that can conduct the analysis within the holding times specified in the approved methods in 40 C.F.R. part 136.

The Discharger must comply with the monitoring and reporting requirements for the priority pollutant metals as outlined in section 2.3 and 2.4 of the SIP. The maximum required reporting levels for the priority pollutant metals must be based on the Minimum Levels (MLs) contained in Appendix 4 of the SIP, determined in accordance with section 2.4.2 and section 2.4.3 of the SIP. In accordance with section 2.4.2 of the SIP, when there is more than one ML value for a given substance, the Lahontan Water Board must include as RLs, in the Order, all ML values, and their associated analytical methods, listed in Appendix 4 that are below the calculated effluent limitation. The Discharger may select any one of those cited analytical methods for compliance determination. If no ML value is below the effluent limitation, then the Lahontan Water Board must select as the RL, the lowest ML value, and its associated analytical method, listed in Appendix 4 for inclusion in the Order. Table J-1 provides required maximum reporting levels in accordance with the SIP.

#### **9.4. Annual Best Management Practices (BMP) Plan and Storm Water Pollution Prevention Plan (SWPPP) Reporting**

The Discharger must annually (by **February 1** of each year) certify that the BMP Plan for Aquaculture Operations and the Facility SWPPP meet the requirements of this Order and are being implemented as written, or discuss the unmet requirements and indicate, if possible, when a return to compliance will occur. The annual report must include documentation of staff training conducted during the previous calendar year in accordance with Special Provision 6.3.3.1.4 of this Order and the Discharger's BMP Plan. If changes to the BMP Plan or SWPPP are necessary to accurately reflect operations, maintenance, and the management and control of pollutants at the Facility, a revised plan must be submitted to the Lahontan Water Board along with the above information. The annual report must include a specific section providing this analysis and a summary of changes, if any.

#### **9.5. Visual Observations**

- 9.5.1. Within two business days (48 hours) after each qualifying rain event the Discharger must observe and record the presence or absence of floating and suspended materials, a sheen on the surface, discolorations, turbidity, odors, and source(s) of any observed pollutants. These observations must be made at the property line where the channel terminates near the Golf Course Pond 1. Additionally, if storm water co-mingles with effluent flows, the Discharger must include the point of co-mingling in its observations. Visual observations must be submitted in the next quarterly SMR after the observations and summarized in the annual report.
- 9.5.2. Quarterly visual inspections of the Facility must be made to identify any non-storm water discharge and its sources to ensure that BMPs are being implemented and are effective. Any non-storm water discharges observed and

their sources are reported and described in the next quarterly report following the discharge and are summarized in the annual report.

## 10. REPORTING REQUIREMENTS

### 10.1. General Monitoring and Reporting Requirements

- 10.1.1. The Discharger must comply with all Standard Provisions (Attachment D) related to monitoring, reporting, and recordkeeping.
- 10.1.2. The Discharger must submit a summary annual monitoring report. The report must contain all data collected for the year in a table, and both tabular and graphical summaries of the monitoring data obtained during the previous year(s).
- 10.1.3. The Discharger must calculate and report the result of compliance with average monthly and maximum daily effluent limitations, as necessary. Additional samples may be collected to demonstrate compliance.
- 10.1.4. The Discharger must report to the Lahontan Water Board any toxic chemical release data it reports to the State Emergency Response Commission within 15 days of reporting the data to the Commission pursuant to section 313 of the "Emergency Planning and Community Right to Know Act of 1986."
- 10.1.5. For constituents having an Effluent Limitation with a net allowed effluent increase over influent, the Discharger must: (1) collect influent (spring) and effluent samples on the same day, (2) calculate and report the limit for each constituent where an increase over influent is allowed using the following formula, and (3) report compliance with respect to the limit as:  
  
$$\text{Effluent Limit} = \text{Influent Concentration} + \text{Allowed Net Over Influent Concentration}$$
- 10.1.6. For each parameter with an effluent limitation listed in this Order, the Discharger must determine and report compliance with respect to the effluent limitation. The Discharger must determine and report compliance with respect to each receiving water limitation specified in the Order. For parameters with no monitoring required, the Discharger must report "Not Determined."
- 10.1.7. As part of the ROWD submitted in accordance with the cover page of this Order, the Discharger must provide all reported data in an Excel® tabular format that can be used to evaluate compliance with interim and/or final effluent limitations and conduct a reasonable potential analysis. Electronic submittal of data is required to be uploaded into the State Water Board's CIWQS Program. If the State Water Board's Permit Entry Tool does not allow data to be submitted, it must be provided separately.

### 10.2. Self-Monitoring Reports (SMRs)

- 10.2.1. The Discharger must electronically submit SMRs using the State Water Board's [California Integrated Water Quality System \(CIWQS\) Program website](#)

([http://www.waterboards.ca.gov/water\\_issues/programs/ciwqs](http://www.waterboards.ca.gov/water_issues/programs/ciwqs)). The CIWQS website will provide additional information for SMR submittal in the event there will be a planned service interruption for electronic submittal.

10.2.2. The Discharger must report in the SMR the results for all monitoring specified in this MRP under sections 3-9. The Discharger must submit quarterly SMRs including the results of all required monitoring using U.S. EPA-approved test methods or other test methods specified in this Order. SMRs are to include all new monitoring results obtained since the last SMR was submitted. If the Discharger monitors any pollutant more frequently than required by this Order, the results of this monitoring must be included in the calculations and reporting of the data submitted in the SMR.

10.2.3. Monitoring periods and reporting for all required monitoring must be completed according to the following schedule:

**Table E-6.7 Monitoring Periods and Reporting Schedule**

Sampling Frequency	Monitoring Period Begins On	Monitoring Period	SMR Due Date
Continuous	Order effective date	All	Submit with Quarterly SMR
1/Month	Order effective date	1 <sup>st</sup> day of calendar month through last day of calendar month	May 1 August 1 November 1 February 1 of following year
1/Quarter	Order effective date	January 1 through March 31 April 1 through June 30 July 1 through September 30 October 1 through December 31	May 1 August 1 November 1 February 1 of following year
1/Year	Order effective date	January 1 through December 31	February 1 of following year
1/Permit Term	Order effective date	In the year 2027	February 1, 2028

10.2.4. **Reporting Protocols.** The Discharger must report with each sample result the applicable Reporting Level (RL) and the current Method Detection Limit (MDL), as determined by the procedure in 40 C.F.R. part 136. The Discharger must report the results of analytical determinations for the presence of chemical constituents in a sample using the following reporting protocols:

10.2.4.1. Sample results greater than or equal to the RL shall be reported as measured by the laboratory (i.e., the measured chemical concentration in the sample).

- 10.2.4.2. Sample results less than the RL, but greater than or equal to the laboratory's MDL, shall be reported as "Detected, but Not Quantified," or DNQ. The estimated chemical concentration of the sample must also be reported. For the purposes of data collection, the laboratory must write the estimated chemical concentration next to DNQ. The laboratory may, if such information is available, include numerical estimates of the data quality for the reported result. Numerical estimates of data quality may be percent accuracy ( $\pm$  a percentage of the reported value), numerical ranges (low to high), or any other means considered appropriate by the laboratory.
- 10.2.4.3. Sample results less than the laboratory's MDL must be reported as "Not Detected," or ND.
- 10.2.4.4. Dischargers are to instruct laboratories to establish calibration standards so that the ML value (or its equivalent if there is differential treatment of samples relative to calibration standards) is the lowest calibration standard. At no time is the Discharger to use analytical data derived from extrapolation beyond the lowest point of the calibration curve.
- 10.2.4.5. Sample collection date and time, sample analysis date and time, the name of individual(s) who collected the sample, the name of individual(s) who analyzed the sample, sample collection method(s) as listed in 40 C.F.R. part 136, sample analysis method(s) as listed in 40 C.F.R. part 136, sample preservation method(s) used between sample collection and analysis, and applicable QA/QC (Quality Assurance/Quality Control) data will be included with reported analytical results.
- 10.2.5. Compliance Determination.** Compliance with effluent limitations for priority pollutants must be determined using sample reporting protocols defined above and Attachment A. For purposes of reporting and administrative enforcement by the Lahontan Water Board and State Water Board, the Discharger must be deemed out of compliance with effluent limitations if the concentration of the priority pollutant in the monitoring sample is greater than the effluent limitation and greater than or equal to the reporting level (RL).
- 10.2.6. Multiple Sample Data.** When determining compliance with an AMEL or MDEL for priority pollutants and more than one sample result is available, the Discharger must compute the arithmetic mean unless the data set contains one or more reported determinations of "Detected, but Not Quantified" (DNQ) or "Not Detected" (ND). In those cases, the Discharger must compute the median in place of the arithmetic mean in accordance with the following procedure:
- 10.2.6.1. The data set must be ranked from low to high, ranking the reported ND determinations lowest, DNQ determinations next, followed by quantified values (if any). The order of the individual ND or DNQ determinations is unimportant.
- 10.2.6.2. The median value of the data set must be determined. If the data set has an odd number of data points, then the median is the middle value. If the data set has an even number of data points, then the median is the average of the two

values around the middle unless one or both of the points are ND or DNQ, in which case the median value shall be the lower of the two data points where DNQ is lower than a value and ND is lower than DNQ.

10.2.7. The Discharger must submit SMRs in accordance with the following requirements:

10.2.7.1. The Discharger must arrange all reported data in a tabular format. The data must be summarized to clearly illustrate whether the facility is operating in compliance with interim and/or final effluent limitations. The Discharger is not required to duplicate the submittal of data that is entered in a tabular format within CIWQS. When electronic submittal of data is required and CIWQS does not provide for entry into a tabular format within the system, the Discharger must electronically submit the data in a tabular format as an attachment.

10.2.7.2. The Discharger must attach a cover letter to the SMR. The information contained in the cover letter must clearly identify violations of the waste discharge requirements; discuss corrective actions taken or planned; and the proposed time schedule for corrective actions. Identified violations must include a description of the requirement that was violated and a description of the violation.

### **10.3. Discharge Monitoring Reports (DMRs)**

10.3.1. DMRs are U.S. EPA reporting requirements. The Discharger must electronically certify and submit DMRs together with SMRs using Electronic Self-Monitoring Reports module eSMR 2.5 or any upgraded version. Electronic DMR submittal must be in addition to electronic SMR submittal. Information about electronic DMR submittal is available at the [DMR website](http://www.waterboards.ca.gov/water_issues/programs/discharge_monitoring) at: ([http://www.waterboards.ca.gov/water\\_issues/programs/discharge\\_monitoring](http://www.waterboards.ca.gov/water_issues/programs/discharge_monitoring)).

### **10.4. Other Reports**

#### **10.4.1. Hazardous Substance Spill Report:**

In addition to any other reporting requirements, pursuant to CWC section 13271, the Discharger must immediately notify the Governor's Office of Emergency Services (OES) of any hazardous substance discharged into or onto state waters. Pursuant to CWC section 13267, the Discharger must also notify the Lahontan Water Board's Victorville office of any spills reported to OES within 24 hours by telephone. CWC section 13271(a)(3) states that OES will immediately notify the Lahontan Water Board, local health officer, and administrator of environmental health. Immediately means: (1) as soon as there is knowledge of the discharge, (2) as soon as notification is possible, and (3) when notification can be provided without substantially impeding cleanup or other emergency measures. The reportable quantities for hazardous substances are those developed by the U.S. EPA contained in 40 C.F.R. part 302.

10.4.2. **Report of Waste Discharge (ROWD).** The Discharger must file a ROWD in accordance with title 23, California Code of Regulations, as application for re-issuance of waste discharge requirements no later than specified on the first page of the Order. The ROWD must include a delimited formatted file, such as Excel®, that contains all monitored data that include, for each value, constituent, measurement date, measured value, MDL/RL, and measurement units, and analysis method (for the previous permit cycle).

**10.5. Summary of Reports**

The following table summarizes all reports the Discharger is required to submit.

**Table E-8. Summary of Reports**

Report Name	Location of Requirement	Monitoring Period	Due Date
Quarterly Influent and Effluent Monitoring Report; Quarterly Visual Facility Inspection Findings Report		January 1 through March 31 April 1 through June 30 July 1 through September 30 October 1 through December 31	May 1 August 1 November 1 February 1 of following year
Certification of Updated BMP Plan	Order section 6.3.3.1	N/A	180 days after the adoption date
Quarterly Drug and Chemical Use Report	MRP section 9.1	January 1 through March 31 April 1 through June 30 July 1 through September 30 October 1 through December 31	Submit with quarterly SMR
Annual Feeding and Production Report	MRP section 9.2	January 1 through December 31	February 1 of each year
Priority Pollutant Metal Monitoring Plan	MRP section 9.3	N/A	March 1, 2027
Priority Pollutant Metal Monitoring Report	MRP section 9.3	January 1, 2027 through December 31, 2027	February 1, 2028
Annual BMP Plan and SWPP Plan Review and Certification	MRP section 9.4	January 1 through December 31	February 1 of each year

<b>Report Name</b>	<b>Location of Requirement</b>	<b>Monitoring Period</b>	<b>Due Date</b>
Visual Observations	MRP section 9.5	January 1 through March 31 April 1 through June 30 July 1 through September 30 October 1 through December 31	Submit with quarterly SMR
Hazardous Substance Spill Report	MRP section 10.4.1	N/A	Immediately
Report of Waste Discharge (ROWD)	MRP section 10.4.2	N/A	180 days before expiration date
Discharge Monitoring Report Quality Assurance Study	Fact Sheet section 7.5.6	N/A	Upon request of State Water Board



**ATTACHMENT F – FACT SHEET**

1. PERMIT INFORMATION..... F-3

2. FACILITY DESCRIPTION ..... F-5

    2.1. Description of Wastewater Treatment and Controls..... F-6

    2.2. Discharge Points and Receiving Waters ..... F-7

    2.3. Summary of Existing Requirements and SMR Data ..... F-8

    2.4. Compliance Summary..... F-8

    Table F-3. Compliance Summary – Discharge Points 001 and 002 ..... F-8

    2.5. Planned Changes ..... F-9

3. APPLICABLE PLANS, POLICIES, AND REGULATIONS ..... F-9

    3.1. Legal Authorities ..... F-9

    3.2. California Environmental Quality Act (CEQA) ..... F-10

    3.3. State and Federal Laws, Regulations, Policies, and Plans ..... F-10

    3.5. Other Plans, Polices and Regulations..... F-17

4. RATIONALE FOR EFFLUENT LIMITATIONS AND DISCHARGE SPECIFICATIONS ..... F-18

    4.1. Discharge Prohibitions ..... F-19

    4.2. Technology-Based Effluent Limitations ..... F-20

    4.3. Water Quality-Based Effluent Limitations (WQBELs)..... F-23

    4.4. Final Effluent Limitation Considerations ..... F-62

    4.5. Interim Effluent Limitations – Not Applicable..... F-63

    4.6. Land Discharge Specifications – Not Applicable..... F-63

    4.7. Recycling Specifications - Not Applicable ..... F-63

5. RATIONALE FOR RECEIVING WATER LIMITATIONS ..... F-63

    5.1. Surface Water ..... F-63

    5.2. Groundwater ..... F-64

6. RATIONALE FOR PROVISIONS ..... F-65

    6.1. Standard Provisions ..... F-65

    6.2. Special Provisions..... F-65

7. RATIONALE FOR MONITORING AND REPORTING REQUIREMENTS..... F-66

    7.1. Influent Monitoring ..... F-67

        7.1.1. Monitoring Location INF-001 ..... F-67

    7.2. Effluent Monitoring ..... F-67

        7.2.1. Monitoring Location EFF-001 ..... F-67

    7.3. Whole Effluent Toxicity Testing Requirements – Not Applicable..... F-68

    7.4. Receiving Water Monitoring ..... F-68

    7.5. Other Monitoring Requirements ..... F-68

8. PUBLIC PARTICIPATION..... F-70

    8.1. Notification of Interested Parties ..... F-70

    8.2. Written Comments ..... F-70

    8.3. Public Hearing..... F-70

    8.4. Reconsideration of Waste Discharge Requirements..... F-71

    8.5. Information and Copying..... F-71

8.6. Register of Interested Persons.....F-71  
8.7. Additional Information .....F-71

**TABLE OF TABLES**

Table F-1. Facility Information..... F-3  
Table F-2. Historic Effluent Limitations and Monitoring Data – Discharge Points 001 and 002 ..... F-8  
Table F-3. Compliance Summary – Discharge Points 001 and 002..... F-8  
Table F-4. Surface Water Basin Plan Beneficial Uses ..... F-10  
Table F-5. Ground Water Basin Plan Beneficial Uses..... F-11  
Table F-6. Summary of Technology Based Effluent Limitations - Discharge Points 001 and 002 ..... F-23  
Table F-7. Basin Plan Water Quality Objectives for the Mojave River (at Victorville). F-25  
Table F-8. Basin Plan Water Quality Objectives for the West Fork Mojave River (at Lower Narrows)..... F-25  
Table F-9. Reasonable Potential Analysis Summary for Discharge Point 001 ..... F-28  
Table F-10. Concentrations for Drugs and Chemicals Applied Directly to Water ..... F-35  
Table F-11. Summary of RPA for Basin Plan Table 3-20 Parameters (Maximum)..... F-35  
Table F-12. Summary of RPA for Basin Plan Table 3-21 Parameters (90<sup>th</sup> Percentile) .F-36  
Table F-13. Summary of RPA for Basin Plan Table 3-21 Parameters (Annual Average) ..... F-37  
Table F-14. Estimated Effluent Chloramine-T Concentration ..... F-39  
Table F-15. Estimated Effluent Potassium Permanganate Concentration..... F-45  
Table F-16. Estimated Effluent Formaldehyde Concentration (Low Dose Treatment)F-49  
Table F-17. Estimated Effluent Formaldehyde Concentration (High Dose Treatment) ..F-49  
Table F-18. Aquatic Toxicity of Formalin<sup>1</sup>..... F-50  
Table F-19. Short-Term Aquatic Toxicity of Formalin<sup>1</sup>..... F-50  
Table F-20. Estimated Effluent Hydrogen Peroxide Concentration ..... F-52  
Table F-21. Summary of Fluoride Monitoring Data ..... F-57  
Table F-22. Influent and Effluent Fluoride Monitoring Data Between November 2011 and October 2022..... F-57  
Table F-23. Final Effluent Limitation for Fluoride at Discharge Points 001 and 002... F-59

**ATTACHMENT F – FACT SHEET**

As described in section II.B of this Order, the Lahontan Water Board incorporates this Fact Sheet as findings of the Lahontan Water Board supporting the issuance of this Order. This Fact Sheet includes the legal requirements and technical rationale that serve as the basis for the requirements of this Order.

This Order has been prepared under a standardized format to accommodate a broad range of discharge requirements for Dischargers in California. Only those sections or subsections of this Order that are specifically identified as “not applicable” have been determined not to apply to this Discharger. Sections or subsections of this Order not specifically identified as “not applicable” are fully applicable to this Discharger.

**1. PERMIT INFORMATION**

The following table summarizes administrative information related to the facility.

**Table F-1. Facility Information**

WDID	6B360812001
Discharger	California Department of Fish and Wildlife
Name of Facility	Mojave River Fish Hatchery
Facility Address	12550 Jacaranda Avenue Victorville, California, 92395 San Bernardino County
Facility Contact, Title and Phone	Paco Cabral, Hatchery Manager, paco.cabral@wildlife.ca.gov
Authorized Person to Sign and Submit Reports	Paco Cabral, Hatchery Manager, paco.cabral@wildlife.ca.gov
Mailing Address	Same as Facility Address
Billing Address	Same as Facility Address
Type of Facility	Concentrated Aquatic Animal Production/Fish Hatchery (Standard Industrial Classification Code 0921)
Major or Minor Facility	Minor
Threat to Water Quality	2
Complexity	C
Pretreatment Program	N/A

Recycling Requirements	N/A
Facility Permitted Flow	N/A
Typical Facility Flow	8.9 million gallons per day (MGD)
Watershed	Upper Mojave Hydrologic Area
Receiving Water	Mojave River, minor surface waters tributary to the Mojave River, and groundwater
Receiving Water Type	Inland surface water

1.1. California Department of Fish and Wildlife (hereinafter Discharger) is the owner and operator of the Mojave River Fish Hatchery (hereinafter Facility), a cold water concentrated aquatic animal production (CAAP) facility.

For the purposes of this Order, references to the “discharger” or “permittee” in applicable federal and state laws, regulations, plans, or policy are held to be equivalent to references to the Discharger herein.

1.2. The Facility discharges wastewater to the Mojave River and minor surface waters that are tributary to the Mojave River, waters of the United States, within the Upper Mojave Hydrologic Area of the Mojave Hydrologic Unit (CA Department of Water Resources No. 628.20). The Facility is currently regulated by Order No. R6V-2017-0025 and National Pollutant Discharge Elimination System (NPDES) Permit No. CA0102814 adopted on May 11, 2017 and expired on June 30, 2022. This Order was administratively extended until the renewed Order is adopted. Attachment B provides a map of the area around the Facility. Attachment C provides a flow schematic of the Facility.

1.3. When applicable, state law requires dischargers to file a petition with the State Water Board, Division of Water Rights and receive approval for any change in the point of discharge, place of use, or purpose of use of treated wastewater that decreases the flow in any portion of a watercourse. The State Water Board retains separate jurisdictional authority to enforce any applicable requirements under Water Code section 1211. This is not a requirement under the NPDES regulations.

1.4. The Facility was previously regulated by Order R6V-2017-0025 and NPDES Permit No. CA0102814 adopted on May 11, 2017, and expired on June 30, 2022. The Discharger filed a report of waste discharge and submitted an application for reissuance of its waste discharge requirements (WDRs) and NPDES permit on Dec 30, 2021. The application was deemed complete on October 13, 2021.

1.5. Regulations at 40 C.F.R. section 122.46 limit the duration of NPDES permits to a fixed term not to exceed five years. However, pursuant to California Code of Regulations, title 23, section 2235.4, the terms and conditions of an expired permit are automatically continued pending reissuance of the permit if the Discharger complies with all federal NPDES requirements for continuation of expired permits.

## 2. FACILITY DESCRIPTION

The Discharger owns and operates a cold water CAAP facility. The Facility has the capacity to produce between 450,000 and 675,000 pounds (lbs) of rainbow trout and between 15,000 and 22,000 lbs of brown trout. According to the ROWD, the Facility currently produces between 400,000 and 500,000 lbs of rainbow trout annually. According to the ROWD, 34,000 lbs of food are currently being fed during the month of maximum feeding (i.e., June).

The Facility includes six groundwater wells, three aeration towers, six production raceways (A through F), a hatchery building, two recirculating aquaculture systems, and a settling pond.

Six groundwater wells provide water for the Facility, with two to four wells used at a time. Currently, two wells are inactive and unusable. Groundwater is pumped to an aeration tower to increase dissolved oxygen and is then supplied to the production raceways and hatchery building when in operation.

The six production raceways are 1,000 feet long, and each raceway is divided into ten 100-foot long ponds separated by baffles. Fresh groundwater is supplied to Raceways A and B, where younger fish are held. A mix of fresh groundwater and recirculated water is supplied to Raceways C through F (see below for a description of the recirculation water). Water from the first 500 feet of the raceways is diverted to a mid-pond aeration tower, where it is aerated a second time, and then redistributed to the lower 500 feet of the raceways. Wastewater from the production raceways flows to the settling pond.

Aerated groundwater is pumped to the hatchery building, where it is used for egg incubation and hatching in jars and troughs. Hatchery operations typically occur between January and February. Wastewater from the hatchery building is collected in a floor drain that discharges to a pipe beneath the raceways. The pipe directs hatchery building wastewater to a sump where it is then conveyed to the settling pond through an aboveground pipe.

In 2014, the Discharger installed two self-contained recirculating aquaculture systems to provide temporary refuge for various fish species in peril from drought until conditions are deemed adequate for their release. Each recirculating aquaculture system consists of three 500-gallon tanks, recirculation pumps, high-powered ultraviolet light (UV) disinfection, biofiltration for neutralizing nitrogenous waste, and a water chiller to provide optimal conditions. These systems operate using 80 to 100 percent recirculated water with an estimated flow-through of five (5) gallons per minute (gpm). The sand filters are backwashed two to three times per week, using a total of 60 to 100 gallons of water per flush. The effluent discharge from the systems, including filter backwash, are discharged to the settling pond.

Wastewater from the production raceways, hatchery building, and recirculating aquaculture systems is discharged to the settling pond. The settling pond is divided into two basins by a berm that runs through the center of the pond. Each settling basin is triangle-shaped, with a surface area of 18,200 square feet and a depth that

tapers from 12 feet to 16 feet. Wastewater enters the first settling basin on the western side and exits to a “Y” splitter box on the opposite side. From the “Y” splitter box, a portion of the wastewater from the first settling basin is directed to the second settling basin (approximately 1.9 MGD) and the remainder flows through a flow meter and into another splitter box that separates the effluent into two discharges. Wastewater from the second settling basin is pumped to a third aeration tower and is then comingled with fresh groundwater at the head boxes of raceways C through F, where it receives UV disinfection. Valves at the head boxes allow staff to control the ratio of fresh groundwater to recirculation water. Approximately once per permit term, the Discharger must take the aeration tower offline for inspection and maintenance. To complete the inspection, approximately 1,000 gallons is drained through a culvert under the hatchery residence road to a drainage channel where the water percolates within 100 feet.

Current discharges from the Facility can include unused food, fish excrement, and fish health additives to food and water. The Discharger currently uses or has previously used during the term of Order No. R6V-2017-0025 the following drugs and chemicals in the raceways: sodium chloride (salt) as a flush treatment in the raceways and as a fish-cleansing agent to control the spread of fish disease; potassium permanganate to control gill bacteria on fish; hydrogen peroxide to control external parasites; and florfenicol; and oxytetracycline dihydrate as medicated feeds. Aquaculture drugs and chemicals that may be used at the Facility to treat various fish disease and parasitic outbreaks include acetic acid, amoxicillin trihydrate, carbon dioxide, Chloramine-T, Chorulon®, Epson salt, erythromycin, florfenicol, formalin, hydrogen peroxide, Ivermectin, MS-222, Ovaplant®, oxytetracycline hydrochloride, oxytetracycline dihydrate, penicillin G, potassium permanganate, PVP Iodine, SLICE, sodium bicarbonate, sodium chloride, Romet 30, vibrio vaccine (fish are removed via a basket, dipped in vaccine, and then returned to the raceway), and enteric redmouth bacterin (fish are removed via a basket, dipped in vaccine, and then returned to the raceway). These aquaculture drugs and chemicals, prescribed by the Discharger’s Fish Health Laboratory, are to be used on an “as needed” basis to treat various fish disease and parasitic outbreaks. See Attachment G for additional information regarding aquaculture drugs and chemical use.

On January 11, 2010, the Discharger certified that “the use of copper sulfate products has been discontinued at all DFG hatcheries.” Additionally, copper plates are not used on the dam boards at this Facility.

## **2.1. Description of Wastewater Treatment and Controls**

Wastewater from the production raceways, hatchery building, and recirculating aquaculture systems is discharged to the flow-through settling pond, where solids are settled out prior to discharge.

## 2.2. Discharge Points and Receiving Waters

Wastewater diverted from the first settling basin in the “Y” splitter box flows to another splitter box and sluice gate valve system that directs effluent to either the Mojave River at Discharge Point 001 or to a pond on the Bear Valley Golf Course, owned by Bear Valley Country Club/Pacific Golf Management, at Discharge Point 002. Effluent from Discharge Point 002 ultimately reaches the Mojave River as overflow from Spring Valley Lake to the Mojave River and overflow from Horseshoe Lake to the Mojave River at the Lower Narrows after passing through Mojave Narrows Regional Park.

Receiving waters affected by effluent include channels that connect a series of minor surface waters, wetlands, and perennial flows in the Mojave River at the Lower Narrows; subsurface flows in the riparian aquifer under the dry Mojave River bed upstream of the Lower Narrows; and seasonal flows in the Mojave River upstream of the Lower Narrows.

The Mojave River is located within the Upper Mojave Hydrologic Area (Hydrologic Unit No. 628.20) of the Mojave Hydrologic Unit, and the groundwaters of the Upper Mojave River Valley Groundwater Basin (Basin No. 6-42). The Mojave River surface is normally dry with subsurface flows and seasonal surface water runoff.

Effluent discharged at Discharge Point 001 flows through a surface water channel to a series of ponds located on property owned by Victor Valley College, then through a wetland habitat area, over a berm, past a weir, and is eventually discharged into the Mojave River. Some of the water percolates to the riparian aquifer prior to reaching the Mojave River. This channel and associated wetland habitat are considered waters of the United States. As such, the effluent becomes a water of the United States immediately upon discharge at Discharge Point 001.

Approximately 3.3 MGD of effluent is discharged at Discharge Point 002. Effluent discharged at Discharge Point 002 flows through a concrete-lined channel and discharges to Pond 1. Up to 1.5 MGD from Pond 1 may be distributed to a series of six additional ponds for use as irrigation supply water at the golf course. The remaining water is piped to Spring Valley Lake. Effluent mixed with water from additional sources in Spring Valley Lake is discharged directly to the Mojave River upstream of the Lower Narrows or to Pelican Lake. Water from Pelican Lake then flows to Horseshoe Lake. Overflow from Horseshoe Lake flows down a channel that meets the Mojave River at the Lower Narrows. Both Pelican Lake and Horseshoe Lake are located in the flood plain of the Mojave River on property managed by San Bernardino County Mojave Narrows Regional Park. Effluent from Discharge Point 002 also percolates to the riparian aquifer under the Mojave River bed.

While flows are forced to the surface year-round at the Mojave Narrows by uplifted bedrock, flows in the vicinity of the Facility are typically below the surface of the normally dry riverbed. After storm events or snowmelt, water volume in the river may be sufficient to support above ground flows near the Facility, as occurred due to greater than normal precipitation during Winter 2022-2023 and the associated

snow melt. During dry periods, effluent from Discharge Point 001 percolates into the riparian aquifer under the river bed. Even during dry seasons, wetlands and riparian habitat created and maintained by Facility effluent are often present in the Mojave River. Beaver activity in effluent-dominated portions of the effluent channel and riverbed often creates ponds and wetlands in the riverbed that extend beyond Victor Valley Community College property.

**2.3. Summary of Existing Requirements and SMR Data**

Effluent limitations contained in Order No. R6V-2017-0025 for discharges from Discharge Points 001 and 002 (measured at Monitoring Location M-001 as defined in Order No. R6V-2017-0025), and representative monitoring data from the term of Order No. R6V-2017-0025 are presented in the table below:

**Table F-2. Historic Effluent Limitations and Monitoring Data – Discharge Points 001 and 002**

Parameter	Units	Average Monthly	Maximum Daily	Highest Average Monthly Discharge	Highest Daily Discharge
Fluoride, Total	mg/L	--	0.44	--	0.30
Manganese, Total Recoverable	µg/L	50	100	11	11
Formaldehyde	mg/L	0.65	1.3	ND	ND
Hydrogen Peroxide	mg/L	--	1.3	--	ND
Settleable Solids	mL/L	0.1	--	ND	--
Total Suspended Solids (TSS)	mg/L	6.0	15	--	4.5
pH	Standard Units	--	8.5	--	8.65

**2.4. Compliance Summary**

Monitoring data from July 2017 through March 2023 indicated that the Discharger has complied with Order No. R6V-2017-0025. The table below provides alleged violations that were recorded:

**Table F-3. Compliance Summary – Discharge Points 001 and 002**

Date	Description	ID
December 31, 2021	Failed to sample and analyze for the following constituents: [INF-001]-Boron, Chloride, Fluoride, Total Nitrate, Total Nitrogen, Total Sulfate, Total Dissolved	1099842



Date	Description	ID
	Solids; [EFF-001]-Ammonia, Boron, Chloride, Fluoride, Total Nitrate, Total Nitrogen, Sulfate, and Total Dissolved Solids.	
December 31, 2021	Failed to sample and analyze for the following constituents: Ammonia, Boron, Chloride, Fluoride, Total Nitrate, Total Nitrogen, Sulfate, and Total Dissolved Solids.	1099843
December 31, 2019	Annual EFF-001 Sulfate data not reported on Annual report.	1070679
December 5, 2018	EFF-001 annual Sulfate monitoring results not reported for 2018.	1069322

In December 2021, the Discharger failed to sample and analyze various constituents as required for INF-001 and EFF-001. Corrective actions were reported by the Discharger, as the following “Sampling for these constituents will occur in February 2022 as well as the Fall/Winter of 2022 in attempt to provide two data sets approximately one year apart. In the future, the Hatchery will adhere to all scheduled sampling as specified in the Order.”

**2.5. Possible Facility Changes**

The Discharger is planning to construct a new hatchery building in the open area adjacent to the golf course and canal that feeds Spring Valley Lake. The hatchery building is expected to be approximately 80 feet x 60 feet. The water supply for the new hatchery building will be from existing groundwater well #7. A drain will be installed to convey hatchery wastewater to the settling pond. The new hatchery building is not expected to increase the overall flow from the Facility. Upon completion of the new hatchery building, the discharge pipe from the current hatchery building will be capped and the pumping system will be removed. This idea is still “on the table” however, due to scheduling and priorities, the Discharger is unsure as to timeline of construction. These Facility changes are still in the planning phases, are not in the Facility’s permit application, and therefore this NPDES permit does not cover discharges from these theoretical Facility changes.

**3. APPLICABLE PLANS, POLICIES, AND REGULATIONS**

The requirements contained in this Order are based on the requirements and authorities described in this section.

**3.1. Legal Authorities**

This Order serves as WDRs pursuant to article 4, chapter 4, division 7 of the California Water Code (commencing with section 13260). This Order is also issued pursuant to section 402 of the federal Clean Water Act (CWA) and implementing regulations adopted by the U.S. EPA and chapter 5.5, division 7 of the Water Code (commencing with section 13370). It shall serve as an NPDES permit authorizing

the Discharger to discharge into waters of the United States at the discharge location described in Table 1 subject to the WDRs in this Order.

**3.2. California Environmental Quality Act (CEQA)**

Under Water Code section 13389, this action to adopt an NPDES permit is exempt from CEQA, (commencing with section 21100) of Division 13 of the Public Resources Code.

**3.3. State and Federal Laws, Regulations, Policies, and Plans**

**3.3.1. Water Quality Control Plan.** The Lahontan Water Board adopted a Water Quality Control Plan for the Lahontan Region (hereinafter Basin Plan) on March 31, 1995, with subsequent amendments, the most recent occurring on September 22, 2021. The Basin Plan designates beneficial uses, establishes water quality objectives, and contains implementation programs and policies to achieve those objectives for all waters addressed through the plan. Requirements in this Order implement the Basin Plan. In addition, the Basin Plan implements State Water Board Resolution 88-63, which established state policy that all waters, with certain exceptions, should be considered suitable or potentially suitable for municipal or domestic supply. Thus, beneficial uses applicable to the Mojave River and the Lower Narrows of Mojave River Wetlands in the Upper Mojave Hydrologic Area are as follows:

**Table F-4. Surface Water Basin Plan Beneficial Uses**

Discharge Point	Receiving Water Name	Beneficial Use(s)
001	Wetlands tributary to the Mojave River (and shallow groundwater)	Municipal and Domestic Supply (MUN); Agricultural Supply (AGR); Groundwater Recharge (GWR); Water Contact Recreation (REC-1); Noncontact Water Recreation (REC-2); Commercial and Sport Fishing (COMM); Warm Freshwater Habitat (WARM); Cold Freshwater Habitat (COLD); Freshwater Replenishment (FRSH); and Wildlife Habitat (WILD).
002	Spring Valley Lake and other minor surface waters, including wetlands	Municipal and Domestic Supply (MUN); Agricultural Supply (AGR); Groundwater Recharge (GWR); Water Contact Recreation (REC-1); Noncontact Water Recreation (REC-2); Warm Freshwater Habitat (WARM); Cold Freshwater Habitat (COLD); Freshwater Replenishment (FRSH); Wildlife Habitat (WILD); Rare, Threatened, or Endangered Species (RARE); Migration of Aquatic Organisms (MIGR); Water Quality Enhancement (WQE); and Flood Peak Attenuation/Flood Water Storage (FLD).

The Basin Plan also identifies beneficial uses of groundwater that are applicable to all groundwater in the Lahontan Region. Beneficial uses of

specific groundwater basins in the Lahontan Region are designated in Table 2-2 of the Basin Plan. The Facility is located within the Upper Mojave River Valley Basin. Unless otherwise designated by the Lahontan Water Board, all groundwaters are considered suitable, or potentially suitable, for MUN. The beneficial uses applicable to groundwater in the Upper Mojave River Valley Basin are as follows.

**Table F-5. Ground Water Basin Plan Beneficial Uses**

Basin Name	Beneficial Use(s)
Upper Mojave River Valley Groundwater Basin	Municipal and Domestic Supply (MUN); Agricultural Supply (AGR); Industrial Service Supply (IND); Freshwater Replenishment (FRSH); and Aquaculture (AQUA).

3.3.2. **National Toxics Rule (NTR) and California Toxics Rule (CTR).** U.S. EPA adopted the NTR on December 22, 1992, and later amended it on May 4, 1995 and November 9, 1999. About forty criteria in the NTR applied in California. On May 18, 2000, U.S. EPA adopted the CTR. The CTR promulgated new toxics criteria for California and, in addition, incorporated the previously adopted NTR criteria that were applicable in the state. The CTR was amended on February 13, 2001. On May 2, 2017, the State Water Resources Control Board adopted Resolution No. 2017-0027, Part 2 of the Water Quality Control Plan for Inland Surface Waters, Enclosed Bays, and Estuaries of California—Tribal and Subsistence Fishing Beneficial Uses and Mercury Provisions, which was approved by U.S. EPA on July 14, 2017. These rules contain federal water quality criteria for priority pollutants.

3.3.3. **State Implementation Policy.** On March 2, 2000, the State Water Board adopted the Policy for Implementation of Toxics Standards for Inland Surface Waters, Enclosed Bays, and Estuaries of California (State Implementation Policy or SIP). The SIP became effective on April 28, 2000, with respect to the priority pollutant criteria promulgated for California by the U.S. EPA through the NTR and to the priority pollutant objectives established by the Lahontan Water Board in the Basin Plan. The SIP became effective on May 18, 2000, with respect to the priority pollutant criteria promulgated by the U.S. EPA through the CTR. The State Water Board adopted amendments to the SIP on February 24, 2005, that became effective on July 13, 2005. The SIP establishes implementation provisions for priority pollutant criteria and objectives and provisions for chronic toxicity control. Requirements of this Order implement the SIP.

**Other State Board Plans and Policies:** On May 2, 2017, the State Water Resources Control Board adopted Resolution No. 2017-0027, Part 2 of the Water Quality Control Plan for Inland Surface Waters, Enclosed Bays, and Estuaries of California—Tribal and Subsistence Fishing Beneficial Uses and Mercury Provisions, which was approved by U.S. EPA on July 14, 2017. The State Water Board adopted Resolution No. 2020-0044 and Resolution No. 2021-0044, State Policy for Water Quality Control: Toxicity Provisions (“Toxicity Provisions”). The Provisions were approved by the California Office of Administrative Law pursuant

to Government Code section 11353 on April 25, 2022. The Provisions were approved by the U.S. Environmental Protection Agency, consistent with the requirements of section 303(c) of the Clean Water Act and 40 C.F.R. Part 131, on May 1, 2023. The Toxicity Provisions include statewide numeric water quality objectives for both acute and chronic toxicity and a program of implementation to control toxicity.

- 3.3.4. **Alaska Rule.** On March 30, 2000, USEPA revised its regulation that specifies when new and revised state and tribal water quality standards become effective for CWA purposes (65 Fed. Reg. 24641 [April 27, 2000]). New and revised standards submitted to USEPA after May 30, 2000, must be approved by USEPA before being used for CWA purposes. The final rule also provides that standards already in effect and submitted to USEPA by May 30, 2000, may be used for CWA purposes, whether or not approved by USEPA.
- 3.3.5. **Antidegradation Policy.** Federal regulation 40 C.F.R. section 131.12 requires that the state water quality standards include an antidegradation policy consistent with the federal policy. The State Water Board established California's antidegradation policy in State Water Board Resolution 68-16 ("Statement of Policy with Respect to Maintaining High Quality of Waters in California"). Resolution 68-16 is deemed to incorporate the federal antidegradation policy where the federal policy applies under federal law. Resolution 68 16 requires that existing water quality be maintained unless degradation is justified based on specific findings. The Lahontan Water Board's Basin Plan implements, and incorporates by reference, both the State and federal antidegradation policies. The permitted discharge must be consistent with the antidegradation provision of 40 C.F.R. section 131.12 and State Water Board Resolution 68-16.
- 3.3.6. **Anti-Backsliding Requirements.** Sections 402(o) and 303(d)(4) of the CWA and federal regulations at 40 C.F.R. section 122.44(l) restrict backsliding in NPDES permits. These anti-backsliding provisions require that effluent limitations in a reissued permit must be as stringent as those in the previous permit, with some exceptions in which limitations may be relaxed.
- 3.3.7. **Endangered Species Act Requirements.** This Order does not authorize any act that results in the taking of a threatened or endangered species or any act that is now prohibited, or becomes prohibited in the future, under either the California Endangered Species Act (Fish and Game Code, §§ 2050 to 2097) or the Federal Endangered Species Act (16 U.S.C.A. §§ 1531 to 1544). This Order requires compliance with effluent limits, receiving water limits, and other requirements to protect the beneficial uses of waters of the state. The Discharger is responsible for meeting all requirements of the applicable Endangered Species Act.
- 3.3.8. **Consideration of California Water Code Section 106.3.** Water Code section 106.3 establishes a state policy that every human being has the right to safe, clean, affordable, and accessible water adequate for human consumption, cooking, and sanitary purposes, and directs state agencies to consider this policy when adopting regulations pertinent to water uses described in the section,

including the use of water for domestic purposes. This WDR implements effluent limitations and requirements to meet established receiving water objectives that will maintain all designated beneficial uses of water. Therefore, the requirement to consider access to safe, clean, and affordable water has been met in this Order.

- 3.3.9. **Regulation of Aquaculture Drugs and Chemicals.** CAAP facilities produce fish and other aquatic animals in greater numbers than natural stream conditions would allow; therefore, system management is important to ensure that fish do not become overly stressed, making them more susceptible to disease outbreaks. The periodic use of various aquaculture drugs and chemicals is needed to ensure the health and productivity of cultured aquatic stocks and to maintain production efficiency.

Drugs and chemicals used in aquaculture are regulated by the U.S. Food and Drug Administration (FDA) through the Federal Food, Drug, and Cosmetic Act (FFDCA; 21 U.S.C 301-392). FFDCA, the basic food and drug law of the United States, includes provisions for regulating the manufacture, distribution, and the use of, among other things, new animal drugs and animal feed. FDA's Center for Veterinary Medicine (CVM) regulates the manufacture, distribution, and use of animal drugs. CVM is responsible for ensuring that drugs used in food-producing animals are safe and effective and that food products derived from treated animals are free from potentially harmful residues. CVM approves the use of new animal drugs based on data provided by a sponsor (usually a drug company). To be approved by CVM, an animal drug must be effective for the claim on the label, consistently manufactured, and safe when used as directed for (1) treated animals; (2) persons administering the treatment; (3) the environment, including non-target organisms; and (4) consumers. CVM establishes tolerances and animal withdrawal periods as needed for all drugs approved for use in food-producing animals. CVM has the authority to grant investigational new animal drug (INAD) exemptions so that data can be generated to support the approval of a new animal drug.

CAAP facilities may legally obtain and use aquaculture drugs in one of several ways. Some aquaculture drugs and chemicals used at CAAP facilities are approved by the FDA for certain aquaculture uses on certain aquatic species. Others have an exemption from this approval process when used under certain specified conditions. Others are not approved for use in aquaculture but are considered to be of "low regulatory priority" by FDA (hereafter "LRP drug"). FDA is unlikely to take regulatory action related to the use of an LRP drug if an appropriate grade of the chemical or drug is used, good management practices are followed, and local environmental requirements are met (including NPDES Permit requirements). Finally, some drugs and chemicals may be used for purposes, or in a manner not listed on their label (i.e., "extra-label" use), under the direction of licensed veterinarians for the treatment of specific fish diseases. It is assumed that veterinarian-prescribed aquaculture drugs are used as needed for the duration of acute disease outbreaks. Each of these methods of obtaining and using aquaculture drugs is discussed in further detail below.

It is the responsibility of the Discharger to know which aquaculture drugs and chemicals may be used in CAAP facilities in the Lahontan Region under all applicable federal, state, and local regulations and which aquaculture drugs and chemicals may be discharged to waters of the United States and waters of the state in accordance with this Order. A summary of regulatory authorities related to aquaculture drugs and chemicals is outlined below.

**3.3.9.1. FDA Approved New Animal Drugs.** Approved new animal drugs have been screened by the FDA to determine whether they cause significant adverse public health or environmental impacts when used in accordance with label instructions. Currently, there are ten new animal drugs approved by FDA for use in food-producing aquatic species. These ten FDA-approved new animal drugs include the following:

- 3.3.9.1.1. Chorionic gonadotropin (Chorulon®), used for spawning;
- 3.3.9.1.2. Oxytetracycline hydrochloride (Terramycin®), an antibiotic;
- 3.3.9.1.3. Oxytetracycline dihydrate (Terramycin® 200 for fish), an antibiotic;
- 3.3.9.1.4. Sulfadimethoxine-ormetoprim (Romet-30®), an antibiotic;
- 3.3.9.1.5. Tricaine methanesulfonate (MS-222, Finquel® and Tricaine-S), an anesthetic;
- 3.3.9.1.6. Formalin (Formalin-F®, Paracide F® and PARASITE-S®), used as a fungus and parasite treatment;
- 3.3.9.1.7. Sulfamerazine, an antibiotic;
- 3.3.9.1.8. Chloramine-T (HALAMID® Aqua), a disinfectant;
- 3.3.9.1.9. Florfenicol (Aquaflor®), an antibiotic; and
- 3.3.9.1.10. Hydrogen peroxide, used to control fungal and bacterial infections.

Each aquaculture drug in this category is approved by the FDA for use on specific fish species, for specific disease conditions, at specific dosages, and with specific withdrawal times. Product withdrawal times must be observed to ensure that any product used on aquatic animals at a CAAP facility does not exceed legal tolerance levels in the animal tissue. Observance of the proper withdrawal time helps ensure that products reaching consumers are safe and wholesome.

FDA-approved new animal drugs that are added to aquaculture feed must be specifically approved for use in aquaculture feed and issued through a Veterinary Feed Directive (VFD). Drugs approved by FDA for use in feed must be found safe and effective. Approved new animal drugs may be mixed in feed for uses and at levels that are specified in FDA medicated-feed regulations only. It is unlawful to add drugs to feed unless the drugs are approved for such feed use. For example, producers may not top-dress feed with a water-soluble, over-the-counter antibiotic product. Some medicated feeds, such as Romet-30®, may be manufactured only after the FDA has approved a medicated-feed application (FDA Form 1900) submitted by the feed manufacturer.

Aquaculture drugs in this category can only be used under an investigational new animal drug or "INAD" exemption. INAD exemptions are granted by FDA CVM to permit the purchase, shipment, and use of an unapproved new animal drug for investigational purposes. INAD exemptions are granted by FDA CVM with the expectation that meaningful data will be generated to support the approval of a new animal drug by FDA in the future. Numerous FDA requirements must be met for the establishment and maintenance of aquaculture INADs.

There are two types of INADs: standard and compassionate. Aquaculture INADs, most of which are compassionate, consist of two types: routine and emergency. A compassionate INAD exemption is used in cases in which the aquatic animal's health is of primary concern. In certain situations, producers can use unapproved drugs for clinical investigations (under a compassionate INAD exemption) subject to FDA approval. In these cases, CAAP facilities are used to conduct closely monitored clinical field trials. FDA reviews test protocols, authorizes specific conditions of use, and closely monitors any drug use under an INAD exemption. An application to renew an INAD exemption is required each year. Data recording and reporting are required under the INAD exemption in order to support the approval of a new animal drug or an extension of approval for new uses of the drug.

- 3.3.9.3. FDA Unapproved New Animal Drugs of Low Regulatory Priority (LRP) Drugs.** LRP drugs do not require a new animal drug application (NADA) or INAD exemptions from FDA. Further regulatory action is unlikely to be taken by FDA on LRP drugs as long as an appropriate grade of the drug or chemical is used, good management practices are followed, and local environmental requirements are met (such as NPDES Permit requirements contained in this Order). LRP drugs commonly used at CAAP facilities include the following:
- 3.3.9.3.1. Acetic acid, used as a dip at a concentration of 1,000-2,000 mg/L for one to ten minutes as a parasiticide.
  - 3.3.9.3.2. Carbon dioxide gas, used for anesthetic purposes.
  - 3.3.9.3.3. Povidone iodine (PVP) compounds, used as a fish egg disinfectant at rates of 100 mg/L for 30 minutes during egg hardening and 100 mg/L solution for ten minutes after water hardening.
  - 3.3.9.3.4. Sodium bicarbonate (baking soda), used at 142-642 mg/L for five minutes as a means of introducing carbon dioxide into the water to anesthetize fish.
  - 3.3.9.3.5. Sodium chloride (salt), used at 0.5-1% solution for an indefinite period as an osmoregulatory aid for the relief of stress and prevention of shock. Used as 3% solution for ten to thirty minutes as a parasiticide.
  - 3.3.9.3.6. Potassium permanganate is a LRP that regulatory action has been deferred pending further study.

FDA is unlikely to object at present to the use of these LRP drugs if the following conditions are met:

- 3.3.9.3.6.1. The aquaculture drugs are used for the prescribed indications, including species and life stages where specified.
- 3.3.9.3.6.2 The aquaculture drugs are used at the prescribed dosages (as listed above).
- 3.3.9.3.6.3. The aquaculture drugs are used according to good management practices.
- 3.3.9.3.6.4. The product is of an appropriate grade for use in food animals.
- 3.3.9.3.6.5. An adverse effect on the environment is unlikely.

FDA's enforcement position on the use of these substances should be considered neither an approval nor an affirmation of their safety and effectiveness. Based on information available in the future, FDA may take a different position on their use. In addition, FDA notes that classification of substances as new animal drugs of LRP does not exempt CAAP facilities from complying with all other federal, state, and local environmental requirements, including compliance with this Order.

- 3.3.9.4. **Extra-label Use of an Approved Animal Drug.** Extra-label drug use is the actual or intended use of an approved animal drug in a manner that is not in accordance with the approved label directions and no approved animal drug is available for the indication. This includes, but is not limited to, use on species or for indications not listed on the label. Only a licensed veterinarian with an established veterinarian-client-patient-relationship (VCPR) may prescribe extra-label drugs according to Title 21 Code of Federal Regulations section 530 (21 CFR 530). Under the provisions of 21 CFR 530 a licensed veterinarian may consider extra-label drug use in treating food-producing animals if the health of the animals is immediately threatened and if further suffering or death would result from failure to treat the affected animals. CVM's extra-label drug use policy does not allow the use of drugs to prevent diseases (prophylactic use), improve growth rates, or enhance reproduction or fertility. Spawning hormones cannot be used under the extra-label policy. In addition, the veterinarian assumes the responsibility for drug safety and efficacy and for potential residues in the aquatic animals.

#### **3.4. Impaired Water Bodies on the CWA section 303(d) List**

On 26 June 2015, USEPA gave final approval to California's 2012 list of impaired water bodies prepared pursuant to CWA section 303(d), which requires identification of specific water bodies where it is expected that water quality standards will not be met after implementation of technology-based effluent limitations on point sources. Where it has not done so already, the Lahontan Water Board plans to adopt Total Maximum Daily Loads (TMDLs) for pollutants on the 303(d) list. TMDLs establish waste load allocations for point sources and load allocations for non-point sources, and are established to achieve the water quality standards for the impaired water bodies.



The Mojave River from the Mojave Forks Reservoir outlet to the Upper Narrows is listed on the 2012 303(d) list as impaired for fluoride. The source of the fluoride impairment is from natural sources. The Mojave River from the Upper Narrows to the Lower Narrows is listed on the 2012 303(d) list as impaired for fluoride, sulfates, and total dissolved solids. The source of the fluoride impairment is from natural sources. The source of the sulfate impairment is from natural sources and nonpoint sources. The source of the total dissolved solids impairment is unknown. There is no known timeline for the proposed TMDLs for these constituents. Additional studies are needed to verify whether impairment exists and whether a TMDL is needed.

### 3.5. Other Plans, Policies and Regulations

3.5.1. **Title 27.** Title 27 of the California Code of Regulations (hereafter title 27) contains regulatory requirements for the treatment, storage, processing, and disposal of solid waste. As discussed below, this Order requires compliance with the requirements of title 27 for discharges of wastewater to the settling ponds and disposal of solids.

3.5.1.1. **Settling Ponds.** Discharges of wastewater to land, including but not limited to evaporation ponds or percolation ponds, may be exempt from the requirements of title 27, California Code of Regulations, based on section 20090 et seq. The Facility includes settling ponds that may be exempt from title 27 pursuant to section 20090(b), the “wastewater exemption”. The wastewater exemption has the following preconditions for exemption from title 27:

**Wastewater** – Discharges of wastewater to land, including but not limited to evaporation ponds, percolation ponds, or subsurface leach fields if the following conditions are met:

- (1) the applicable [regional water quality control board] has issued WDRs, or waived such issuance;
- (2) the discharge is in compliance with the applicable water quality control plan; and
- (3) the wastewater does not need to be managed...as a hazardous waste...”

The settling ponds meet the preconditions for exemption from title 27 because the Lahontan Water Board has issued a WDR, the discharge is in compliance with the Basin Plan and will remain in compliance with the Basin Plan through compliance with the WDR, and the wastewater discharge is not a hazardous waste.

3.5.1.2. **Solids Disposal.** Special Provision 6.3.4.1 of this Order specifies that collected screenings, sludges, and other solids, including fish carcasses, shall be disposed of in a manner approved by the Executive Officer and consistent with California Code of Regulations, title 27. Acceptable methods of solid waste disposal include disposal at permitted sites (e.g., landfill, composting sites, soil amendment sites) that are operated in accordance with valid WDRs issued by a

Regional Water Board, or located outside of California, unless the waste disposal is exempted from title 27. This Order seeks to clarify that onsite disposal of solid wastes is not authorized unless approved by the Lahontan Water Board in writing. In accordance with Special Provision 6.3.3.1 of this Order, the Discharger's updated Best Management Practices (BMP) Plan due 180 days after the adoption date shall specify BMPs for solid waste management that ensure disposal or land application of wastes is conducted in a manner approved by the Executive Officer or Designee and consistent with requirements in title 27.

- 3.5.2. **Storm Water Requirements.** U.S. EPA promulgated federal regulations for storm water on 16 November 1990 in 40 C.F.R. parts 122, 123, and 124. The State Water Board's Water Quality Order 2014-0057-DWQ, General Permit for Storm Water Discharges Associated with Industrial Activities (NPDES General Order No. CAS000001) does not regulate storm water discharges from CAAP facilities/fish hatcheries. Nevertheless, the Lahontan Water Board finds that industrial wastes in storm water runoff from the Facility may impact water quality. Therefore, this Order includes appropriate requirements to address storm water runoff from the Facility, including prohibitions, visual non-storm water monitoring and reporting, and development and implementation of a Storm Water Pollution Prevention Plan (SWPPP).

#### 4. RATIONALE FOR EFFLUENT LIMITATIONS AND DISCHARGE SPECIFICATIONS

The CWA requires point source dischargers to control the amount of conventional, non-conventional, and toxic pollutants that are discharged into the waters of the United States. The control of pollutants discharged is established through effluent limitations and other requirements in NPDES permits. There are two principal bases for effluent limitations in the Code of Federal Regulations:

- 40 C.F.R. section 122.44(a) requires that permits include applicable technology-based limitations and standards
- 40 C.F.R. section 122.44(d) requires that permits include water quality-based effluent limitations (WQBELs) to attain and maintain applicable numeric and narrative water quality criteria to protect the beneficial uses of the receiving water.

Generally, mass-based effluent limitations ensure that proper treatment, and not dilution, is employed to comply with the final effluent concentration limitations. Section 122.45(f)(1) requires that all Permit limitations, standards or prohibitions be expressed in terms of mass units except under the following conditions: (1) for pH, temperature, radiation or other pollutants that cannot appropriately be expressed by mass limitations; (2) when applicable standards or limitations are expressed in terms of other units of measure; or (3) if in establishing technology-based Permit limitation on a case-by-case basis limitations based on mass are infeasible because the mass or pollutant cannot be related to a measure of production. The limitations, however, must ensure that dilution will not be used as a substitute for treatment.

The limitations in Order R6V-2017-0025, the CTR criteria, and the water quality objectives in the Basin Plan are expressed in concentration units. Mass-based effluent limitations are not included because the final limitations in this Order are based on the limitations in the previous Order, the CTR criteria, and the water quality objectives in the Basin Plan. Instead, concentration-based limitations for pollutants for each discharge point are included in this Order.

#### **4.1. Discharge Prohibitions**

- 4.1.1. The discharge prohibitions established in this Order are from waste discharge prohibitions in the Basin Plan that apply to the entire Lahontan Region (section 4.1) or based on discharge prohibitions specified in the Water Code.
- 4.1.2. As stated in section I.G of Attachment D, Standard Provisions, this Order prohibits bypass from any portion of a treatment facility. Federal Regulations, 40 C.F.R. section 122.41(m), defines “bypass” as the intentional diversion of waste streams from any portion of a treatment facility. This section of the Federal Regulations, 40 C.F.R. section 122.41(m)(4), prohibits bypass unless it is unavoidable to prevent loss of life, personal injury, or severe property damage. In considering the Water Board’s prohibition of bypasses, the State Water Board adopted a precedential decision, Order No. WQO 2002-0015, which cites the Federal Regulations, 40 C.F.R. section 122.41(m), as allowing bypass only for essential maintenance to assure efficient operation.
- 4.1.3. Consistent with Order No. R6V-2017-0025, this Order includes storm water runoff and storm water collection system prohibitions and requirements, including visual observations within 2 business days of a qualifying rain event and quarterly non-storm water inspections.
- 4.1.4. Due to the nature of operations and chemical treatments at the Facility, the effluent generally contains only one known drug or chemical at any given time. Based on a review of the Discharger’s quarterly drug and chemical use reports between 2017 and 2023, Quarter 2, the Discharger did not apply more than one aquaculture drug or chemical at a time within any calendar quarter, except as follows:
  - 2018 Quarter 2: Salt, H<sub>2</sub>O<sub>2</sub> (hydrogen peroxide), and KMnO<sub>4</sub> (potassium permanganate) were applied all within a one week period. H<sub>2</sub>O<sub>2</sub> was applied in two locations on the same day, two days in a row.
  - 2019 Quarter 2: Salt and Formalin were applied approximately two weeks apart. Formalin was applied in three separate locations on the same day.
  - 2019 Quarter 3: KMnO<sub>4</sub> was applied to multiple locations on the same date, several days in a row. Between Quarter 3 and 4, KMnO<sub>4</sub> and Salt were applied approximately a week and half apart.
  - 2019 Quarter 4: Salt and KMnO<sub>4</sub> were alternately applied in the same location, each three times, within a nine day period.

- 2020 Quarter 1: Salt and  $\text{KMnO}_4$  were applied within a three day period.
- 2023 Quarter 2: Salt and  $\text{KMnO}_4$  were alternately applied in the same location, each once a day for a three day period.

Therefore, as discussed further in section 4.3.3 and 4.3.5 of this Fact Sheet, this Order uses a chemical-specific approach to determine “reasonable potential” for discharges of aquaculture drugs and chemicals from the Facility and does not include whole effluent toxicity testing requirements. Some information is available to discern whether application of more than one aquaculture drug or chemical would produce toxic effects; however, defining the multitude of chemicals which could be applied concurrently would result in an even more complex Order. Therefore, this Order prohibits the application of more than one aquaculture drug or chemical to the raceways per treatment period (as defined in Attachment A).

- 4.1.5. This Order includes prohibitions on introduction of any aquaculture drug or chemical not already considered by this Order, or in a manner other than specified in this Order to protect the beneficial uses of the receiving waters and to meet water quality objectives from the Basin Plan.
- 4.1.6. This Order includes storm water runoff and storm water collection system prohibitions and requirements. This Order also establishes a requirement for quarterly non-storm water inspections.

## **4.2. Technology-Based Effluent Limitations**

### **4.2.1. Scope and Authority**

Section 301(b) of the CWA and implementing U.S. EPA permit regulations at 40 C.F.R. section 122.44 require that permits include conditions meeting applicable technology-based requirements at a minimum, and any more stringent effluent limitations necessary to meet applicable water quality standards. The discharge authorized by this Order must meet minimum federal technology-based requirements based on Best Professional Judgment (BPJ) in accordance with 40 C.F.R. section 125.3.

The CWA requires that technology-based effluent limitations be established based on several levels of controls:

- 4.2.1.1. Best practicable treatment control technology (BPT) represents the average of the best existing performance by well-operated facilities within an industrial category or subcategory. BPT standards apply to toxic, conventional, and non-conventional pollutants.
- 4.2.1.2. Best available technology economically achievable (BAT) represents the best existing performance of treatment technologies that are economically achievable within an industrial point source category. BAT standards apply to toxic and non-conventional pollutants.
- 4.2.1.3. Best conventional pollutant control technology (BCT) represents the control from existing industrial point sources of conventional pollutants including BOD,

TSS, fecal coliform, pH, and oil and grease. The BCT standard is established after considering a two-part reasonableness test. The first test compares the relationship between the costs of attaining a reduction in effluent discharge and the resulting benefits. The second test examines the cost and level of reduction of pollutants from the discharge from publicly owned treatment works to the cost and level of reduction of such pollutants from a class or category of industrial sources. Effluent limitations must be reasonable under both tests.

- 4.2.1.4. New source performance standards (NSPS) represent the best available demonstrated control technology standards. The intent of NSPS guidelines is to set limitations that represent state-of-the-art treatment technology for new sources.

The CWA requires U.S. EPA to develop effluent limitations, guidelines and standards (ELGs) representing application of BPT, BAT, BCT, and NSPS. Section 402(a)(1) of the CWA and 40 C.F.R. section 125.3 authorize the use of best professional judgment (BPJ) to derive technology-based effluent limitations on a case-by-case basis where ELGs are not available for certain industrial categories and/or pollutants of concern. Where BPJ is used, the Lahontan Water Board must consider specific factors outlined in 40 C.F.R. section 125.3.

A CAAP facility is defined in 40 C.F.R. section 122.24 as a fish hatchery, fish farm, or other facility that contains, grows, or holds cold water fish species or other cold water aquatic animals including, but not limited to, the Salmonidae family of fish (e.g., trout and salmon) in ponds, raceways, or other similar structures. In addition, the facility must discharge at least 30 calendar days per year, produce at least 20,000 pounds (9,090 kilograms) harvest weight of aquatic animals per year, and feed at least 5,000 pounds (2,272 kilograms) of food during the calendar month of maximum feeding.

A facility that does not meet the above criteria may also be designated a cold water CAAP facility upon a determination that the facility is a significant contributor of pollution to waters of the United States [40 C.F.R. § 122.24(c)]. Cold water, flow-through CAAP facilities are designed to allow the continuous flow of fresh water through tanks and raceways used to produce aquatic animals (typically cold water fish species). Flows from CAAP facilities ultimately are discharged to waters of the United States and of the State. 40 C.F.R. section 122.24 specifies that CAAP facilities are point sources subject to the NPDES program.

The operation of CAAP facilities may introduce a variety of pollutants into receiving waters. USEPA identifies three classes of pollutants: (1) conventional pollutants (i.e., TSS, oil and grease, BOD, fecal coliforms, and pH); (2) toxic pollutants (e.g., metals such as copper, lead, nickel, and zinc and other toxic pollutants); and (3) non-conventional pollutants (e.g., ammonia-N, Formalin, and phosphorus). Some of the most significant pollutants discharged from CAAP facilities are solids from uneaten feed and fish feces that settle to the

bottom of the raceways. Both of these types of solids are primarily composed of organic matter including BOD, organic nitrogen, and organic phosphorus.

Fish raised in CAAP facilities may become vulnerable to disease and parasite infestations. Various aquaculture drugs and chemicals are used periodically at CAAP facilities to ensure the health and productivity of the confined fish population, as well as to maintain production efficiency. Aquaculture drugs and chemicals are used to clean raceways and to treat fish for parasites, fungal growths, and bacterial infections. Aquaculture drugs and chemicals are sometimes used to anesthetize fish prior to spawning or “tagging” processes. As a result of these operations and practices, drugs and chemicals may be present in discharges to waters of the United States or waters of the State.

On August 23, 2004 USEPA published ELGs for the Concentrated Aquatic Animal Production Point Source Category (40 C.F.R. part 451). The ELGs became effective on September 22, 2004. The ELGs establish national technology-based effluent discharge requirements for flow-through and recirculation systems and for net pens based on BPT, BCT, BAT and NSPS. In its proposed rule, published on September 12, 2002, USEPA proposed to establish numeric limitations for a single pollutant –TSS – while controlling the discharge of other pollutants through narrative requirements. In the final rule, however, USEPA determined that, for a nationally applicable regulation, it would be more appropriate to promulgate qualitative TSS limitations in the form of solids control best management practices (BMP) requirements.

In the process of developing the ELGs, USEPA identified an extensive list of pollutants of concern in discharges from the aquaculture industry, including several metals, nutrients, solids, BOD, bacteria, drugs, and residuals of federally registered pesticides. USEPA did not include specific numerical limitations in the ELG for any pollutants on this list, believing that BMPs would provide acceptable control of these pollutants. USEPA did conclude during the development of the ELG that control of suspended solids would also effectively control concentrations of other pollutants of concern, such as BOD, metals and nutrients, because other pollutants are either bound to the solids or are incorporated into them. And, although certain bacteria are found at high levels in effluents from settling basins, USEPA concluded that disinfection is not economically achievable. USEPA also allowed permitting authorities to apply technology-based effluent limitations for other pollutants and WQBELs for pollutants considered in the ELG in order to comply with applicable water quality standards.

#### **4.2.2. Applicable Technology-Based Effluent Limitations**

Technology-based requirements in this Order are based on a combination of application of ELGs for BMP requirements and case-by-case numeric limitations developed using BPJ and retained from Order R6V-2017-0025.

##### **4.2.2.1. Total Suspended Solids (TSS).** Technology-based requirements in this Order are based on a combination of application of the ELGs for BMP requirements

and case-by-case numeric limitations developed using BPJ and carried over from Order R6V 2017-0025. The effluent limitations for TSS, 6.0 mg/L as an average monthly effluent limitation (AMEL) and 15 mg/L as an instantaneous maximum, are continued in this Order from Order R6V-2017-0025. Section 402(o) of the CWA prohibits backsliding of effluent limitations that are based on BPJ to reflect a subsequently promulgated ELG which is less stringent. Removal of the numeric limitations for TSS would constitute backsliding under CWA Section 402(o). These limitations were established prior to the issuance of the ELG and were established as a means of controlling the discharge of solids from algae, silt, fish feces and uneaten feed.

Existing wastewater treatment technology (such as settling basins and vacuum cleaning) is capable of dependably removing solids (primarily fish feces and uneaten feed) from CAAP facility effluent prior to discharge. This Facility utilizes one full-flow settling pond prior to discharge. Existing self-monitoring data show the Facility is able to reliably meet the numeric effluent limitations for TSS using existing wastewater treatment and control technologies, and implementation of BMPs.

This Order does not contain mass effluent limitations for TSS because there are no standards that specifically require a mass-based effluent limitation, and mass of the pollutant discharged is not specifically related to a measure of operation [40 C.F.R. § 122.45(f)(iii)]. This is consistent with Order R6V-2017-0025, which did not include mass effluent limitations.

4.2.2.2. **Flow.** Consistent with Order R6V-2017-0025, this Order does not include an effluent limitation for flow because the Facility’s pumping infrastructure limits the amount of water used at the Facility and because compliance with effluent limitations for TSS and settleable solids ensures that flows exceeding the treatment capacity of the Facility will not be discharged. This Order requires the Discharger to measure the total combined flow from Discharge Points 001 and 002 at Monitoring Location EFF 001.

**Table F-6. Summary of Technology Based Effluent Limitations - Discharge Points 001 and 002**

Parameter	Units	Effluent Limitations			
		Average Monthly	Maximum Daily	Instantaneous Minimum	Instantaneous Maximum
Total Suspended Solids	mg/L	6.0	--	--	15.0

**4.3. Water Quality-Based Effluent Limitations (WQBELs)**

**4.3.1. Scope and Authority**

CWA Section 301(b) and 40 C.F.R. section 122.44(d) require that permits include limitations more stringent than applicable federal technology-based requirements where necessary to achieve applicable water quality standards.

Section 122.44(d)(1)(i) of 40 C.F.R. requires that permits include effluent limitations for all pollutants that are or may be discharged at levels that have the reasonable potential to cause or contribute to an exceedance of a water quality standard, including numeric and narrative objectives within a standard. Where reasonable potential has been established for a pollutant, but there is no numeric criterion or objective for the pollutant, water quality-based effluent limitations (WQBELs) must be established using: (1) U.S. EPA criteria guidance under CWA section 304(a), supplemented where necessary by other relevant information; (2) an indicator parameter for the pollutant of concern; or (3) a calculated numeric water quality criterion, such as a proposed state criterion or policy interpreting the state's narrative criterion, supplemented with other relevant information, as provided in section 122.44(d)(1)(vi).

The process for determining reasonable potential and calculating WQBELs when necessary is intended to protect the designated uses of the receiving water as specified in the Basin Plan, and achieve applicable water quality objectives and criteria that are contained in other state plans and policies, or any applicable water quality criteria contained in the CTR and NTR.

#### 4.3.2. **Applicable Beneficial Uses and Water Quality Criteria and Objectives**

The Basin Plan designates beneficial uses, establishes water quality objectives, and contains implementation programs and policies to achieve those objectives for all waters addressed through the plan. In addition, the Basin Plan implements State Water Board Resolution No. 88-63, which established state policy that all waters, with certain exceptions, should be considered suitable or potentially suitable for municipal or domestic supply.

The federal CWA section 101(a)(2), states: "it is the national goal that wherever attainable, an interim goal of water quality which provides for the protection and propagation of fish, shellfish, and wildlife, and for recreation in and on the water be achieved by July 1, 1983." Federal Regulations, developed to implement the requirements of the CWA, create a rebuttable presumption that all waters be designated as fishable and swimmable. Federal Regulations, 40 C.F.R. sections 131.2 and 131.10, require that all waters of the State be regulated to protect the beneficial uses of public water supply, protection and propagation of fish, shell fish and wildlife, recreation in and on the water, agricultural, industrial and other purposes including navigation. Section 131.3(e), 40 C.F.R., defines existing beneficial uses as those uses actually attained after November 28, 1975, whether or not they are included in the water quality standards. Federal Regulation, 40 C.F.R. section 131.10 requires that uses be obtained by implementing effluent limitations, requires that all downstream uses be protected and states that in no case shall a state adopt waste transport or waste assimilation as a beneficial use for any waters of the United States.

##### 4.3.2.1. **Receiving Water and Beneficial Uses.** The Facility discharges wastewater to the Mojave River and minor surface waters that are tributary to the Mojave



River, waters of the United States. The beneficial uses applicable to the Mojave River in the Upper Mojave Hydrologic Area are presented in Table F-4.

4.3.2.2. **Water Quality Objectives.** The water quality objectives applicable to the receiving water for this discharge are from the Basin Plan; the CTR, established by USEPA at 40 C.F.R. section 131.38; and the NTR, established by USEPA at 40 C.F.R. section 131.36. Some pollutants have water quality objectives established by more than one of these sources.

4.3.2.2.1. **Basin Plan.**

The Basin Plan specifies numeric and narrative water quality objectives for pollutants in order to protect beneficial uses. The narrative toxicity objective states, “*All waters shall be maintained free of toxic substances in concentrations that are toxic to, or that produce detrimental physiological responses in human, plant, animal, or aquatic life.*” The narrative chemical constituents objective states, “*Waters shall not contain concentrations of chemical constituents in amounts that adversely affect the water for beneficial uses.*”

The Basin Plan includes the following site-specific numeric water quality objectives for chloride (Cl), sulfate (SO<sub>4</sub>), fluoride (F), and boron (B), applicable to the Mojave River (at Victorville) in the Mojave River Hydrologic Unit:

**Table F-7. Basin Plan Water Quality Objectives for the Mojave River (at Victorville)**

Surface Water	Statistical Base	Cl	SO <sub>4</sub>	F	B
Mojave River (at Victorville)	Annual Average <sup>1</sup> (mg/L)	75	40	0.2	0.2
Mojave River (at Victorville)	90 <sup>th</sup> Percentile <sup>2</sup> (mg/L)	100	100	1.5	0.3

**Table F-7 Notes:**

1. Arithmetic mean of all data collected in a 1-year period.
2. Only 10 percent of data can exceed this value.

The Basin Plan also includes the following site-specific numeric water quality objectives for total dissolved solids (TDS) and nitrate as nitrate (NO<sub>3</sub> as NO<sub>3</sub>) applicable to the Mojave River (at Lower Narrows). The Lower Narrows are downstream of Discharge Point 001 and flows from Discharge Point 002 enter the Mojave River at the Lower Narrows.

**Table F-8. Basin Plan Water Quality Objectives for the West Fork Mojave River (at Lower Narrows)**

Surface Water	Statistical Base	TDS	NO <sub>3</sub> as NO <sub>3</sub>
Mojave River (at Lower Narrows)	Maximum (mg/L)	312	5

The water quality objectives applicable to the Mojave River, downstream from the hatchery, set forth in Tables 3-20 and 3-21 of the Basin Plan, have been incorporated into the Order as Receiving Water Limitations in section 5.

The Basin Plan also contains water quality objectives that apply to all surface waters (including wetlands) within the Lahontan Region, which are described in pages 3-3 through 3-6 of the Basin Plan. These have been incorporated into the Order as Receiving Water Limitations in section 5.1.

Water quality objectives that apply to all groundwaters within the Lahontan Region are described in pages 3-13 through 3-14 of the Basin Plan. The water quality objectives applicable to the Mojave River Ground Water Basin have been incorporated into the Order as Receiving Water Limitations in section 5.2. because the settling ponds are unlined and thus the hatchery discharges to both surface and groundwater.

4.3.2.2.2 **CTR.** The CTR specifies numeric aquatic life criteria for 23 priority toxic pollutants and numeric human health criteria for 57 priority toxic pollutants. These criteria apply to all inland surface waters and enclosed bays and estuaries. Human health criteria are further identified as for “water and organisms” or for “organisms only.”

4.3.2.2.3 **NTR.** The NTR establishes numeric aquatic life criteria for selenium and numeric human health criteria for 33 toxic organic pollutants.

#### 4.3.3. **Determining the Need for WQBELs**

Assessing whether a pollutant has reasonable potential to exceed a water quality objective in the water body is the fundamental step in determining whether or not a WQBEL is required.

##### 4.3.3.1. **Reasonable Potential Analysis Methodology**

According to SIP section 1.3, the RPA begins with identifying the observed maximum effluent concentration (MEC) for each pollutant based on effluent concentration data. There are three triggers in determining reasonable potential:

- 4.3.3.1.1. Trigger 1 is activated if the MEC is greater than or equal to the lowest applicable water quality objective ( $MEC \geq$  water quality objective), which has been adjusted, if appropriate, for pH, hardness, and translator data. If the MEC is greater than or equal to the adjusted water quality objective, then that pollutant has reasonable potential, and a WQBEL is required.
- 4.3.3.1.2. Trigger 2 is activated if the observed maximum ambient background concentration (B) is greater than the adjusted water quality objective ( $B >$  water quality objective) and the pollutant is detected in any of the effluent samples.

- 4.3.3.1.3. Trigger 3 is activated if a review of other information determines that a WQBEL is required to protect beneficial uses, even though both MEC and B are less than the water quality objective.

To maintain consistency in methodology for permitting discharges of various constituents, the Lahontan Water Board used the same procedures required by the SIP for CTR constituents to evaluate reasonable potential and, where necessary, develop WQBELs for non-CTR constituents. For constituents with no promulgated numeric water quality criteria or objectives, the Lahontan Water Board interpreted narrative objectives from the Basin Plan to establish the basis for reasonable potential and effluent limitation calculations.

#### 4.3.3.2. **Data and Information Used for the RPA**

The following describes the data used to perform an RPA for discharges from Discharge Points 001 and 002.

- 4.3.3.2.1. **Effluent Data.** The effluent monitoring data collected by the Discharger during the term of Order R6V-2017-0025, and the nature of the discharge from Discharge Points 001 and 002 were analyzed to determine if the discharge has reasonable potential. The RPA was based on effluent monitoring data collected by the Discharger between July 2017 and December 2022, priority pollutant metals data collected on August 24, 2021 and September 28, 2022, and additional mercury data collected on March 6, 2023.
- 4.3.3.2.2. **Hardness.** Some freshwater metal objectives are hardness dependent. The lower the hardness, the more stringent the resulting criterion. Effluent hardness data were collected 14 times during the term of Order R6V-2017-0025 and ranged from 74 mg/L to 82 mg/L. The low end of this range was used in the RPA to determine water quality objectives for hardness-dependent metals.
- 4.3.3.2.3. **Ambient Background Data.** The channel and wetlands to which the Facility discharges at Discharge Point 001 is effluent dominated. The golf course ponds, Spring Valley Lake, Horseshoe Lake, and Pelican Lake consist of effluent mixed with water from additional sources. Thus, no physical upstream receiving water monitoring locations exist outside the influence of the discharges. Influent water data collected by the Discharger during the term of Order R6V-2017-0025, which are also representative of upstream receiving water conditions, were analyzed to determine if the discharge has reasonable potential. The RPA was based on influent data collected by the Discharger between July 2017 and December 2022.
- 4.3.3.2.4. **Assimilative Capacity/Mixing Zone.** As no background receiving water exists, no assimilative capacity or mixing zones exist for the discharge from the Facility.
- 4.3.3.3. **Reasonable Potential Analysis for Priority Pollutants.** The MECs and the most stringent applicable water quality objectives used in the RPA are

presented in the following table, along with the RPA results for each pollutant. Most of the pollutants not monitored during the last 5 years were for non-metal priority pollutants that are part of the National Toxic Rule (NTR) and California Toxic Rule (CTR). The last permit did not require all priority pollutants to be collected for the following reasons: 1) previous results did not indicate any pollutants, other than metals, were present and 2) local drinking water wells did not indicate a presence for a number of the remaining constituents.

Review of a nearby drinking water well indicated that a number of the non-metal constituents were still not detected as of 2021, thus collection for all priority pollutants was not required for this permit. However, since the drinking water sampling requirements do not cover the same list of priority pollutants, as the CTR and NTR standards are different, this updated permit will require the collection and analysis for one full set of priority pollutants to be collected once during the permit term.

Based on a review of the influent and effluent data collected during the term of Order R6V-2017-0025, the discharge does not exhibit reasonable potential to cause or contribute to an exceedance of water quality objectives for any priority pollutants.

**Table F-9. Reasonable Potential Analysis Summary for Discharge Point 001**

CTR #	Priority Pollutants	Governing Water Quality Objective, µg/L	MEC or Minimum DL, µg/L	Maximum Background or Minimum DL, µg/L <sup>1,2</sup>	RPA Results <sup>3</sup>
1	Antimony	6.0	<0.09	<0.089	No Limit
2	Arsenic	10	2.0	2.1	No Limit
3	Beryllium	4.0	<0.03	<0.029	No Limit
4	Cadmium	1.9	<0.04	<0.042	No Limit
5a	Chromium (III)	162	Not Available	Not Available	No Limit
5b	Chromium (VI)	11	0.63	0.77	No Limit
6	Copper	7.2	<0.12	<0.23	No Limit
7	Lead	2.2	0.08	<0.083	No Limit
8	Mercury	0.012	0.00044	<0.0001	No Limit
9	Nickel	40	4.7 (DNQ)	<0.16	No Limit
10	Selenium	5.0	<0.07	<0.067	No Limit
11	Silver	2.4	<0.13	<0.13	No Limit
12	Thallium	1.7	<0.02	<0.021	No Limit
13	Zinc	93	<1.70	<1.7	No Limit
14	Cyanide	5.2	<3.80	<3.8	No Limit
15	Asbestos	7.0	Not Available	Not Available	No Limit

<b>CTR #</b>	<b>Priority Pollutants</b>	<b>Governing Water Quality Objective, µg/L</b>	<b>MEC or Minimum DL, µg/L</b>	<b>Maximum Background or Minimum DL, µg/L<sup>1,2</sup></b>	<b>RPA Results<sup>3</sup></b>
16	2,3,7,8-TCDD	0.000000013	Not Available	Not Available	No Limit
17	Acrolein	320	Not Available	Not Available	No Limit
18	Acrylonitrile	0.059	Not Available	Not Available	No Limit
19	Benzene	1.0	Not Available	Not Available	No Limit
20	Bromoform	4.3	Not Available	Not Available	No Limit
21	Carbon Tetrachloride	0.25	Not Available	Not Available	No Limit
22	Chlorobenzene	70	Not Available	Not Available	No Limit
23	Chlorodibromomethane	0.40	Not Available	Not Available	No Limit
24	Chloroethane	No Criteria	Not Available	Not Available	No Limit
25	2-Chloroethylvinyl Ether	No Criteria	Not Available	Not Available	No Limit
26	Chloroform	No Criteria	Not Available	Not Available	No Limit
27	Dichlorobromomethane	0.56	Not Available	Not Available	No Limit
28	1,1-Dichloroethane	5.0	Not Available	Not Available	No Limit
29	1,2-Dichloroethane	0.38	Not Available	Not Available	No Limit
30	1,1-Dichloroethylene	0.057	Not Available	Not Available	No Limit
31	1,2-Dichloropropane	0.52	Not Available	Not Available	No Limit
32	1,3-Dichloropropylene	0.50	Not Available	Not Available	No Limit
33	Ethylbenzene	300	Not Available	Not Available	No Limit
34	Methyl Bromide	48	Not Available	Not Available	No Limit

CTR #	Priority Pollutants	Governing Water Quality Objective, µg/L	MEC or Minimum DL, µg/L	Maximum Background or Minimum DL, µg/L <sup>1,2</sup>	RPA Results <sup>3</sup>
35	Methyl Chloride	No Criteria	Not Available	Not Available	No Limit
36	Methylene Chloride	4.7	Not Available	Not Available	No Limit
37	1,1,2,2-Tetrachloroethane	0.17	Not Available	Not Available	No Limit
38	Tetrachloroethylene	0.80	Not Available	Not Available	No Limit
39	Toluene	150	Not Available	Not Available	No Limit
40	1,2-Trans-Dichloroethylene	10	Not Available	Not Available	No Limit
41	1,1,1-Trichloroethane	200	Not Available	Not Available	No Limit
42	1,1,2-Trichloroethane	0.60	Not Available	Not Available	No Limit
43	Trichloroethylene	2.7	Not Available	Not Available	No Limit
44	Vinyl Chloride	0.50	Not Available	Not Available	No Limit
45	2-Chlorophenol	120	Not Available	Not Available	No Limit
46	2,4-Dichlorophenol	93	Not Available	Not Available	No Limit
47	2,4-Dimethylphenol	540	Not Available	Not Available	No Limit
48	4,6-Dinitro-o-Cresol (aka 2-Methyl-4,6-Dinitrophenol)	13	Not Available	Not Available	No Limit
49	2,4-Dinitrophenol	70	Not Available	Not Available	No Limit
50	2-Nitrophenol	No Criteria	Not Available	Not Available	No Limit
51	4-Nitrophenol	No Criteria	Not Available	Not Available	No Limit
52	3-Methyl-4-Chlorophenol (aka P-chloro-m-Cresol)	No Criteria	Not Available	Not Available	No Limit
53	Pentachlorophenol	0.28	Not Available	Not Available	No Limit

<b>CTR #</b>	<b>Priority Pollutants</b>	<b>Governing Water Quality Objective, µg/L</b>	<b>MEC or Minimum DL, µg/L</b>	<b>Maximum Background or Minimum DL, µg/L<sup>1,2</sup></b>	<b>RPA Results<sup>3</sup></b>
54	Phenol	21,000	Not Available	Not Available	No Limit
55	2,4,6-Trichlorophenol	2.1	Not Available	Not Available	No Limit
56	Acenaphthene	1,200	Not Available	Not Available	No Limit
57	Acenaphthylene	No Criteria	Not Available	Not Available	No Limit
58	Anthracene	9,600	Not Available	Not Available	No Limit
59	Benzidine	0.00012	Not Available	Not Available	No Limit
60	Benzo(a)Anthracene	0.0044	Not Available	Not Available	No Limit
61	Benzo(a)Pyrene	0.0044	Not Available	Not Available	No Limit
62	Benzo(b)Fluoranthene	0.0044	Not Available	Not Available	No Limit
63	Benzo(ghi)Perylene	No Criteria	Not Available	Not Available	No Limit
64	Benzo(k)Fluoranthene	0.0044	Not Available	Not Available	No Limit
65	Bis(2-Chloroethoxy)Methane	No Criteria	Not Available	Not Available	No Limit
66	Bis(2-Chloroethyl)Ether	0.031	Not Available	Not Available	No Limit
67	Bis(2-Chloroisopropyl)Ether	1,400	Not Available	Not Available	No Limit
68	Bis(2-Ethylhexyl)Phthalate	1.8	Not Available	Not Available	No Limit
69	4-Bromophenyl Phenyl Ether	No Criteria	Not Available	Not Available	No Limit
70	Butylbenzyl Phthalate	3,000	Not Available	Not Available	No Limit
71	2-Chloronaphthalene	1,700	Not Available	Not Available	No Limit
72	4-Chlorophenyl Phenyl Ether	No Criteria	Not Available	Not Available	No Limit

<b>CTR #</b>	<b>Priority Pollutants</b>	<b>Governing Water Quality Objective, µg/L</b>	<b>MEC or Minimum DL, µg/L</b>	<b>Maximum Background or Minimum DL, µg/L<sup>1,2</sup></b>	<b>RPA Results<sup>3</sup></b>
73	Chrysene	0.0044	Not Available	Not Available	No Limit
74	Dibenzo(a,h)Anthracene	0.0044	Not Available	Not Available	No Limit
75	1,2-Dichlorobenzene	600	Not Available	Not Available	No Limit
76	1,3-Dichlorobenzene	400	Not Available	Not Available	No Limit
77	1,4-Dichlorobenzene	5.0	Not Available	Not Available	No Limit
78	3,3'-Dichlorobenzidine	0.040	Not Available	Not Available	No Limit
79	Diethyl Phthalate	23,000	Not Available	Not Available	No Limit
80	Dimethyl Phthalate	313,000	Not Available	Not Available	No Limit
81	Di-n-Butyl Phthalate	2,700	Not Available	Not Available	No Limit
82	2,4-Dinitrotoluene	0.11	Not Available	Not Available	No Limit
83	2,6-Dinitrotoluene	No Criteria	Not Available	Not Available	No Limit
84	Di-n-Octyl Phthalate	No Criteria	Not Available	Not Available	No Limit
85	1,2-Diphenylhydrazine	0.040	Not Available	Not Available	No Limit
86	Fluoranthene	300	Not Available	Not Available	No Limit
87	Fluorene	1,300	Not Available	Not Available	No Limit
88	Hexachlorobenzene	0.00075	Not Available	Not Available	No Limit
89	Hexachlorobutadiene	0.44	Not Available	Not Available	No Limit
90	Hexachlorocyclopentadiene	50	Not Available	Not Available	No Limit
91	Hexachloroethane	1.9	Not Available	Not Available	No Limit



CTR #	Priority Pollutants	Governing Water Quality Objective, µg/L	MEC or Minimum DL, µg/L	Maximum Background or Minimum DL, µg/L <sup>1,2</sup>	RPA Results <sup>3</sup>
92	Indeno(1,2,3-cd)Pyrene	0.0044	Not Available	Not Available	No Limit
93	Isophorone	8.4	Not Available	Not Available	No Limit
94	Naphthalene	No Criteria	Not Available	Not Available	No Limit
95	Nitrobenzene	17	Not Available	Not Available	No Limit
96	N-Nitrosodimethylamine	0.00069	Not Available	Not Available	No Limit
97	N-Nitrosodi-n-Propylamine	0.0050	Not Available	Not Available	No Limit
98	N-Nitrosodiphenylamine	5.0	Not Available	Not Available	No Limit
99	Phenanthrene	No Criteria	Not Available	Not Available	No Limit
100	Pyrene	960	Not Available	Not Available	No Limit
101	1,2,4-Trichlorobenzene	5.0	Not Available	Not Available	No Limit
102	Aldrin	0.00013	Not Available	Not Available	No Limit
103	alpha-BHC	0.0039	Not Available	Not Available	No Limit
104	beta-BHC	0.014	Not Available	Not Available	No Limit
105	gamma-BHC	0.019	Not Available	Not Available	No Limit
106	delta-BHC	No Criteria	Not Available	Not Available	No Limit
107	Chlordane	0.00057	Not Available	Not Available	No Limit
108	4,4'-DDT	0.00059	Not Available	Not Available	No Limit
109	4,4'-DDE (linked to DDT)	0.00059	Not Available	Not Available	No Limit
110	4,4'-DDD	0.00083	Not Available	Not Available	No Limit

CTR #	Priority Pollutants	Governing Water Quality Objective, µg/L	MEC or Minimum DL, µg/L	Maximum Background or Minimum DL, µg/L <sup>1,2</sup>	RPA Results <sup>3</sup>
111	Dieldrin	0.00014	Not Available	Not Available	No Limit
112	alpha-Endosulfan	0.056	Not Available	Not Available	No Limit
113	beta-Endosulfan	0.056	Not Available	Not Available	No Limit
114	Endosulfan Sulfate	110	Not Available	Not Available	No Limit
115	Endrin	0.036	Not Available	Not Available	No Limit
116	Endrin Aldehyde	0.76	Not Available	Not Available	No Limit
117	Heptachlor	0.00021	Not Available	Not Available	No Limit
118	Heptachlor Epoxide	0.00010	Not Available	Not Available	No Limit
119-125	PCBs sum (2)	0.00017	Not Available	Not Available	No Limit
126	Toxaphene	0.00020	Not Available	Not Available	No Limit

**Table F-6 Notes:**

1. The MEC and maximum background concentration are the actual detected concentrations unless preceded by a “<” sign, in which case the value shown is the minimum detection level (DL).
2. The MEC or maximum background concentration is “Not Available” when there are no influent monitoring data for the constituent.
3. RPA Results  
 = Limit Required, if MEC > WQO, B > WQO and MEC is detected, or Trigger 3;  
 = No Limit, if MEC and B are < WQO or all effluent data are undetected; or  
 = Undetermined (Ud), if no criteria have been promulgated or there are insufficient data.

**4.3.3.4. Reasonable Potential Analysis for Non-Conventional Pollutants.**

For drugs and chemicals applied directly to water, the numeric value for the protection of beneficial uses are based on site-specific conditions and evaluations (either NOEC, or the No Adverse Effect Level [NOAEL]), to determine the appropriate constituent threshold necessary to interpret the narrative chemical constituent Basin Plan objective. This numeric value, if

available, is specified for each respective drug or chemical applied as listed in the table below:

**Table F-10. Concentrations for Drugs and Chemicals Applied Directly to Water**

Drug/Chemical	Concentration	Basis
Acetic Acid	Not Available	Not Available
Carbon Dioxide	Not Available	Not Available
Chloramine-T	86.3 mg/L	96-hour NOEC for <i>C. dubia</i>
Formalin	1.3 mg/L	96-hour NOAEL for <i>C. dubia</i>
Hydrogen Peroxide	1.3 mg/L	96-hour NOAEL for <i>C. dubia</i>
MS-222	70 mg/L	96-hour NOEC for <i>C. dubia</i>
Oxytetracycline Hydrochloride	40.4 mg/L	96-hour NOAEL for <i>C. dubia</i>
Penicillin G Potassium	350 mg/L	7-day NOEC for <i>P. promelas</i>
Potassium Permanganate	0.1975 mg/L	2-hour NOAEL for <i>C. dubia</i>
PVP Iodine	0.86 mg/L	96-hour NOAEL for <i>C. dubia</i>
Sodium Bicarbonate	Not Available	Not Available
Sodium Chloride	Not Available	Not Available

**4.3.3.4.1. Constituents with No Reasonable Potential**

4.3.3.4.1.1. **Basin Plan Table 3-20 Parameters.** As described in section 4.3.2.2.1. of this Fact Sheet, the Basin Plan contains numeric water quality objectives for the Mojave River at Lower Narrows for TDS and nitrate. These objectives are applied as maximum objectives. To conduct the RPA for these parameters, the Lahontan Water Board evaluated the maximum concentrations of the influent and effluent water. Table F-11 below summarizes the RPA for these pollutants. The tables include the maximum influent and effluent concentrations for each parameter and the applicable water quality objectives from Basin Plan Table 3-20. As shown in the table below, the maximum concentrations are below the applicable objectives for both parameters. This Order includes numeric receiving water limitations for TDS and nitrate based on the Basin Plan objectives, which must be met at the point of discharge from the Facility. This Order also requires monitoring for these parameters.

**Table F-11. Summary of RPA for Basin Plan Table 3-20 Parameters (Maximum)**

Constituent	Maximum Objective, mg/L	EFF-001 Maximum Observed Concentration mg/L	INF-001 Maximum Observed Concentration mg/L	Reasonable Potential?
Total Dissolved Solids (TDS)	312	160	150	No

Constituent	Maximum Objective, mg/L	EFF-001 Maximum Observed Concentration mg/L	INF-001 Maximum Observed Concentration mg/L	Reasonable Potential?
Nitrate as Nitrate (NO <sub>3</sub> as NO <sub>3</sub> )	5	0.9	0.9	No

4.3.3.4.1.2. **Basin Plan Table 3-21 Parameters.** As described in section 4.3.2.2.1. of this Fact Sheet, the Basin Plan contains numeric water quality objectives for the Mojave River at Victorville for chloride, sulfate, fluoride, and boron. These objectives are applied as annual average and 90<sup>th</sup> percentile objectives. To conduct the RPA for these parameters, the Lahontan Water Board evaluated the annual average and 90<sup>th</sup> percentile values of the influent and effluent water. Tables F-12 and F-13 below summarize the RPA for these pollutants. The tables include the annual average and 90<sup>th</sup> percentile values of the influent and effluent for each parameter and the applicable water quality objectives from Basin Plan Table 3-21. As shown in the tables below, the maximum observed effluent 90<sup>th</sup> percentile results are below the applicable objectives for all parameters and the maximum observed annual average results are below the applicable objectives for all parameters, except fluoride (see section 4.3.3.4.2. of this Fact Sheet for a discussion of the RPA results for fluoride). This Order includes numeric receiving water limitations for chloride, sulfate, fluoride, and boron, based on the Basin Plan objectives, which must be met at the point of discharge from the Facility. This Order also requires monitoring for these parameters.

**Table F-12. Summary of RPA for Basin Plan Table 3-21 Parameters (90<sup>th</sup> Percentile)**

Constituent	90 <sup>th</sup> Percentile Objective, mg/L	EFF-001 Maximum Observed 90 <sup>th</sup> Percentile Value, mg/L	INF-001 Maximum Observed 90 <sup>th</sup> Percentile Value, mg/L	Reasonable Potential?
Chloride	100	15.7	13	No
Sulfate	100	12.9	12.9	No
Fluoride	1.5	0.3	0.31	No
Boron	0.3	0.056	0.053	No

**Table F-13. Summary of RPA for Basin Plan Table 3-21 Parameters (Annual Average)**

Constituent	Annual Average Objective, mg/L	EFF-001 Maximum Observed Annual Average Value, mg/L	INF-001 Maximum Observed Annual Average Value, mg/L	Reasonable Potential?
Chloride	75	14.5	13	No
Sulfate	40	13	13	No
Fluoride	0.2	0.3	0.31	Yes
Boron	0.2	0.041	0.053	No

4.3.3.4.1.3. **Acetic Acid, Carbon Dioxide, and Sodium Bicarbonate.** The Discharger does not currently use acetic acid at the Facility, but may use it in the future for the control of external parasites as flush and/or bath treatments. Carbon dioxide gas may be used in bath treatments to anesthetize fish prior to spawning. Sodium bicarbonate, or baking soda, may also be used in bath treatments as a means of introducing carbon dioxide into the water to anesthetize fish. While the discharge of acetic acid, carbon dioxide, or sodium bicarbonate may affect the pH of the receiving water, current effluent and receiving water limitations for pH are adequate to ensure that any potential discharges of acetic acid, carbon dioxide, or sodium bicarbonate do not impact water quality. In addition, carbon dioxide gas added to water will quickly equilibrate with atmospheric carbon dioxide with aeration. However, use and estimated concentrations of these substances must be reported as specified in the MRP (Attachment E).

4.3.3.4.1.4. **Amoxicillin, Erythromycin, Florfenicol, and Romet-30®.** Amoxicillin, erythromycin, florfenicol, and Romet-30® may be used by CAAP facilities. Amoxicillin is injected into fish to control acute disease outbreaks through a veterinarian's prescription for extra-label use. Erythromycin (injected or used in feed formulations) and florfenicol (used in feed formulations) are antibiotics used to control acute disease outbreaks. Erythromycin must be used under an INAD exemption or a veterinarian feed directive. Florfenicol is a NADA approved drug. Romet-30®, also known by the trade name Sulfadimethoxine-oremtroprim, is an antibiotic used in feed formulations and is FDA-approved for use in aquaculture for control of furunculosis in salmonids. Amoxicillin (when injected into fish), erythromycin (when injected into fish or used as a feed additive), florfenicol and Romet-30® (when used as feed additives) are used in a manner that reduces the likelihood of direct discharge of antibiotics to waters of the United States or waters of the state, particularly when CAAP facilities implement BMPs as required by this Order. Accordingly, this Order does not include WQBELs for these

substances. However, use of these substances must be reported as specified in the MRP (Attachment E).

4.3.3.4.1.5. **Chloramine-T.** Chloramine-T (sodium p-toluenesulfonchloramide), also known by the brand name HALAMID® Aqua, is approved through FDA's NADA program as a replacement for copper sulfate and formalin. Chloramine-T is not currently used but may be used by the Discharger in the future as a possible replacement for formalin. The Discharger reports Chloramine-T may be used as a flush or bath treatment at a concentration up to 20 mg/L for 1 hour. Chloramine-T breaks down into para-toluene sulfonamide (pTSA) and, unlike other chlorine-based disinfectants, does not break down into chlorine or form harmful chlorinated compounds.

Results of the Discharger's Pesticide Unit *C. dubia* test, where the test animals were exposed to the toxicant for two hours followed by three exchanges of control water to remove residual compounds and then observed for 96 hours, determined the NOEC and Lowest Observed Effect Concentration (LOEC) to be 86.3 mg/L and 187 mg/L, respectively.

Effluent data for Chloramine-T are not available to assess the impact of Chloramine-T use at the Facility. Therefore, the following information and calculations were used to estimate the effluent Chloramine-T concentrations from flush treatments at Discharge Points 001 and 002. The calculations assume the flow from the raceways mixes completely with the volume of water in the settling basin and is discharged with no further concentration, breakdown, or dilution of Chloramine-T.

The hatchery has six raceways, with a total water flow rate through each raceway estimated at 1.83 cfs. Assuming a retention time of 1 hour, the dilution volume of water from one raceway after 1 hour =  $(1.83 \text{ cfs}) \times (26,930 \text{ gallons/hour}) \times (1 \text{ hour}) = 49,282 \text{ gallons}$  (where 1 cfs = 26,930 gallons/hour). Accordingly, the dilution volume in all 6 raceways =  $6 \times (49,282 \text{ gallons}) = 295,691 \text{ gallons}$ .

The Facility has two settling ponds, each having a surface area of 18,200 square feet and a depth that tapers from 12 to 16 feet. The volume of each settling pond at 18,200 square feet x 14 feet (average between 12 and 16 feet) is 254,800 cubic feet, or 1,906,036 gallons (where 1 cubic foot = 7.48052 gallons). The volume of both settling ponds is therefore estimated to be 3,812,072 gallons.

The total dilution in the six raceways and two settling ponds =  $(295,691 \text{ gallons}) + (3,812,072 \text{ gallons}) = 4,107,763 \text{ gallons}$ .

Flow and volume calculations use the total dilution volume of a 1-hour treatment at 4,107,763 gallons, or 15,549.576 liters (1 gallon = 3.7854118 liters). The Discharger has specified to the Lahontan Water Board that the maximum number of raceways treated per day with Chloramine-T will be two.

Total mass of Chloramine-T applied in milligrams = (# raceways treated) x (treatment time in hours) x (raceway flow in cfs) x (26,930 gallons/hour) x (3.7854118 liters/gallon) x (Chloramine-T concentration in mg/L). The estimated concentrations, based on the number of raceways treated, are summarized in Table F-14.

**Table F-14. Estimated Effluent Chloramine-T Concentration**

Number of Raceways Treated with Chloramine-T	Chloramine-T Treatment Concentration, mg/L	Treatment Time in Hours	Total Mass of Chloramine-T Applied, mg/L	Total Dilution Volume in Liters	Estimated Final Effluent Chloramine-T, mg/L
1	20	1	3,731,046	15,549,576	0.24
2	20	1	7,462,091	15,549,576	0.48
3	20	1	11,193,137	15,549,576	0.72
4	20	1	14,924,183	15,549,576	0.96
5	20	1	32,646,650	15,549,576	2.10
6	20	1	39,175,980	15,549,576	2.52

The estimated final effluent concentration of Chloramine-T at Discharge Points 001 and 002 is 0.24 mg/L if one raceway is treated and 0.48 mg/L if two raceways are treated.

Based on available information regarding Chloramine-T if used at the reported treatment concentrations, Chloramine-T will not be discharged at levels that cause, have the reasonable potential to cause, or will contribute to an excursion of Basin Plan narrative water quality objectives for toxicity. Accordingly, this Order does not include WQBELs for Chloramine-T. However, use and estimated concentrations of Chloramine-T must be reported as specified in the MRP (Attachment E). Effluent monitoring and reporting for Chloramine-T is also required during use. The Lahontan Water Board will review this information, and other information as it becomes available, and this Order may be reopened to establish effluent limitations based on additional use and toxicity information in accordance with the reopener provision in section 6.3.1.2. of this Order.

- 4.3.3.4.1.6. **Chloride and Electrical Conductivity.** Sodium chloride (salt) is used as needed at CAAP facilities as a fish cleansing agent to control parasites, fish disease, and as an osmoregulatory aid to reduce stress amongst the confined fish population. Because dissolved ions in water increase conductivity, the measures of TDS, chloride ion, and conductivity are related. As discussed previously, the Basin Plan contains numeric water quality objectives for TDS in the Mojave River (at Lower Narrows) and chloride in the Mojave River (at Victorville). In addition, the Basin Plan contains a narrative objective for chemical constituents that states, "*Waters designated as AGR shall not contain concentrations of chemical constituents in amounts that adversely affect the water for beneficial uses*"

(i.e., *agricultural purposes*)." Water Quality for Agriculture, Food and Agriculture Organization of the United Nations-Irrigation and Drainage Paper No. 29, Rev. 1 (R.S. Ayers and D.W. Westcot, Rome, 1985), recommends that the conductivity level in waters used for agricultural irrigation not exceed 700  $\mu\text{mhos/cm}$  (Agricultural Water Quality Goal) because it will reduce crop yield for sensitive plants. There are no U.S. EPA water quality criteria for the protection of aquatic organisms for electrical conductivity. Influent and effluent monitoring for electrical conductivity and sodium chloride indicates that the discharge of sodium chloride from the Facility will not cause, have reasonable potential to cause, or contribute to an in-stream excursion of applicable water quality criteria or objectives. This Order requires monitoring for TDS, chloride, and electrical conductivity. Use and estimated concentrations of sodium chloride must also be reported as specified in the MRP (Attachment E). Additionally, because dissolved ions in water increase conductivity, monitoring of electrical conductivity is also required during sodium chloride use as specified in the MRP (Attachment E).

- 4.3.3.4.1.7. **Chorulon®.** Chorulon® may be used by CAAP facilities. Chorulon® is injected into fish to aid in improving spawning function and is a NADA approved drug. Chorulon® (when injected into fish) is used in a manner that reduces the likelihood of direct discharge of this substance to waters of the United States or waters of the state, particularly when CAAP facilities implement BMPs as required by this Order. Accordingly, this Order does not include WQBELs for Chorulon®. However, use of Chorulon® must be reported as specified in the MRP (Attachment E).
- 4.3.3.4.1.8. **Epsom salt.** Epsom salt may be used by CAAP facilities. Epsom salt is used in medicated feed or fish pills to control internal parasites. Epsom salt (when used as a medicated feed or fish pills) is used in a manner that reduces the likelihood of direct discharge of this substance to waters of the United States or waters of the state, particularly when CAAP facilities implement BMPs as required by this Order. Accordingly, this Order does not include WQBELs for Epsom salt. However, use of Epsom salt must be reported as specified in the MRP (Attachment E).
- 4.3.3.4.1.9. **Ivermectin.** Ivermectin may be used by CAAP facilities. Ivermectin is injected into fish to control parasites. Ivermectin (when injected into fish) is used in a manner that reduces the likelihood of direct discharge of this substance to waters of the United States or waters of the state, particularly when CAAP facilities implement BMPs as required by this Order. Accordingly, this Order does not include WQBELs for Ivermectin. However, use of Ivermectin must be reported as specified in the MRP (Attachment E).
- 4.3.3.4.1.10. **Manganese.** The Secondary MCL – Consumer Acceptance Limit for manganese is 50  $\mu\text{g/L}$ , which is incorporated by reference into the Basin Plan chemical constituent objective. The MEC for manganese was 11  $\mu\text{g/L}$



based on 16 samples collected between September 2017 and September 2022. The discharge does not exhibit reasonable potential to cause or contribute to an exceedance of the applicable water quality objective. Accordingly, this Order discontinues WQBELs established in Order R6V-2017-0025 for manganese. However, use of potassium permanganate must be reported as specified in the MRP (Attachment E).

- 4.3.3.4.1.11. **MS-222®**. CAAP facilities use the anesthetic Tricaine methanesulfonate, commonly known as MS-222 (with trade names of Finquel® or Tricaine-S®). MS-222 has been approved by FDA for use as an anesthetic for Salmonidae. Results of toxicity tests using *C. dubia* where the test animals were exposed to MS-222 for two hours, followed by three exchanges of control water to remove residual compound and then observed for 96 hours, determined the NOEC and LOEC to be 70 and 200 mg/L, respectively. MS-222 is generally used as a static treatment bath. The concentration is diluted well below 70 mg/L when discharged at CAAP facilities. Based on available information regarding MS-222 when used according to the reported treatment, MS-222 is not discharged at levels that cause, have the reasonable potential to cause, or will contribute to an excursion of Basin Plan narrative water quality objectives for toxicity. Accordingly, this Order does not include WQBELs for MS-222. However, use and estimated concentrations of MS-222 must be reported as specified in the MRP (Attachment E).
- 4.3.3.4.1.12. **Ovaplant®**. Ovaplant® may be used by CAAP facilities. Ovaplant® is injected into fish to induce gamete maturation and may be used under an INAD exemption. Ovaplant® (when injected into fish) is used in a manner that reduces the likelihood of direct discharge of this substance to waters of the United States or waters of the state, particularly when CAAP facilities implement BMPs as required by this Order. Accordingly, this Order does not include WQBELs for Ovaplant®. However, use of Ovaplant® must be reported as specified in the MRP (Attachment E).
- 4.3.3.4.1.13. **Oxytetracycline Dihydrate and Oxytetracycline Hydrochloride**. Oxytetracycline dihydrate and oxytetracycline hydrochloride, also known by the brand names Terramycin 200® and Terramycin®, are antibiotics approved through FDA's NADA program for use in controlling ulcer disease, furunculosis, bacterial hemorrhagic septicemia, and pseudomonas disease in salmonids. CAAP facilities use the antibiotics during disease outbreaks. Oxytetracycline dihydrate and oxytetracycline hydrochloride are most commonly used at CAAP facilities as feed additives. However, oxytetracycline hydrochloride may also be used as an extra-label use under a veterinarian's prescription in an immersion bath of approximately six to eight hours in duration. Because oxytetracycline hydrochloride may be applied in an immersion bath for up to eight hours at a time, the Lahontan Water Board considered the results of acute and chronic aquatic life toxicity testing conducted by the Discharger's Pesticide Unit when determining

whether WQBELs for oxytetracycline hydrochloride used in an immersion bath treatment were necessary. Results of acute toxicity tests using *C. dubia* showed a 96-hour NOAEL of 40.4 mg/L. Results of chronic toxicity tests using *C. dubia* showed a seven-day NOEC for reproduction of 48 mg/L.

The information available regarding use and discharge of oxytetracycline hydrochloride at CAAP facilities indicates that it is discharged at levels well below the lowest NOEC and NOAEL. The Lahontan Water Board determined that oxytetracycline dihydrate, when used in feed, and oxytetracycline hydrochloride, when used in feed or in an immersion bath treatment, is not discharged at levels that cause, have the reasonable potential to cause, or contribute to an excursion of a narrative water quality objective for toxicity from the Basin Plan. Accordingly, this Order does not include WQBELs for oxytetracycline dihydrate or oxytetracycline hydrochloride. However, use of these substances must be reported as specified in the MRP (Attachment E). When used as an immersion bath, the estimated effluent concentrations of oxytetracycline hydrochloride must be reported as specified in the MRP (Attachment E). The Lahontan Water Board will review this information, and other information, as it becomes available, and this Order may be reopened to establish effluent limitations based on additional use and toxicity information in accordance with the reopener provision in section 6.3.1.2. of this Order.

- 4.3.3.4.1.14. **Penicillin-G.** Penicillin G is an antibiotic used for the control of bacterial infections and is administered as a six to eight hour immersion bath treatment. Penicillin G is not approved under FDA's NADA program and its extra-label use in aquaculture requires a veterinarian's prescription. Due to the length of treatment time, the Lahontan Water Board considered the results of acute and chronic aquatic life toxicity testing conducted by the Discharger's Pesticide Unit when determining whether WQBELs for Penicillin G were necessary in this Order. Results of acute toxicity tests using *C. dubia* showed a 96-hour NOAEL of 890 mg/L. Results of seven-day chronic toxicity testing using *P. promelas* showed seven-day NOEC for survival of 350 mg/L. Based on the information available Penicillin G is discharged at levels well below the lowest NOEC and NOAEL at CAAP facilities. Therefore, the Lahontan Water Board determined that Penicillin G, when used in an immersion bath treatment, is not discharged at levels that cause, have the reasonable potential to cause, or contribute to an excursion of a narrative water quality objective for toxicity from the Basin Plan. Accordingly, this Order does not include WQBELs for Penicillin G. However, use and estimated effluent concentrations of Penicillin G must be reported as specified in the MRP (Attachment E). The Lahontan Water Board will review this information, and other information, as it becomes available, and this Order may be reopened to establish effluent limitations based on

additional use and toxicity information in accordance with the reopener provision in section 6.3.1.2. of this Order.

4.3.3.4.1.15. **Potassium Permanganate.** Potassium permanganate (also known by the trade name of Cairox™) is used at the Facility to control gill disease, bacteria, and parasites. Potassium permanganate has a low estimated lifetime in the environment, being readily converted by oxidizable materials to insoluble manganese dioxide (MnO<sub>2</sub>). In nonreducing and nonacidic environments, MnO<sub>2</sub> is insoluble and has a very low bioaccumulative potential. In addition, potassium permanganate is rapidly converted to insoluble manganese dioxide under hatchery conditions. Potassium permanganate is a special category drug the FDA calls "regulatory action deferred."

Results of acute toxicity tests conducted by the Discharger's Pesticide Unit using *C. dubia* showed a 96-hour NOEC of 0.038 mg/L and a 2-hour NOEC of 0.1975 mg/L.

Potassium permanganate is used at the Facility as a flush treatment at a rate of 2 ounces per cubic feet per second (cfs) of raceway flow, or as a bath treatment of 2 mg/L or less for one hour. The following information and calculations were used to determine the estimated effluent potassium permanganate concentration from flush treatments at Discharge Points 001 and 002. The calculations assume the flow from the raceways mixes completely with the volume of water in the settling basin and is discharged with no further concentration, breakdown, or dilution of potassium permanganate.

The hatchery has six raceways, with a total water flow rate through each raceway estimated at 1.83 cfs. The dimensions of each raceway are 1,000 feet long x 10 feet wide x 3 feet deep. Based on these dimensions, the volume of each raceway is 30,000 cubic feet. With a flow of 1.83 cfs, the estimated hydraulic retention time is approximately 4.55 hours (30,000 cubic feet / 1.83 cfs = 16,393 seconds = 4.55 hours). Assuming a retention time of 4.55 hours, the dilution volume of water from one raceway after 4.55 hours = (1.83 cfs) x (26,930 gallons/hour) x (4.55 hours) = 224,233 gallons (where 1 cfs = 26,930 gallons/hour). Accordingly, the dilution volume in all 6 raceways = 6 x (224,233 gallons) = 1,345,396 gallons.

The Facility has two settling ponds, each having a surface area of 18,200 square feet and a depth that tapers from 12 to 16 feet. The volume of each settling pond at 18,200 square feet x 14 feet (average between 12 and 16 feet) is 254,800 cubic feet, or 1,906,036 gallons (where 1 cubic foot = 7.48052 gallons). The volume of both settling ponds is therefore estimated to be 3,812,072 gallons.

The total dilution in the six raceways during 4.55 hours of flow and two settling ponds = (1,345,396 gallons) + (3,812,072 gallons) = 5,157,468 gallons.

Flow and volume calculations use the total dilution volume from 4.55 hours of flow at 5,157,468 gallons, or 19,523,140 liters (1 gallon = 3.7854118 liters). The Discharger has specified to the Lahontan Water Board that it does not treat more than one raceway at a time with potassium permanganate.

Total mass of potassium permanganate applied in pounds = (# raceways treated) x (rate of use in ounces per cfs) x (raceway flow in cfs) x (0.0625 pounds per ounce). Total dilution volume in million pounds = (total volume in gallons) x (1 million gallons/1,000,000 gallons) x (8.34 pounds per gallon). The estimated concentrations in (ppm = mg/L), based on the number of raceways treated, are summarized in Table F-15.

**Table F-15. Estimated Effluent Potassium Permanganate Concentration**

<b>Number of Raceways Treated with KMnO<sub>4</sub></b>	<b>KMnO<sub>4</sub> Treatment Rate, ounces per cfs</b>	<b>Raceway Flow, cfs</b>	<b>Total Mass of KMnO<sub>4</sub> Applied, pounds</b>	<b>Total Dilution Volume, gallons</b>	<b>Estimated Final Effluent KMnO<sub>4</sub>, mg/L</b>
1	2	1.83	0.22875	5,157,467.87	0.005
2	2	1.83	0.45750	5,157,467.87	0.011
3	2	1.83	0.68625	5,157,467.87	0.016
4	2	1.83	0.91500	5,157,467.87	0.021
5	2	1.83	1.14375	5,157,467.87	0.027
6	2	1.83	1.37250	5,157,467.87	0.032

The estimated final effluent concentration of potassium permanganate at Discharge Points 001 and 002 is 0.005 mg/L if one raceway is treated and 0.032 mg/L if six raceways are treated. Effluent concentrations could not be estimated from the disposal bath treatment wastewaters as information regarding volumes and location of disposal (which affects dilution factors) was unavailable. However, effluent potassium permanganate concentrations from the disposal bath treatments wastewater are likely to be even lower than the concentrations estimated for flush treatments, due to the smaller quantities of wastewater and lower concentrations used in bath treatments (2 mg/L).

Total recoverable manganese was sampled in the effluent 16 times between September 2017 and September 2020 with concentrations ranging from non-detect to 11 µg/L. Potassium concentrations were significantly higher, indicating that the limiting component of potassium permanganate is manganese. Accordingly, maximum potassium permanganate concentrations were calculated from manganese concentrations as follows:  $(\mu\text{g/L Mn}) \times (1 \text{ g Mn} / 1,000,000 \mu\text{g Mn}) \times (1 \text{ mol Mn} / 54.94 \text{ g Mn}) \times (1 \text{ mol KMnO}_4 / 1 \text{ mol Mn}) \times (158.04 \text{ g KMnO}_4 / 1 \text{ mol KMnO}_4) \times (1,000 \text{ mg KMnO}_4 / 1 \text{ g KMnO}_4) = (\text{mg/L KMnO}_4)$ . The MEC of potassium permanganate was determined to be 0.032 mg/L, which is below the water quality objective of 0.1975 mg/L.

Based on available information regarding potassium permanganate if used at the reported treatment concentrations, potassium permanganate will not be discharged at levels that cause, have the reasonable potential to cause, or will contribute to an excursion of Basin Plan narrative water quality objectives for toxicity. Accordingly, this Order does not include WQBELs for potassium permanganate. However, use and estimated concentrations of potassium permanganate must be reported as specified in the MRP (Attachment E). Effluent monitoring and reporting for potassium permanganate is also required during use. The Lahontan Water Board will review this information, and other information as it becomes available, and this Order may be reopened to establish effluent limitations based on additional use and toxicity information in accordance with the reopener provision in section 6.3.1.2. of this Order.

- 4.3.3.4.1.16. **PVP Iodine.** PVP Iodine (Argentyne) is a solution composed of 10 percent PVP Iodine Complex and 90 percent inert ingredients. The FDA considers PVP Iodine an LRP drug for use in aquaculture. PVP Iodine is not currently used but may be used by the Discharger in the future as an egg disinfectant and fungicide. Because PVP Iodine typically is applied in short-term treatments of one hour or less, results of acute aquatic life toxicity testing conducted by the Discharger's Pesticide Unit were considered when determining whether WQBELs for PVP Iodine are necessary in this Order. Results of a single acute toxicity test with *C. dubia* showed a 96- hour NOAEL of 0.86 mg/L. This Order does not include WQBELs for PVP Iodine. However, use and estimated concentrations of PVP Iodine must be reported as specified in the MRP (Attachment E). Effluent monitoring and reporting for PVP Iodine is also required during use. The Lahontan Water Board will review this information, and other information, as it becomes available, and this Order may be reopened to establish effluent limitations based on additional use and

toxicity information in accordance with the reopener provision in section 6.3.1.2. of this Order.

4.3.3.4.1.17. **SLICE.** The drug SLICE (Emamectin benzoate 0.2 percent Aquaculture premix) may be used by CAAP facilities to treat *Salmincola californiensis* (copepods) in finfish. SLICE must be used under an INAD exemption. SLICE is used in a manner that reduces the likelihood of direct discharge to waters of the United States or waters of the state, particularly when CAAP facilities implement BMPs as required by this Order. Medicated feed is prepared by coating SLICE Premix onto the surface of non-medicated fish feed pellets. Feeding occurs to ensure the food is consumed and then metabolized by the fish. This Order does not include WQBELs for SLICE; however, use of SLICE must be reported as specified in the MRP (Attachment E)

4.3.3.4.1.18. **Vibrio Vaccine and Enteric Redmouth Bacterin.** The Discharger has not used Vibrio vaccine or enteric redmouth bacterin, but use may be required in the future to treat enteric redmouth disease. Enteric redmouth (or yersiniosis) bacterins are formulated from inactivated *Yersinia ruckeri* bacteria and are used as an immersion to help protect salmonid species from enteric redmouth disease caused by *Yersinia ruckeri*. These bacterins stimulate the fish's immune system to produce protective antibodies. Vibrio vaccine is used as an immersion and helps protect salmonid species from vibriosis disease caused by *Vibrio anguillarum* serotype I and *Vibrio ordalii*. Vibrio vaccine stimulates the fish's immune system to produce protective antibodies, helping the animal defend itself against vibriosis.

Vibrio vaccine and enteric redmouth bacterin are licensed for use by the U.S. Department of Agriculture's (USDA's) Center for Veterinary Biologics. According to USDA, most biologics leave no chemical residues in animals and most disease organisms do not develop resistance to the immune response by a veterinary biologic. Based upon available information regarding the use of these substances at CAAP facilities, the Lahontan Water Board does not believe that vibrio vaccine or enteric redmouth bacterins, when used according to label and veterinarian instructions, are discharged at levels that cause, have the reasonable potential to cause, or contribute to an excursion of Basin Plan narrative water quality objectives for toxicity. Accordingly, this Order does not include WQBELs for these substances. However, use of these substances must be reported as specified in the MRP (Attachment E).

#### 4.3.3.4.2. **Constituents with Reasonable Potential**

4.3.3.4.2.1. **Fluoride.** As discussed in section 4.3.4.2.1. of this Fact Sheet, the MEC for fluoride was 0.30 mg/L based on 6 samples collected between December 2017 and October 2022, which exceeds the applicable Basin Plan objective from Table 3-21 of 0.2 mg/L. Upstream receiving water concentrations in the Mojave River ranged from 0.27 mg/L to 0.31 mg/L based on 6 samples collected between December 2017 and October 2022. The Mojave River in the vicinity of the discharges from the Facility is listed as impaired for fluoride. Based on the effluent fluoride concentrations, the Lahontan Water Board finds that the discharge has reasonable potential to cause or contribute to an exceedance of the water quality objective and effluent limitations are required. As discussed further in section

4.3.4.2.1. of this Fact Sheet, this Order includes effluent limitations for fluoride that allow for intake credits, because the Discharger has no control over the influent supply water.

4.3.3.4.2.2. **Formaldehyde (Formalin).** Formalin, a solution typically 37 percent by weight formaldehyde, (also known by the trade names FormalinF®, Paracide-F®, PARASITE-S®) is FDA-approved for use in CAAP facilities for controlling external protozoa and monogenetic trematodes on fish, and for controlling fungi of the family Saprolegniaceae in food-producing aquatic species. Formalin is used as a treatment for controlling external parasites in raceways where it would be discharged to surface waters. Formalin treatments are usually utilized as a batch or flush treatment which result in discharges between 3 and 8 hours. For control of other fungi, formalin may be used under an INAD exemption. Formalin can also be used as a "drip" treatment to control fungus on fish eggs at a concentration of 2,000 mg/L formalin, or less, for 15 minutes.

The Discharger did not report formalin use at the Facility during the term of Order R6V-2017-0025. Effluent formaldehyde data are not available to assess the impact of formalin use at the Facility. Therefore, the following information and calculations were used to estimate the effluent formaldehyde concentrations from flush treatments at Discharge Points 001 and 002. The calculations assume the flow from the raceways mixes completely with the volume of water in the settling basin and is discharged with no further concentration, breakdown, or dilution of formaldehyde.

The hatchery has six raceways, with a total water flow rate through each raceway estimated at 1.83 cfs. The dimensions of each raceway are 1,000 feet long x 10 feet wide x 3 feet deep. Based on these dimensions, the volume of each raceway is 30,000 cubic feet. With a flow of 1.83 cfs, the estimated hydraulic retention time is approximately 4.55 hours (30,000 cubic feet / 1.83 cfs = 16,393 seconds = 4.55 hours). Assuming a retention time of 4.55 hours, the dilution volume of water from one raceway after 4.55 hours = (1.83 cfs) x (26,930 gallons/hour) x (4.55 hours) = 224,233 gallons (where 1 cfs = 26,930 gallons/hour). Accordingly, the dilution volume in all 6 raceways = 6 x (224,233 gallons) = 1,345,396 gallons.

The Facility has two settling ponds, each having a surface area of 18,200 square feet and a depth that tapers from 12 to 16 feet. The volume of each settling pond at 18,200 square feet x 14 feet (average between 12 and 16 feet) is 254,800 cubic feet, or 1,906,036 gallons (where 1 cubic foot = 7.48052 gallons). The volume of both settling ponds is therefore estimated to be 3,812,072 gallons.

The total dilution in the six raceways during 4.55 hours of flow and two settling ponds = (1,345,396 gallons) + (3,812,072 gallons) = 5,157,468 gallons.

Flow and volume calculations use the total dilution volume from 4.55 hours of flow at 5,157,468 gallons, or 19,523,140 liters (1 gallon = 3.7854118 liters).

Total mass of formaldehyde applied in milligrams = (# raceways treated) x (treatment time in hours) x (raceway flow in cfs) x (26,930 gallons/hour) x (3.7854118 liters/gallon) x (formalin concentration in mg/L). Formalin can be used in a low dose (25 parts per million [ppm] formalin) or high dose



(50-250 ppm). As the formalin solution is 37 percent formaldehyde, a 25 ppm dose would have a concentration of 9.25 mg/L formaldehyde, and a 250 ppm dose would have a concentration of 92.5 mg/L formaldehyde. The estimated concentrations for the low dose and high dose treatments, based on the number of raceways treated, are summarized in Tables F-13 and F-14.

**Table F-16. Estimated Effluent Formaldehyde Concentration (Low Dose Treatment)**

Number of Raceways Treated with Formalin	Formalin Treatment Concentration, mg/L	Treatment Time in Hours	Total Mass of Formalin Applied, mg	Total Dilution Volume in Liters	Estimated Final Effluent Formalin, mg/L
1	9.25	1	13,804,869	19,523,140	0.71
2	9.25	1	27,609,738	19,523,140	1.41
3	9.25	1	41,414,607	19,523,140	2.12
4	9.25	1	55,219,477	19,523,140	2.83
5	9.25	1	69,024,346	19,523,140	3.54
6	9.25	1	82,829,215	19,523,140	4.24

**Table F-17. Estimated Effluent Formaldehyde Concentration (High Dose Treatment)**

Number of Raceways Treated with Formalin	Formalin Treatment Concentration, mg/L	Treatment Time in Hours	Total Mass of Formalin Applied, mg	Total Dilution Volume in Liters	Estimated Final Effluent Formalin, mg/L
1	92.5	1	17,256,086	19,523,140	0.88
2	92.5	1	34,512,173	19,523,140	1.77
3	92.5	1	51,768,259	19,523,140	2.65
4	92.5	1	69,024,346	19,523,140	3.54
5	92.5	1	86,280,432	19,523,140	4.42
6	92.5	1	103,536,519	19,523,140	5.30

The State Water Board, Division of Drinking Water (DDW) does not have a maximum contaminant level (MCL) for formaldehyde; however, the historic DDW Drinking Water Action Level is listed as 0.1 mg/L based on calculation by standard risk assessment methods, with a Modifying Factor equal to ten. The U.S. EPA Integrated Risk Information System (IRIS) lists a reference dose of 1.4 mg/L as a drinking water level. There are no recommended criteria for formaldehyde for the protection of aquatic life.

The Discharger’s Pesticide Unit conducted biotoxicity studies to determine the aquatic toxicity of formalin using *P. promelas* and *C. dubia*. A summary of the data submitted follows:

**Table F-18. Aquatic Toxicity of Formalin<sup>1</sup>**

Species	7-day LC50, mg/L	LOEC, mg/L	NOEC, mg/L	LOAEL, mg/L	NOAEL, mg/L
<i>C. dubia</i>	2.43	5.8 (survival) 1.3 (reproduction)	1.3 (survival) <1.3 (reproduction)	5.8	1.3
<i>P. promelas</i>	23.3	9.09	2.28	--	--
<i>S. capricornutum</i>	<5.2	--	--	--	--

**Table F-18 Notes:**

1. From the Discharger’s laboratory report no. P-2251.1, dated June 30, 2001. Results as formaldehyde. Divide by 0.37 to obtain equivalent formalin concentration.

Since formalin treatments are usually utilized as a batch of flush treatment which result in discharges from three to eight hours, short term tests were conducted with *C. dubia*, exposing the organisms for 2-hour and 8-hour periods, removing them from the chemical, and continuing the observation period for seven days in clean water. The results were as follows:

**Table F-19. Short-Term Aquatic Toxicity of Formalin<sup>1</sup>**

Species	7-day LC50, mg/L	LOAEL, mg/L	NOAEL, mg/L
<i>C. dubia</i> – 2-hour exposure	73.65	46.3	20.7
<i>C. dubia</i> – 8-hour exposure	13.99	15.3	6.7

**Table F-19 Notes:**

1. From the Discharger’s laboratory report no. P-2251.1, dated June 30, 2001. Results as formaldehyde. Divide by 0.37 to obtain equivalent formalin concentration.

Results of both acute and chronic aquatic life toxicity testing conducted by the Discharger’s Pesticide Unit and the Basin Plan narrative toxicity objective were considered when determining whether WQBELs for formalin as formaldehyde were necessary. Results of seven-day chronic toxicity tests indicated *C. dubia* was the most sensitive species, with a seven-day NOEC value of 1.3 mg/L formaldehyde for survival and less than 1.3 mg/L for reproduction (the Lahontan Water Board used a NOEC of 1.3 mg/L). Acute toxicity tests conducted using *C. dubia* showed a 96- hour NOAEL of 1.3 mg/L formaldehyde. The additional acute toxicity tests with *C. dubia*, conducted using only an eight-hour exposure, resulted in a 96-hour NOAEL concentration of 6.7 mg/L formaldehyde.

The Lahontan Water Board has determined that if formalin is used, formaldehyde may be discharged at levels that cause, have the reasonable potential to cause, or contribute to an excursion of the Basin Plan narrative water quality objective. Accordingly, this Order includes WQBELs for formaldehyde. Although formaldehyde treatments are short in duration, exposure to formaldehyde in the receiving water as a result of discharges from the Facility may be long-term due to

retention time in the settling pond and potential application procedures (e.g., successive raceway treatments, drip treatments for eggs). Therefore, an average monthly effluent limitation (AMEL) of 0.65 mg/L and a maximum daily effluent limitation (MDEL) of 1.3 mg/L are calculated based on the 96-hour NOAEL value and using the procedure in U.S. EPA's March 1991 Technical Support Document for Water Quality-based Toxics Control (EPA/505/2-90-001) (TSD) for calculating WQBELs as described in section 4.3.4. of this Fact Sheet. These effluent limitations have been retained from Order R6V-2017-0025. Use and monitoring of formaldehyde must be reported as specified in the MRP (Attachment E).

4.3.3.4.2.3. **Hydrogen Peroxide.** Hydrogen peroxide (35 percent H<sub>2</sub>O<sub>2</sub>) is used at the Facility for the control of external parasites as a raceway flush treatment at a concentration of 100 mg/L or less, for one hour. The FDA approved hydrogen peroxide to control fungi on fish at all life stages, including eggs. Hydrogen peroxide may also be used to control bacterial gill disease in salmonids, and, through an INAD, external parasites. Hydrogen peroxide is a strong oxidizer that rapidly breaks down into water and oxygen; however, it exhibits toxicity to aquatic life during the oxidation process.

The Lahontan Water Board considered the results of acute aquatic life toxicity testing conducted by the Discharger's Pesticide Unit when determining whether WQBELs for hydrogen peroxide were necessary in this Order. Results of an acute toxicity test using *C. dubia* showed a 96-hour NOAEL of 1.3 mg/L based on continual constant exposure to hydrogen peroxide. When exposed to hydrogen peroxide for two hours followed by a triple lab water flush and normal test completion, *C. dubia* showed a 96-hour NOEC of 2 mg/L.

Effluent hydrogen peroxide data are not available to assess the impact of hydrogen peroxide used at the Facility. Therefore, the following information and calculations were used to estimate the effluent hydrogen peroxide concentrations from flush treatments at Discharge Points 001 and 002. The calculations assume the flow from the raceways mixes completely with the volume of water in the settling basin and is discharged with no further concentration, breakdown, or dilution of hydrogen peroxide.

The hatchery has six raceways, with a total water flow rate through each raceway estimated at 1.83 cfs. Assuming a retention time of 1 hour, the dilution volume of water from one raceway after 1 hour = (1.83 cfs) x (26,930 gallons/hour) x (1 hour) = 49,282 gallons (where 1 cfs = 26,930 gallons/hour). Accordingly, the dilution volume in all 6 raceways = 6 x (119,839 gallons) = 295,691 gallons.

The Facility has two settling ponds, each having a surface area of 18,200 square feet and a depth that tapers from 12 to 16 feet. The volume of each settling pond at 18,200 square feet x 14 feet (average between 12 and 16 feet) is 254,800 cubic feet, or 1,906,036 gallons (where 1 cubic foot = 7.48052 gallons). The volume of both settling ponds is therefore estimated to be 3,812,072 gallons.

The total dilution in the six raceways and two settling ponds = (295,691 gallons) + (3,812,072 gallons) = 4,107,763 gallons.

Flow and volume calculations use the total dilution volume of a 1-hour treatment at 4,107,763 gallons, or 15,549.576 liters (1 gallon = 3.7854118 liters).

Total mass of hydrogen peroxide applied in milligrams = (# raceways treated) x (treatment time in hours) x (raceway flow in cfs) x (26,930 gallons/hour) x (3.7854118 liters/gallon) x (hydrogen peroxide concentration in mg/L). The estimated concentrations, based on the number of raceways treated, are summarized in Table F-17.

**Table F-20. Estimated Effluent Hydrogen Peroxide Concentration**

Number of Raceways Treated with H <sub>2</sub> O <sub>2</sub>	H <sub>2</sub> O <sub>2</sub> Treatment Concentration, mg/L	Treatment Time in Hours	Total Mass of H <sub>2</sub> O <sub>2</sub> Applied, mg	Total Dilution Volume in Liters	Estimated Final Effluent H <sub>2</sub> O <sub>2</sub> , mg/L
1	100	1	6,529,330	15,549,576	0.42
2	100	1	13,058,660	15,549,576	0.84
3	100	1	19,587,990	15,549,576	1.26
4	100	1	26,117,320	15,549,576	1.68
5	100	1	32,646,650	15,549,576	2.10
6	100	1	39,175,980	15,549,576	2.52

The MEC for hydrogen peroxide was non-detect based on one sample collected in June 2018. The Lahontan Water Board has determined, based on the available toxicity testing data and the estimated concentrations, that hydrogen peroxide may be discharged at levels that cause, have reasonable potential to cause, or contribute to an excursion of the Basin Plan narrative water quality objective. Accordingly, this Order includes WQBELs for hydrogen peroxide. The actual effluent concentrations are likely to be lower, as the calculations assume no breakdown of hydrogen peroxide. Because hydrogen peroxide is a strong oxidizer, concentrations are unlikely to persist for long periods, therefore, a MDEL of 1.3 mg/L is calculated based on the 96-hour NOAEL value and using the procedure in U.S. EPA’s TSD for calculating WQBELs as described in section 4.3.4. of this Fact Sheet. This effluent limitation has been retained from Order R6V-2017-0025. Use and monitoring of hydrogen peroxide must be reported, as specified, in the MRP (Attachment E).

4.3.3.4.2.4. **pH.** The Basin Plan includes a water quality objective for pH, which states:

*“In fresh waters with designated beneficial uses of COLD or WARM, changes in ambient pH levels shall not exceed 0.5 pH units. For all other waters of the Region, the pH shall not be depressed below 6.5 nor raised above 8.5. The Regional Board recognizes that some waters of the Region may have natural pH levels outside of the 6.5 to 8.5 range. Compliance with the pH objective for these waters will be determined on a case-by-case basis.”*

Order R6V-2017-0025 contained effluent limitations for pH, requiring the discharge to have a pH of not less than 6.5 standard units nor greater than 8.5 standard

units. The Basin Plan's pH objective is an antidegradation-based objective which requires that there be no change greater than 0.5 standard units in waters designated for the COLD and WARM beneficial uses. Order R6V-2017-0025 also specified that in instances where the ambient pH of the influent exceeds 8.5 standard units, the effluent pH shall not exceed the ambient pH of the influent by more than 0.5 standard units. In the 67 influent measurements collected by the Discharger between July 2017 and December 2022, the pH of the influent groundwater (representative of the upstream receiving water quality) naturally ranged from 6.27 to 8.57 standard units. Based on the Basin Plan objective, this Order retains effluent limitations for pH not to be depressed below 6.5 standard units nor raised above 8.5 standard units.

Additionally, requiring the effluent pH to be substantially less than naturally occurring background levels may result in adverse impacts to local fauna. Therefore, this Order includes effluent limitations for pH based on the site-specific water quality objectives established in the Basin Plan. The case-by-case basis in the Basin Plan is stated as a sampling event by sampling event basis in this Order. In instances where the pH of the influent groundwater exceeds 8.5 standard units, this Order retains specifications from Order R6V-2017-0025 that the pH of the effluent at the discharge point shall not exceed the pH of the groundwater by more than 0.5 standard units.

- 4.3.3.4.2.5. **Settleable Solids.** The Basin Plan includes a water quality objective for surface waters that "*waters shall not contain substances in concentrations that result in deposition of material that causes nuisance or that adversely affects the water for beneficial uses. For natural high quality waters, the concentration of settleable materials shall not be raised by more than 0.1 milliliter per liter.*" Order R6V-2017-0025 contained an effluent limitation for settleable solids of 0.1 ml/L as an AMEL. The Lahontan Water Board has retained the numeric effluent limitation for settleable solids for the Facility in order to prevent an in-stream excursion above the water quality standard.

#### 4.3.4. **WQBEL Calculations**

##### 4.3.4.1. **Pollutants That Did Not Demonstrate Reasonable Potential**

WQBELs are not included in this Order for constituents that do not demonstrate reasonable potential or where it was undetermined whether WQBELs were necessary (e.g., where the reported detection levels are higher than the applicable criteria/objectives). However, monitoring during the term of this Order for those pollutants is required in accordance with section 1.3 of the SIP. If concentrations of these constituents are found to have increased significantly, the Discharger will be required to investigate the sources of the increases. Remedial measures are required if the increases pose a threat to receiving water quality.

##### 4.3.4.2. **Pollutants with Reasonable Potential**

This Order includes WQBELs for fluoride, formaldehyde, hydrogen peroxide, pH, and settleable solids for discharges from Discharge Points 001 and 002. WQBELs for fluoride, formaldehyde, and hydrogen peroxide were calculated based on the water quality objectives and procedures described below. For WQBELs based on Basin Plan

objectives, (i.e., pH and settleable solids), the objectives are applied directly as effluent limitations.

#### 4.3.4.2.1. Fluoride

4.3.4.2.1.1. **SIP Intake Water Credit Requirements.** SIP section 1.4.4 provides for intake water credits under specific circumstances. When met, a discharger may discharge a mass or concentration of a pollutant that is no greater than the mass or concentration found in its intake water (e.g., the discharger may add a mass of the pollutant to its waste stream if it also removes an equal or greater mass prior to discharge, resulting in no net addition of the pollutant). This Order provides intake water credits for fluoride discharges from Discharge Points 001 and 002, which comply with the SIP requirements.

In accordance with section 1.4.4 of the SIP, the Lahontan Water Board may consider pollutants in intake water on a pollutant-by-pollutant and discharge by-discharge basis when establishing WQBELs provided that the Discharger has demonstrated to the satisfaction of the Lahontan Water Board that five specified conditions are met. The Lahontan Water Board finds that the discharges from the Facility meet the conditions, outlined in the SIP, for intake credits for fluoride, as described below.

*Condition 1. The observed maximum ambient background concentration, as determined in section 1.4.3.1 of the SIP, and the intake water concentration of the pollutant exceeds the most stringent applicable criterion/objective for that pollutant.*

The applicable Basin Plan objective from Table 3-21 for fluoride is 0.2 mg/L. Upstream receiving water fluoride concentrations in the Mojave River ranged from 0.16 mg/L to 5.5 mg/L based on 28 samples collected between July 2001 and May 2013. The Mojave River in the vicinity of the discharges from the Facility is listed as impaired for fluoride. Influent fluoride concentrations ranged from 0.27 mg/L to 0.31 mg/L based on 6 samples collected between December 2017 and October 2022. Based on upstream receiving water and influent data, this condition is satisfied because the observed maximum intake water concentration for fluoride exceeds the most stringent water quality criterion/objective.

*Condition 2. The intake water credits provided are consistent with any TMDL applicable to the discharge that has been approved by the Regional Water Board, State Water Board, and U.S. EPA.*

Although the Mojave River is listed on the CWA Section 303(d) List of Water Quality Limited Segments requiring TMDLs for fluoride (which is known to originate from natural sources), the proposed TMDL is not scheduled for completion until 2031. Therefore, this condition is satisfied because there are currently no TMDLs applicable to the discharge.

*Condition 3. The intake water is from the same water body as the receiving water body. The discharger may demonstrate this condition by showing that: a) the ambient background concentration of the pollutant in the receiving water, excluding any amount of the pollutant in the facility's discharge, is similar to that of the intake water; b) there is a direct hydrological connection between the intake and discharge*

*points; c) the water quality characteristics are similar in the intake and receiving waters; and d) the intake water pollutant would have reached the vicinity of the discharge point in the receiving water within a reasonable period of time and with the same effect had it not been diverted by the discharger.*

The Mojave River Fish Hatchery overlies the Upper Mojave Valley Groundwater Basin as identified in Department of Water Resources (DWR) Bulletin 118. The Upper Mojave Valley Groundwater Basin is composed of two aquifers: the shallow “floodplain” aquifer, and the deeper “regional” aquifer. The intake water is from wells screened through both the floodplain and the deeper regional aquifer. The floodplain aquifer is generally composed of river channel deposits and flood plain deposits and follows the course of the Mojave River. The regional aquifer is composed of unconsolidated (generally) alluvium, lake, and playa deposits and is aerially more extensive. The floodplain aquifer is more permeable and the primary water supply source for the basin. The two aquifers are unconfined and hydraulically connected. Both the floodplain and the regional aquifers directly contribute to base flow of the Mojave River and are recharged by the Mojave River. The floodplain aquifer is in direct communication with the river wherever the aquifer is present. The regional aquifer is in direct contact with the river where subsurface features create a condition where the river and the deeper aquifer are in direct communication. During high flow periods the river is a “losing stream” and replenishes the groundwater aquifer. During low flow periods, the river is a “gaining stream” and is fed by the underlying aquifers. Consequently, the intake water would have reached the receiving water without the effluent discharge to the Mojave River. [Lines, Gregory C., 1996 Ground-water and Surface-water Relations along the Mojave River, Southern California: U.S. Geological Survey Water-Resources Investigations Report 95-4189]

Additionally, “The hydraulic connection between aquifers is supported by chemical and isotopic data which indicate that in areas near the river, the regional aquifer contains water that was recharged by the Mojave River less than 50 years ago (Izbicki and others, 1995).” In the area of the Facility, “...ground-water flowed from the regional aquifer to the floodplain aquifer during predevelopment conditions and from the floodplain aquifer to the regional aquifer (a reversal in flow direction) during the adjudication period of 1931-90.” [USGS Fact Sheet 122-01, “Water Supply in the Mojave River Ground-Water Basin, 1931-99, and the Benefits of Artificial Recharge”, November 2001]. The Figures “2” and “3”, below, from the referenced USGS Fact Sheet illustrates the interconnectivity of the floodplain and regional aquifers of the Mojave River.

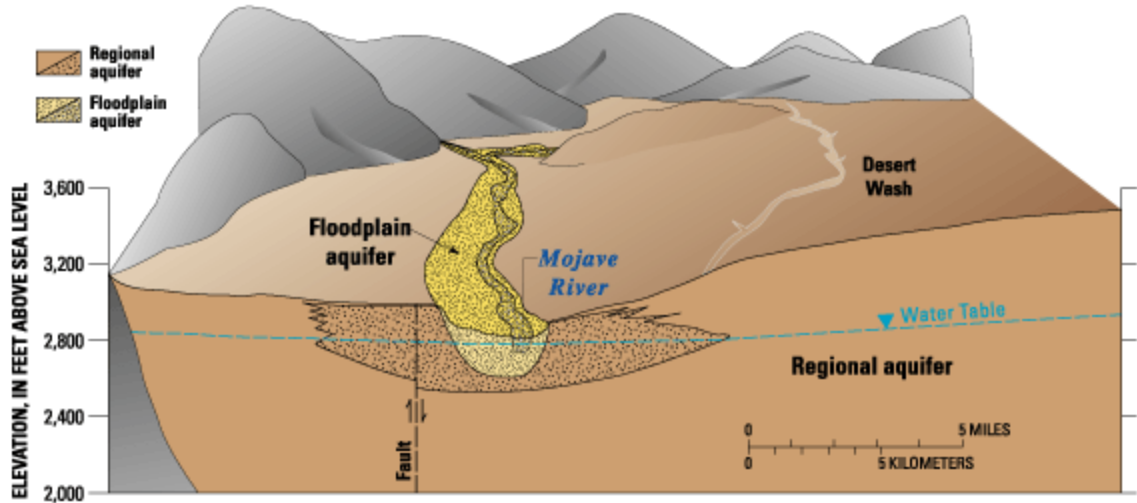

Figure 2. Conceptualized geologic section of the aquifer system. View is to the south in the Alto subarea.

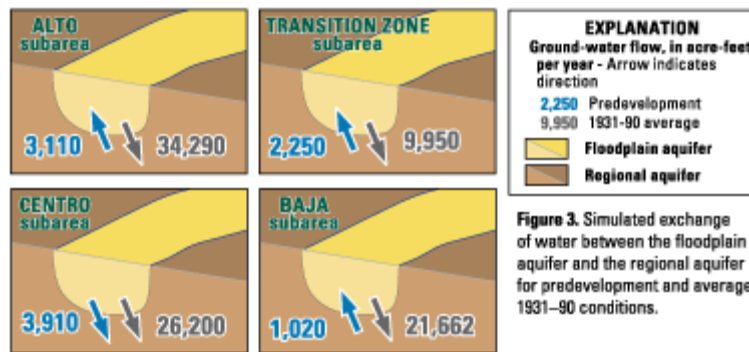

Figure 3. Simulated exchange of water between the floodplain aquifer and the regional aquifer for predevelopment and average 1931-90 conditions.

This condition is satisfied because there is a direct hydrological connection between the groundwater (intake water source) and the receiving water (the Mojave River), and because the intake water fluoride would have reached the vicinity of the discharge point in the receiving water had it not been diverted by the Discharger.

*Condition 4. The facility does not alter the intake water pollutant chemically or physically in a manner that adversely affects water quality and beneficial uses.*

The Facility does not alter the fish hatchery wastewater (i.e., groundwater) that is eventually discharged at Discharge Points 001 and 002 with respect to fluoride by the addition of chemicals or other pollutants, and the pumping and discharge of groundwater from the aquifers causes no resulting environmental degradation. Accordingly, this condition is satisfied, because the Facility does not alter the intake water in a manner that adversely impacts water quality and beneficial uses.

*Condition 5. The timing and location of the discharge does not cause adverse effects on water quality and beneficial uses that would not occur if the intake water pollutant had been left in the receiving water body.*

The timing and location of the discharge from the Facility does not cause adverse effects on water quality and beneficial uses that would not occur if the pollutants in the intake water had been left in the intake water body. As shown in Table F-21, fluoride concentrations are generally lower in the influent and effluent than the



upstream receiving water. Additionally, receiving water fluoride concentrations downstream of the Facility are generally lower than upstream concentrations.

**Table F-21. Summary of Fluoride Monitoring Data**

Monitoring Location	Minimum, mg/L	Maximum, mg/L	Average, mg/L	Number of Data Points
Influent (Monitoring Location INF-001)	0.21	0.38	0.29	31
Effluent (Monitoring Location M-001)	0.24	0.37	0.30	21
Upstream Receiving Water (Mojave River below Forks Reservoir)	0.16	5.5	1.8	28
Downstream Receiving Water (Mojave River at the Upper Narrows)	0.15	1.95	0.43	29

Therefore, the Lahontan Water Board will allow intake water credits for fluoride. This credit is to offset elevated levels of fluoride found in the intake water. As stated in section 1.4.4 of the SIP, the Lahontan Water Board *"may establish effluent limitations allowing the facility to discharge a mass and concentration of the intake water pollutant that is no greater than the mass and concentration in the facility's intake water ... so there is no net addition of the pollutant in the discharge compared to the intake water."*

4.3.4.2.1.2. **Calculation of Intake Water Credits.** To qualify for an intake water credit, the effluent pollutant concentration must be less than or equal to the intake pollutant concentration. However, intake and effluent data collected on the same day may differ due to factors unrelated to Facility operations, such as sampling and laboratory analytical variability. Since the residence time of groundwater from intake to discharge is of relatively short duration, samples taken on the same day should be representative of the same water (assuming the samples are collected within a reasonably short time from each other). As shown in the Table F-22, variability between the influent and effluent occurred throughout the terms of Orders R6V-2011-0081 and R6V-2017-0025; there were times when the effluent concentrations were slightly higher than the influent concentrations, as well as instances when the influent concentrations were higher than the effluent concentrations.

**Table F-22. Influent and Effluent Fluoride Monitoring Data Between November 2011 and October 2022.**

Sample Date	Influent Concentration, mg/L	Effluent Concentration, mg/L
November 17, 2011	0.38	0.37
November 17, 2011	0.37	--
February 7, 2012	0.29	0.30
May 15, 2012	0.38	0.37
May 15, 2012	0.34	0.33
September 5, 2012	0.34	0.37
November 15, 2012	0.31	--
February 19, 2013	0.30	0.30

Sample Date	Influent Concentration, mg/L	Effluent Concentration, mg/L
May 8, 2013	0.30	0.30
August 12, 2013	0.30	0.29
November 19, 2013	0.30	--
February 13, 2014	0.32	--
May 7, 2014	0.30	0.30
August 26, 2014	0.30	0.32
November 25, 2014	0.26	0.27
February 27, 2015	0.24	0.26
May 5, 2015	0.24	0.24
August 28, 2015	0.21	--
November 6, 2015	0.21	--
February 18, 2016	0.27	--
May 27, 2016	0.29	0.26
August 25, 2016	0.29	--
November 16, 2016	0.28	--
February 24, 2017	0.26	--
June 20, 2017	0.27	0.27
December 1, 2017	0.31	0.30
May 8, 2018	0.27	0.27
May 16, 2019	0.27	0.26
May 27, 2020	0.30	0.30
February 2, 2022	0.27	0.27
October 3, 2022	0.28	0.28

To account for the variability among the influent and effluent samples collected by the Discharger, the methodology for developing effluent limitations was revised. Since the residence time of groundwater from intake to discharge is of relatively short duration and the Discharger does significantly alter the waste stream with respect to fluoride, the Lahontan Water Board has assumed the influent and effluent pollutant concentration are drawn from the same distribution. Thus, the 99<sup>th</sup> percentile concentration of the available data from both the influent and effluent monitoring locations was calculated. The resulting 99<sup>th</sup> percentile value represents the upper range of the variability between intake and effluent pollutant concentrations due to sampling and analysis variability. When used as the basis for the effluent limitation, it results in an intake credit that captures the variability between influent and effluent data and prevents the discharge of additional pollutant mass. The 99<sup>th</sup> percentile effluent limit also implies that one percent of the time a value could occur that will exceed the 99<sup>th</sup> percentile, but a higher percentile might include extreme and possibly false values, which might mask a legitimate violation; a lower percentile might result in violations due to sample variability instead of the addition of pollutants. All available influent and effluent data collected at the Facility between 2011 and 2022 was considered in determining the 99<sup>th</sup> percentile effluent limits.

Consistent with SIP section 1.4.4, which requires the Facility to discharge a mass and concentration of the intake water pollutant that is no greater than the mass and concentration found in the Facility’s intake water, where the 99<sup>th</sup> percentile value for a pollutant exceeds the maximum observed influent concentration, the maximum observed influent concentration is established as the effluent limitation. Table F-23 compares the 99<sup>th</sup> percentile value, the maximum observed influent concentration, and the existing MDEL from Order R6V-2017-0025 for fluoride.

**Table F-23. Final Effluent Limitation for Fluoride at Discharge Points 001 and 002**

99th Percentile Value, mg/L	Maximum Observed Influent Concentration, mg/L	Maximum Daily Effluent Limitation, mg/L
0.40	0.38 <sup>1</sup>	0.44

**Table F-23 Notes:**

1. Effluent Limit = Maximum Observed Influent Concentration.

The calculated 99<sup>th</sup> percentile value of 0.40 mg/L is higher than the maximum observed influent concentration of 0.38 mg/L. Additionally, the existing MDEL of 0.44 mg/L is less stringent than both the calculated 99<sup>th</sup> percentile and the maximum observed influent concentration. Accordingly, a daily maximum effluent limit consistent with the maximum observed influent concentration of 0.44 mg/L has been retained in this Order.

**4.3.4.2.2. Formaldehyde**

Effluent limitations for formaldehyde were calculated based on the 96-hour NOAEL value for *C. dubia* (1.3 mg/L) using the procedure in U.S. EPA’s TSD assuming the following:

- No in-stream dilution allowance
- Coefficient of variation (CV) = 0.6 for the lognormal distribution of pollutant concentrations in effluent

*Calculation of Aquatic Life AMEL and MDEL:*

Effluent Characterization Allowance (ECA) based on NOAEL (acute toxicity) for *C. dubia*, with no dilution allowance:

$ECA_{acute} = 1.3 \text{ mg/L}$

$ECA_{chronic} = 1.3 \text{ mg/L}$

*Long-Term Average concentration based on acute ECA:*

$LTA_{acute} = 1.3 \text{ mg/L} \times 0.321 = 0.417 \text{ mg/L}$  (where 0.321 = acute ECA multiplier at 99 percent occurrence probability and 99 percent confidence)

*Long-Term Average concentration based on chronic ECA:*

$LTA_{chronic} = 1.3 \text{ mg/L} \times 0.527 = 0.685 \text{ mg/L}$  (where 0.527 = chronic ECA multiplier at 99 percent occurrence probability and 99 percent confidence)

*Most Limiting LTA concentration based on acute LTA:*

$LTA = 0.417 \text{ mg/L}$

*Average Monthly Effluent Limitation:*

$AMEL = LTA \times 1.55$  (where 1.55 = AMEL multiplier at 95 percent occurrence probability, 99 percent confidence, and  $n = 4$ )

$AMEL_{\text{aquatic life}} = 0.417 \text{ mg/L} \times 1.55 = 0.65 \text{ mg/L}$

*Maximum Daily Effluent Limitation:*

$MDEL = LTA \times 3.11$  (where 3.11 = MDEL multiplier at 99 percent occurrence probability and 99 percent confidence)

$MDEL_{\text{aquatic life}} = 0.417 \text{ mg/L} \times 3.11 = 1.3 \text{ mg/L}$

*Calculation of Human Health AMEL and MDEL:*

This section is not applicable as the formaldehyde limits are based on aquatic life criteria.

*Determination of Final WQBELs:*

The lower AMEL and MDEL based on aquatic life and human health is selected as the WQBEL.

<b>AMEL<sub>aquatic life</sub></b>	<b>MDEL<sub>aquatic life</sub></b>	<b>AMEL<sub>human health</sub></b>	<b>MDEL<sub>human health</sub></b>
0.65 mg/L	1.3 mg/L	Not Applicable	Not Applicable

The final AMEL of 0.65 mg/L and MDEL of 1.3 mg/L for formaldehyde are based on limitations protective of aquatic life.

**4.3.4.2.3. Hydrogen Peroxide**

As hydrogen peroxide is a strong oxidizer, effluent concentrations are unlikely to persist for long periods. Therefore, only a MDEL was calculated based on the 96-hour NOAEL value for *C. dubia* and using the procedure in U.S. EPA's TSD assuming the following:

- No in-stream dilution allowance.
- CV = 0.6 for the lognormal distribution of pollutant concentrations in effluent.

Effluent Concentration Allowances based on NOAEL with no dilution allowance:

$ECA_{\text{acute}} = 1.3 \text{ mg/L}$

No chronic toxicity data, Long-Term Average concentration based on acute ECA:

$LTA = 1.3 \text{ mg/L} \times 0.321 = 0.4173 \text{ mg/L}$  (where 0.321 = acute ECA multiplier at 99 percent occurrence probability and 99 percent confidence)

*Maximum Daily Effluent Limitation:*

$MDEL = LTA \times 3.11$  (where 3.11 = MDEL multiplier at 99 percent occurrence probability and 99 percent confidence)

$$\text{MDEL} = 0.4173 \text{ mg/L} \times 3.11 = 1.3 \text{ mg/L}$$

This effluent limitation has been established for protection of aquatic life against toxic effects from exposure to hydrogen peroxide in the discharge.

#### 4.3.5. Whole Effluent Toxicity (WET)

##### Numeric Water Quality Objectives

State Policy for Water Quality Control: Toxicity Provisions (Toxicity Provisions) established numeric aquatic toxicity water quality objectives to protect Aquatic Life beneficial uses and a program of implementation. The Regional Board must include the requirements specified in the Toxicity Provisions for NPDES permits issued, reissued, renewed, or reopened after the effective dates of the Toxicity Provisions for Non-Stormwater NPDES Dischargers. The Regional Board is authorized to exempt certain Non-Stormwater NPDES Dischargers from some or all of Section III.C of the Toxicity Provisions if the Regional Board makes a finding that the discharge will have no reasonable potential to cause or contribute to an exceedance of the numeric aquatic toxicity water quality objectives. The reasonable potential conclusion necessary to exempt insignificant discharges need not be based on the reasonable potential analysis methods set forth in Section III.C.3 of the Toxicity Provisions.

The authorized discharge from the Facility is an insignificant discharge. The quality of effluent supports the propagation and growth of fish within the hatchery. The facility is inherently a large-scale biological indicator of the health of the water leaving the fish hatchery. In some historical instances, high mortality rates of fish were caused by an infectious disease or parasite, not from a chemical water quality issue. There is a specific acute toxicity test for rainbow trout which is one of the fish species raised at the facility. The facility produces large quantities of fish, beginning with eggs and raising them until they are 2–6 months of age. If there were any signs of acute toxicity, then there would be an investigation into the cause by fishery biologist. To date, the only signs of significant die off have been associated with infectious diseases or parasites and the hatchery has been shut down and sterilized before there is wide spread infection. The infectious diseases and/or parasites are not the result of water quality, but a growth that may rapidly occur with a dense population in a limited area.

Likewise, the hatchery observes its fish population for chronic effects (e.g. death and slower growth rate) prior to releasing the raised trout. If the fish production decreases an investigation would be done by fishery biologist to evaluate the cause. No investigation has been reported about reduced fish growth rates or death at the Facility.

Based on the features of the Facility and the nature of the discharge, the discharge does not exhibit any signs of reasonable potential to cause an exceedance of the numeric water quality objectives. Thus, the Regional Board authorizes the exemption of the discharger from all of the requirements in Section III.C.1- Section III.C.10 of the Toxicity Provisions.

##### Narrative Objective

The Basin Plan specifies a narrative objective for toxicity, requiring that *“All waters shall be maintained free of toxic substances in concentrations that are toxic to, or that produce detrimental physiological responses in human, plant, animal, or aquatic life.”*

Compliance with this objective may be determined by use of indicator organisms, analyses of species diversity, population density, growth anomalies, bioassays of appropriate duration and/or other appropriate methods as specified by the Lahontan Water Board. (Bioassays, or biotoxicity testing, involves measuring the toxic effects of an effluent on specified organisms according to nationally approved protocols.) The survival of aquatic life in surface waters subjected to a waste discharge, or other controllable water quality factors, shall not be less than that for the same water body in areas unaffected by the waste discharge, or when necessary, for other control water that is consistent with the requirements for “experimental water” as defined in *Standard Methods for the Examination of Water and Wastewater* (American Public Health Association, et al. 1992).

The Facility effluent is pumped groundwater used in raising fish. The fish are actively monitored for health and if the fish appear to be stressed or many fish start to die, then fishery biologists investigate the cause and prescribe aquaculture drugs. No regular aquaculture drug or chemicals are applied to the system to raise the freshwater trout, except for treatment for a variety of sicknesses. The drugs or chemicals are only used for a limited duration, have limits on the frequency of treatment, and typically only used one at any given time to eliminate potential compounded effect of a mixture. For drugs and chemicals with known aquatic impacts, sampling and effluent limits for those drugs are established in this permit (see Table 2 Final Effluent Limits). The effluent from the fish hatchery has no reasonable potential to exceed the narrative objective for toxicity.

#### **4.4. Final Effluent Limitation Considerations**

##### **4.4.1. Mass-based Effluent Limitations**

40 C.F.R. section 122.45(f)(1) requires effluent limitations be expressed in terms of mass, with some exceptions, and 40 C.F.R. section 122.45(f)(2) allows pollutants that are limited in terms of mass to additionally be limited in terms of other units of measurement. This Order includes effluent limitations expressed in terms of concentration, as mass limitations are not necessary to protect the beneficial uses of the receiving water.

##### **4.4.1. Anti-Backsliding Requirements**

Sections 402(o) and 303(d)(4) of the CWA and federal regulations at 40 C.F.R. section 122.44(l) prohibit backsliding in NPDES permits. These anti-backsliding provisions require effluent limitations in a reissued permit to be as stringent as those in the previous permit, with some exceptions where limitations may be relaxed. The effluent limitations in this Order are at least as stringent as the effluent limitations in the previous Order.

##### **4.4.2. Antidegradation Policies**

Section 131.12 of 40 C.F.R. requires that the state water quality standards include an antidegradation policy consistent with the federal policy. The State Water Board established California’s antidegradation policy in State Water Board Resolution 68-16. Resolution 68-16 incorporates the federal antidegradation policy where the federal policy applies under federal law. Resolution 68-16 requires that existing water quality be maintained unless degradation is justified based on specific findings. The Lahontan

Water Board's Basin Plan implements, and incorporates by reference, both the state and federal antidegradation policies.

This Order does not provide for an increase in the permitted design flow or allow for an increase in mass or concentration of any pollutant. Therefore, the issuance of this permit is consistent with the State's antidegradation policy.

#### **4.4.3. Stringency of Requirements for Individual Pollutants**

This Order contains both technology-based effluent limitations and WQBELs for individual pollutants. The technology-based effluent limitations consist of restrictions on TSS. Technology-based restrictions are discussed in section 4.2 of the Fact Sheet. This Order's technology-based pollutant restrictions implement the minimum, applicable federal technology-based requirements.

This Order includes WQBELs for fluoride, formaldehyde, hydrogen peroxide, pH, and settleable solids at Discharge Points 001 and 002. WQBELs have been scientifically derived to implement water quality objectives that protect beneficial uses. Both the beneficial uses and the water quality objectives have been approved pursuant to federal law and are the applicable federal water quality standards. The scientific procedures for calculating the WQBELs are based on the SIP, which was approved by U.S. EPA on May 18, 2000. All beneficial uses and water quality objectives contained in the Basin Plan were approved under state law and submitted to and approved by U.S. EPA prior to May 30, 2000. Collectively, this Order's restrictions on individual pollutants are no more stringent than required to implement the requirements of the CWA.

#### **4.5. Interim Effluent Limitations – Not Applicable**

#### **4.6. Land Discharge Specifications – Not Applicable**

#### **4.7. Recycling Specifications - Not Applicable**

### **5. RATIONALE FOR RECEIVING WATER LIMITATIONS**

The receiving water limitations in this Order are based upon the water quality objectives contained in the Basin Plan and State Board Plans and Policies.

#### **5.1. Surface Water**

The Mojave River Fish Hatchery pumps groundwater from the regional aquifer, uses it for hatchery operations, and discharges it to surface water that is contiguous with the local flood plain aquifer of the Mojave River. The discharge includes constituents contained in groundwater that were concentrated by evaporation, and wastes from fish hatchery operations. During storm events, constituents in storm water may also be present in the discharge. The Discharger is responsible for constituents contributed by groundwater pumping, hatchery operations and hatchery property management.

The Basin Plan contains numeric and narrative water quality objectives applicable to all surface waters within the Lahontan Region. Water quality objectives include an objective to maintain the high quality waters pursuant to federal regulations (part 131.12) and State Water Board Resolution No. 68-16. Surface water limitations in this Order are included to ensure protection of beneficial uses of the receiving waters (see section 5 of this Order).

Additionally, Part 3 of the Water Quality Control Plan for Inland Surface Waters, Enclosed Bays, and Estuaries of California – Bacteria Provisions and a Water Quality Standards Variance Policy (Statewide Bacteria Provisions) contains numeric water quality objectives for bacteria in waters with the Water Contact Recreation (REC-1) beneficial use. Receiving water limitations in this Order are included to ensure protection of beneficial uses of the receiving water.

Consistent with the Toxicity Provisions, the Regional Board has included the water quality objectives in Section II.C of the Toxicity Provisions as receiving water limitations in the NPDES permit.

Consistent with the Toxicity Provisions, the Regional Board may rely solely on the numeric aquatic toxicity water quality in Section II.C to address non-chemical specific aquatic toxicity unless there is information to suggest that the numeric aquatic toxicity water quality objective would not protect all aquatic species in the relevant water body. There is no information to suggest that the numeric aquatic toxicity water quality objectives would not protect all aquatic species in the relevant water body. Therefore, aquatic toxicity receiving water limitations derived from the narrative toxicity water quality objective are not included in the permit.

The narrative objective for chemical constituents in the Basin Plan states that “Waters shall not contain concentrations of chemicals that adversely affect the water beneficial uses.” The receiving waters collectively have the following beneficial uses: Municipal and Domestic Supply (MUN); Agricultural Supply (AGR); Groundwater Recharge (GWR); Water Contact Recreation (REC-1); Noncontact Water Recreation (REC-2); Commercial and Sport fishing (COMM); Warm Freshwater Habitat (WARM); Cold Freshwater Habitat (COLD); Wildlife Habitat (WILD); Rare, Threatened, or Endangered Species (RARE); Migration of Aquatic Organisms (MIGR); Water Quality Enhancement (WQE); and Flood Peak Attenuation/Flood Water Storage (FLD).

The channel and wetlands to which the Facility discharges at Discharge Point 001 are effluent dominated. The golf course ponds, Spring Valley Lake, Horseshoe Lake, and Pelican Lake consist of effluent mixed with water from additional sources. Thus, no physical upstream receiving water monitoring locations exist outside the influence of the discharges from Discharge Points 001 and 002. Therefore, consistent with Order R6V-2011-0081, compliance with numeric receiving water limitations shall be measured at Monitoring Location EFF-001.

## **5.2. Groundwater**

The Basin Plan contains numeric and narrative water quality objectives applicable to all groundwaters within the Lahontan Region. Groundwater quality objectives include an objective to maintain the high quality waters pursuant to State Water Board Resolution No. 68-16. The Upper Mojave River Valley Groundwater Basin has the following beneficial uses: Municipal and Domestic Supply (MUN); Agricultural Supply (AGR); Industrial Service Supply (IND); Freshwater Replenishment (FRSH); and Aquaculture (AQUA).

Beneficial uses designated to the Mojave River apply to the subsurface flow beneath the Mojave River Flood Plain. These subsurface flows may not be visible in many sections of the Mojave River during the dry season, yet they are both present and contiguous with



intermittent sections of the river that contain perennial surface flows. Qualitative and numeric limitations for the Mojave River apply to these subsurface flows. Since the surface and subsurface flows in the Mojave River are connected, impacts to groundwater under the river channel are monitored with samples collected from surface water shortly prior to infiltration to the subsurface.

## 6. RATIONALE FOR PROVISIONS

### 6.1. Standard Provisions

Standard Provisions, which apply to all NPDES permits in accordance with 40 C.F.R. section 122.41, and additional conditions applicable to specified categories of permits in accordance with 40 C.F.R. section 122.42, are provided in Attachment D. The Discharger must comply with all standard provisions and with those additional conditions that are applicable under section 122.42.

Sections 122.41(a)(1) and (b) through (n) of 40 C.F.R. establish conditions that apply to all state-issued NPDES permits. These conditions must be incorporated into the permits either expressly or by reference. If incorporated by reference, a specific citation to the regulations must be included in the Order. Section 123.25(a)(12) of 40 C.F.R. allows the state to omit or modify conditions to impose more stringent requirements. In accordance with 40 C.F.R. section 123.25, this Order omits federal conditions that address enforcement authority specified in 40 C.F.R. sections 122.41(j)(5) and (k)(2) because the enforcement authority under the Water Code is more stringent. In lieu of these conditions, this Order incorporates by reference Water Code section 13387(e).

### 6.2. Special Provisions

#### 6.2.1. Reopener Provisions

These provisions are based on 40 C.F.R. section 122.62 and allow modification of this Order and its effluent limitations as necessary in response to updated water quality objectives, regulations, or other new relevant information that may be established in the future and other circumstances as allowed by law.

#### 6.2.2. Special Studies and Additional Monitoring Requirements

**6.2.2.1. Chemical and Aquaculture Drug Use.** Prior to using any new chemical or aquaculture drug at the Facility, the Discharger is required to submit to the Lahontan Water Board supplemental information (e.g., name, purpose, amount to be used) and toxicity testing data for the new chemical or aquaculture drug as specified in Section VI.C.2.a of this Order. These reporting and toxicity testing requirements are needed for the Lahontan Water Board to determine if the discharge of a new drug or chemical by the Facility has reasonable potential to cause, or contribute to an in-stream excursion above any chemical-specific water quality criteria, narrative water quality objective for chemical constituents from the Basin Plan, or narrative water quality objective for toxicity from the Basin Plan.

**6.2.2.2. Reporting of Unanticipated Discharges.** Consistent with Order R6V-2017-0025, this Order requires the Discharger to provide an oral report within 24 hours and a written report within 7 days of: (1) discovery of the failure in, or damage to, the settling pond or

an aquatic animal containment system resulting in an unanticipated material discharge of pollutants to waters of the United States or State; and (2) a spill of drugs, chemicals, pesticides, or feed that results in a discharge to waters of the United States or State.

### 6.2.3. **Best Management Practices and Pollution Prevention**

6.2.3.1. **Best Management Practices (BMP) Plan – Aquaculture Operations.** BMP plan requirements are established based on requirements in the ELGs for the Concentrated Aquatic Animal Production Point Source Category at 40 C.F.R. part 451. CAAP facilities that are subject to the federal ELGs are required to develop and maintain a BMP plan that addresses the following requirements: solids control, material storage, structural maintenance, recordkeeping, and training. The Discharger must make the BMP plan available to the Lahontan Water Board upon request and submit certification that the BMP plan has been developed.

6.2.3.2. **Storm Water Pollution Prevention Plan (SWPPP).** This Order requires the Discharger to develop and implement a SWPPP, in accordance with Attachment I to the Order that describes site-specific BMPs for minimizing contamination of storm water runoff and for preventing contaminated storm water runoff from being discharged directly to waters of the State. Storm water runoff at the Facility has the potential to come in contact with pollutants associated with aquaculture activities such as chemicals, fuel, waste oil, vehicle wash water, and other storage of other materials.

### 6.2.4. **Construction, Operation, and Maintenance Specifications**

6.2.4.1. Solid waste disposal provisions in this Order are based on the requirements of CCR Title 27 and prevention of unauthorized discharge of solid wastes into waters of the United States or waters of the State. Other construction, operation, and maintenance specifications are required to prevent other unauthorized discharges to waters of the United States or waters of the State.

6.2.4.2. This Order authorizes the Discharger to discharge up to 1,000 gallons of recirculated water from the recirculated water aeration tower to the adjacent drainage ditch no more than once every 12 months. The drainage ditch is not considered a water of the United States or the State. In order to limit the discharge of pollutants in storm water and minimize erosion in the drainage ditch, this Order requires the Discharger to ensure discharges from the aeration tower occurs during dry weather conditions in a manner that ensures percolation of the planned discharges within 100 feet and minimizes erosion within the drainage channel.

6.2.5. **Special Provisions for Publicly-Owned Treatment Works (POTWs) – Not Applicable**

6.2.6. **Other Special Provisions – Not Applicable**

6.2.7. **Compliance Schedules – Not Applicable**

## 7. RATIONALE FOR MONITORING AND REPORTING REQUIREMENTS

CWA section 308 and 40 C.F.R. sections 122.41(h), (j)-(l), 122.44(i), and 122.48 require that all NPDES permits specify monitoring and reporting requirements. Water Code sections 13267 and 13383 also authorize the Lahontan Water Board to establish

monitoring, inspection, entry, reporting, and recordkeeping requirements. The Monitoring and Reporting Program (MRP), Attachment E of this Order establishes monitoring, reporting, and recordkeeping requirements that implement federal and state requirements. The following provides the rationale for the monitoring and reporting requirements contained in the MRP for this facility.

## **7.1. Influent Monitoring**

### **7.1.1. Monitoring Location INF-001**

- 7.1.1.1. Influent monitoring frequencies and sample types for electrical conductivity, pH, and temperature have been retained from Order No. R6V-2017-0025 to assess the levels of pollutants in the extracted groundwater for these parameters. In addition, the influent monitoring frequencies and sample type for flow, pH, and temperature have been retained from Order No. R6V-2017-0025 to assess the quality of the influent for these parameters.
- 7.1.1.2. Monitoring data collected over the term of Order No. R6V-2017-0025 for boron, chloride, nitrate, sulfate, and total dissolved solids did not demonstrate reasonable potential to exceed water quality objectives/criteria. The monitoring frequency for boron, chloride, and sulfate has been revised from annually to once per permit term, however the monitoring frequency for nitrate and total dissolved solids has been retained from Order No. R6V-2017-0025.

## **7.2. Effluent Monitoring**

Pursuant to the requirements of 40 C.F.R. section 122.44(i)(2), effluent monitoring is required for all constituents with effluent limitations. Effluent monitoring is necessary to assess compliance with effluent limitations, and to assess the impacts of the discharge on the receiving stream and groundwater.

### **7.2.1. Monitoring Location EFF-001**

- 7.2.1.1. Effluent monitoring frequencies and sample type for fluoride, formaldehyde, hydrogen peroxide, pH, potassium permanganate, settleable solids, and TSS have been retained from Order No. R6V-2017-0025 to determine compliance with effluent limitations for these parameters.
- 7.2.1.2. The effluent monitoring frequencies and sample type for flow, chloramine-T, dissolved oxygen, electrical conductivity, hardness, PVP Iodine, and temperature have been retained from Order No. R6V-2017-0025 to assess the quality of the effluent for these pollutants.
- 7.2.1.3. Monitoring data collected over the previous permit term for chloride, boron, nitrate, sulfate, total dissolved solids did not demonstrate reasonable potential to exceed water quality objectives/criteria. The monitoring frequency for the remaining pollutants, other than nitrate, has been revised from annually to once per permit term.
- 7.2.1.4. Monitoring data collected over the previous permit term for manganese indicates that the discharges from the Facility does not exhibit reasonable potential to cause or contribute to an exceedance of the applicable water quality objectives, and effluent

limitations have been retained in this Order. This Order retains monthly effluent monitoring for manganese to determine compliance with the applicable effluent limitations. Total recoverable manganese is required for potassium permanganate analyses and calculations, and total hardness is necessary to determine the solubility of manganese. Therefore, monitoring for total recoverable manganese and for hardness is required on a monthly basis only when potassium permanganate is used. This will also help to establish a correlation between potassium permanganate use with total recoverable manganese and hardness effluent concentrations.

### **7.2.2. Monitoring Location EFF-002**

7.2.2.1. Consistent with Order No. R6V-2017-0025, this Order requires flow monitoring at Monitoring Locations EFF-002 to determine the flow at Discharge Points 001 and 002.

7.2.2.2. **Total Phosphorous:** Effluent monitoring for total phosphorous has been added to this Order. Monitoring for this constituent has been added due to the concern of downstream entities and their water quality and the current lack of nutrient data from the hatchery. Monitoring has been set at a frequency of once per quarter to get a basis for nutrients within hatchery effluent.

### **7.2.3. Monitoring Location EFF-003**

7.2.3.1. Consistent with Order No. R6V-2017-0025, this Order requires flow monitoring at Monitoring Location EFF-003 to determine the flow at Discharge Points 001 and 002. Effluent flow at Monitoring Location EFF-003 shall be determined by subtracting the flow measured at Monitoring Location EFF-002 from the total combined flow measured at Monitoring Location EFF-001.

## **7.3. Whole Effluent Toxicity Testing Requirements – Not Applicable**

## **7.4. Receiving Water Monitoring**

The channel and wetlands to which the Facility discharges at Discharge Point 001 are effluent dominated. The golf course ponds, Spring Valley Lake, Horseshoe Lake, and Pelican Lake consist of effluent mixed with water from additional sources. Thus, no physical upstream receiving water monitoring locations exist outside the influence of the discharges from Discharge Points 001 and 002. Therefore, consistent with Order No. R6V-2017-0025, this Order does not require receiving water monitoring. Compliance with numeric receiving water limitations shall be measured at Monitoring Location EFF-001.

### **7.4.1. Surface Water – Not Applicable**

### **7.4.2. Groundwater – Not Applicable**

## **7.5. Other Monitoring Requirements**

### **7.5.1. Quarterly Drug and Chemical Use Report**

Quarterly reporting of drug and chemical use is required in this Order. The ELGs at 40 C.F.R. part 451 require reporting on the use of drugs, disinfectants, and other chemicals in discharges authorized by NPDES permits. To verify that aquaculture drugs and

chemicals are applied at levels that will not cause or contribute to an exceedance of water quality objectives, this Order requires the Discharger to calculate and report the estimated effluent concentrations of drugs and chemicals applied directly to water. Reporting of the estimated effluent concentration is required whenever the drug or chemical is used, even if an effluent sample has been collected.

#### **7.5.2. Feeding and Production Reporting**

This Order requires annual reporting of monthly food usage and annual production of aquatic animals.

#### **7.5.3. Priority Pollutant Metal Monitoring**

Potential discharge of priority pollutants is based on the probability of the pollutants being present in the natural springs and from data collected from CAAP facilities. Data compiled from CAAP facilities, local drinking water wells and the State Water Board's Groundwater Ambient Monitoring Association (GAMA) database were used to determine the potential for metals and other priority pollutants to occur. Accordingly, the Lahontan Water Board requires sampling and analysis of the influent (Monitoring Location INF-001) and effluent (Monitoring Location EFF-001) for priority pollutants listed in Attachment J at least once per permit cycle. The samples shall be analyzed for priority pollutants in the year **2027** and reported to the Water Board no later than **February 1, 2028** (refer to Attachment J for the specific monitoring requirements). In order to ensure that the priority pollutant metal monitoring meet the specifications of this Order, this Order requires the Discharger to submit a Priority Pollutant Metal Monitoring Plan that outlines reporting levels (RLs), method detection limits (MDLs), and analytical methods. The Priority Pollutant Metal Monitoring Plan shall also identify the contract laboratory or laboratories selected to conduct the monitoring and demonstrate that they are Environmental Laboratory Accreditation Program (ELAP) certified and can conduct the analysis within the holding times specified in the approved methods in 40 C.F.R. part 136.

#### **7.5.4. Annual Best Management Practices (BMP) Plan and Storm Water Pollution Prevention Plan (SWPPP) Reporting**

Consistent with Order R6V-2017-0025, this Order requires annual certification that the BMP Plan and SWPPP meet the requirements of this Order and are being implemented as written.

#### **7.5.5. Visual Observations**

Consistent with Order R6V-2017-0025, this Order requires visual observations within 2 business days of a qualifying rain event to identify whether BMPs were adequately designed, implemented, and effective and to identify additional BMPs necessary. This Order also requires quarterly visual observations of non-storm water discharges to ensure that BMPs are being implemented and are effective.

#### **7.5.6. Discharge Monitoring Report-Quality Assurance (DMR-QA) Study Program**

Under the authority of section 308 of the CWA (33 U.S.C. § 1318), U.S. EPA requires major and selected minor dischargers under the NPDES Program to participate in the annual DMR-QA Study Program. The DMR-QA Study evaluates the analytical ability of

laboratories that routinely perform or support self-monitoring analyses required by NPDES permits. There are two options to satisfy the requirements of the DMR-QA Study Program: (1) The Discharger can obtain and analyze a DMR-QA sample as part of the DMR-QA Study; or (2) Per the waiver issued by U.S. EPA to the State Water Board, the Discharger can submit the results of the most recent Water Pollution Performance Evaluation Study from its own laboratories or its contract laboratories. A Water Pollution Performance Evaluation Study is similar to the DMR-QA Study. Thus, it also evaluates a laboratory's ability to analyze wastewater samples to produce quality data that ensure the integrity of the NPDES Program. The Discharger shall ensure that the results of the DMR-QA Study or the results of the most recent Water Pollution Performance Evaluation Study are submitted annually to the State Water Board. The State Water Board's Quality Assurance Program Officer will send the DMR-QA Study results or the results of the most recent Water Pollution Performance Evaluation Study to U.S. EPA's DMR-QA Coordinator and Quality Assurance Manager.

## 8. PUBLIC PARTICIPATION

The Lahontan Water Board has considered the issuance of WDRs that will serve as an NPDES permit for Mojave River Fish Hatchery. As a step in the WDR adoption process, the Lahontan Water Board staff has developed tentative WDRs and has encouraged public participation in the WDR adoption process.

### 8.1. Notification of Interested Parties

The Lahontan Water Board notified the Discharger and interested agencies and persons of its intent to prescribe WDRs for the discharge and provided an opportunity to submit written comments and recommendations. Notification to comment on the proposed Order was provided on the Lahontan Water Board Website and to all known interested parties on <DATE>. Notification was also provided through publications in the XXXXXXXXXX on <Date>. The public had access to the agenda and any changes in dates and locations through the Lahontan Water Board's website at <https://www.waterboards.ca.gov/lahontan/>.

### 8.2. Written Comments

Interested persons were invited to submit written comments concerning tentative WDRs as provided through the notification process. Comments were due either in person or by mail to the Executive Office at the Lahontan Water Board at the address on the cover page of this Order.

To be fully responded to by staff and considered by the Lahontan Water Board, the written comments were due at the Lahontan Water Board office by 5:00 p.m. on February 20, 2024.

### 8.3. Public Hearing

The Lahontan Water Board held a public hearing on the tentative WDRs during its regular Board meeting on the following date and time and at the following location:

Date: April 17, 2024  
Time: 1:00 PM

Location: Holiday Inn Express & Suites Barstow – Conference Room, 2700  
Lenwood Rd, Barstow, CA 92311  
AND  
Antelope Valley-East Kern Water Agency, 6500 W Ave N Palmdale,  
CA 93551

Interested persons were invited to attend. At the public hearing, the Lahontan Water Board heard testimony pertinent to the discharge, WDRs, and permit. For accuracy of the record, important testimony was requested in writing.

#### **8.4. Reconsideration of Waste Discharge Requirements**

Any person aggrieved by this action of the Lahontan Water Board may petition the State Water Board to review the action in accordance with Water Code section 13320 and California Code of Regulations, title 23, sections 2050 and following. The State Water Board must receive the petition by 5:00 p.m., within 30 calendar days of the date of adoption of this Order at the following address, except that if the thirtieth day following the date of this Order falls on a Saturday, Sunday, or state holiday, the petition must be received by the State Water Board by 5:00 p.m. on the next business day:

State Water Resources Control Board  
Office of Chief Counsel  
P.O. Box 100, 1001 I Street  
Sacramento, CA 95812-0100  
Or by email at [waterqualitypetitions@waterboards.ca.gov](mailto:waterqualitypetitions@waterboards.ca.gov)

For [instructions on how to file a water quality petition for review](#), see:  
([http://www.waterboards.ca.gov/public\\_notices/petitions/water\\_quality/wqpetition\\_instr.shtml](http://www.waterboards.ca.gov/public_notices/petitions/water_quality/wqpetition_instr.shtml))

#### **8.5. Information and Copying**

The Report of Waste Discharge, other supporting documents, and comments received are on file and may be inspected at the address above at any time between 8:30 a.m. and 4:45 p.m., Monday through Friday. Copying of documents may be arranged through the Lahontan Water Board by calling (530) 542-5400.

#### **8.6. Register of Interested Persons**

Any person interested in being placed on the mailing list for information regarding the WDRs and NPDES permit should contact the Lahontan Water Board, reference this facility, and provide a name, address, and phone number.

#### **8.7. Additional Information**

Requests for additional information or questions regarding this order should be directed to Lauder Fairchok at [lauder.fairchok@waterboards.ca.gov](mailto:lauder.fairchok@waterboards.ca.gov).

**ATTACHMENT G – AQUACULTURE DRUGS AND CHEMICALS APPROVED FOR USE**

Drug or Chemical	Purpose of Application	Expected Method(s) of Application or Treatment
Acetic acid	Control of external parasites.	<p><b>Flush:</b> 1.5 to 2.2 gallons of glacial acetic acid added as a bolus to top of raceway. Gives a treatment of level of approximately 335 to 500 ppm acetic acid.</p> <p><b>Bath:</b> used at a rate of 500 to 2,000 ppm for 1 to 10 minutes.</p>
Amoxicillin trihydrate	Control and prevention of external and systemic bacterial infections.	<p><b>Injected intraperitoneally:</b> into broodstock twice a week, prior to spawning, at a rate of 40 milligrams amoxicillin per kilogram of fish.</p>
Carbon Dioxide	Anesthetic.	<p><b>Bath:</b> bubbled in water. Usually used in small volumes of water.</p>
Chloramine-T. Halamide Aqua	Control of external gill bacteria.	<p><b>Flush or bath:</b> dosage of 12-20 ppm for one hour daily or every other day for three treatments.</p> <p><b>Bath:</b> used at a concentration of 20 ppm for one hour.</p>
Chorulon® - Chorionic Gonadotropin	Aid in improving spawning function	<p><b>Intramuscular injection: Males: 50-510 IU/lb, Females: 67-1816 IU/lb,</b></p>
Enteric Redmouth (ERM) Vaccine	Prevent Redmouth disease	<p><b>Dip. Vaccine dumped after use. Not surface discharged.</b></p>
Epsom Salt (Magnesium Sulfate)	Control internal parasites.	<p><b>Feed:</b> used in “medicated” feed or fish pills at a rate of 100 milligrams per kilogram of fish or top coated onto feed at 3% (30 gms per kg) for 3 days..</p>
Erythromycin	Control and prevention of external and systemic bacterial infections.	<p><b>Injected intraperitoneally:</b> at a rate of 40 milligrams erythromycin per kilogram of fish, at 30 day intervals.</p> <p><b>Feed:</b> used in medicated feed or fish pills at a rate of 100 milligrams or less of erythromycin per kilogram of fish.</p>



Drug or Chemical	Purpose of Application	Expected Method(s) of Application or Treatment
Florfenicol (Aquaflor)	Control and prevention of external and systemic bacterial infections.	<b>Medicated Feed:</b> 10-15 mg/kg of fish for 10 consecutive days.
Formalin (37% formaldehyde solution)	Control of external parasites.  Fungus control on fish eggs.	<b>Flush:</b> Low dose - used at a concentration of 25 ppm of formalin for 8 hours. High dose - used at a concentration of 50 to 250 ppm formalin for one hour for three treatments or as prescribed..  <b>Bath:</b> used at a concentration of 2,000 ppm formalin, or less, for 15 minutes. Repeat in 5 to 10 days unless or as prescribed.
Hydrogen peroxide	Control of external parasites.	<b>Flush:</b> used at a rate of 100 ppm, or less, for 30 minutes to 1 hour every other day for up to three treatments or as prescribed.
Ivermectin	Control of parasites	<b>Injected intramuscularly: (0.1 mg/kg) once a week up to two injections or as prescribed.</b>
MS-222 / tricaine methanesulfonate (Finquel®, Tricaine-S®)	Anesthetic or euthanasia.	<b>Bath:</b> used at a rate of 50 to 1,000 mg/L, usually in a small volume of water.
Ovaplant® Salmon Gonadotropin-releasing hormone analogue (sGnRHa)	Induce gamete maturation	<b>Dorsal injection pellet-implant:</b> 10 - 75 microgram (µg) sGnRHa per kilogram (kg) body weight. Maximum 150 µg sGnRHa per kg body weight in certain situations involving very small brood fish (e.g. fish <1 kg bw) or as prescribed.
Oxytetracycline HCl (Terramycin®)	Control and prevention of external and systemic bacterial infections.	<b>Bath:</b> used in tanks for six to eight hours at a concentration of 100 ppm or less.
Oxytetracycline dihydrate (Terramycin® 200)	Antibiotic and bacteriostat.	<b>Additive to feed:</b> 3.75 g/100 lbs of fish/day for 10 days.
Penicillin G potassium	Control and prevention of external and systemic bacterial infections.	<b>Bath:</b> used in tanks for six to eight hours at a concentration of 150 IU/ml (500,000,000 IU/311.8 gm. Packet).

Drug or Chemical	Purpose of Application	Expected Method(s) of Application or Treatment
Potassium Permanganate (Cairox™)	Control of external parasites and bacteria.	<b>Flush:</b> up to 2 ppm at one hour for up to 3 consecutive treatment days. <b>Bath:</b> used at a rate of 2 ppm, or less, for one hour.
PVP Iodine	Disinfect and control diseases on fish eggs.	<b>Bath:</b> used at a concentration of 100 mg/L for 10 to 30 minutes.
SLICE (emamectin benzoate;0.2% aquaculture premix)	Copepods	<b>Medicated feed:</b> 50 µg emamectin benzoate/Kg of fish biomass/day for 7 consecutive days.
Sodium bicarbonate	Anesthetic.	<b>Bath:</b> used at a rate of 142 to 642 mg/L, usually in a small volume of water.
Sodium chloride (salt)	Fish cleansing, disease control, and stress reduction.	<b>Flush:</b> used at a rate of up to 333‰ for 1 hour, daily if needed. Or at a lesser concentration during transport.
Sulfadimethoxine-ormetoprim (Romet-30®)	Control and prevention of external and systemic bacterial infections.	<b>Feed:</b> used at a rate of 50 milligrams of drug per kilogram of fish per day.
Vibrio vaccine	Prevention of Vibrio infections	<b>Dip: Vaccine dumped after use. Not discharged.</b>



### DRUG AND CHEMICAL NON-USE TABLE

Drug or Chemical Name	Reporting Quarter	Used or Not Used
Acetic acid		
Amoxicillin trihydrate		
Carbon Dioxide		
Chloramine-T. Halamide Aqua		
Chorulon® - Chorionic Gonadotropin		
Enteric Redmouth (ERM) Vaccine		
Epson Salt (Magnesium Sulfate)		
Erythromycin		
Florfenicol (Nuflor®)		
Formalin (37% formaldehyde solution)		
Hydrogen peroxide		
Ivermectin		
MS-222 / tricaine methanesulfonate (Finquel®, Tricaine-S®)		
Ovaplant®		
Salmon Gonadotropin-releasing hormone analogue (sGnRH <sub>a</sub> )		
Oxytetracycline HCl (Terramycin®)		
Oxytetracycline dihydrate (Terramycin® 200)		
Penicillin G potassium		
Potassium Permanganate (Cairox™)		
PVP Iodine		
SLICE (emamectin benzoate;0.2% aquaculture premix)		
Sodium bicarbonate		
Sodium chloride (salt)		
Sulfadimethoxine-ormetoprim (Romet-30®)		
Vibrio vaccine		
List Other Chemical and Drugs used		

# ATTACHMENT I – STORM WATER POLLUTION PREVENTION PLAN REQUIREMENTS

## 1. Objectives

The SWPPP has two major objectives: (a) to identify and evaluate sources of pollutants associated with Facility activities that may affect the quality of storm water discharges and authorized non-storm water discharges from the Facility; and (b) to identify and implement site-specific best management practices (BMPs) to reduce or prevent pollutants associated with Facility activities in storm water discharges and authorized non-storm water discharges. BMPs may include a variety of pollution prevention measures or other low-cost and pollution control measures. They are generally categorized as non-structural BMPs (activity schedules, prohibitions of practices, maintenance procedures, and other low-cost measures) and as structural BMPs (treatment measures, run-off controls, overhead coverage.) To achieve these objectives, the Discharger must consider the five phase process for SWPPP development and implementation as shown in Table I-1.

The SWPPP requirements are designed to be sufficiently flexible to meet the needs of the Facility. SWPPP requirements that are not applicable to the Facility should not be included in the SWPPP.

A SWPPP is a written document that must contain a compliance activity schedule, a description of Facility activities and pollutant sources, descriptions of BMPs, drawings, maps, and relevant copies or references of parts of other plans. The SWPPP must be revised whenever appropriate, at least annually, and must be readily available for review by facility employees or Lahontan Water Board inspectors.

**Table I-1. Five Phases for Developing and Implementing Industrial SWPPPs**

<b>PLANNING AND ORGANIZATION</b> Form Pollution Prevention Team Review other plans
<b>ASSESSMENT PHASE</b> Develop a site map Identify potential pollutant sources Inventory of materials and chemicals List significant spills and leaks Identify non-storm water discharges Assess pollutant risks
<b>BEST MANAGEMENT PRACTICES IDENTIFICATION PHASE</b> Non-structural BMPs Structural BMPs Select activity and site-specific BMPs
<b>IMPLEMENTATION PHASE</b> Train employees Implement BMPs Conduct recordkeeping and reporting

## **EVALUATION / MONITORING**

Conduct annual site evaluation  
Review monitoring information  
Evaluate BMPs  
Review and revise SWPPP

## **2. Planning and Organization**

The SWPPP must identify a specific individual or individuals and their positions within the Discharger's organization as members of a storm water pollution prevention team responsible for developing the SWPPP, assisting the Facility manager in SWPPP implementation and revision, and conducting all monitoring program activities. The SWPPP must clearly identify the Permit-related responsibilities, duties, and activities of each team member. Storm water pollution prevention teams may consist of one individual where appropriate.

## **3. Site Map**

The SWPPP must include a site map. The site map size must be at least 8-½ x 11 inches but no larger than 11 X 17 inches and include notes, legends, and other data as appropriate to ensure that the site map is clear and understandable. If necessary, facility operators may provide the required information on multiple site maps.

The following information must be included on the site map:

- 3.1. The Facility boundaries; the outline of all storm water drainage areas within the Facility boundaries; portions of the drainage area impacted by run-on from surrounding areas; and direction of flow of each drainage area, on-site surface water bodies, and areas of soil erosion. The map must also identify nearby water bodies and storm drain inlets where the facility's storm water discharges and authorized non-storm water discharges may be received.
- 3.2. The location of the storm water collection and conveyance system, associated points of discharge, and direction of flow. Include any structural control measures that affect storm water discharges, authorized non-storm water discharges, and run-on. Examples of structural control measures are catch basins, berms, detention ponds, secondary containment, oil/water separators, diversion barriers, etc.
- 3.3. An outline of all impervious areas of the Facility, including paved areas, buildings, covered storage areas, or other roofed structures.
- 3.4. Locations where materials are directly exposed to precipitation and the locations where significant spills or identified leaks have occurred.
- 3.5. Locations of all chemical storage areas and storage tanks, fueling areas, vehicle and equipment storage/maintenance areas, cleaning and rinsing areas, and other areas of activity which are potential pollutant sources.

## **4. List of Significant Materials**

The SWPPP must include a list of significant materials handled and stored at the Facility. For each material on the list, describe the locations where the material is being stored, as well as the typical quantities.

## 5. Description of Potential Pollutant Sources

- 5.1. The SWPPP must include a narrative description of the Facility activities, associated potential pollutant sources, and potential pollutants that could be discharged in storm water discharges or authorized non-storm water discharges. At a minimum, the following items related to the Facility's activities must be considered:
  - 5.1.1. Describe the type, characteristics, and quantity of significant materials used in or stored on site and a description of the cleaning, rinsing, disposal, or other activities related to Facility's operation. Where applicable, areas protected by containment structures and the corresponding containment capacity must be described.
  - 5.1.2. **Material Handling and Storage Areas.** Describe each handling and storage area, type, characteristics, and quantity of significant materials handled or stored and the spill or leak prevention and response procedures. Where applicable, areas protected by containment structures and the corresponding containment capacity must be described.
  - 5.1.3. Describe materials that have spilled or leaked in significant quantities in storm water discharges or non-storm water discharges. The description must include the type, characteristics, and approximate quantity of the material spilled or leaked, the cleanup or remedial actions that have occurred or are planned, the approximate remaining quantity of materials that may be exposed to storm water or non-storm water discharges, and the preventative measures taken to ensure spill or leaks do not reoccur.
  - 5.1.4. **Non-Storm Water Discharges.** Investigate the Facility to identify all non-storm water discharges and their sources. As part of this investigation, all drains (inlets and outlets) must be evaluated to identify whether they connect to a storm drain system. (Examples of prohibited non-storm water discharges are contact and non-contact cooling water, rinse water, wash water, etc.). The SWPPP must include BMPs to prevent or reduce contact of non-storm water discharges with significant materials or equipment.
- 5.2. The SWPPP must include a summary of all areas potential pollutant sources, and potential pollutants. This information should be summarized similar to Table I-2.

**Table I-2. Example Assessment of Potential Pollutant Sources and Corresponding BMP Summary**

Area	Activity	Source	Pollutant	Best Management Practices
Vehicle & Equipment Fueling	Fueling	Spills and leaks during delivery. Spills caused by topping off fuel tanks. Hosing or washing down fuel oil fuel area. Leaking storage tanks. Rainfall running off fuel oil, and rainfall running onto and off fueling area.	fuel oil	Use spill and overflow protection. Minimize run-on of storm water into the fueling area. Cover fueling area. Use dry cleanup methods rather than hosing down area. Implement proper spill prevention control program. Implement adequate preventative maintenance program to preventive tank and line leaks. Inspect fueling areas regularly to detect problems before they occur. Train employees on proper fueling, cleanup, and spill response techniques.

**6. Assessment of Potential Pollutant Sources**

- 6.1. The SWPPP must include a narrative assessment of all Facility activities and potential pollutant sources to determine:
  - 6.1.1. Which areas of the Facility are likely sources of pollutants in storm water discharges and authorized non-storm water discharges, and
  - 6.1.2. Which pollutants are likely to be present in storm water discharges and authorized non-storm water discharges. Facility operators must consider and evaluate various factors when performing this assessment such as current storm water BMPs; quantities of significant materials stored or disposed of; likelihood of exposure to storm water or
  - 6.1.3. authorized non-storm water discharges; history of spill or leaks; and run-on from outside sources.
- 6.2. Facility operators must summarize the areas of the facility that are likely sources of pollutants and the corresponding pollutants that are likely to be present in storm water discharges and authorized non-storm water discharges. Facility operators are required to develop and implement additional BMPs as appropriate and necessary to prevent or reduce pollutants associated with each pollutant source.



## 7. Storm Water Best Management Practices

The SWPPP must include a narrative **description** of the storm water BMPs to be implemented at the Facility for each potential pollutant and its source identified in the site assessment phase. The BMPs must be developed and implemented to reduce or prevent pollutants in storm water discharges and authorized non-storm water discharges. Each pollutant and its source may require one or more BMPs. Some BMPs may be implemented for multiple pollutants and their sources, while other BMPs will be implemented for a very specific pollutant and its source.

The description of the BMPs must identify the BMPs as (1) existing BMPs, (2) existing BMPs to be revised and implemented, or (3) new BMPs to be implemented along with a schedule for implementation. The description must also include a discussion on the effectiveness of each BMP to reduce or prevent pollutants in storm water discharges and authorized non-storm water discharges. The SWPPP must provide a summary of all BMPs implemented for each pollutant source. This information should be summarized similar to Table I-2.

Facility operators must consider the following BMPs for implementation at the Facility:

### 7.1. Non-Structural BMPs

Non-structural BMPs generally consist of processes, prohibitions, procedures, schedule of activities, etc., that prevent pollutants associated with activity from contacting with storm water discharges and authorized non-storm water discharges. They are considered low technology, cost-effective measures. The Discharger and its Facility operator must consider all possible non-structural BMPs options before considering additional structural BMPs. Below is a list of non-structural BMPs that should be considered:

- 7.1.1. **Good Housekeeping.** Good housekeeping generally consists of practical procedures to maintain a clean and orderly facility.
- 7.1.2. **Preventive Maintenance.** Preventive maintenance includes the regular inspection and maintenance of structural storm water controls (catch basins, oil/water separators, etc.) as well as other facility equipment and systems.
- 7.1.3. **Spill Response.** This includes spill clean-up procedures and necessary clean-up equipment based upon the quantities and locations of significant materials that may spill or leak.
- 7.1.4. **Material Handling and Storage.** This includes all procedures to minimize the potential for spills and leaks and to minimize exposure of significant materials to storm water and authorized non-storm water discharges.
- 7.1.5. **Employee Training.** This includes training of personnel who are responsible for (1) implementing activities identified in the SWPPP, (2) conducting inspections, sampling, and visual observations, and (3) managing storm water. Training should address topics such as spill response, good housekeeping, and material handling procedures, and actions necessary to implement all BMPs identified in the SWPPP. The SWPPP must identify periodic dates for such training. Records must be maintained of all training sessions held.
- 7.1.6. **Waste Handling/Recycling.** This includes the procedures or processes to handle, store, or dispose of waste materials or recyclable materials.

- 7.1.7. **Recordkeeping and Internal Reporting.** This includes the procedures to ensure that all records of inspections, spills, maintenance activities, corrective actions, visual observations, etc., are developed, retained, and provided, as necessary, to the appropriate facility personnel.
- 7.1.8. **Inspections.** This includes, in addition to the preventative maintenance inspections identified above, an inspection schedule of all potential pollutant sources. Tracking and follow-up procedures must be described to ensure adequate corrective actions are taken and necessary modifications to the site SWPPP are made.
- 7.1.9. **Quality Assurance.** This includes the procedures to ensure that all elements of the SWPPP and Monitoring Program are adequately conducted.

## 7.2. Structural BMPs

Where non-structural BMPs as identified above are not effective, structural BMPs must be considered. Structural BMPs generally consist of structural devices that reduce or prevent pollutants in storm water discharges and authorized non-storm water discharges. Below is a list of structural BMPs that should be considered:

- 7.2.1. **Overhead Coverage.** This includes structures that provide horizontal coverage of materials, chemicals, and pollutant sources from contact with storm water and authorized non-storm water discharges.
- 7.2.2. **Retention Ponds.** This includes basins, ponds, surface impoundments, bermed areas, etc. that do not allow storm water to discharge from the facility.
- 7.2.3. **Control Devices.** This includes berms or other devices that channel or route run-on and runoff away from pollutant sources.
- 7.2.4. **Secondary Containment Structures.** This generally includes containment structures around storage tanks and other areas for the purpose of collecting any leaks or spills.
- 7.2.5. **Treatment.** This includes inlet controls, infiltration devices, oil/water separators, detention ponds, vegetative swales, etc., that reduce the pollutants in storm water discharges and authorized non-storm water discharges.

## 8. SWPPP General Requirements

- 8.1. The SWPPP must be retained on site and made available upon request of a representative of the Lahontan Water Board.
- 8.2. The Lahontan Water Board may notify the Facility operator when the SWPPP does not meet one or more of the minimum requirements of this Section. As requested by the Lahontan Water Board, the Discharger must submit a SWPPP revision and implementation schedule.
- 8.3. The SWPPP must be revised, as appropriate, and implemented prior to changes which (i) may significantly increase the quantities of pollutants in storm water discharge, (ii) cause a new area of industrial activity at the facility to be exposed to storm water, or (iii) begin an activity which would introduce a new pollutant source at the facility.
- 8.4. When any part of the SWPPP is infeasible to implement due to proposed significant structural changes, the Discharger must submit a report to the Lahontan Water Board that (i) describes the portion of the SWPPP that is infeasible to implement, (ii) provides justification for a time extension, (iii) provides a schedule for completing and implementing

that portion of the SWPPP, and (iv) describes the BMPs that will be implemented in the interim period to reduce or prevent pollutants in storm water discharges and authorized non-storm water discharges. Such reports are subject to Water Board approval and/or modification.

- 8.5. The SWPPP is considered a report that must be available to the public by the Lahontan Water Board under Section 308(b) of the Clean Water Act.

## **9. Annual Comprehensive Site Compliance Evaluation**

The Discharger must conduct one annual comprehensive site compliance evaluation in the period January 1–December 31. Evaluations must be conducted within 8–16 months of each other. The SWPPP must be revised, as appropriate, and the revisions implemented within 90 days of the evaluation. Evaluations must include the following:

- 9.1. A review of all visual observation records, inspection records, and sampling and analysis results.
- 9.2. A visual inspection of all potential pollutant sources for evidence of, or the potential for, pollutants entering the drainage system.
- 9.3. A review and evaluation of all BMPs (both structural and non-structural) to determine whether the BMPs are adequate, properly implemented and maintained, or whether additional BMPs are needed. A visual inspection of equipment needed to implement the SWPPP, such as spill response equipment, must be included.
- 9.4. An evaluation report that includes, (i) identification of personnel performing the evaluation, (ii) the date(s) of the evaluation, (iii) necessary SWPPP revisions, and (v) any incidents of noncompliance and the corrective actions taken. The evaluation report must be submitted as part of the site's annual report and retained for at least five years.

## ATTACHMENT J – PRIORITY POLLUTANT MONITORING REQUIREMENTS

**1. Background.** The Lahontan Water Board previously determined that, based on priority pollutant data collected from concentrated aquatic animal production (CAAP) facilities, discharge of priority pollutants other than metals was unlikely. It has been over two permit terms since a full list of priority pollutant list was collected. Accordingly, the Lahontan Water Board is requiring, as part of the Monitoring and Reporting Program, that the Discharger sample the effluent and analyze the samples for a full priority pollutant list. Sections 2.4.1 through 2.4.4 of the *Policy for Implementation of Toxics Standards for Inland Surface Waters, Enclosed Bays, and Estuaries of California* (State Implementation Policy or SIP) provide minimum standards for analyses and reporting. (Copies of the SIP may be obtained from the State Water Resources Control Board or downloaded from [http://waterboards.ca.gov/water\\_issues/programs/state\\_implementation\\_policy/docs/final.pdf](http://waterboards.ca.gov/water_issues/programs/state_implementation_policy/docs/final.pdf).) As the hatchery is supplied by groundwater and the Mojave River typically flows underground, influent pH and hardness are required to evaluate the toxicity of metals where the toxicity of the constituents varies with pH and/or hardness. CTR pollutants will be collected during this permit term and may be reconsidered for removal from monitoring requirements with the development of next term's permit.

On May 2, 2017, the State Water Resources Control Board adopted Resolution 2017-0027, which approved "Part 2 of the Water Quality Control Plan for Inland Surface Waters, Enclosed Bays, and Estuaries of California—Tribal and Subsistence Fishing Beneficial Uses and Mercury Provisions." Resolution 2017-0027 provides a consistent regulatory approach throughout the state by setting mercury limits to protect the beneficial uses associated with the consumption of fish by both people and wildlife.

**2. Minimum Level (ML) and Analytical Method Selection:** U.S. EPA published regulations for the Sufficiently Sensitive Methods Rule (SSM Rule) which became effective September 18, 2015. For the purposes of the NPDES program, when more than one test procedure is approved under 40 C.F.R. part 136 for the analysis of a pollutant or pollutant parameter, the test procedure must be sufficiently sensitive as defined at 40 C.F.R. 122.21(e)(3) and 122.44(i)(1)(iv). Both 40 C.F.R sections 122.21(e)(3) and 122.44(i)(1)(iv) apply to the selection of a sufficiently sensitive analytical method for the purposes of monitoring and reporting under NPDES permits, including review of permit applications. A U.S. EPA-approved analytical method is sufficiently sensitive where:

- a) The ML is at or below both the level of the applicable water quality criterion/objective and the permit limitation for the measured pollutant or pollutant parameter; or
- b) In permit applications, the ML is above the applicable water quality criterion/objective, but the amount of the pollutant or pollutant parameter in a facility's discharge is high enough that the method detects and quantifies the level of the pollutant or pollutant parameter in the discharge; or
- c) The method has the lowest ML of the U.S. EPA-approved analytical methods where none of the U.S. EPA-approved analytical methods for a pollutant can achieve the MLs necessary to assess the need for effluent limitations or to monitor compliance with a permit limitation.

The MLs in SIP Appendix 4 remain applicable. However, there may be situations when analytical methods are published with MLs that are more sensitive than the MLs for analytical methods listed in the SIP. For instance, U.S. EPA Method 1631E for mercury is not currently listed in SIP Appendix 4, but it is published with an ML of 0.5 ng/L that makes it a sufficiently sensitive analytical method. Similarly, U.S. EPA Method 245.7 for mercury is published with an ML of 5 ng/L.

- 3. Monitoring Requirements.** Priority pollutant all samples must be collected for the influent at Monitoring Location INF-001 and effluent at Monitoring Location EFF-001 and analyzed for the constituents listed in Table J-1 **one time in the year 2027 and reported to the Lahontan Water Board no later than February 1, 2028 in the SMR, and included in the ROWD.**
- 4. Monitoring Plan.** By **March 1, 2027** the Discharger must submit a Priority Pollutant Monitoring Plan electronically via California Integrated Water Quality System (CIWQS) submittal outlining reporting levels (RLs), method detection limits (MDLs), and analytical methods for the priority pollutant metals identified in Attachment J. Three months prior to collecting the required Priority Pollutant samples, the Discharger must notify the Water Board of the Environmental Laboratory Accreditation Program (ELAP) certified laboratory to be used that can conduct the analysis within the holding times specified in the approved methods in 40 C.F.R. part 136. The Discharger must comply with the monitoring and reporting requirements for the priority pollutant metals as outlined in section 2.3 and 2.4 of the SIP. The maximum required reporting levels for the priority pollutant metals must be based on the Minimum Levels (MLs) contained in Appendix 4 of the SIP, determined in accordance with section 2.4.2 and section 2.4.3 of the SIP. In accordance with section 2.4.2 of the SIP, when there is more than one ML value for a given substance, the Lahontan Water Board must include as RLs, in the permit, all ML values, and their associated analytical methods, listed in Appendix 4 that are below the calculated effluent limitation. The Discharger may select any one of those cited analytical methods for compliance determination. If no ML value is below the effluent limitation, then the Lahontan Water Board must select as the RL, the lowest ML value, and its associated analytical method, listed in Appendix 4 for inclusion in the permit. Table J-1 provides required maximum reporting levels in accordance with the SIP.

**Table J-1. List of Required Priority Pollutants <sup>1,5</sup>**

CTR No.	Constituent	Controlling Water Quality Criterion for Surface Waters		Maximum Reporting Level <sup>2</sup> µg/L
		Basis	Criterion Concentration µg/L	
1	Antimony	Primary MCL	6.0	5
2	Arsenic	Primary MCL	10	10
3	Beryllium	Primary MCL	4	2
4	Cadmium	CTR Aquatic Life	2.9	0.5
5a	Chromium (III)	CTR Aquatic Life	240	50
5b	Chromium (VI)	CTR Aquatic Life	11	10
6	Copper	CTR Aquatic Life	11	10
7	Lead	CTR Aquatic Life	4.1	2
8	Mercury	Statewide Mercury Provisions <sup>3</sup>	0.012	0.005 <sup>4</sup>
9	Nickel	CTR Aquatic Life	62	50
10	Selenium	CTR Aquatic Life	5	5
11	Silver	CTR Aquatic Life	5.6	2
12	Thallium	CTR Human Health	1.7	1
13	Zinc	CTR Aquatic Life	140	20
14	Cyanide	CTR Aquatic Life	5.2	5
15	Asbestos	CTR Human Health	7.0	6

16	2,3,7,8,-TCDD (Dioxin)			6
17	Acrolein	CTR Human Health	780	6
18	Acrylonitrile	CTR Human Health	.66	6
19	Benzene	CTR human health- fish consumption	71	6
20	Bromoform	CTR Human Health	360	6
21	Carbon Tetrachloride	CTR Human Health	4.4	6
22	Chlorobenzene	CTR Human Health	21,000	6
23	Chlorodibromomethane	CTR Human Health	34	6
25	2-Chloroethylvinyl ether		No Criteria	6
26	Chloroform		No Criteria	6
27	Dichlorobromomethane	CTR Human Health	46	6
28	1,1-Dichloroethane		No Criteria	6
29	1,2-Dichloroethane	CTR Human Health	99	6
30	1,1-Dichloroethylene	CTR Human Health	3.2	6
31	1,2-Dichloropropane	CTR Human Health	39	6
32	1,3-Dichloropropylene	CTR Human Health	1700	6
33	Ethylbenzene	CTR Human Health	29,000	6
34	Methyl Bromide	CTR Human Health	4,000	6
35	Methyl Chloride		No Criteria	6
36	Methylene Chloride	CTR Human Health	1600	6
37	1,1,2,2-Tetrachloroethane	CTR Human Health	11	6
38	Tetrachloroethylene	CTR Human Health	8.9	6
39	Toluene	Primary MCL	150	6
40	1,2-Trans-Dichloroethylene		0.010	6
41	1,1,1-Trichloroethane	Primary MCL	200	6
42	1,1,2-Trichloroethane	CTR Human Health	0.60	6

43	Trichloroethylene	CTR Human Health	2.7	6
44	Vinyl Chloride	Primary MCL	0.50	6
45	2-Chlorophenol	CTR Human Health	120	6
46	2,4-Dichlorophenol	CTR Human Health	93	6
47	2,4-Dimethylphenol	CTR Human Health	540	6
48	2-Methyl-4,6-Dinitrophenol	CTR Human Health	13	6
49	2,4-Dinitrophenol	CTR Human Health	70	6
50	2-Nitrophenol		No Criteria	6
51	4-Nitrophenol		No Criteria	6
52	3-Methyl-4-Chlorophenol		No Criteria	6
53	Pentachlorophenol	CTR Human Health	0.28	6
54	Phenol	CTR Human Health	21,000	6
55	2,4,6-Trichlorophenol	CTR Human Health	2.1	6
56	Acenaphthene	CTR Human Health	1,200	6
57	Acenaphthylene		No Criteria	6
58	Anthracene	CTR Human Health	9,600	6
59	Benzidine	CTR Human Health	0.00012	6
60	Benzo(a)Anthracene	CTR Human Health	0.0044	6
61	Benzo(a)Pyrene	CTR Human Health	0.0044	6
62	Benzo(b)Fluoranthene	CTR Human Health	0.0044	6
63	Benzo(ghi)Perylene		No Criteria	6
64	Benzo(k)Fluoranthene	CTR Human Health	0.0044	6
65	Bis(2-Chloroethoxy)Methane		No Criteria	6
66	Bis(2-Chloroethyl)Ether		0.013	6
67	Bis(2-Chloroisopropyl)Ether		1,400	6
68	Bis(2-Ethylhexyl)Phthalate		1.8	6
69	4-Bromophenyl Phenyl Ether		No Criteria	6
70	Butylbenzyl Phthalate	CTR Human Health	3,000	6
71	2-Chloronaphthalene	CTR Human Health	1,700	6



72	4-Chlorophenyl Phenyl Ether		No Criteria	6
73	Chrysene	CTR Human Health	0.0044	6
74	Dibenzo(a,h)Anthracene	CTR Human Health	0.0044	6
75	1,2 Dichlorobenzene	Primary MCL	600	6
76	1,3 Dichlorobenzene	CTR Human Health	400	6
77	1,4 Dichlorobenzene	Primary MCL	5.0	6
78	3,3'-Dichlorobenzidine		0.040	6
79	Diethyl Phthalate	CTR Human Health	23,000	6
80	Dimethyl Phthalate	CTR Human Health	313,000	6
81	Di-n-Butyl Phthalate	CTR Human Health	2,700	6
82	2,4-Dinitrotoluene	CTR Human Health	0.11	6
83	2,6-Dinitrotoluene		No Criteria	6
84	Di-n-Octyl Phthalate		No Criteria	6
85	1,2-Diphenylhydrazine	CTR Human Health	0.040	6
86	Fluoranthene	CTR Human Health	300	6
87	Fluorene	CTR Human Health	1,300	6
88	Hexachlorobenzene	CTR Human Health	0.00075	6
89	Hexachlorobutadiene	CTR Human Health	0.44	6
90	Hexachlorocyclopentadiene	Primary MCL	50	6
91	Hexachloroethane	CTR Human Health	1.9	6
92	Indeno(1,2,3-cd) Pyrene		0.0044	6
93	Isophorone	CTR Human Health	8.4	6
94	Naphthalene		No Criteria	6
95	Nitrobenzene	CTR Human Health	17	6
96	N-Nitrosodimethylamine	CTR Human Health	0.00069	6
97	N-Nitrosodi-n-Propylamine	CTR Human Health	0.0050	6
98	N-Nitrosodiphenylamine	CTR Human Health	5.0	6

99	Phenanthrene		No Criteria	6
100	Pyrene	CTR Human Health	960	6
101	1,2,4-Trichlorobenzene	Primary MCL	5.0	6
102	Aldrin	CTR Human Health	0.00013	6
103	alpha-BHC	CTR Human Health	0.0039	6
104	beta-BHC	CTR Human Health	0.014	6
105	gamma-BHC	CTR Human Health	0.019	6
106	delta-BHC		No Criteria	6
107	Chlordane	CTR Human Health	0.00057	6
108	4,4'-DDT		0.00059	6
109	4,4'-DDE		0.00059	6
110	4,4'-DDD		0.00083	6
111	Dieldrin	CTR Human Health	0.00014	6
112	alpha-Endosulfan	CTR Aquatic Life	0.056	6
113	beta-Endosulfan	CTR Aquatic Life	0.056	6
114	Endosulfan Sulfate	CTR Human Health	110	6
115	Endrin	CTR Aquatic Life	0.036	6
116	Endrin Aldehyde	CTR Human Health	0.76	6
117	Heptachlor	CTR Human Health	0.00021	6
118	Heptachlor Epoxide	CTR Human Health	0.00010	6
119-125	Polychlorinated biphenyls (PCBs)		0.00017	6
126	Toxaphene	CTR Aquatic Life	0.0002	6

**Table J-1 Notes:**

1. Monitoring must be conducted according to test procedures approved under 40 C.F.R. part 136.
2. The reporting levels required in this table for priority pollutant constituents are established based on section 2.4.2 and Appendix 4 of the SIP, except Chromium (VI).

3. *Final Part 2 of the Water Quality Control Plan for Inland Surface Waters, Enclosed Bays, and Estuaries of California—Tribal and Subsistence Fishing Beneficial Uses and Mercury Provisions.*
4. Total mercury samples collected as part of the CTR priority pollutant metals sampling requirement must be taken using clean hands/dirty hands procedures, as described in U.S. EPA method 1669: Sampling Ambient Water for Trace Metals at EPA Water Quality Criteria Levels, for collection of equipment blanks (section 9.4.4.2). The analysis of total mercury must be by U.S. EPA Method 245.7 (Revision E) with a reporting limit of 5 ng/L (0.005 µg/L).
5. The Discharger must sample for Hardness of the effluent and influent during priority pollutant metal sampling and include in the priority pollutant metal sampling report represented as [mg/L as CaCO<sub>3</sub>]
6. Water quality sampling and analysis must be accomplished by an approved EPA method. The method must be sufficiently sensitive for the method detection limit to be below the criteria concentration in the above table.

### ATTACHMENT K – FEED CONVERSION RATIOS LOG

The Discharger must utilize the following form to keep track of feeding and to calculate/track feed conversion ratios. The first row is an example row. Feed conversion ratios must be calculated using the following equation:

$$\text{Feed Conversion Ratio} = \frac{\text{Dry weight of feed applied}}{\text{Wet weight of fish gained}}$$

Date (start date end date)	Description of Group	Total Feed Amounts (Estimate)	Weight of Animals (start weight end weight)	Weight Gained	Calculated Feed Conversion Ratio
3/20/04	Brook trout stockers for Potomac River	5,275 lbs	100 lbs	4,700 lbs	1.12
10/21/04			4,800		

