

Coordinated Integrated Monitoring Program (CIMP)

for the Upper Los Angeles River Watershed

Prepared for

Upper Los Angeles River Watershed Management Group



Preparation Lead



In Conjunction with the Black & Veatch Team

CH2M HILL

Paradigm Environmental

Table of Contents

1	Introduction	1
1.1	Enhanced Watershed Management Program Area	1
1.2	Water Quality Priorities	5
1.3	CIMP Overview	6
1.3.1	Receiving Water Monitoring	6
1.3.2	Stormwater Outfall Monitoring	6
1.3.3	Non-Stormwater Outfall Program	7
1.3.4	New Development and Redevelopment Effectiveness Tracking	7
1.3.5	Trash Monitoring	7
1.3.6	Regional Studies	7
2	Receiving Water Monitoring Program	9
2.1	Receiving Water Monitoring Sites	9
2.1.1	Long Term Assessment Monitoring Sites	13
2.1.2	TMDL Sites	13
2.2	Monitored Parameters and Frequency of Monitoring	15
2.3	Weather Conditions	21
2.4	Monitoring Coordination	22
2.5	Receiving Water Monitoring Summary	22
3	MS4 Infrastructure Database	24
3.1	Available Information	24
3.2	Pending Information and Schedule for Completion	25
4	Stormwater Outfall Monitoring	26
4.1	Stormwater Outfall Monitoring Sites	26
4.2	Monitored Parameters and Frequency	35
4.3	Stormwater Outfall Monitoring Summary	38
5	Non-Stormwater Outfall Program	39
5.1	Non-Stormwater Outfall Screening and Monitoring Program	39
5.2	Identification of Outfalls with Significant Non-Stormwater Discharges	42
5.3	Inventory of MS4 Outfalls with Non-Stormwater Discharges	43
5.4	Prioritized Source Identification	44
5.5	Significant Non-Stormwater Discharge Source Identification	45
5.6	Non-Stormwater Discharge Monitoring	46

5.6.1	Non-Stormwater Outfall-Based Monitoring Sites	47
5.6.2	Monitored Parameters and Frequency of Monitoring.....	47
5.7	Non-Stormwater Outfall Monitoring Summary.....	50
6	Trash Monitoring.....	51
7	New Development/Re-Development Effectiveness Tracking	52
8	Regional Studies	54
9	Special Studies.....	55
10	Non-Direct Measurements	56
11	Adaptive Management.....	58
11.1	Integrated Monitoring and Assessment Program.....	58
11.2	CIMP Revision Process	58
12	Data Management and Reporting	61
13	Schedule for CIMP Implementation	62
14	References.....	68

List of Figures

Figure 1.	Upper Los Angeles River Watershed Management Area Group	4
Figure 2.	Overview of Receiving Water Monitoring Sites.....	12
Figure 3.	Stormwater Outfall Monitoring Locations Overview	34
Figure 4.	NSW Outfall Program Flow Diagram.....	42
Figure 5.	Implementation Schedule for Major CIMP Elements.....	65
Figure 6.	Typical Duration for the Establishment of a New Sampling Station Assuming a Streamlined Process	66
Figure 7.	Summary of Phased Screening and Monitoring Initiation Dates Consistent with the LAR Bacteria TMDL Load Reduction Strategy (LRS) Requirements	67

List of Tables

Table 1.	Waterbodies Associated with the Upper Los Angeles River Watershed Management Area Group EWMP	2
Table 2.	TMDLs Applicable to the Upper Los Angeles River Watershed EWMP	3
Table 3.	List of Jurisdictions Participating in the ULARWMAG with Land Use Summaries.....	5
Table 4.	Receiving Water Monitoring Sites	11

Table 5. Summary of Parameters to be Monitored at Receiving Water Monitoring Sites and Annual Frequency (wet/dry)	16
Table 6. Summary of Constituents to be Monitored at ULARWMAG Los Angeles River Tributary Receiving Water Monitoring Sites and Annual Frequency (wet/dry).....	18
Table 7. Annual Frequency of Receiving Water Monitoring for ULARWMAG Area Lakes	20
Table 8. Summary of Receiving Water Monitoring Program Objectives	23
Table 9. MS4 Database Elements Submitted with CIMP	24
Table 10. MS4 Database Elements to Be Developed	25
Table 11. Stormwater Outfall Monitoring Sites	29
Table 12. ULARWMAG Member Represented by Each Stormwater Outfall Monitoring Site...	30
Table 13. Land Use Summaries of Subwatersheds and Stormwater Outfall Monitoring Sites	33
Table 14. List of Parameters for Stormwater Outfall Monitoring	36
Table 15. Summary of Stormwater Outfall Monitoring Program Objectives	38
Table 16. Summary of the NSW Outfall Program Elements.....	41
Table 17. Approach for Establishing an Outfall Screening Process Utilizing <i>E. coli</i> Loading as the Key Characteristic for Determining Significant Non-Stormwater Discharges	43
Table 18. Summary of Endpoints for Source Identification.....	45
Table 19. List of NSW Outfall Monitoring Parameters.....	49
Table 20. Summary of NSW Outfall Monitoring Program Objectives	50
Table 21. Required Data to Track for New and Redevelopment Projects per Part X.A of the MRP	52
Table 22. Required Data to Track for New and Redevelopment Projects per Part VI.D.7.d.iv.(1)(a)	53

List of Attachments

Attachment A: Enhanced Watershed Management Plan Area Background

Attachment B: Monitoring Location Fact Sheets

Attachment C: Analytical and Monitoring Procedures

Attachment D: Data Management and Reporting

List of Appendices

- Appendix 1: Example Field, Calibration and Chain-of-Custody Forms
- Appendix 2: Trash Monitoring & Reporting Plan: Legg Lake Trash TMDL
- Appendix 3: Calculations for Data Quality Assessment
- Appendix 4: Chapter 13 QA/QC Data Evaluation from Caltrans Guidance Manual: Stormwater Monitoring Protocols, 2nd Edition

List of Acronyms

BMP	Best Management Practice
CERCLA	Comprehensive Environmental Response, Compensation, and Liability Act
CIMP	Coordinated Integrated Monitoring Program
CMP	Coordinated Monitoring Program
CVRWQCB	Central Valley Regional Water Quality Control Board
CWA	Clean Water Act
DAP	Discharge Assessment Plan
DCT	Donald C. Tillman
DDT	Dichloro-diphenyl-trichloroethane
DO	Dissolved Oxygen
EWMP	Enhanced Watershed Management Program
GIS	Geographic Information System
HRMS	High Resolution Mass Spectrometry
HUC	Hydrologic Unit Code
IC/ID	Illicit Connection/Illicit Discharge
LA	Los Angeles
LACDPW	Los Angeles County Department of Public Works
LACFCD	Los Angeles County Flood Control District
LAG	Los Angeles-Glendale
LAR	Los Angeles River
LLAR	Lower Los Angeles River
LRS	Load Reduction Strategy
LTA	Long Term Assessment
MRP	Monitoring and Reporting Program
MS4	Municipal Separate Storm Sewer System
NPDES	National Pollutant Discharge Elimination System

NSW	Non-Stormwater
OC	Organochlorine
PCB	Polychlorinated Biphenyl
RWL	Receiving Water Limitation
SCCWRP	Southern California Coastal Water Research Project
SMC	Stormwater Monitoring Coalition
SSC	Suspended Sediment Concentration
SW	Stormwater
TDS	Total Dissolved Solids
TIE	Toxicity Identification Evaluation
TKN	Total Kjeldahl Nitrogen
TMDL	Total Maximum Daily Load
TOC	Total Organic Carbon
TRE	Toxicity Reduction Evaluation
TSS	Total Suspended Solids
ULARWMAG	Upper Los Angeles River Watershed Management Area Group
USEPA	United States Environmental Protection Agency
WBPC	Waterbody-Pollutant Combination
WLA	Waste Load Allocation
WMA	Watershed Management Area
WPD	Watershed Protection Division
WQBEL	Water Quality Based Effluent Limitation
WRP	Water Reclamation Plant

1 Introduction

The National Pollutant Discharge Elimination System (NPDES) Municipal Separate Storm Sewer System (MS4) Permit No. R4-2012-0175 (Permit) was adopted November 8, 2012 by the Los Angeles Regional Water Quality Control Board (Regional Board) and became effective December 28, 2012. The purpose of the Permit is to ensure the MS4s in Los Angeles County are not causing or contributing to exceedances of water quality objectives set to protect the beneficial uses in the receiving waters. Included as Attachment E to the Permit are requirements for a Monitoring and Reporting Program (MRP). The stated Primary Objectives for the MRP, listed in Part II.A.1 of the MRP, are as follows:

1. Assess the chemical, physical, and biological impacts of discharges from the MS4 on receiving waters.
2. Assess compliance with receiving water limitations (RWLs) and water quality-based effluent limitations (WQBELs) established to implement Total Maximum Daily Load (TMDL) wet weather and dry weather wasteload allocations (WLAs).
3. Characterize pollutant loads in MS4 discharges.
4. Identify sources of pollutants in MS4 discharges.
5. Measure and improve the effectiveness of pollutant controls implemented under the Permit.

Permittees have the option to develop a Coordinated Integrated Monitoring Program (CIMP) to specify approaches for meeting the Primary Objectives of the MRP. The Upper Los Angeles River Watershed Management Area (WMA) Group (ULARWMAG) has selected to develop and implement a CIMP that is tailored to address the specific needs of the ULARWMAG Enhanced Watershed Management Program (EWMP) area. This CIMP provides a discussion of the monitoring locations, constituents, monitoring frequency, and general monitoring approach. The attachments and appendices to this CIMP describe additional background information and detail specific analytical and monitoring procedures that will be used to implement this CIMP. The ULARWMAG CIMP meets the requirements of the MS4 Permit, including all TMDL monitoring requirements.

1.1 ENHANCED WATERSHED MANAGEMENT PROGRAM AREA

The Los Angeles River (LAR or LA River) receives drainage from an 834-square mile area of central and eastern Los Angeles County and extends 55 miles across urbanized areas of the San Fernando and west San Gabriel Valleys. The LAR flows through residential, commercial, and industrial areas before becoming the LAR estuary, which empties into San Pedro Bay. **Figure 1** displays the ULARWMAG EWMP area which is comprised of 481 square miles¹, five of the six LA River reaches, numerous tributaries and the participating jurisdictions, which include the Cities of Alhambra, Burbank, Calabasas, Glendale, Hidden Hills, La Cañada Flintridge, Los Angeles, Montebello, Monterey Park, Pasadena, Rosemead, San Fernando, San Gabriel, San Marino, South El Monte, South Pasadena, and Temple City as well as unincorporated areas of

¹ Corresponds to total area of the ULARWMAG EWMP area (including non-urban open space). The total area considered in the EWMP (i.e., only using open space characterized as golf courses, local parks, and regional parks) is 377 square miles.

the County of Los Angeles and the Los Angeles County Flood Control District (LACFCD). A description of the LACFCD can be found in **Attachment A. Table 1** presents the major water bodies within the ULARWMAG EWMP area. Approximate land area and land use summaries for the participating jurisdictions are listed in **Table 3**, with the most prevalent land use being residential.

Table 1. Waterbodies Associated with the Upper Los Angeles River Watershed Management Area Group EWMP

Mainstem	Associated Tributaries	Downstream Waters
LA River Reach 6	Dry Canyon Creek McCoy Creek Bell Creek Aliso Canyon Wash	
LA River Reach 5	Bull Creek	
LA River Reach 4	Pacoima Wash Tujunga Wash	
LA River Reach 3	Burbank West Channel Verdugo Wash Arroyo Seco	
LA River Reach 2	Rio Hondo Reach 2	Rio Hondo Reach 1
	Compton Creek	LA River Reach 1
		LA River Estuary
		San Pedro Bay
Lakes		
Echo Park Lake	Legg Lake	Lake Calabasas

The TMDLs addressing water body-pollutant combinations (WBPCs) within or downstream of the EWMP area are presented in **Table 2**. Part XIX.B of the MRP, the TMDL Basin Plan Amendments (BPAs), and United States Environmental Protection Agency (USEPA)-established TMDL documents include TMDL monitoring requirements and recommendations, which are summarized in **Attachment A**.

Table 2. TMDLs Applicable to the Upper Los Angeles River Watershed EWMP

TMDL	Regional Board Resolution Number(s)	Effective Date and/or EPA Approval Date
LA River Nitrogen Compounds and Related Effects (LAR Nitrogen TMDL)	2003-009	03/23/2004
	2012-010	08/07/2014
Legg Lake Trash TMDL	2007-010	03/06/2008
Los Angeles River Trash TMDL	2007-012	09/23/2008
	2007-014	10/29/2008
Los Angeles River and Tributaries Metals TMDL (LAR Metals TMDL)	2010-003	11/03/2011
	2015-XXX	Not Yet Effective
Los Angeles River Bacteria TMDL (LAR Bacteria TMDL)	2010-007	03/23/2012
Dominguez Channel and Greater Los Angeles and Long Beach Harbor Waters Toxic Pollutants TMDL (Harbors Toxics TMDL)	2011-008	03/23/2012
Los Angeles Area Lakes TMDLs for Lake Calabasas, Echo Park Lake, and Legg Lake (Lakes TMDLs)	NA (USEPA TMDL)	03/26/2012

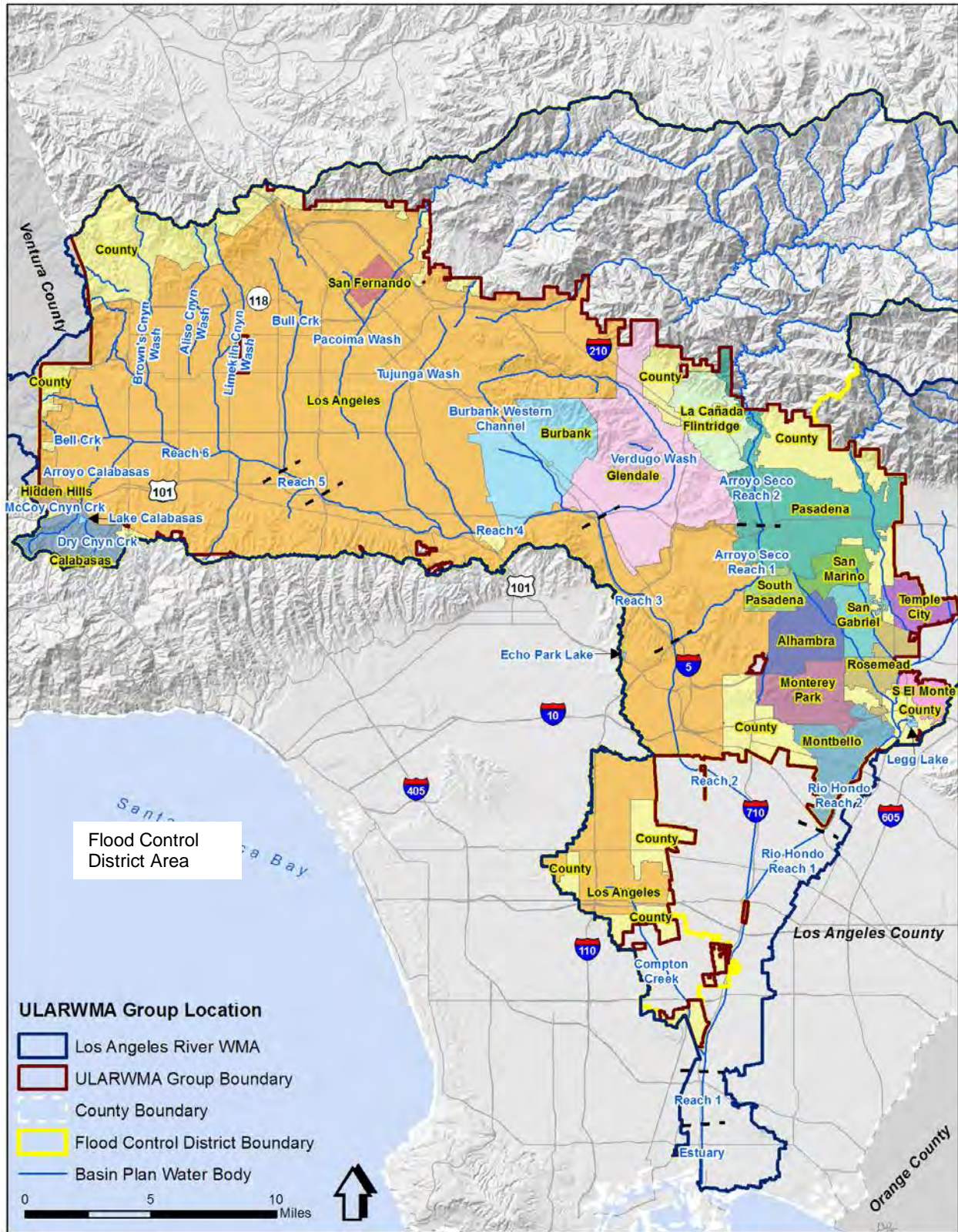

Figure 1. Upper Los Angeles River Watershed Management Area Group

Table 3. List of Jurisdictions Participating in the ULARWMAG with Land Use Summaries

Jurisdiction	Area (sq. mi.)	Percent of Jurisdiction ⁽¹⁾			
		Res	Com/Ind	Ag/Nur	Open
Alhambra	7.6	68.1%	28.0%	0.1%	3.8%
Burbank	12.7	63.3%	33.2%	0.1%	3.4%
Calabasas	3.3	73.4%	18.4%	0.5%	7.7%
County of Los Angeles	38.7	63.4%	26.5%	1.5%	8.6%
Glendale	18.4	69.0%	27.3%	0%	3.7%
Hidden Hills	1.3	98.9%	0%	1.1%	0%
La Canada Flintridge	6.4	77.8%	15.2%	0.9%	6.1%
Los Angeles	229.9	67.0%	27.9%	1.1%	4.0%
Montebello	7.9	48.9%	45.1%	1.5%	4.5%
Monterey Park	6.8	68.0%	27.3%	2.0%	2.7%
Pasadena	19.6	66.9%	27.0%	0.5%	5.6%
Rosemead	5.1	64.9%	29.5%	2.4%	3.2%
San Fernando	2.3	60.2%	38.2%	0.0%	1.6%
San Gabriel	4.1	70.2%	23.7%	1.7%	4.4%
South El Monte	2.5	33.2%	62.8%	0.6%	3.4%
San Marino	3.7	82.0%	10.4%	0.0%	7.6%
South Pasadena	3.2	80.7%	14.9%	0.3%	4.1%
Temple City	4.0	85.5%	13.6%	0.1%	0.8%
All Cities	377.4 ⁽²⁾	66.8%	27.6%	1.0%	4.5%

1. Land use classifications include: residential (Res), commercial and industrial (Com/Ind), agriculture and nursery (Ag/Nur), and open space (Open). Totals correspond to the percent of the total area considered in the EWMP (i.e., only using open space characterized as golf courses, local parks, and regional parks).
2. Only corresponds to the total area considered in the EWMP (i.e., only using open space characterized as golf courses, local parks, and regional parks). The total ULARWMAG EWMP area (including non-urban open space) is 481 square miles.

1.2 WATER QUALITY PRIORITIES

As part of the EWMP, the ULARWMAG analyzed data to determine water quality priorities for the watershed. While the water quality priorities analysis will be finalized as part of the EWMP development, an initial characterization of the water quality priorities has been developed and is briefly summarized in **Attachment A**. The three Permit categories are defined as:

- **Category 1:** WBPCs for which TMDL WQBELs and/or RWLs are established in Part VI.E and Attachments L and O of the MS4 Permit.
- **Category 2:** WBPCs for which data indicate water quality impairment in the receiving water according to the State’s Listing Policy, regardless of whether the pollutant is currently on the 303(d) List and for which the MS4 discharges may be causing or contributing.
- **Category 3:** WBPCs for which there are insufficient data to indicate impairment in the receiving water according to the State’s Listing Policy, but which exceed applicable

receiving water limitations contained in the MS4 Permit and for which MS4 discharges may be causing or contributing to the exceedance.

The Permit categories are utilized in this CIMP to identify parameters that will be monitored at each receiving water and outfall monitoring site. Since the analysis is waterbody specific, different parameters may be monitored at different monitoring sites. **Attachment A** contains a detailed discussion regarding the decision-making process for identifying parameters that will be monitored at each receiving water and outfall monitoring site.

1.3 CIMP OVERVIEW

The primary purpose of this CIMP is to outline the process for collecting data to meet the goals and requirements of the MRP. This CIMP is designed to provide the ULARWMAG the information necessary to guide water quality program management decisions. This CIMP provides information on sample collection and analysis methodologies. Additionally, the monitoring will provide a means to measure compliance with the Permit. The MRP, as outlined in the Permit, is composed of five elements, including:

1. Receiving Water Monitoring
2. Stormwater Outfall Monitoring
3. Non-Stormwater (NSW) Outfall Monitoring
4. New Development/Redevelopment Effectiveness Tracking
5. Regional Studies

In addition to the five elements, which are presented as sections in this CIMP, a specific trash monitoring section is included. An overview of each of the monitoring types and their monitoring objectives are described in the following subsections.

1.3.1 Receiving Water Monitoring

The objectives of the receiving water monitoring include the following:

- Determine whether the RWLs are being achieved;
- Assess trends in pollutant concentrations over time, or during specified conditions; and
- Determine whether the designated beneficial uses are fully supported as determined by water chemistry, as well as aquatic toxicity and bioassessment monitoring.

The receiving water monitoring will provide data to determine whether the RWLs and water quality objectives are being achieved in the ULARWMAG EWMP area and support management decisions related to EWMP implementation. Over time, the monitoring will allow the assessment of trends in pollutant concentrations. Receiving water monitoring consists of two long term assessment (LTA) monitoring stations designed to meet all receiving water permit requirements and additional TMDL monitoring locations necessary to evaluate TMDL requirements, 303(d) listings, and other exceedances of RWLs. Implementation of the ULARWMAG CIMP will replace existing TMDL monitoring programs.

1.3.2 Stormwater Outfall Monitoring

Stormwater outfall monitoring of discharges from the MS4 support meeting three objectives including:

- Determine the quality of stormwater discharge relative to municipal action levels.
- Determine whether stormwater discharge is in compliance with applicable stormwater WQBELs derived from TMDL WLAs.
- Determine whether the discharge causes or contributes to an exceedance of RWLs.

The stormwater outfall monitoring is designed to characterize stormwater discharges from MS4s at representative outfall locations within the EWMP area and support management decisions related to EWMP implementation. Additionally, implementation of the ULARWMAG CIMP will meet TMDL outfall monitoring requirements.

1.3.3 Non-Stormwater Outfall Program

The objectives of the NSW outfall monitoring include the following:

- Determine whether a discharge is in compliance with applicable NSW WQBELs derived from TMDL WLAs.
- Determine whether a discharge exceeds NSW action levels.
- Determine whether a discharge contributes to or causes an exceedance of RWLs.
- Assist in identifying illicit discharges.

The NSW Outfall Screening and Monitoring Program (NSW Outfall Program) is focused on dry weather discharges to receiving waters from major outfalls. The NSW Outfall Program provides monitoring to evaluate whether the NSW constituent load is adversely impacting the receiving water, serves to assess the Permit requirement to effectively prohibit NSW discharges, and serves to integrate with TMDL outfall monitoring efforts. These in turn support management decisions related to EWMP implementation.

1.3.4 New Development and Redevelopment Effectiveness Tracking

Permittees are required to maintain a database to track specific information related to new and redevelopment projects subject to the minimum control measure (MCM) requirements in Part VI.D.7. The Permit contains data tracking requirements in Part X.A of the MRP and in Part VI.D.7.d.iv. The objective of the New Development/Redevelopment effectiveness tracking is to track whether the conditions in the building permit issued by the Permittee are implemented to ensure the volume of stormwater associated with the design storm is retained on-site as required Part VI.D.7.c.i. of the Permit.

1.3.5 Trash Monitoring

The objective of the trash monitoring is to satisfy the monitoring requirements of the trash TMDLs for the LA River watershed, Echo Park Lake, and Legg Lake, in accordance with the requirement in Part III of the MRP.

1.3.6 Regional Studies

Only one regional study is identified in the MRP: Southern California Stormwater Monitoring Coalition (SMC). The Southern California SMC is a collaborative effort between all of the Phase I MS4 NPDES Permittees and NPDES regulatory agencies in Southern California. The Southern California Coastal Water Research Project (SCCWRP) oversees the SMC and the SMC is implemented by the Council for Watershed Health. The LACFCD and City of Los Angeles

will continue their participation in the SMC Regional Bioassessment Monitoring Program on behalf of the ULARWMAG to meet this MRP requirement.

2 Receiving Water Monitoring Program

The objectives of the receiving water monitoring (Part I.I.E.1 of the MRP) include the following:

- a. Determine whether the receiving water limitations are being achieved;
- b. Assess trends in pollutant concentrations over time, or during specified conditions; and
- c. Determine whether the designated beneficial uses are fully supported as determined by water chemistry, as well as aquatic toxicity and bioassessment monitoring.

The following presents the receiving water monitoring sites, monitoring parameters and frequency, as well as a discussion on monitoring coordination and summary of how the receiving water monitoring program meets the objectives of the MRP. The approach builds off the MRP requirements, the TMDL monitoring requirements (detailed in **Attachment A**), as well as existing monitoring programs in the watershed (detailed in **Attachment A**). Implementation of the ULARWMAG CIMP will fulfill existing TMDL monitoring program requirements and meet the monitoring requirements for TMDLs that had not yet implemented monitoring programs (e.g., Harbors Toxics TMDL). Note that the Harbors Toxics TMDL required the development of a monitoring program and quality assurance project plan (QAPP). This CIMP addresses those requirements. While not all aspects of a QAPP are explicitly addressed herein, the primary requirements that are not included relate to the implementation of the CIMP (e.g., definition of project manager, lines of communication, and standard operating procedures). These requirements will be addressed once implementation of the CIMP begins.

2.1 RECEIVING WATER MONITORING SITES

The MRP specifies that receiving water monitoring shall be performed at previously designated mass emission stations (unless justification of why monitoring at the mass emission stations will be discontinued is provided), TMDL receiving water compliance points (as designated in TMDL Monitoring Plans approved by the Regional Board Executive Officer), and additional receiving water locations representative of the impacts from MS4 discharges. To address the different monitoring objectives, two types of monitoring sites are included in this CIMP.

- **LTA Receiving Water** – LTA receiving water monitoring is intended to determine if RWLs are achieved, assess trends in pollutant concentrations over time, and determine whether designated uses are supported.
- **TMDL Receiving Water** – TMDL receiving water monitoring is intended to evaluate attainment of, or progress in attaining TMDLs, and support evaluating the status of 303(d) listings and other RWL exceedances in the watershed.

LTA monitoring provides a long-term record to understand conditions within the EWMP area, for the full suite of parameters, including TMDL parameters. TMDL monitoring addresses TMDL related constituents and provides monitoring locations to assess other identified exceedances of RWLs determined through an analysis of existing and future data.

Monitoring similar to LTA monitoring was required on the mainstem of the Los Angeles River by the previous MS4 Permit, but this monitoring was conducted downstream of the ULARWMAG area. TMDL monitoring has been ongoing for some time in the ULARWMAG area. Within the ULARWMG area, TMDL monitoring sites were required on the following

waterbodies: Los Angeles River Reaches 2 through 6, Compton Creek, Rio Hondo, Arroyo Seco, Verdugo Wash, Burbank Western Channel, Tujunga Wash, Bull Creek, Aliso Canyon Wash, McCoy Canyon Creek, Dry Canyon Creek, Bell Creek, Legg Lake, Echo Park Lake, and Lake Calabasas. To meet the TMDL requirements, four Coordinated Monitoring Programs (CMPs) were developed and were considered during CIMP site selection:

- *Los Angeles River Metals TMDL Coordinated Monitoring Plan* (Metals TMDL CMP)
- *DRAFT Coordinated Monitoring Plan for Los Angeles River Watershed Bacteria TMDL – Compliance Monitoring* (Bacteria TMDL CMP)
- *Monitoring Work Plan to Assess Nutrients Loading from the Municipal Separate Storm Sewer System in Los Angeles River Watershed* (Nitrogen TMDL CMP)
- *Trash Monitoring & Reporting Plan: Legg Lake Trash TMDL*

The receiving water monitoring sites in the ULARWMAG EWMP area and the type of monitoring (e.g., LTA or TMDL) that will be conducted at each site are summarized in **Table 4**. The locations of the monitoring sites are shown in **Figure 2**. Each constituent required for monitoring by the MRP is addressed by at least one of the two types of receiving water monitoring. A summary of constituents which will be monitored at each of the receiving water monitoring sites is presented in **Section 2.2**.

The receiving water monitoring sites meet the MRP objectives and support an understanding of potential impacts associated with MS4 discharges. However, as described in the MRP (Part II.E.1), receiving water sites are intended to assess receiving water conditions. An exceedance of a RWL at a receiving water site may not on its own indicate MS4 discharges caused or contributed to the RWL exceedance. As the receiving water sites also receive runoff from non-MS4 sources, including open space and other permitted discharges, the exceedance of a RWL may have been caused or contributed to by a non-MS4 source. A determination regarding whether MS4 discharges caused or contributed to a RWL exceedance should be made using receiving water monitoring data, representative outfall monitoring data, and other pertinent data and information.

Table 4. Receiving Water Monitoring Sites

Site ID	Waterbody/Location	Previous Site Name Used in TMDL Monitoring Programs	Coordinates		Monitoring Type	
			Latitude	Longitude	LTA	TMDL
LAR_02_WAS	LA River Reach 2 upstream of Washington Blvd	LAR1-8	34.018436	-118.223499	X	X
LAR_03_FIG	LA River Reach 3 at Figueroa St	LAR1-7; LARB-03	34.081249	-118.227546		X
LAR_03_ZOO ⁽¹⁾	LA River Reach 3 at Zoo Dr	LAR1-6	34.155683	-118.281270		X
LAR_04_TUJ	LA River Reach 4 at Tujunga Ave	LAR1-4; LARB-04	34.140977	-118.379127	X	X
LAR_05_SEP ⁽²⁾	LA River Reach 5 at Sepulveda Blvd	LAR1-2	34.161559	-118.465969		X
LAR_06_WHI	LA River Reach 6 at White Oak Ave	LAR1-1	34.185076	-118.518735		X
CC_ELS	Compton Creek upstream of El Segundo Blvd	N/A	33.917332	-118.249956		X
RH_SLA	Rio Hondo at Slauson Ave	N/A	33.975272	-118.118805		X
AS_SAN	Arroyo Seco at San Fernando Rd	LAR2-3; LARB-08	34.080470	-118.224970		X
VW_CON	Verdugo Wash at Concord St	LAR2-2; LARB-09	34.156724	-118.271240		X
BWC_RIV ⁽³⁾	Burbank Western Channel at Riverside Dr	LAR1-5; LARB-10	34.160714	-118.305020		X
TW_MOO	Tujunga Wash at Moorpark St	LAR1-3; LARB-11	34.151206	-118.395564		X
BUL_VIC ⁽⁴⁾	Bull Creek at Victory Blvd	LARB-12	34.186770	-118.497780		X
ACW_VAN	Aliso Canyon Wash at Vanowen St	LARB-13	34.193615	-118.543966		X
MCC_VAL	McCoy Canyon Creek at Valley Circle Blvd	LARB-14	34.163094	-118.637946		X
DCC_VEN	Dry Canyon Creek at Ventura Blvd	LARB-15	34.161533	-118.634355		X
BEL_FAL	Bell Creek at Fallbrook Ave	LARB-16	34.197489	-118.623553		X
EPL_1	Echo Park Lake	N/A	34.073056	-118.260783		X
EPL_2			34.071242	-118.260734		X
LEG_LAK	Legg Lake	N/A	Varies	Varies		X
CAL_LAK	Lake Calabazas	N/A	Varies	Varies		X

1. For improved coordination, this site could be moved to Colorado Blvd co-located with a site currently monitored by the LA-Glendale (LAG) Water Reclamation Plant (WRP).
2. For improved coordination, this site could be moved to be co-located with a site currently being monitored by the Donald C. Tillman (DCT) WRP.
3. For improved coordination, this site could be moved to be co-located with a site currently being monitored by the Burbank WRP.
4. For improved coordination, this site is co-located with a receiving water site currently being monitored by the DCT WRP.

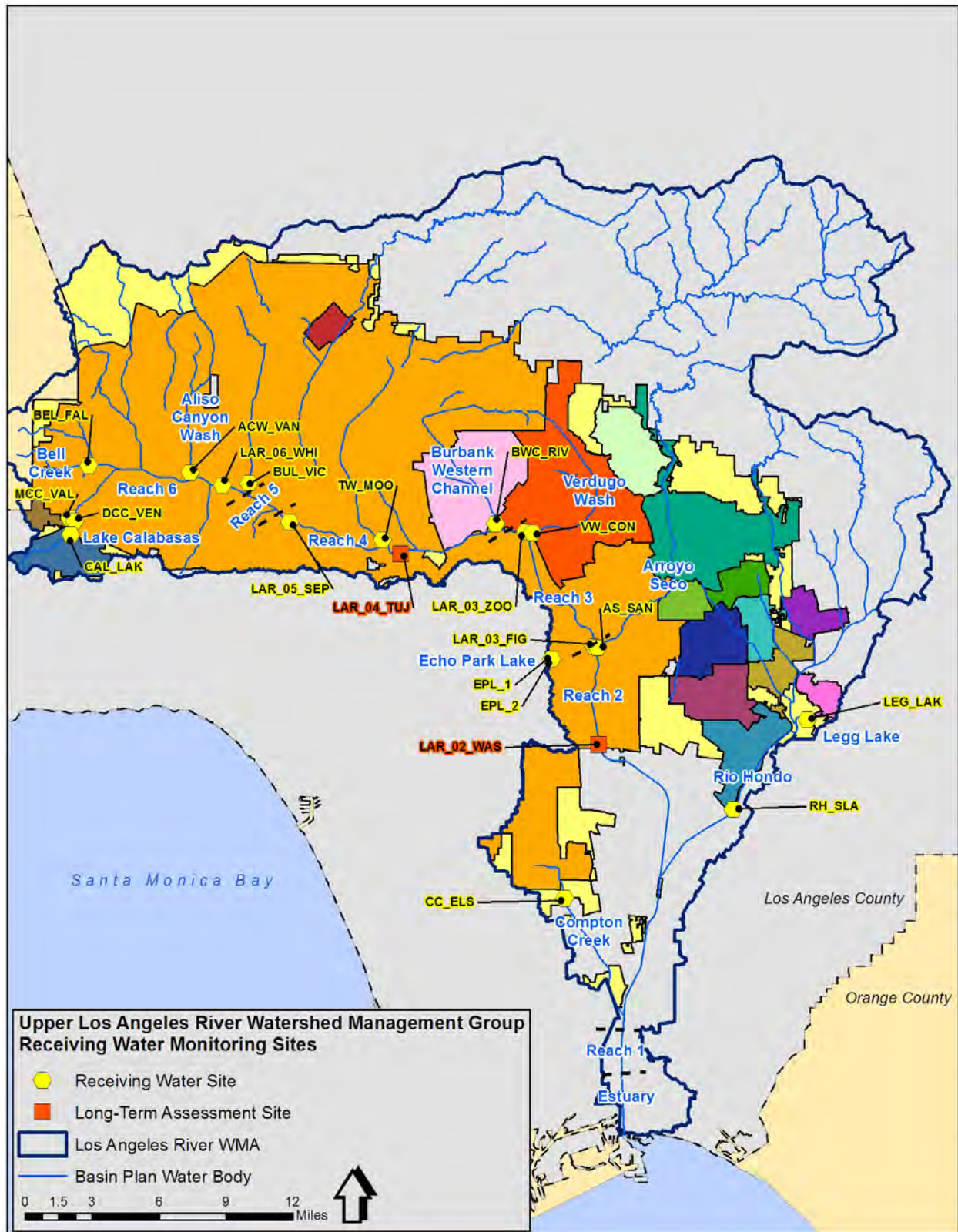

Figure 2. Overview of Receiving Water Monitoring Sites

2.1.1 Long Term Assessment Monitoring Sites

One of the primary objectives of receiving water monitoring is to assess trends in pollutant concentrations over time, or during specified conditions. As a result, the primary characteristic of an ideal receiving water assessment monitoring site is a robust dataset of previously collected monitoring results so that trends in pollutant concentrations over time, or during specified conditions, can be assessed. Such a site does not exist within the ULARWMAG area. Therefore, two new LTA sites are proposed to support an understanding of potential impacts associated with MS4 discharges from the ULARWMAG.

The LAR at Washington Blvd is the location of a site for the Metals TMDL CMP and the intersection of the Los Angeles River with the downstream boundary of the ULARWMAG area. Locating a site at Washington Blvd will provide a long historical record by which to assess trends over time and evaluate the long-term attainment of RWLs and beneficial uses within the downstream portion of the EWMP area. The LAR at Tujunga Ave is the location of a site for the Metals TMDL CMP and the Bacteria TMDL CMP. Locating a site at Tujunga Ave will also provide a long historical record by which to assess trends over time and evaluate the long-term attainment of RWLs and beneficial uses within the upstream portion of the EWMP area. These sites will also be utilized to support TMDL monitoring. The location of the LTA monitoring sites can be seen on **Figure 2. Attachment B** provides a summary of the monitoring sites, associated attributes, and photographs.

Another primary role of the LTA sites is to identify additional constituents for monitoring at other locations within the watershed. If exceedances are observed at the LTA sites as described in **Section 2.2** monitoring for those constituents will be added to upstream TMDL sites.

2.1.2 TMDL Sites

Within the ULARWMAG EWMP area, TMDL monitoring sites are required in Los Angeles River Reaches 2 through 6, Compton Creek, Rio Hondo, Arroyo Seco, Verdugo Wash, Burbank Western Channel, Tujunga Wash, Bull Creek, Aliso Canyon Wash, McCoy Canyon Creek, Dry Canyon Creek, Bell Creek, Legg Lake, Echo Park Lake, and Lake Calabasas. Twenty-one TMDL sites will be monitored under this CIMP. The following briefly describes how existing TMDL monitoring sites are incorporated into this CIMP. Note that upon approval by the Regional Board Executive Officer, the CIMP will effectively replace the existing CMPs.

The eight Tier I water quality monitoring sites currently monitored as part of the Metals TMDL CMP (LAR1-X sites in **Table 4**) which are located within the ULARWMAG EWMP area will be used as TMDL monitoring sites. In addition, two Tier II water quality monitoring sites included in the Metals TMDL CMP (Arroyo Seco and Verdugo Wash designated as LAR2-X sites in **Table 4**) will be used as TMDL monitoring sites. The one Tier II water quality monitoring site included in the Metals TMDL CMP which is not a TMDL monitoring site is LAR2-1 located on Reach 6 of the LA River. LAR2-1 was a Tier II site intended to be triggered based on the criteria in the CMP (two consecutive exceedances during the same condition at the downstream Tier I site). LAR2-1 was only triggered during dry weather for selenium due to exceedances of the TMDL target at the tier 1 site on Reach 6 (LAR_06_WHI formally LAR1-1). No other TMDL constituent triggered dry weather monitoring (copper exceeded the dissolved and total TMDL targets 0 out of 38 samples and 1 out of 31 samples and total lead had 0

exceedances out of 31 samples). Selenium was sampled at LAR2-1 seven times between June 2012 and June 2013 (which is the end of the period of record for CIMP development). As described in the Metals TMDL selenium is considered to be naturally occurring and, because of this, only load allocations were developed (and not assigned to a particular non-point source) and MS4s were not assigned a wasteload allocation. For wet weather, LAR2-1 was triggered for copper and zinc by exceedances of the TMDL targets at the tier 1 site on Reach 6 (LAR_06_WHI formally LAR1-1). The one wet weather sample at LAR2-1 did not exceed TMDL targets (results were between 2.5 to 7.5 times lower than the TMDL targets for copper and zinc, respectively, while lead was 42 times lower than the TMDL target). Because the historical data for Reach 6 indicates that only selenium is exceeded during dry weather and the source is considered to be from non-point sources and the TMDL constituents were not observed to be exceeding during wet weather, the LAR2-1 was not included in the CIMP.

The 12 sites included in the Bacteria TMDL CMP (LARB-XX sites in **Table 4**) located within the ULARWMAG EWMP area will also be TMDL monitoring sites, with one exception for improved coordination. The LARB-05 monitoring site has been moved to the location of the Metals TMDL CMP monitoring site located in LAR Reach 6 (LAR_06_WHI formally LAR1-1). The LAR Bacteria TMDL requires a monitoring site in each reach and segment of the mainstem of the LAR. The CIMP meets this requirement for Reach 6/Segment E by utilizing LAR_06_WHI. The LARB-05 monitoring site was originally suggested to meet the requirement for Segment E, but was replaced by LAR-06_WHI as that is the historical and current location for Metals TMDL monitoring. Rather than have two separate dry weather sites (one for metals and one for bacteria), LAR-06-WHI can be used for both.

In addition to these 12 sites, the LARB-02 (LAR Reach 2), LARB-06 (Compton Creek), and LARB-07 (Rio Hondo) monitoring sites have been moved to locations within the ULARWMAG EWMP area as follows:

- LAR Reach 2: LARB-02 moved from Rosecrans Avenue to Washington Boulevard and renamed LAR_02_WAS
- Compton Creek: LARB-06 moved from just upstream of the confluence with the LAR to upstream of El Segundo Blvd and renamed CC_ELS
- Rio Hondo: LARB-07 moved from just upstream of the confluence with the LAR to Slauson Avenue and renamed CC_ELS.

Additionally, bacteria monitoring will also occur in LAR Reach 5 at Sepulveda Boulevard (LAR_05_SEP) for a total of 16 monitoring sites utilized to meet the Bacteria TMDL monitoring requirements.

The site included in the Nitrogen TMDL CMP is not included because it is located downstream of the ULARWMAG EWMP area, but nutrient related monitoring will occur at the downstream boundary of the ULARWMAG EWMP area (the LAR_02_WAS LTA site) as part of this CIMP.

TMDL monitoring sites are also located in Legg Lake, Echo Park Lake, and Lake Calabajas. The Echo Park Lake sites are based on an existing program, whereas the Legg Lake and Lake Calabajas sites were added to ensure the TMDL monitoring requirements were fulfilled. The

TMDL monitoring sites are listed in **Table 4** and shown on **Figure 2**. **Attachment B** provides a summary of the monitoring sites, associated attributes, and photographs.

2.2 MONITORED PARAMETERS AND FREQUENCY OF MONITORING

Each constituent required for monitoring by the MRP is addressed by at least one of the two types of receiving water monitoring (LTA or TMDL). Constituents for monitoring were based on the water quality priorities. **Section 3** of **Attachment A** contains a detailed discussion regarding the decision-making process for identifying parameters that will be monitored at each receiving water site. A summary of constituents which will be monitored at each of the LA River mainstem receiving water monitoring sites is presented in **Table 5**. A summary of constituents which will be monitored at each of the LA River tributary receiving water monitoring sites is presented in **Table 6**. A summary of constituents which will be monitored at each lake receiving water monitoring site is presented in **Table 7**. These lists reflect the water quality priorities because all Category 1, 2, and 3 water quality priorities will be monitored as part of this CIMP, except as detailed in **Section 3** of **Attachment A**. Analytical methods, detection limits, sampling methods, and sample handling procedures are detailed in **Attachment C**. In addition, details regarding the collection of quality assurance/quality control (QA/QC) samples are outlined in **Attachment C**.

As described in **Section 11**, data collected as part of the ULARWMAG CIMP will be reviewed and changes to the constituents and frequencies listed in **Table 5**, **Table 6**, and **Table 7** will be discussed in the annual report and implemented starting no later than the first CIMP event of the next monitoring year (i.e., the first event after July 1 of the year following the annual report submittal). Data collected at the LTA sites will be used to identify additional constituents for monitoring at other locations within the watershed. The LAR_02_WAS LTA site will be used to identify additional constituents for monitoring at LAR Reach 3 monitoring sites. The LAR_04_TUJ LTA site will be used to identify additional constituents for monitoring at LAR Reaches 5 and 6 monitoring sites. Except for constituents for which a TMDL has been established and interim compliance milestone dates have not passed², monitoring for a new constituent would be initiated at upstream receiving water monitoring sites if there are two consecutive exceedances³ observed during the same condition (i.e., wet or dry weather) at the associated downstream LTA site and would continue until the deactivation criterion is triggered. The deactivation criterion is two consecutive samples that do not exceed RWLs during the same condition (i.e., wet or dry weather). The same activation/deactivation criteria were utilized in the LA River Metals CMP. The two consecutive exceedance/non-exceedance activation/deactivation criteria are used to avoid the possibility of performing additional sampling to compensate for one-time events that may be a result of sampling and/or analytical error.

² For example, the LAR Bacteria TMDL schedule required a wet weather implementation plan be submitted 10 years after the effective date of the TMDL (April 2022), with final compliance due 25 years after the effective date (April 2037). Given the timeframe for implementation and the significant amount of implementation that will occur prior to the first TMDL milestone (10 years), collection of bacteria data during wet weather throughout the ULAR EWMP area at this time will not provide meaningful information upon which to make management decisions. As such, wet weather monitoring related to the LAR Bacteria TMDL will be conducted at the downstream boundary of the ULAR EWMP area to assess trends over time, but in no other locations at this time. The need for such information will be evaluated during EWMP and CIMP implementation and will be added in the future.

³ Monitoring data which shows that a constituent is meeting an interim compliance milestones will not be considered an exceedance.

Table 5. Summary of Parameters to be Monitored at Receiving Water Monitoring Sites and Annual Frequency (wet/dry)⁽¹⁾

Parameters	Los Angeles River Reaches					
	2	3 (below LAG WRP)	3 (above LAG WRP)	4	5	6
Site ID	LAR_02_WAS	LAR_03_FIG	LAR_03_ZOO	LAR_04_TUJ	LAR_05_SEP	LAR_06_WHI
Flow and field parameters ⁽²⁾	Frequency is equal to the number of times a site is visited for monitoring					
Pollutants identified in Table E-2 of the MRP ⁽³⁾ and not otherwise addressed below	1 ⁽⁴⁾ /1 ⁽⁴⁾			1 ⁽⁴⁾ /1 ⁽⁴⁾		
Aquatic Toxicity and Toxicity Identification Evaluation (TIE), if necessary	2/1			2/1		
<i>E. Coli</i>	3/12	0/12 ⁽⁵⁾		3/12 ⁽⁵⁾	0/12 ⁽⁵⁾	0/12
Hardness ⁽⁶⁾	3/4	3/4	0/4	3/4	0/4	3/4
Total Suspended Sediment (TSS)	Frequency is equal to the number of times a site is visited for monitoring					
Cadmium (total and dissolved)	3/0					
Copper (total and dissolved) ⁽⁶⁾	3/4	3/4	0/4	3/4	0/4	3/4
Lead (total and dissolved) ⁽⁶⁾	3/4	3/4	0/4	3/4	0/4	3/4
Selenium (total) ⁽⁶⁾						0/4
Zinc (total and dissolved) ⁽⁶⁾	3/4	3/4	0/4	3/4	0/4	3/4
Mercury (total)	3/2	3/2 ⁽⁵⁾	0/2 ⁽⁵⁾	3/2 ⁽⁵⁾	0/2 ⁽⁵⁾	3/2
Suspended Sediment: Copper, Lead, Zinc, Chlordane ⁽⁷⁾ , DDT ⁽⁸⁾ , PCBs ⁽⁹⁾ , PAHs ⁽¹⁰⁾ , and Suspended Sediment Concentration (SSC)	2/1 ⁽⁵⁾					
Ammonia as N, Nitrate as N, Nitrite as N, Nitrate+Nitrite, Nitrogen (NO3-N+NO2-N)	3/2	0/2 ⁽⁵⁾	0/2 ⁽⁵⁾	3/2 ⁽⁵⁾	0/2 ⁽⁵⁾	
2,3,7,8-TCDD (Dioxin)		0/2 ⁽⁵⁾				0/2 ⁽⁵⁾
Diazinon				0/2 ⁽⁵⁾	0/2 ⁽⁵⁾	
DDT ⁽⁸⁾					0/2 ⁽⁵⁾	
Chloride					0/2 ⁽⁵⁾	0/2 ⁽⁵⁾
Sulfate				0/2 ⁽⁵⁾	0/2 ⁽⁵⁾	0/2 ⁽⁵⁾
TDS					0/2 ⁽⁵⁾	0/2 ⁽⁵⁾

1. Annual frequency listed as number of wet/dry-weather events per year, respectively (e.g., 3/2 signifies three wet and two dry weather events per year).
2. Field parameters are defined as DO, pH, temperature, and specific conductivity.
3. All pollutants identified in Table E-2 of the MRP not already explicitly addressed by monitoring at this site.

4. Monitoring frequency only applies during the first year of monitoring. For constituents identified in Table E-2 of the MRP that are not detected at the Method Detection Limit (MDL) or the result is below the lowest applicable water quality objective, additional monitoring will not be conducted (i.e., the monitoring frequency will become 0/0). For constituents detected above the lowest applicable water quality objective, future monitoring will be conducted at the frequency specified in the MRP (i.e., the monitoring frequency will become 3/2).
5. Data to be obtained through non-direct measurements as described in **Section 10**.
6. Monitoring sites monitored quarterly during dry weather (i.e., annual frequency is listed as X/4) for monitoring related to the Metals TMDL, will be monitored monthly (i.e., annual frequency will become X/9) if there are two consecutive exceedances observed during dry weather at the monitoring site and would continue until the deactivation criterion is triggered. The deactivation criterion is two consecutive samples that do not exceed RWLs during dry weather. The same activation/deactivation criteria were utilized in the LA River Metals CMP.
7. As outlined in **Attachment D**, chlordane includes analyses for the following species: alpha-chlordane, gamma-chlordane, oxychlordane, cis-Nonachlor, and trans-Nonachlor.
8. DDT includes analyses for the following species: 2,4'-DDD, 2,4'-DDE, 2,4'-DDT, 4,4'-DDD, 4,4'-DDE, and 4,4'-DDT.
9. As outlined in **Attachment D**, PCBs includes analyses for all aroclor species when analyzed in water and the following 54 PCB congeners when analyzed in water or suspended solids: 8, 18, 28, 31, 33, 37, 44, 49, 52, 56, 60, 66, 70, 74, 77, 81, 87, 95, 97, 99, 101, 105, 110, 114, 118, 119, 123, 126, 128, 132, 138, 141, 149, 151, 153, 156, 157, 158, 167, 168, 169, 170, 174, 177, 180, 183, 187, 189, 194, 195, 201, 203, 206, and 209. Analyses will be conducted for 54 PCB congeners when analyzed in water because these congeners are necessary for calculating total PCBs when evaluating water concentrations for the purposes of comparing to the California Toxics Rule human health criteria. Suspended solids will be analyzed utilizing High Resolution Mass Spectrometry (HRMS) on whole water samples; therefore, analyses will also be conducted for 54 PCB congeners when analyzed in suspended solids.
10. As outlined in **Attachment D**, PAHs includes analyses for the following species: acenaphthene, anthracene, biphenyl, naphthalene, 2,6-dimethylnaphthalene, fluorene, 1-methylnaphthalene, 2-methylnaphthalene, 1-methylphenanthrene, phenanthrene, benzo(a)anthracene, benzo(a)pyrene, benzo(e)pyrene, chrysene, dibenz(a,h)anthracene, fluoranthene, perylene, and pyrene.

Table 6. Summary of Constituents to be Monitored at ULARWMAG Los Angeles River Tributary Receiving Water Monitoring Sites and Annual Frequency (wet/dry)⁽¹⁾

Constituents	Compton Creek	Rio Hondo	Arroyo Seco	Verdugo Wash	Burbank Western Channel	Tujunga Wash	Bell Creek	Bull Creek	Aliso Canyon Wash	McCoy Canyon Creek	Dry Canyon Creek
Site ID	CC_ELS	RH_SLA	AS_SAN	VW_CON	BWC_RIV	TW_MOO	BEL_FAL	BUL_VIC	ACW_VAN	MCC_VAL	DCC_VEN
Flow and field parameters ⁽²⁾	Frequency is equal to the number of times a site is visited for monitoring										
TSS	Frequency is equal to the number of times a site is visited for monitoring										
Aquatic Toxicity and TIE, if necessary		2/1									
<i>E. Coli</i>	0/12	0/12	0/12	0/12	0/12	0/12	0/12	0/12	0/12	0/12	0/12
Hardness ⁽³⁾	0/4	0/9			0/4	0/9					
Copper (total and dissolved) ⁽³⁾	0/4	0/9			0/4	0/9					
Lead (total and dissolved) ⁽³⁾	0/4	0/9			0/4	0/4					
Zinc (total and dissolved) ⁽³⁾	0/4	0/4			0/4	0/4					
Bis(2-ethylhexyl) Phthalate		0/2 ⁽⁴⁾	0/2		0/2			0/2	0/2		
2,3,7,8-TCDD (Dioxin)					0/2 ⁽⁴⁾						
Chlorpyrifos	0/2										
Diazinon		0/2 ⁽⁴⁾							0/2		
Chloride	0/2	0/2 ⁽⁴⁾			0/2 ⁽⁴⁾	0/2					
Sulfate									0/2		
TDS					0/2 ⁽⁴⁾	0/2			0/2		
Cyanide (total)		0/2 ⁽⁴⁾									
Chrysene		0/2 ⁽⁴⁾									
Dibenzo(a,h) Anthracene		0/2 ⁽⁴⁾									
Indeno (1,2,3-cd)Pyrene		0/2 ⁽⁴⁾									
Benzo(a)Pyrene		0/2 ⁽⁴⁾			0/2 ⁽⁴⁾						
Benzo(b) Fluoranthene		0/2 ⁽⁴⁾			0/2 ⁽⁴⁾						

1. Annual frequency listed as number of wet-weather/dry-weather events per year, respectively (e.g., 3/2 signifies three wet weather and two dry weather events per year).

2. Field parameters are defined as DO, pH, temperature, and specific conductivity. Flow and field parameters will not be monitored when *E. coli* is the only constituent monitored at a site.
3. Monitoring sites monitored quarterly during dry weather (i.e., annual frequency is listed as X/4) for monitoring related to the Metals TMDL, will be monitored monthly (i.e., annual frequency will become X/9) if there are two consecutive exceedances observed during dry weather at the monitoring site and would continue until the deactivation criterion is triggered. The deactivation criterion is two consecutive samples that do not exceed RWLs during dry weather. The same activation/deactivation criteria were utilized in the LA River Metals CMP.
4. Data to be obtained through non-direct measurements as described in **Section 10**.

Table 7. Annual Frequency of Receiving Water Monitoring for ULARWMAG Area Lakes

Constituent	Calabasas Nutrient TMDL	Echo Park Lake Nutrient, Trash, PCBs, and OC Pesticide TMDLs	Legg Lake Nutrient TMDL & Legg Lake Trash TMDL
In-lake Water Quality Monitoring			
TSS, TDS, Temperature, Dissolved Oxygen, pH, Electrical Conductivity, and Secchi Depth	2/summer 1/winter	2/summer 1/winter	2/summer 1/winter
Ammonia, TKN or Organic N, Nitrate+Nitrite, Orthophosphate, Total Phosphorus, Chlorophyll a	2/summer 1/winter	2/summer 1/winter	2/summer 1/winter
Total PCBs ⁽¹⁾ , Total Chlordane ⁽²⁾ , Dieldrin		1/winter	
Sediment Quality Monitoring			
Total Organic Carbon, Total PCB ⁽³⁾ , Total Chlordane ⁽²⁾ , Dieldrin		1/winter	
Fish Tissue Monitoring⁽⁴⁾			
Total PCB ⁽⁵⁾ , Total Chlordane ⁽²⁾ , Dieldrin		Once every three years	
Trash Monitoring			
Trash Quantity			Monthly

- As outlined in **Attachment D**, PCBs includes analyses for all aroclor species and the following 54 PCB congeners when analyzed in water: 8, 18, 28, 31, 33, 37, 44, 49, 52, 56, 60, 66, 70, 74, 77, 81, 87, 95, 97, 99, 101, 105, 110, 114, 118, 119, 123, 126, 128, 132, 138, 141, 149, 151, 153, 156, 157, 158, 167, 168, 169, 170, 174, 177, 180, 183, 187, 189, 194, 195, 201, 203, 206, and 209. Analyses will be conducted for 54 PCB congeners when analyzed in water because these congeners are necessary for calculating total PCBs when evaluating water concentrations for the purposes of comparing to the California Toxics Rule human health criteria.
- As outlined in **Attachment D**, chlordane includes analyses for the following species: alpha-chlordane, gamma-chlordane, oxychlordane, cis-Nonachlor, and trans-Nonachlor.
- As outlined in **Attachment D**, PCBs includes analyses for the following 19 congeners when analyzed in sediment: 8, 18, 28, 44, 52, 66, 101, 105, 118, 128, 138, 153, 170, 180, 187, 189, 195, 206, and 209. Analyses will be conducted for 19 PCB congeners when analyzed in sediment because these congeners are necessary for calculating total PCBs when evaluating sediment concentrations associated with the direct effects California Sediment Quality Objectives.
- Composite sample of skin-off fillets from at least five common carp > 350 mm in length.
- As outlined in **Attachment D**, PCBs includes analyses for the following 41 congeners when analyzed in tissue: 18, 28, 37, 44, 49, 52, 66, 70, 74, 77, 81, 87, 99, 101, 105, 110, 114, 118, 119, 123, 126, 128, 138, 149, 151, 153, 156, 157, 158, 167, 168, 169, 170, 177, 180, 183, 187, 189, 194, 201, and 206. Analyses will be conducted for 41 PCB congeners when analyzed in fish tissue because these congeners are necessary for calculating total PCBs when evaluating tissue samples associated with indirect effects.

2.3 WEATHER CONDITIONS

Monitoring will occur during dry and wet conditions. Dry weather is defined in the MRP as when the flow of the receiving waterbody is less than 20 percent greater than the base flow or, in the case of an estuary, on days with less than 0.1 inch of rain and those days not less than three days after a rain event of 0.1 inch or greater within the watershed, as measured from at least 50 percent of Los Angeles County Department of Public Works (LACDPW) controlled rain gauges within the watershed. Wet weather conditions are defined in the MRP as when the receiving waterbody has flow that is at least 20 percent greater than its base flow or, in the case of an estuary, during a storm event of greater than or equal to 0.1 inch of precipitation. The LA River Metals TMDL defines wet weather as when the maximum daily flow rate is equal to or greater than 500 cubic feet per second (cfs) and dry weather as below 500 cfs at LACDPW Wardlow Road flow gauge and the LAR Bacteria TMDL defines wet weather as days with 0.1 inch of rain or greater and the three days following the rain event. As such, for the purposes of this CIMP, weather conditions will be defined as follows:

- **Dry Weather:** When the flow of the receiving water body is less than 500 cfs at LACDPW Wardlow Road flow gauge or an equivalent flow rate at the monitoring site⁴ **and** there is less than 0.1 inch of rain on that day and in the previous three days.
- **Wet Weather:** When the flow of the receiving water body is equal to or greater than 500 cfs at LACDPW Wardlow Road flow gauge or an equivalent flow rate at the monitoring site⁵ **and** there is at least 0.1 inch of rain during the targeted storm event.

Note that if rainfall begins after dry weather monitoring has been initiated, then dry weather monitoring will be suspended and continued on a subsequent day when weather conditions meet the dry weather conditions. Generally, grab samples will be collected during dry weather and composite samples will be collected during wet weather. Grab samples will be used for dry weather sampling events because the composition of the receiving water will change less over time; and thus, the grab sample can sufficiently characterize the receiving water. Grab samples during dry weather are consistent with similar programs within the region. However, to sufficiently characterize the receiving water during wet weather, composite samples will generally be used for wet weather sampling events. Grab samples may be utilized to collect wet weather sampling in certain situations, which may include, but are not limited to, when the constituent of interest requires the use of grab samples (e.g., *E. coli* and oil and grease), situations where it is unsafe to collect composite samples, or to perform investigative monitoring where composite sampling or installation of an automatic sample compositor (autosampler) may not be warranted. For safety purposes, when wet weather grab sampling is conducted, samples may be taken from slightly upstream or downstream of the designated monitoring location.

The MRP includes specific criteria for the time of monitoring events. With the exception of bacteria and metals monitoring, most constituents will be monitored during two dry weather monitoring events. For dry weather toxicity monitoring, sampling must take place during the month with the historically lowest flows. As a result, the dry weather monitoring event that

⁴ The wet weather flow trigger for an individual receiving water monitoring location will be set at an appropriate value given where the monitoring location is situated within the watershed.

⁵ *Ibid.*

includes toxicity monitoring will be conducted in August. The second dry weather monitoring event will take place during February unless sampling during another month is deemed to be necessary or preferable.

All reasonable efforts will be made to monitor the first significant rain event of the storm year (first flush). The targeted storm events for wet weather sampling will be selected based on a reasonable probability that the events will result in substantially increased flows in the LAR mainstem over at least 12 hours; however, it may be necessary to target smaller storms in some instances. Sufficient precipitation is needed to produce runoff and increase flow. The decision to sample a storm event will be made in consultation with weather forecasting information services after a quantitative precipitation forecast (QPF) has been determined. All efforts will be made to collect wet weather samples from all sites during a single targeted storm event. However, safety or other factors may make it infeasible to collect some or all samples from a given storm event. For example, storm events that will require field crews to collect wet weather samples during holidays and/or weekends may not be sampled due to sample collection or laboratory staffing constraints.

Additional information to support evaluating weather conditions, collecting grab and composite samples, and targeting wet weather sampling events is provided in **Attachment C**.

2.4 MONITORING COORDINATION

This CIMP is written to outline the monitoring requirements to assess the MS4 Permit requirements. As part of implementation of this CIMP, the ULARWMAG has identified opportunities to coordinate monitoring efforts with other monitoring programs (e.g., WRPs and downstream CIMPs) within the watershed and will continue to seek additional opportunities to coordinate monitoring efforts. Known instances where data from other programs may be used to support the ULARWMAG meet monitoring requirements are identified in **Section 10**.

2.5 RECEIVING WATER MONITORING SUMMARY

A summary of how the receiving water monitoring program meets the intended objectives of the receiving water monitoring program outlined in Part II.E.1 of the MRP is presented in **Table 8**. The schedule for implementing receiving water monitoring is presented in **Section 13**.

Table 8. Summary of Receiving Water Monitoring Program Objectives

MRP Objective	CIMP Component Meeting Objective
Determine whether the RWLs are being achieved.	<ul style="list-style-type: none"> • Twenty-One (21) total receiving water monitoring sites. • Receiving water monitoring sites located as required by TMDLs. • Constituents added for monitoring based on the water quality priorities (i.e., the constituents at the highest risk of exceeding RWLs).
Assess trends in pollutant concentrations over time, or during specified conditions.	<ul style="list-style-type: none"> • Two LTA monitoring sites established within the ULARWMAG EWMP area. • Monitoring at all but two previously monitored water quality TMDL receiving water monitoring sites within the ULARWMAG EWMP area to be continued. • Monthly bacteria monitoring at sixteen (16) receiving water monitoring sites. • Monthly (approximately) metals monitoring at ten (10) receiving water monitoring sites. • Monitoring during dry weather and wet weather at frequency specified in the MRP. • Constituents added for monitoring based on the water quality priorities.
Determine whether the designated beneficial uses are fully supported as determined by water chemistry, as well as aquatic toxicity and bioassessment monitoring.	<ul style="list-style-type: none"> • At least one monitoring site located in the majority of waterbodies specified in the Basin Plan. • Aquatic toxicity monitoring to be conducted during dry and wet weather. • Constituents added for monitoring based on the water quality priorities.

3 MS4 Infrastructure Database

To meet the requirements of Part VII.A of the MRP, a map(s) and/or database of the MS4's storm drains, channels, and outfalls must be submitted with this CIMP and include detailed information (as described in the Permit, page E20-21). Each year, the map and associated database are required to be updated to incorporate the most recent characterization data for outfalls with significant NSW discharge.

The NSW Outfall Program requires the development of an MS4 outfall database by the time that this CIMP is submitted. The objective of the MS4 database is to geographically link the characteristics of the outfalls within the ULARWMAG EWMP area with watershed characteristics including: subwatershed, waterbody, land use, and effective impervious area. To meet this requirement, the information was compiled into geographic information systems (GIS) layers as described in the following subsections.

3.1 AVAILABLE INFORMATION

A GIS database was submitted concurrently with this CIMP and contains the elements described in **Table 9**. Given that the ULARWMAG is continually gathering information and that the information being gathered is continually being imported into the ULARWMAG's GIS layers, **Table 9** represents a snapshot of the elements that are available at the date of submittal of this CIMP.

Table 9. MS4 Database Elements Submitted with CIMP

Permit Requirement	Database Element	Submitted
VII.A.1	Surface water bodies within the ULARWMAG jurisdictions.	X
VII.A.2	Watershed (HUC-12) boundary.	X
VII.A.3	Land use overlay.	X
VII.A.5	Jurisdictional boundaries.	X
VII.A.6	The location and length of all open channel and underground pipes 18 inches in diameter or greater (with the exception of catch basin connector pipes).	X
VII.A.7	The location of all dry weather diversions.	X
VII.A.8	The location of all major MS4 outfalls within the Permittee's jurisdictional boundary with each major outfall assigned an alphanumeric identifier.	X ⁽¹⁾
VII.A.10	Storm drain outfall catchment areas for each major outfall within the Permittee(s) jurisdiction.	X ⁽²⁾
Each mapped MS4 outfall shall be linked to a database containing descriptive and monitoring data associated with the outfall. The data shall include:		
VII.A.11.a	Ownership	X
VII.A.11.b	Coordinates	X
VII.A.11.c	Physical description	X

1. All outfalls greater than 36 inches have been identified and are considered major. Outfalls that are considered "major" for other reasons as identified in the Permit (see Permit Attachment A page A-11 for complete definition of major outfalls) have not been defined at this time. The database will be updated as information is developed.

- Storm drain outfalls were linked in the database to the modeling subwatersheds to provide information on the contributing areas. Detailed analysis of storm drain outfall catchment areas for the stormwater outfall monitoring sites have been developed and additional detailed analysis will be conducted as described in **Table 10**.

3.2 PENDING INFORMATION AND SCHEDULE FOR COMPLETION

The elements described in **Table 10** represent pending information that is primarily expected to be an outcome of implementing the NSW Outfall Program as noted in the **Table 10** footnotes. As such, a schedule for completing each of the elements is provided. As the data become available, they will be entered into the GIS and water quality databases. Each year, the storm drains, channels, outfalls, and associated databases will be updated to incorporate the most recent characterization data for outfalls with significant NSW discharge. The updates will be included as part of the annual reporting to the Regional Board.

Table 10. MS4 Database Elements to Be Developed

Permit Requirement	Database Element	To Be Developed	Date of Submission
VII.A.4	Effective Impervious Area (EIA) overlay (if available).		As Available
VII.A.9	Notation of outfalls with significant NSW discharges (to be updated annually).	X ¹	December 2015
VII.A.10	Detailed analysis of storm drain outfall catchment areas for any new outfall monitoring locations, outfalls identified as having significant NSW discharges, and outfalls addressed by structural BMPs.	X ²	Ongoing
Each mapped MS4 outfall shall be linked to a database containing descriptive and monitoring data associated with the outfall. The data shall include:			
VII.A.11.d	Photographs of the outfall, where possible, to provide baseline information to track operation and maintenance needs over time	X ³	December 2015
VII.A.11.e	Determination of whether the outfall conveys significant NSW discharges.	X ¹	December 2015
VII.A.11.f	Stormwater and non-stormwater monitoring data	X ⁴	Ongoing

- The determination of significant will be made after the initial screening process outlined in this CIMP is completed using the criteria presented in **Section 5.2**.
- Storm drain outfalls were linked in the database to the modeling subwatersheds to provide information on the contributing areas. Detailed analysis of storm drain outfall catchment areas for the stormwater outfall monitoring sites have been developed and additional detailed analysis for any new outfall monitoring locations, outfalls identified as having significant NSW discharges, and outfalls addressed by structural BMPs will be conducted as needed.
- These data will be gathered as part of the screening and monitoring program and will be added to the database as they are gathered.
- These data will be gathered as part of the screening and monitoring program and will be added to a separate water quality database as they are gathered.

4 Stormwater Outfall Monitoring

As outlined in the MRP (Part VIII.A of the MRP), stormwater discharges from the MS4 shall be monitored at outfalls and/or alternative access points such as manholes or in channels representative of the land uses within the Permittee's jurisdiction to support meeting the three objectives of the stormwater outfall based monitoring program:

- a. Determine the quality of a Permittee's discharge relative to municipal action levels, as described in Attachment G of MS4 Permit;
- b. Determine whether a Permittee's discharge is in compliance with applicable WQBELs derived from TMDL WLAs; and
- c. Determine whether a Permittee's discharge causes or contributes to an exceedance of RWLs.

4.1 STORMWATER OUTFALL MONITORING SITES

Twelve sites were selected based on an evaluation of the land uses draining to the outfall location, the jurisdictions draining to the outfall location (with an emphasis placed on receiving drainage from as many jurisdictions as possible), the safety and accessibility of the site, and the ability to use autosampler equipment at the location. As described in **Attachment B**, the ULARWMAG reviewed the HUC-12 Equivalent boundaries (as per a memorandum issued by the Regional Board on March 24, 2014) and found that placing sites solely based on those boundaries would result in stormwater outfall sites that were not directly tied to receiving water monitoring. In addition, areas where the HUC-12 Equivalents spanned multiple tributaries and reaches of interest would be underrepresented. As such, the one outfall per HUC-12 Equivalent coordinated approach was slightly modified to a one outfall per major subwatershed approach. The primary criterion for selecting the monitoring sites was the representativeness of the land uses within the outfall catchment area as compared to the subwatershed area as a whole. The selected sites are representative of the land uses within each respective watershed area as shown in **Table 13**. The data collected at the monitored outfalls will be considered representative of all MS4 discharges within the subwatershed area. The resulting data will be applied to all ULARWMAG members represented by the site, regardless of whether a site is located within a particular jurisdiction. Because of this approach, evaluation of whether ULARWMAG members caused or contributed to exceedances of WQBELs and/or RWLs may be based on comingled discharges or data not collected within a given jurisdiction.

A "representative" approach to characterizing stormwater discharges is used rather than selecting individual sites for each jurisdiction. The "representative" approach provides the level of information necessary to support management decisions and evaluate whether MS4 discharges cause or contribute to exceedances. The "representative" approach also allows for a coordinated approach aimed at assessing inter-event variability (e.g., for different storm events) in stormwater discharge quality which is much greater than the variability between individual outfall drainages or major land uses. Based on stormwater monitoring results from other programs in California, discharge quality from drainages with similar mixed land uses is not substantially different. Furthermore, due to the high variability in discharge quality at any given site during wet weather, it will be impossible to distinguish statistically between drainages. As such, given the high variability typical of stormwater pollutant levels, and with only a few storm

events that can be collected per year given climatic conditions, it will not be possible to make *meaningful* distinctions between drainages, either within land use types, across land use types, or between jurisdictions. Management implementation by the Permittees is also expected to be relatively consistent throughout the subwatersheds, so additional focus on geographic differences is not necessary. This means that only a few sites are needed to adequately characterize residential land use discharge quality within the ULARWMAG EWMP area. Realistically achievable changes in stormwater runoff quality or loads (e.g., 20–50% reductions) are statistically demonstrable only over relatively long periods of time (≥ 10 years). The approach to generally monitor one outfall for each subwatershed will provide the representative data needed to meet the specific MRP objectives for stormwater outfall monitoring and support management decisions of the ULARWMAG. Additional monitoring sites will not provide significant improvements in representation or characterization of discharge quality, or additional information for discharge quality management. For additional details on the analysis to support the approach to generally monitoring one outfall per subwatershed, please see **Attachment B**.

The size and composition of the LAR Reach 6 subwatershed is unique when compared with the other subwatershed areas. The LAR Reach 6 subwatershed contains the largest portion of the ULARWMAG area. In addition, it is primarily composed of the City of Los Angeles and unincorporated Los Angeles County, with a small portion of the subwatershed consisting of the cities of Calabasas and Hidden Hills. Furthermore, the LAR Reach 6 subwatershed lies adjacent to the LAR Reach 5 subwatershed, which is entirely composed of the City of Los Angeles and unincorporated County of Los Angeles, and has a similar land use breakdown to the City of Los Angeles and unincorporated County of Los Angeles portion of Reach 6. Thus, to distinguish between the differences between areas of the LAR Reach 6 subwatershed and to capitalize on the similarities between areas of the LAR Reach 6 and Reach 5 subwatersheds, two outfall monitoring sites were selected for the LAR Reach 6 subwatershed. One outfall monitoring site will be utilized to assess the cities of Calabasas and Hidden Hills and the other outfall monitoring site will be utilized to assess the areas of the cities of Calabasas and Los Angeles and the areas of the County of Los Angeles located within the LAR Reach 6 and Reach 5 subwatersheds.

The City of South El Monte is unique in that it is the only city in the ULARWMAG which has a greater area classified under the commercial/industrial land use than the residential land use. Also, the City of South El Monte discharges to two drains which subsequently discharge to the Legg Lake system. As a result, an additional stormwater outfall monitoring site will be located in the Rio Hondo subwatershed to determine the quality of stormwater being discharged by the City of South El Monte and to determine the quality of stormwater being discharged to the Legg Lake system. One outfall monitoring site was selected for all other subwatersheds yielding a total of twelve outfall monitoring sites.

Summary information for the 12 stormwater outfall monitoring sites is presented in **Table 11** and the locations are shown on **Figure 3**. **Table 12** identifies the outfalls which would be considered representative of each of the ULARWMAG members. Additionally, **Table 12** identifies the receiving waters to which the outfall sites may be considered applicable. That is, if an exceedance was observed in a receiving water, the outfall data would be reviewed to determine if a ULARWMAG member had the potential to cause or contribute to the exceedance.

Attachment B presents additional details of the sites. Additionally, alternate sites are identified in **Attachment B** in the event the primary sites are not accessible, are determined to backflow during high flow conditions to the extent that a representative sample cannot be obtained, or are unsafe for sampling. For all 12 stormwater outfall monitoring sites, if determined to be preferable, sampling may occur at a manhole located upstream of each of the location where the outfall discharges to a receiving water.

Table 11. Stormwater Outfall Monitoring Sites

Subwatershed	Site Name	Drain Name	Jurisdiction Where Site is Located	Jurisdictions Draining to the Site	Size	Shape	Latitude	Longitude
LA River Reach 2	LAR_02_SW_MAI	BI 0062 – Line A	City of LA	City of LA	147”	Rectangular	34.06720	-118.22424
LA River Reach 3	LAR_03_SW_COL	BI 9506 U01	City of LA	City of LA, Glendale	144”	Rectangular	34.13668	-118.27477
LA River Reach 4	LAR_04_SW_BUE	BI 0168 – Frederick St Drain	Burbank	Burbank	72”	Round	34.15319	-118.32545
LA River Reach 6	LAR_06_SW_WIN	BI 0477	City of LA	City of LA	108”	Rectangular	34.19097	-118.57072
LA River Reach 6	LAR_06_SW_OLD	PD 0778	Calabasas	Calabasas	45”	Round	34.14422	-118.63045
Compton Creek	CC_SW_LAN	BI 0073 – U1 Line C	City of LA	City of LA, County of LA	108”	Rectangular	33.93540	-118.25479
Rio Hondo	RH_SW_LER	BI 1213 - Line A	South El Monte	South El Monte	45”	Rectangular	34.04209	-118.05170
Rio Hondo	RH_SW_ROB	Rubio Drain	San Marino	County of LA, Pasadena, San Marino	234”	Rectangular	34.12867	-118.10036
Arroyo Seco	AS_SW_SEC	Seco St Drain	Pasadena	Pasadena, County of LA	81”	Rectangular	34.15511	-118.16757
Verdugo Wash	VW_SW_CAN	BI 0434 Northeast Glendale	Glendale	County of LA, Glendale, La Cañada Flintridge	126”	Rectangular	34.18991	-118.22734
Burbank Western Channel	BWC_SW_MAI	BI 0169	Burbank	Burbank	72”	Rectangular	34.16096	-118.30999
Tujunga Wash	TW_SW_BUR	BI 0091 (F1046)	City of LA	City of LA	81”	Round	34.17019	-118.41335

Table 12. ULARWMAG Member Represented by Each Stormwater Outfall Monitoring Site⁽¹⁾⁽²⁾

Jurisdiction	Site	LA River					Tributaries ⁽³⁾											Lakes ⁽⁴⁾		
		2	3	4	5	6	TW	BWC	VW	AS	RH	CC	BuC	ACW	MC	DC	BeC	LEG	EP	CAL
Alhambra	LAR_02_SW_MAI	D																		
	RH_SW_ROB										D									
Burbank	LAR_03_SW_COL	I	D																	
	LAR_04_SW_BUE	I	I	D																
	BWC_SW_MAI	I	I							D										
Calabasas	LAR_06_SW_WIN	I	I	I	I	I									D	D				D
	LAR_06_SW_OLD	I	I	I	I	I									D	D				D
City of Los Angeles	LAR_02_SW_MAI	D																	D	
	LAR_03_SW_COL	I	D																	
	LAR_04_SW_BUE	I	I	D																
	LAR_06_SW_WIN	I	I	I	D	D						D	D	D	D	D				
	CC_SW_LAN											D								
	AS_SW_SEC	I									D									
	VW_SW_CAN	I	I								D									
	BWC_SW_MAI	I	I								D									
	TW_SW_BUR	I	I	I				D												
County of Los Angeles	LAR_02_SW_MAI	D																		
	LAR_04_SW_BUE	I	I	D																
	LAR_06_SW_WIN	I	I	I	D	D						D	D	D	D	D				
	CC_SW_LAN											D								
	RH_SW_LER																	D		
	RH_SW_ROB											D								
	AS_SW_SEC	I									D									
	VW_SW_CAN	I	I								D									
	TW_SW_BUR	I	I	I				D												

Jurisdiction	Site	LA River					Tributaries ⁽³⁾											Lakes ⁽⁴⁾		
		2	3	4	5	6	TW	BWC	VW	AS	RH	CC	BuC	ACW	MC	DC	BeC	LEG	EP	CAL
Glendale	LAR_03_SW_COL	I	D																	
	VW_SW_CAN	I	I							D										
	BWC_SW_MAI	I	I							D										
Hidden Hills	LAR_06_SW_OLD	I	I	I	I	I									D		D			
La Cañada Flintridge	LAR_03_SW_COL	I	D																	
	VW_SW_CAN	I	I							D										
	AS_SW_SEC	I									D									
Montebello	RH_SW_ROB																			
Monterey Park	LAR_02_SW_MAI	D																		
	RH_SW_ROB																			
Pasadena	LAR_02_SW_MAI	D																		
	LAR_03_SW_COL	I	D																	
	RH_SW_ROB																			
	AS_SW_SEC	I									D									
	VW_SW_CAN	I	I								D									
Rosemead	RH_SW_ROB																			
San Fernando	TW_SW_BUR	I	I	I			D													
San Gabriel	RH_SW_ROB																			
San Marino	RH_SW_ROB																			
South El Monte	RH_SW_LER																		D	
South Pasadena	LAR_02_SW_MAI	D																		
	RH_SW_ROB																			
	AS_SW_SEC	I									D									
Temple City	RH_SW_ROB																			

1. D = Jurisdiction discharges directly; I = Jurisdiction discharges indirectly (i.e., upstream)
2. If an exceedance is observed in a waterbody, the paired data collected from the drains discharging directly and/or indirectly to the waterbody will be used to assess whether the ULARWMAG member caused or contributed to the exceedance.
3. TW(Tujunga Wash), BWC (Burbank Western Channel), VW (Verdugo Wash), AS (Arroyo Seco), RH (Rio Hondo), CC (Compton Creek), BuC (Bull Creek), ACW (Aliso Canyon Wash), MC (McCoy Canyon Creek), DC (Dry Canyon Creek), and BeC (Bell Creek)
4. LEG (Legg Lake), EP (Echo Park Lake), CAL (Lake Calabasas)

Table 13. Land Use Summaries of Subwatersheds and Stormwater Outfall Monitoring Sites

Subwatershed and Site	Percent of Jurisdiction ⁽¹⁾			
	Res	Com/Ind	Ag/Nur	Open
LA River Reach 2	54%	40%	<1%	6%
LAR_02_SW_MAI	70%	25%	<1%	5%
LA River Reach 3	64%	26%	<1%	10%
LAR_03_SW_COL	69%	23%	1%	7%
LA River Reach 4	70%	25%	1%	4%
LAR_04_SW_BUE	76%	24%	<1%	<1%
LA River Reaches 5 and 6 ⁽²⁾	69%	25%	2%	4%
LAR_06_SW_WIN	67%	31%	<1%	2%
LA River Reach 6 ⁽³⁾	79%	13%	1%	7%
LAR_06_SW_OLD	99%	1%	<1%	<1%
Compton Creek	68%	30%	<1%	2%
CC_SW_LAN	63%	35%	<1%	1%
Rio Hondo ⁽⁴⁾	33%	63%	1%	3%
RH_SW_LER	38%	56%	3%	2%
Rio Hondo ⁽⁵⁾	68%	23%	1%	8%
RH_SW_ROB	82%	16%	<1%	2%
Arroyo Seco	79%	12%	0%	9%
AS_SW_SEC	69%	25%	<1%	6%
Verdugo Wash	84%	12%	<1%	4%
VW_SW_CAN	69%	29%	<1%	2%
Burbank Western Channel	61%	34%	1%	4%
BWC_SW_MAI	71%	28%	<1%	1%
Tujunga Wash	70%	23%	2%	5%
TW_SW_BUR	86%	14%	<1%	<1%

1. Land use classifications include: residential (Res), commercial and industrial (Com/Ind), agriculture and nursery (Ag/Nur), and open space (Open). Totals correspond to the percent of the total area considered in the EWMP (i.e., only using open space characterized as golf courses, local parks, and regional parks).
2. Areas of subwatersheds within the jurisdiction of the Cities of Calabasas and Los Angeles and County of Los Angeles.
3. Area of subwatershed within the jurisdiction of the Cities of Calabasas and Hidden Hills.
4. Area of subwatershed within the jurisdiction of the City of South El Monte.
5. Area of subwatershed excluding the area within the City of South El Monte.

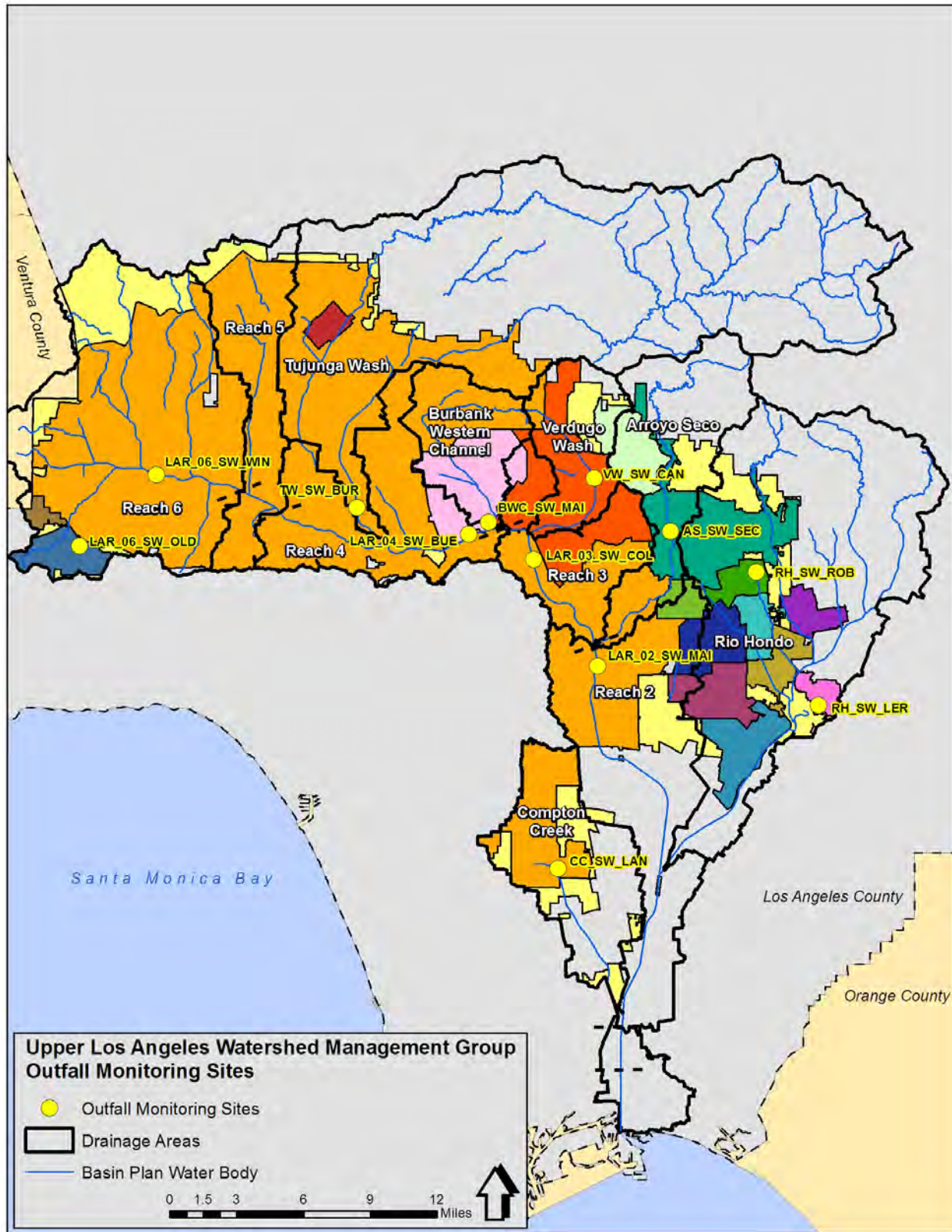

Figure 3. Stormwater Outfall Monitoring Locations Overview

4.2 MONITORED PARAMETERS AND FREQUENCY

The requirements for parameters to be monitored are outlined in the Part VIII.B.1.c of the MRP. Parameters that will be monitored during three events at each stormwater outfall monitoring site are presented in **Table 14** and meet the requirements of Part VIII.B.1.c of the MRP because they are based on the monitoring requirements of the waterbody to which they discharge, as well as downstream waterbodies. This list will continue to meet the requirements of Part VIII.B.1.c of the MRP because it was generated from the current list of constituents monitored during wet weather in the receiving waters and will be updated as the constituents monitored during wet weather in the waterbody to which they discharge, as well as downstream waterbodies, are updated and/or changed based upon the data collected at the individual outfall site. The current list of constituents addresses water quality priorities for Categories 1, 2 and 3 WBPCs in the receiving water or downstream receiving waters, except as noted in **Attachment A**.

As stated in Part VIII.B.1.c, SSC is only required to be monitored if the receiving water is listed on the Clean Water Act (CWA) Section 303(d) list for sedimentation, siltation, or turbidity. Given that none of the receiving waters in the LAR watershed are listed on the CWA Section 303(d) list for sedimentation, siltation, or turbidity, SSC is not required to be monitored at any of the stormwater outfall monitoring sites. However, for the ULAR CIMP, SSC will be utilized in the approach for evaluating concentrations of organics associated with stormborne sediment. The two relevant application of this approach relate to monitoring associated with the Harbors Toxics TMDL and the Echo Park Lake Toxics TMDL. As described in **Section 10**, monitoring for the Harbors Toxics TMDL will be initiated in the receiving water by the Lower Los Angeles River (LLAR) WMP group to assess contributions from the watershed. The ULAR EWMP group is coordinating with the LLAR WMP group to utilize the data to assess overall loading from the watershed and, if the findings indicate loadings are causing or contributing to the impairment, monitoring within the ULAR EWMP group area will be initiated to determine contributions. At that time, SSC monitoring will be added to any corresponding receiving water and outfall monitoring locations. For the Echo Park Lake Toxics TMDL, the representative outfall site LAR_02_SW_MAI will be monitored for organics in stormborne sediment. As such, SSC will be monitored at LAR_02_SW_MAI.

Outfalls will be monitored for all required constituents except toxicity. Toxicity monitoring will occur when triggered by receiving water toxicity monitoring and TIE results. Wet weather events for stormwater outfall monitoring will occur simultaneously with receiving water monitoring to the extent possible. To be consistent with receiving water monitoring, stormwater outfall monitoring will consist of collecting composite samples (except in certain situations as described in **Section 2.3**). Wet weather conditions for targeted storm events are described in **Section 2.3** and **Attachment C**. Analytical methods, detection limits, sampling methods, and sample handling procedures are detailed in **Attachment C**. In addition, details regarding the collection of QA/QC samples are outlined in **Attachment C**.

Table 14. List of Parameters for Stormwater Outfall Monitoring⁽¹⁾

Parameters	Subwatershed ⁽²⁾											
	Reach 2	Reach 3	Reach 4	Reach 6	Reach 6	CC	RH	RH	AS	VW	BWC	TW
Site ID	LAR_02_ SW_MAI	LAR_03_ SW_COL	LAR_04_ SW_BUE	LAR_06_ SW_WIN	LAR_06_ SW_OLD	CC_SW _LAN	RH_SW _LER	RH_SW _ROB	AS_SW _SEC	VW_SW _CAN	BWC_SW _MAI	TW_SW _BUR
Flow, hardness, pH, dissolved oxygen, temperature, and specific conductivity	X	X	X	X	X	X	X	X	X	X	X	X
TSS	X	X	X	X	X	X	X	X	X	X	X	X
Table E-2 pollutants of the MRP detected above relevant objectives and not otherwise addressed below	X	X	X	X	X	X	X	X	X	X	X	X
Cadmium (total and dissolved)	X	X	X	X	X	X	X	X	X	X	X	X
Copper (total and dissolved)	X	X	X	X	X	X	X	X	X	X	X	X
Lead (total and dissolved)	X	X	X	X	X	X	X	X	X	X	X	X
Zinc (total and dissolved)	X	X	X	X	X	X	X	X	X	X	X	X
Mercury (total)	X	X	X	X	X	X	X	X	X	X	X	X
Suspended Sediment: Chlordane ⁽³⁾ , PCBs ⁽³⁾ , and Dieldrin	X ⁽⁴⁾											
SSC	X											

Parameters	Subwatershed ⁽²⁾											
	Reach 2	Reach 3	Reach 4	Reach 6	Reach 6	CC	RH	RH	AS	VW	BWC	TW
Site ID	LAR_02_ SW_MAI	LAR_03_ SW_COL	LAR_04_ SW_BUE	LAR_06_ SW_WIN	LAR_06_ SW_OLD	CC_SW _LAN	RH_SW _LER	RH_SW _ROB	AS_SW _SEC	VW_SW _CAN	BWC_SW _MAI	TW_SW _BUR
Ammonia as N, Nitrate as N, Nitrite as N, and Nitrate+Nitrite Nitrogen (NO3- N+NO2-N), TKN or Organic Nitrogen, Orthophosphate, Total Phosphorus, and TDS	X ⁽⁴⁾				X ⁽⁴⁾		X ⁽⁴⁾					

1. As described in **Section 11**, data collected as part of the ULARWMAG CIMP will be reviewed and changes to the constituents and frequencies as a result of exceedances in the receiving waters or as a result of toxicity testing will be discussed in the annual report and implemented starting no later than the first CIMP event of the next monitoring year (i.e., the first event after July 1 of the year following the annual report submittal).
2. CC (Compton Creek), RH (Rio Hondo), AS (Arroyo Seco), VW (Verdugo Wash), BWC (Burbank Western Channel), and TW (Tujunga Wash)
3. See **Table 5** for a summary of the constituents that comprise chlordane and PCBs.
4. Nutrients and TDS to be monitored twice per year and suspended sediment to be monitored once per year to satisfy the Los Angeles Area Lakes TMDLs monitoring requirements specified in Part XIX.D of the MRP.

4.3 STORMWATER OUTFALL MONITORING SUMMARY

A summary of how the stormwater outfall monitoring program meets the intended objectives of the stormwater outfall monitoring program outlined in Part VIII.A of the MRP is presented in **Table 15**. The schedule for implementing stormwater outfall monitoring is presented in **Section 13**.

Table 15. Summary of Stormwater Outfall Monitoring Program Objectives

MRP Objective	CIMP Component Meeting Objective
Determine the quality of a Permittee's discharge relative to municipal action levels, as described in Attachment G of MS4 Permit.	<ul style="list-style-type: none"> • Stormwater outfall monitoring sites chosen using a representative land use approach. • Extensive list of constituents being collectively monitored at stormwater outfall monitoring sites.
Determine whether a Permittee's discharge is in compliance with applicable WQBELs derived from TMDL WLAs.	<ul style="list-style-type: none"> • Stormwater outfall monitoring sites located in waterbodies with applicable WQBELs. • Stormwater outfall monitoring sites chosen using a representative land use approach. • List of constituents based on the water quality priorities which includes constituents with WQBELs derived from TMDL WLAs and considers current and historical exceedances in receiving waters.
Determine whether a Permittee's discharge causes or contributes to an exceedance of RWLs.	<ul style="list-style-type: none"> • Stormwater outfall monitoring sites chosen to be representative of each subwatershed. • Monitoring frequency equal to receiving water monitoring frequency to enable determination of whether the Permittee's discharge is causing or contributing to any observed exceedances of water quality objectives in the receiving water. • Stormwater outfall monitoring sites chosen using a representative land use approach. • List of constituents based on the monitoring requirements of the waterbody to which they discharge, as well as downstream waterbodies.

5 Non-Stormwater Outfall Program

The objectives of the NSW Outfall Program include the following (Part II.E.3 of the MRP):

- a. Determine whether a Permittee's discharge is in compliance with applicable NSW QBELs derived from TMDL WLAs;
- b. Determine whether a Permittee's discharge exceeds NSW action levels, as described in Attachment G of the MS4 Permit;
- c. Determine whether a Permittee's discharge contributes to or causes an exceedance of RWLs; and
- d. Assist a Permittee in identifying illicit discharges as described in Part VI.D.10 of the MS4 Permit.

Additionally, the outfall screening and monitoring process is intended to meet the following objectives (Part IX.A of the MRP):

1. Develop criteria or other means to ensure that all outfalls with significant NSW discharges are identified and assessed during the Permit term.
2. For outfalls determined to have significant NSW flow, determine whether flows are the result of illicit connections/illicit discharges (IC/IDs), authorized or conditionally exempt NSW flows, natural flows, or from unknown sources.
3. Refer information related to identified IC/IDs to the IC/ID Elimination Program (Part VI.D.10 of the Permit) for appropriate action.
4. Based on existing screening or monitoring data or other institutional knowledge, assess the impact of NSW discharges (other than identified IC/IDs) on the receiving water.
5. Prioritize monitoring of outfalls considering the potential threat to the receiving water and applicable TMDL compliance schedules.
6. Conduct monitoring or assess existing monitoring data to determine the impact of NSW discharges on the receiving water.
7. Conduct monitoring or other investigations to identify the source of pollutants in NSW discharges.
8. Use results of the screening process to evaluate the conditionally exempt NSW discharges identified in Parts III.A.2 and III.A.3 of the Permit and take appropriate actions pursuant to Part III.A.4.d of the Permit for those discharges that have been found to be a source of pollutants. Any future reclassification shall occur per the conditions in Parts III.A.2 or III.A.6 of the Permit.
9. Maximize the use of Permittee resources by integrating the screening and monitoring process into existing or planned CIMP efforts.

5.1 NON-STORMWATER OUTFALL SCREENING AND MONITORING PROGRAM

The NSW Outfall Program is focused on NSW discharges to receiving waters from major outfalls (i.e., discharges occurring during dry weather). The NSW Outfall Program is designed to

be complimentary to the individual ULARWMAG members IC/ID programs, established under Part VI.D.10 of the Permit.

In summary, the intent of the NSW Outfall Program is to demonstrate that the Permittees are effectively prohibiting NSW discharges that are not exempt or conditionally exempt discharges to receiving waters and to assess whether NSW discharges are causing or contributing to exceedances of RWLs. By detecting, identifying, and eliminating illicit discharges, the NSW Outfall Program will demonstrate Permittees' efforts to effectively prohibit NSW discharges to and from the MS4. Where NSW discharges are deemed "significant", the program will discern whether they are illicit, exempt, or conditionally exempt, and demonstrate whether the discharges may be causing or contributing to exceedances of RWLs.

For the receiving water and stormwater outfall monitoring programs, sufficient information is available, including guidance from the MRP, to support the identification of sites and begin the process of initiating water quality monitoring upon approval of this CIMP. For the NSW Outfall Program, the MRP specifies a process for screening, investigating, and ultimately monitoring. The outfall screening and investigation is intended to be completed prior to initiating monitoring for all constituents of interest at an individual outfall. A summary of the approach to address the required elements of the NSW Outfall Program is presented in **Table 16**. **Figure 4** presents a NSW Outfall Program flow diagram. Detailed discussion of each element is provided in the following subsections.

The water quality priorities and corresponding receiving water conditions were used to establish an approach for the NSW Outfall Program to ensure that, if actions must be taken at a storm drain, there is a corresponding water quality issue in the receiving water. Based on a review of the available information, *E. coli* was identified as the water quality priority that appears to be most appropriate for use when determining the significance of a NSW discharge for the following reasons:

1. Of the constituents addressed by TMDLs for which WQBELs and RWLs were incorporated into the Permit, *E. coli* consistently exceeds RWLs. Metals and nutrients appear to consistently meet the dry weather RWLs. All other TMDL-related WQBELs and RWLs are primarily associated with wet weather discharges.
2. Based on the Los Angeles River Bacteria Source Identification (BSI) Study (CREST 2008) conducted in Reaches 2 and 4, concentrations of *E. coli* in storm drain discharges ranged from non-detect to ~73 million MPN/100mL, with median concentrations around 1000 MPN/mL (an order of magnitude higher than the LAR Bacteria TMDL WQBELs and RWLs of 235 MPN/mL and 126 MPN/mL, respectively).
3. The Permit requires Permittees to conduct outfall monitoring to support implementation and/or compliance determination.
4. The LAR Bacteria TMDL provides a phased approach to implementation that can form the basis of phasing the implementation of the NSW Outfall Program, which appears appropriate given the size of the ULARWMAG EWMP area. The phasing of the approach would follow the prioritization of LA River segments and tributaries utilized in the TMDL and incorporated into the Permit.

5. The LAR Bacteria TMDL requires outfall monitoring, and combining those efforts with the NSW Outfall Program will allow Permittees to maximize their resources.

Although the initial focus of the NSW Outfall Program will be on supporting and integrating the requirements with the LAR Bacteria TMDL, this approach will consider the broader requirements of the Permit. Additionally, the NSW Outfall Program will likely be modified over time to reflect changing priorities within the ULARWMAG EWMP area.

Table 16. Summary of the NSW Outfall Program Elements

Element	Description	Timing of Completion
1. Outfall Screening	Because data required to implement the NSW Outfall Program are not available, the Permittees will implement a screening process to determine which outfalls exhibit significant NSW discharges and those that do not require further investigation.	Outfall Screening process to commence as outlined in Section 13 and all elements will be completed prior to initiating source investigations.
2. Identification of outfalls with significant NSW discharge (Part IX.C of the MRP)	Based on data collected during the Outfall Screening process, Permittees will identify MS4 outfalls with significant NSW discharges.	
3. Inventory of Outfalls with NSW discharge (Part IX.D of the MRP)	Permittees will develop an inventory of major MS4 outfalls with known significant NSW discharges and those requiring no further assessment.	
4. Prioritized source investigation (Part IX.E of the MRP)	The Permittees will use the data collected as part of the Outfall Screening process to prioritize outfalls for source investigations.	
5. Identify sources of significant NSW discharges (Part IX.F of the MRP)	For outfalls exhibiting significant NSW discharges, the Permittees will perform source investigations per the established prioritization.	Source investigations will be conducted for 25% of the outfalls with significant NSW discharges by one year after a new set is identified and 100% by three years after the new set is identified.
6. Monitoring NSW discharges exceeding criteria (Part IX.G of the MRP)	Using the information collected during screening and source investigation efforts, the Permittees will monitor outfalls that have been determined to convey significant NSW discharges comprised of either unknown or non-essential conditionally exempt NSW discharges, or continuing discharges attributed to illicit discharges.	Monitoring will commence as outlined in Section 13 .

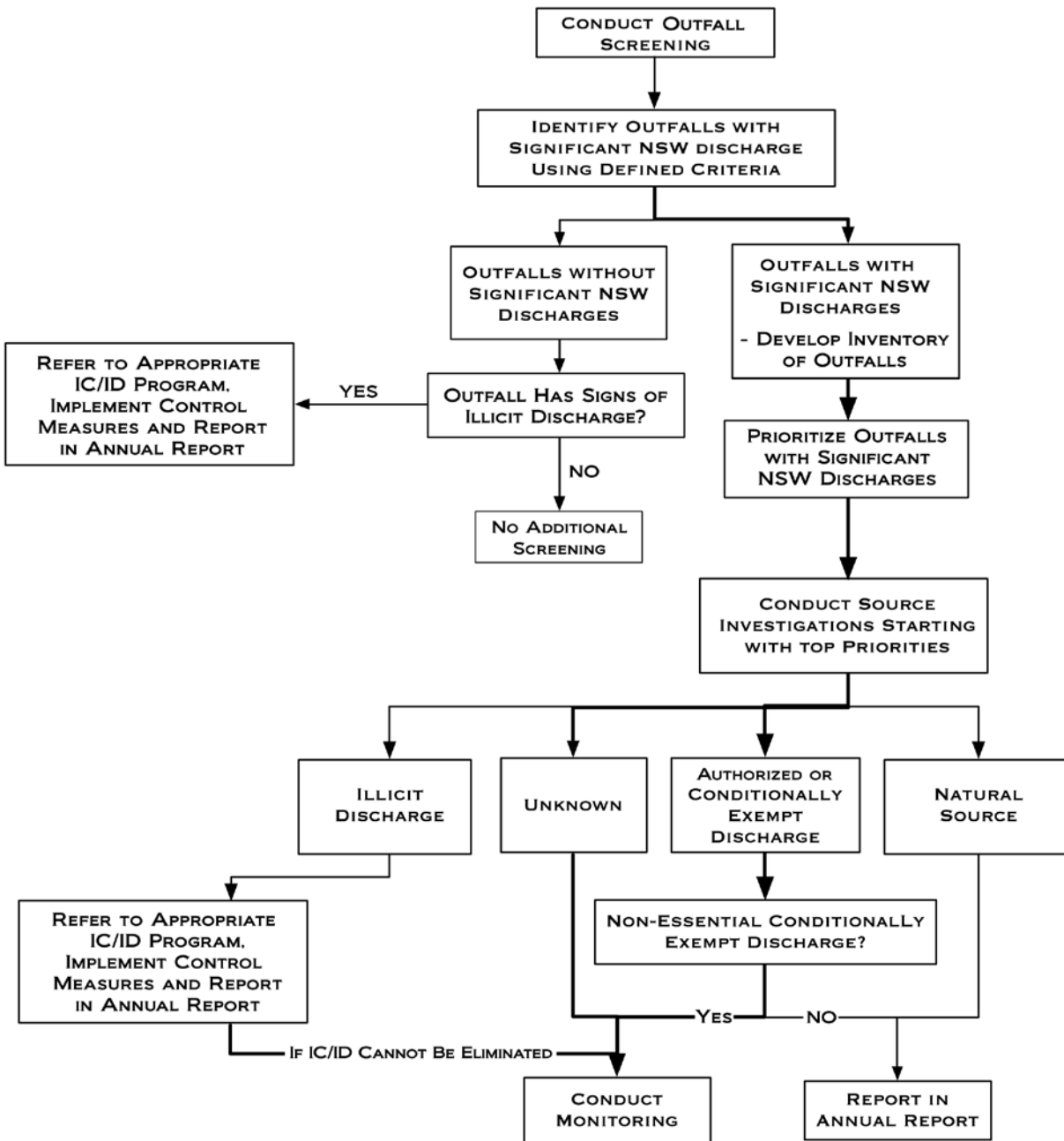

Figure 4. NSW Outfall Program Flow Diagram

5.2 IDENTIFICATION OF OUTFALLS WITH SIGNIFICANT NON-STORMWATER DISCHARGES

The data necessary to identify significant NSW discharges are not available at this time. Thus, outfall screening is necessary to collect the information to identify major outfalls exhibiting significant NSW discharges and develop the information needed for the inventory of outfalls with significant NSW discharges. The MRP (Part IX.C.1) states that other characteristics, as determined by the Permittee and incorporated within the screening program, may be used to determine significant NSW discharges. Data will be collected during the Outfall Screening

process to focus efforts on discharges that have, or the potential to have, an impact on receiving waters. For the reasons stated above, *E. coli* loading will serve as the primary characteristic for determining significant NSW discharges. **Table 17** presents the components of the Outfall Screening process and the characteristics that will be utilized to determine the outfalls with significant NSW discharges.

Table 17. Approach for Establishing an Outfall Screening Process Utilizing *E. coli* Loading as the Key Characteristic for Determining Significant Non-Stormwater Discharges

Component	Description
Characteristics for Defining Significant NSW Discharges	<p>Outfalls will be determined to be significant NSW discharges based on the Load Reduction Strategy (LRS)⁽¹⁾ approach outlined in the LA River Bacteria TMDL. The approach considers the first two aspects of the discharge described immediately below and the determination of significant NSW is described as the criteria in bold:</p> <ul style="list-style-type: none"> ○ Does the non-stormwater discharge reach the receiving water during dry weather? If yes, continue through the ranking criteria. ○ Is the <i>E. coli</i> <u>concentration</u> in the NSW discharge above receiving water limits? If yes, continue through the ranking criteria. <p><i>E. coli</i> loading rate: the identification of outfalls with significant NSW discharge is based on conducting a quantitative analysis (i.e., Monte Carlo modeling) to: (1) evaluate both the individual and cumulative <i>E. coli</i> loading rates from outfalls along a LA River segment or tributary before and after implementation actions, and (2) prioritize implementation actions based on these <i>E. coli</i> loading rates. The LRS process described by the TMDL, which will be used for the NSW Program, is based around identification of, two categories of outfalls, as follows:</p> <ul style="list-style-type: none"> ○ Priority Outfalls –The LRS prioritization process highlights the Priority Outfalls because they have the highest loading rates of <i>E. coli</i>. Overall, Priority Outfalls have relatively consistent, problematic discharges that both drive storm drain loading rates above the WLA. As such, Priority Outfalls are the highest priority for specific implementation actions in the LRS. ○ Outlier Outfalls are outfalls identified by retrospectively comparing the results of the Monte Carlo simulations to the “raw” monitoring data.
Data Collection	<p>Data that will be collected include accurate flow measurements and <i>E. coli</i> concentration. Additionally, the information needed to complete the inventory as described in Section 5.3 will be collected.</p>
Frequency	<p>Three times as part of the initial screening process, unless monitoring has already been conducted. The remaining three monitoring events to meet the requirements of the LA River Bacteria TMDL LRS process would be completed as part of the NSW outfall monitoring described in Section 5.6. Screening in subsequent Permit terms would be identified prior to the completion current of the Permit term.</p>

1. See the LA River Bacteria TMDL Staff Report for additional details on the Load Reduction Strategy process for identifying significant and outlier outfalls.

5.3 INVENTORY OF MS4 OUTFALLS WITH NON-STORMWATER DISCHARGES

An inventory of MS4 outfalls will be developed identifying those outfalls with known significant NSW discharges and those requiring no further assessment (Part IX.D of the MRP). If the MS4 outfall requires no further assessment, the inventory will include the rationale for the determination of no further action required. Potential rationale for a determination of no further action could include: 1) the outfall does not have flow; 2) the outfall does not have a known significant NSW discharge; or 3) discharges observed were determined to be exempted. The

inventory will be recorded in the database required in Part VII.A of the MRP. Each year, the inventory will be updated to incorporate the most recent characterization data for outfalls with significant NSW discharges.

The following physical attributes of outfalls with significant NSW discharges will be included in the inventory and will be collected as part of the Outfall Screening process:

- a. Date and time of last visual observation or inspection
- b. Outfall alpha-numeric identifier
- c. Description of outfall structure including size (e.g., diameter and shape)
- d. Description of receiving water at the point of discharge (e.g., natural, soft-bottom with armored sides, trapezoidal, concrete channel)
- e. Latitude/longitude coordinates
- f. Nearest street address
- g. Parking, access, and safety considerations
- h. Photographs of outfall condition
- i. Photographs of significant NSW discharge (or indicators of discharge) unless safety considerations preclude obtaining photographs
- j. Estimation of discharge rate
- k. All diversions either upstream or downstream of the outfall
- l. Observations regarding discharge characteristics such as turbidity, odor, color, presence of debris, floatables, or characteristics that could aid in pollutant source identification.

5.4 PRIORITIZED SOURCE IDENTIFICATION

Once the major outfalls exhibiting significant NSW discharges have been identified through the Outfall Screening process and incorporated into the inventory, Part IX.E of the MRP requires that the Permittees prioritize the outfalls for further source investigations. Once the prioritization is completed, a source identification schedule will be developed. As described in **Section 13**, the Outfall Screening process will be conducted in phases. Because the phased process is based on the prioritized waterbody approach in the LA River Bacteria TMDL, a schedule is essentially captured in the multiple phases conducted over the current and future Permit terms. As additional screening events are conducted, a new set of outfalls with significant NSW discharges may be identified. As such, it is recommended that the following schedule be used for conducting source investigations on each new set of outfalls with significant NSW discharges that are identified: 25% of the outfalls with significant NSW discharges by one year after a new set is identified and 100% by three years after the new set is identified.

As the approach for identifying significant NSW discharges already focuses on addressing outfalls based upon each outfall's potential effect on attaining the requirements of the LA River Bacteria TMDL, the following prioritization criteria will be utilized initially and may be revised as priorities in the EWMP area change:

1. Priority Outfalls identified through the Monte Carlo analysis⁶.

⁶ Mathematical method identified in the Los Angeles River Bacteria TMDL Staff Report used to conduct the analysis of outfall data and identify priority and outlier outfalls.

2. Outlier Outfalls identified through the Monte Carlo analysis.

Both the source identification prioritization criteria and scheduling may be revised upon completion of the first phase of implementation of the NSW Screening and Outfall Program.

5.5 SIGNIFICANT NON-STORMWATER DISCHARGE SOURCE IDENTIFICATION

As described in the Fact Sheet for the Permit, the screening and source identification components of the program are used to identify the source(s) and point(s) of origin of the NSW discharge. Based on the prioritized list of major outfalls with significant NSW discharges, investigations must be conducted to identify the source(s) or potential source(s) of non-stormwater flows.

Part IX.A.2 of the MRP requires Permittees to classify the source investigation results into one of four endpoints outlined as follows and summarized in **Table 18**:

- A. Illicit connections or illicit discharges: If the source is determined to be an illicit discharge, the Permittee must implement procedures to eliminate the discharge consistent with IC/ID requirements (Permit Part VI.D.10) and document actions.
- B. Authorized or conditionally exempt NSW discharges: If the source is determined to be an NPDES permitted discharge, a discharge subject to the Comprehensive Environmental Response, Compensation, and Liability Act (CERCLA), or a conditionally exempt essential discharge, the Permittee must document the source. For non-essential conditionally exempt discharges, the Permittee must conduct monitoring consistent with Part IX.G of the MRP to determine whether the discharge should remain conditionally exempt or be prohibited.
- C. Natural flows: If the source is determined to be natural flows, the Permittee must document the source.
- D. Unknown sources: If the source is unknown, the Permittee must conduct monitoring consistent with Part IX.G of the MRP.

Table 18. Summary of Endpoints for Source Identification

Endpoint	Follow-up	Action Required by Permit
A. Illicit Discharge or Connection	Refer to IC/ID program	Implement control measures and report in annual report. Monitor if cannot be eliminated.
B. Authorized or Conditionally Exempt Discharges ¹	Document and identify if essential or non-essential	Monitor non-essential discharges
C. Natural Flows	End investigation	Document and report in annual report
D. Unknown	Refer to IC/ID program	Monitor

1. Discharges authorized by a separate NPDES permit, a discharge subject to a Record of Decision approved by United States Environmental Protection Agency (USEPA) pursuant to section 121 of CERCLA, or is a conditionally exempt NSW discharge addressed by other requirements. Conditionally exempt NSW discharge addressed by other requirements are described in detail in Part III.A. Prohibitions – Non-Stormwater Discharges of the Permit.

Source investigations will be conducted using site-specific procedures based on the characteristics of the NSW discharge and the techniques utilized by the individual Permittee's IC/ID program conducting the investigation. Investigations could include:

- Gathering additional field measurements to characterize the discharge.
- Following dry weather flows from the location where they are first observed in an upstream direction along the conveyance system.
- Compiling and reviewing available resources including past monitoring and investigation data, land use/MS4 maps, aerial photography, and property ownership information.

Where investigations determine the NSW source to be authorized, natural, or essential conditionally exempt flows, the investigation will be concluded and the next highest priority outfall will then be investigated. Where investigations determine that the source of the discharge is non-essential conditionally exempt, an illicit discharge, or is unknown – further investigation will be considered to eliminate the discharge or demonstrate that it is not causing or contributing to receiving water impairments. In some cases, source investigations may ultimately lead to prioritized programmatic or structural BMPs. Where Permittees determine that the NSW discharge will be addressed through modifications to programs or by structural BMP implementation, the Permittee will incorporate the approach into the implementation schedule developed in the EWMP, and the outfall will be lowered in priority for investigation, such that the next highest priority outfall is addressed.

5.6 NON-STORMWATER DISCHARGE MONITORING

As outlined in the MRP (Part II.E.3), outfalls with significant NSW discharges that remain unaddressed after source investigation shall be monitored to meet the following objectives:

- a. Determine whether a Permittee's discharge is in compliance with applicable NSW WQBELs derived from TMDL WLAs;
- b. Determine whether the quality of a Permittee's discharge exceeds NSW action levels, as described in Attachment G of the Permit; and,
- c. Determine whether a Permittee's discharge causes or contributes to an exceedance of RWLs.

Thus, outfalls that are determined to convey significant NSW discharges where the source investigations conclude that the source is attributable to a continued illicit discharge (Endpoint A from **Table 18**), non-essential conditionally exempt (Endpoint B from **Table 18**), or unknown (Endpoint D from **Table 18**), must be monitored. Monitoring will begin within 90 days of completing source investigations or after the Executive Officer approves this CIMP, whichever is later.

Monitoring for non-stormwater discharges will be more dynamic than either the receiving water or stormwater outfall monitoring. As non-stormwater discharges are addressed, monitoring at the outfall will cease. Additionally, if monitoring demonstrates that discharges do not exceed any WQBELs, non-stormwater action levels, or water quality standards for pollutants identified on the 303(d) list, monitoring will cease at an outfall after the first year or specific pollutants will be

no longer be analyzed. Thus, the number and location of outfalls monitored as well as the pollutants monitored has the potential to change on an annual basis. The process for adapting monitoring locations and frequency is presented in **Section 11**.

5.6.1 Non-Stormwater Outfall-Based Monitoring Sites

The Outfall Screening and prioritization processes will result in an inventory of outfalls that are required to be monitored per the Permit requirements. The information to determine the number and location of outfalls requiring monitoring will be available after the screening is completed.

5.6.2 Monitored Parameters and Frequency of Monitoring

Part IX.G.2-4 of the MRP specifies the following monitoring frequency for NSW outfall monitoring:

1. For outfalls subject to a dry weather TMDL, the monitoring frequency shall be per the approved TMDL monitoring plan or as otherwise specified in the TMDL or as specified in an approved CIMP.
2. For outfalls not subject to dry weather TMDLs, four times per year approximately quarterly for first year.
3. Monitoring can be eliminated or reduced to twice per year, beginning in the second year of monitoring if pollutant concentrations measured during the first year do not exceed WQBELs, NSW Action Levels, or water quality standards for pollutants identified on the 303(d) List.

An alternative frequency is proposed to integrate the approach to screening and identification of significant NSW discharges with the LAR Bacteria TMDL outfall monitoring requirements. The frequency of the LAR Bacteria TMDL outfall monitoring is six times prior to implementation of actions. As such, the frequency of sample collection for the screening and monitoring events are as follows:

- **Screening:** Sample collection will be conducted **three** times at all flowing storm drains to meet the LA River Bacteria TMDL LRS monitoring requirements and establish the outfalls with significant NSW discharges.
- **Monitoring:** Sample collection will be conducted **three** times as follows:
 - *E. coli* will be monitored at all flowing storm drains to meet the LA River Bacteria TMDL LRS monitoring requirements.
 - Constituents required to meet the MRP requirements will be monitored at the subset of outfalls determined to be significant NSW discharges.

After the completion of the three monitoring events, *E. coli* monitoring at all flowing storm drains will be considered completed and will not be initiated again until implementation associated with that waterbody has been completed consistent with the LA River Bacteria TMDL schedule. Monitoring at outfalls with significant NSW discharges will be re-evaluated consistent with the Permit requirements on page E-28 of the MRP. **Section 13** summarizes the timing of initiating the screening and monitoring events for each LA River segment and tributary.

The requirements for constituents to be monitored are outlined in the Part IX.G.1.a-e of the MRP. Outfalls will initially be monitored for all required constituents except toxicity. Toxicity monitoring will occur when triggered by receiving water toxicity monitoring and TIE results. An overview of the constituents required in the MRP for NSW monitoring is listed in **Table 19**. This list was generated from the current list of constituents monitored during dry weather in the receiving waters and will be updated as the constituents monitored during dry weather in the waterbody to which they discharge, as well as downstream waterbodies, are updated and/or based upon the data collected at the individual outfall site. To be consistent with receiving water monitoring, NSW monitoring will consist of collecting grab samples. Note that constituents associated with suspended sediments transported during wet weather (i.e., PCBs, DDTs, dieldrin, chlordane, and PAHs) and which have also either not exceeded (i.e., PCBs, dieldrin, and chlordane) or have not regularly exceeded (i.e., DDTs and PAHs) in receiving waters are not included in the list of constituents presented in **Table 19** (see Section 3 of **Attachment A**). However, **Table 19** will be updated as the constituents monitored during dry weather in the waterbody to which they discharge, as well as downstream waterbodies, are updated.

Analytical methods, detection limits, sampling methods, and sample handling procedures are detailed in **Attachment C**. In addition, details regarding the collection of QA/QC samples are outlined in **Attachment C**.

Table 19. List of NSW Outfall Monitoring Parameters⁽¹⁾

Parameters	Subwatershed ⁽²⁾										
	Reach 2	Reach 3	Reach 4	Reach 5	Reach 6	CC	RH	AS	VW	BWC	TW
Flow, hardness, pH, dissolved oxygen, temperature, and specific conductivity	X	X	X	X	X	X	X	X	X	X	X
TSS	X	X	X	X	X	X	X	X	X	X	X
Table E-2 pollutants detected above relevant objectives	X	X	X	X	X	X	X	X	X	X	X
<i>E. Coli</i>	X	X	X	X	X	X	X	X	X	X	X
Copper (total and dissolved)	X	X	X	X	X	X	X	X	X	X	X
Lead (total and dissolved)	X	X	X	X	X	X	X	X	X	X	X
Zinc (total and dissolved)	X	X	X	X	X	X	X	X	X	X	X
Selenium (total)					X						
Mercury (total)	X	X	X	X	X	X	X	X	X	X	X
Bis(2-ethylhexyl)Phthalate					X		X	X		X	
2,3,7,8-TCDD (Dioxin)		X	X	X	X				X	X	X
Diazinon			X	X	X		X				X
Cyanide (total)							X				
Chloride				X	X	X	X			X	X
Sulfate			X	X	X						X
TDS				X	X					X	X
Chlorpyrifos						X					

1. As described in **Section 11**, data collected as part of the ULARWMAG CIMP will be reviewed and changes to the constituents and frequencies as a result of exceedances in the receiving waters or as a result of toxicity testing will be discussed in the annual report and implemented starting no later than the first CIMP event of the next monitoring year (i.e., the first event after July 1 of the year following the annual report submittal).
2. CC (Compton Creek), RH (Rio Hondo), AS (Arroyo Seco), VW (Verdugo Wash), BWC (Burbank Western Channel), and TW(Tujunga Wash)

5.7 NON-STORMWATER OUTFALL MONITORING SUMMARY

A summary of how the NSW outfall monitoring program meets the intended objectives of the NSW outfall monitoring program outlined in Part II.E.3 of the MRP is presented in **Table 20**. The schedule for implementing the NSW Outfall Monitoring Program is presented in **Section 13**.

Table 20. Summary of NSW Outfall Monitoring Program Objectives

MRP Objective	CIMP Component Meeting Objective
Determine whether a Permittee's discharge is in compliance with applicable NSW WQBELs derived from TMDL WLAs	<ul style="list-style-type: none"> List of constituents based on the water quality priorities which incorporate constituents with WQBELs derived from TMDL WLAs and considers current and historical exceedances in receiving waters. When implementing the NSW Outfall Program, <i>E. coli</i> is used when determining the significance of a NSW discharge because, of the constituents addressed by TMDLs for which WQBELs and RWLs were incorporated into the Permit, <i>E. coli</i> consistently exceeds RWLs and all other TMDL-related WQBELs and RWLs either consistently meet the dry weather RWLs or are primarily associated with wet weather discharges.
Determine whether a Permittee's discharge exceeds NSW action levels, as described in Attachment G of the MS4 Permit.	<ul style="list-style-type: none"> Extensive list of constituents being collectively monitored at NSW outfall monitoring sites.
Determine whether a Permittee's discharge causes or contributes to an exceedance of RWLs.	<ul style="list-style-type: none"> List of constituents based on the monitoring requirements of the waterbody to which they discharge, as well as downstream waterbodies.
Assist a Permittee in identifying illicit discharges as described in Part VI.D.10 of the MS4 Permit.	<ul style="list-style-type: none"> NSW Outfall Program is designed to be complimentary to IC/ID program. NSW Outfall Program provides a mechanism for the detection, identification, and elimination of illicit discharges. Where NSW discharges are deemed "significant", the NSW Outfall Program will discern whether the discharges are illicit, exempt, or conditionally exempt. If the source identification component of the NSW Outfall Program determines a discharge to be an illicit discharge, the discharge will be referred to the IC/ID program.

6 Trash Monitoring

The monitoring and reporting requirements of the LAR Trash TMDL are unique when compared with other components of this CIMP. Compliance with the LAR Trash TMDL is being met by the following ULARWMAG members through the installation of full capture devices: County of Los Angeles and cities of Burbank, Calabasas, Glendale, La Cañada Flintridge, Los Angeles, Montebello, Pasadena, Rosemead, San Fernando, San Gabriel, and South El Monte. As such, no specific monitoring is required or will be conducted for the LAR Trash TMDL by these ULARWMAG members.

Compliance with the LAR Trash TMDL is being met by the following ULARWMAG members through a combination of full capture, partial capture, and/or institutional controls: cities of Alhambra, Hidden Hills, Monterey Park, Rosemead, San Marino, South Pasadena, and Temple City. As such, these ULARWMAG members are required to conduct monitoring necessary to estimate a storm event discharge through use of a daily generation rate (DGR). Details on how these ULARWMAG members will conduct the necessary monitoring are presented in **Attachment C**.

The full capture approach is also being implemented within the drainage area of Echo Park Lake, thereby addressing the requirements of the Echo Park Lake Trash TMDL, including the monitoring requirements.

The City of South El Monte, County of Los Angeles, and LACFCD are monitoring Legg Lake under an approved Minimum Frequency of Collection and Assessment (MFAC) Program, which will continue as part of this CIMP, with the modification of reducing the frequency of photographic documentation and forms to a monthly frequency consistent with a letter dated April 16, 2014 from the Regional Board Executive Officer to the County of Los Angeles Parks and Recreation. Additional details regarding the necessary monitoring are presented in **Attachment C**.

7 New Development/Re-Development Effectiveness Tracking

ULARWMAG members are required to maintain databases to track specific information related to new and redevelopment projects subject to the MCM in Part VI.D.7. The specific data to be tracked is listed in Part X.A of the MRP (**Table 21**). The data will be used to assess the effectiveness of the LID requirements for land development and to fulfill reporting requirements. Although the data requirements are clear, the procedures for reviewing projects, tracking data, and reporting are different for each jurisdiction and may even be different across departments within the same jurisdiction. Due to the complexity of land development processes across jurisdictions, data management and tracking procedures will vary by jurisdiction. As such, the following subsections generally detail the requirements and approaches related to the new and redevelopment tracking requirements. Specifics are available from each ULARWMAG member.

Table 21. Required Data to Track for New and Redevelopment Projects per Part X.A of the MRP

✓ Name of the Project	✓ Project design storm volume (gallons or million gallons per day)
✓ Name of the Developer	✓ Percent of design storm volume to be retained onsite
✓ Project location and map ¹	✓ Design volume for water quality mitigation treatment BMPs (if any)
✓ Documentation of issuance of requirements to the developer	✓ One year, one hour storm intensity ² (if flow through treatment BMPs are approved)
✓ 85 th percentile storm event for the project design (inches per 24 hours)	✓ Percent of design storm volume to be infiltrated at an offsite mitigation or groundwater replenishment site
✓ 95 th percentile storm event for projects draining to natural water bodies (inches per 24 hours)	✓ Percent of design storm volume to be retained or treated with biofiltration at an offsite retrofit project
✓ Other design criteria required to meet hydromodification requirements for drainages to natural water bodies	✓ Location and maps of offsite mitigation, groundwater replenishment, or retrofit sites ¹
✓ Project design storm (inches per 24 hours)	✓ Date of Certificate of Occupancy

1. Preferably linked to the GIS Storm Drain Map

2. As depicted on the most recently issued isohyetal map published by the Los Angeles County hydrologist

The Standard Urban Stormwater Mitigation Program (SUSMP) requirements implemented under the previous MS4 Permit (Order R4-01-182) laid the foundation for the MCMs contained in Part VI.D.7 of the current MS4 Permit. With implementation of the SUSMP, Permittees required post construction BMPs on applicable projects, developed standard requirements for project submittals, and began to track related data. The Permittees will build on the existing procedures for land development to ensure that all required project data is captured.

To meet the requirements of the Permit, internal procedures and data protocols that clearly define departmental roles and responsibilities pertaining to data collection, data management, and tracking will be utilized. These procedures will include points in the process where data are generated and tracked, who is responsible for tracking the data, and how the data will be

managed. Data management protocols and internal procedures, will also consider the land development data tracking requirements contained in Part VI.D.7.d.iv.(1)(a). These requirements are distinct from those listed in the MRP but will be addressed similarly. Data requirements under Part VI.D are contained in **Table 22**.

Table 22. Required Data to Track for New and Redevelopment Projects per Part VI.D.7.d.iv.(1)(a)

✓ Municipal Project ID	✓ Maintenance Records
✓ State Waste Discharge Identification Number	✓ Inspection Date(s)
✓ Project Acreage	✓ Inspection Summary(ies)
✓ BMP Type and Description	✓ Corrective Action(s)
✓ BMP Location (coordinates)	✓ Date Certificate of Occupancy Issued
✓ Date of Acceptance	✓ Replacement or Repair Date
✓ Date of Maintenance Agreement	

8 Regional Studies

Only one regional study is identified in the MRP: Southern California SMC. The Southern California SMC is a collaborative effort between all of the Phase I MS4 NPDES Permittees and NPDES regulatory agencies in Southern California. SCCWRP oversees the management and implementation of the SMC.

The goal of the SMC is to develop technical information necessary to better understand stormwater mechanisms and impacts, and develop tools to effectively and efficiently improve stormwater decision-making. One program initiated under the SMC is a Regionally Consistent and Integrated Freshwater Stream Bioassessment Monitoring Program (Bioassessment Program). The SMC initiated the Bioassessment Program in 2009. The bioassessments are structured to occur in cycles of five years. Sampling under the first cycle concluded in 2013. The next five-year cycle is scheduled to begin in 2015, with additional special study monitoring scheduled to occur in 2014.

The MRP states that each Permittee shall be responsible for supporting the monitoring described at the sites within the watershed management area(s) that overlap with the Permittee's jurisdictional area. Specifically, for the Bioassessment Program of the SMC, the LACFCD and City of Los Angeles will continue their participation in the SMC Regional Bioassessment Monitoring Program on behalf of the ULARWMAG during the current Permit term. LACFCD and City of Los Angeles's participation will address the MRP requirements as well as monitoring related to macrobenthic invertebrate 303(d) listings in the ULAR EWMP area. SMC, including LACFCD and the City of Los Angeles, are currently working on designing the bioassessment monitoring program for the next five-year cycle, which is scheduled to run from 2015 to 2019.

9 Special Studies

The MRP states that each Permittee is responsible for conducting special studies required in an effective TMDL or an approved TMDL Monitoring Plan. The effective TMDLs, revised TMDLs, and approved Monitoring Plans relevant to the ULARWMAG EWMP area do not require the completion of special studies. Special studies may be identified in the future and may either rely upon data collected through this CIMP or may be developed through a separate process.

10 Non-Direct Measurements

Environmental data (water, sediment, and tissue data) collected through other monitoring programs (e.g., WRPs, downstream CIMP, Council for Watershed Health) in the LAR watershed will be incorporated to the extent practicable. The extent practicable will be dictated by the cost of gathering and compiling information from outside programs. It is not the intent or purpose of this CIMP to compile and analyze all available data. Environmental data reported by other entities will be evaluated for suitability for inclusion in this CIMP database and will be accepted if the data meet the following requirements:

- Conducted and documented consistent with the sampling procedures outlined in this CIMP.
- Sample collection is performed and documented by a competent party consistent with applicable guidance and this CIMP.
- Sample analysis is conducted using analytical methods equivalent to those identified in **Section 9** of **Attachment B** by a certified analytical laboratory.
- Sample collection occurs at an appropriate location to meet the objectives of the MS4 monitoring program as set forth in Attachment E, Parts II.A and II.E.

As described in **Section 2**, receiving water monitoring sites may be moved to allow for improved coordination between this CIMP and WRP receiving water monitoring programs. If the specified sites are moved and the suitability requirements are met, environmental data collected by the WRPs may be directly used in place of the monitoring described in this CIMP.

Regardless of whether monitoring sites are moved, several instances have been identified where environmental data collected by the WRPs will be directly used by the ULARWMAG. These instances are denoted in **Table 5** and **Table 6**. Receiving water monitoring data collected by the applicable WRP will be obtained from each agency responsible for conducting such monitoring and reported as described in **Attachment D**. If WRP monitoring frequency is reduced below the frequency needed to meet the requirements of the MRP, this CIMP will be revised to conduct the monitoring.

Due to the absence of previously collected monitoring results, an understanding has not been obtained of the extent to which pollutants associated with suspended sediment being discharged from the MS4 are causing or contributing to the impairments identified in the Harbor Toxics TMDL. As such, to gain a clear understanding, environmental data representative of the entire Los Angeles River WMA will be collected downstream of the ULARWMAG EWMP area and directly used for suspended sediment monitoring associated with meeting the requirements of the Harbor Toxics TMDL. The LLAR WMP Group will conduct suspended sediment monitoring associated with meeting the requirements of the Harbor Toxics TMDL. The suspended sediment monitoring data associated with meeting the requirements of the Harbor Toxics TMDL will be obtained from the LLAR WMP Group and reported as described in **Attachment D**. As further described in **Section 11.2**, after a better understanding has been obtained of the extent to which pollutants associated with suspended sediment being discharged from the MS4 are causing or contributing to the impairments identified in the Harbor Toxics TMDL, the ULARWMAG may elect to also conduct suspended sediment monitoring associated with meeting the requirements

of the Harbor Toxics TMDL at the LAR_02_WAS LTA site to assess the ULARWMAG's load to downstream waterbodies.

Non-direct measurements of flow and rainfall information will be obtained from the LACDPW as described in **Attachment C**.

11 Adaptive Management

The adaptive management process will be utilized on an annual basis to evaluate this CIMP and update the monitoring requirements as necessary. As noted in this CIMP, several monitoring elements are dynamic and may require modifications to the monitoring sites, schedule, frequency or parameters. In particular, the NSW screening program and the toxicity monitoring will likely generate changes that need to be incorporated. This section lays out a range of possible modifications to this CIMP and the process for CIMP revision and update.

11.1 INTEGRATED MONITORING AND ASSESSMENT PROGRAM

This CIMP is based on the MRP requirements and analysis of existing data. As monitoring occurs, additional information will be gathered that will require modifications to this CIMP. Every year, an evaluation will be conducted to identify potential modifications resulting from the following:

- TIEs result in the identification of additional constituents that need to be monitored.
- Additional upstream receiving water monitoring is necessary to characterize the spatial extent of RWL exceedances.
- Additional outfall monitoring is needed in response to RWL exceedances.
- NSW outfall sites will change as discharges are addressed.
- Monitoring data demonstrates that water quality objectives are not being exceeded in the receiving waters.
- Source investigations determine that MS4 discharges are not a source of a constituent.

The results from the monitoring are meant to tie into the EWMP as feedback for the water quality changes resulting from control measures implemented by the ULARWMAG. As a result, additional changes may be considered during the evaluation based on the control measure implementation needs.

11.2 CIMP REVISION PROCESS

This CIMP identifies a range of sampling that will likely result in data that will require changes to ensure monitoring meets the requirements and intent of the MRP and supports EWMP implementation. However, since many of those potential changes are identified in this CIMP, it should not be necessary to obtain Regional Board approval of modifications already considered in this CIMP to ensure timely implementation of appropriate modifications to monitoring. These changes are outlined in this section. Changes identified in this section will be discussed in the annual report and implemented starting no later than the first CIMP monitoring event of the next monitoring year (i.e., the first event after July 1 of the year following the annual report submittal), including:

1. Adding constituents (including but not limited to those which meet the activation criteria described in **Section 2.2**) at receiving water and/or outfall monitoring sites, increasing monitoring frequency, or adding sites as a result of requirements in the MRP (e.g., TIE results), procedures outlined in this CIMP or to further support meeting the monitoring objectives.

2. Discontinuing monitoring for Table E-2 constituents that are not identified as a water quality priority and are not detected at levels above relevant water quality objectives in the first year of monitoring.
3. Modifying methods for consistency with USEPA method requirements or to achieve lower detection limits.
4. Changing analytical laboratories.
5. Relocating an outfall monitoring location determined to be not representative of MS4 discharges in the ULARWMAG EWMP area (for reasons other than the observed water quality) or because monitoring at the site is not feasible to its alternate outfall site in the subwatershed as identified in **Attachment B**.
6. Implementing the changes associated with conducting at least one re-assessment of the NSW Outfall Program during the Permit term.
7. Modifications to sampling protocols resulting from coordination with other watershed monitoring programs. In particular, as described in **Section 10**, suspended sediment monitoring associated with meeting the requirements of the Harbor Toxics TMDL will be conducted downstream of the ULARWMAG EWMP area. If consistent exceedances (i.e., exceedances which occur at a frequency greater than the activation criteria described in **Section 2.2**) of interim WQBELs are observed and the ULARWMAG determines that control measures will need to be implemented to meet the final WQBELs by March 23, 2032, the ULARWMAG will commence monitoring at the LAR_02_WAS LTA site to assess the degree to which discharges from the ULARWMAG EWMP area are causing or contributing to those exceedances. If there are two consecutive monitoring events with exceedances observed (i.e. one or more constituents meet the activation criteria described in **Section 2.2**), the ULARWMAG will commence monitoring at the stormwater outfall monitoring sites to assess the degree to which discharges from each ULARWMAG member may be causing or contributing to those exceedances. If triggered, stormwater outfall monitoring for these constituents will commence no later than the first stormwater outfall monitoring event of the 2028/2029 wet season, which allows adequate time to implement additional control measures, if necessary, prior to the final TMDL compliance deadline.

The following modifications or adjustments to the monitoring program may be proposed by the ULARWMAG to the Regional Board. These modifications will be proposed by the ULARWMAG via a letter to the Regional Board and may be subject to approval by the Executive Officer of the Regional Board. Approval by the Executive Officer of the Regional Board will be assumed unless written disapproval is received within 90 days of the date the ULARWMAG submitted the letter containing the ULARWMAG's request(s) to the Regional Board.

1. Discontinuing monitoring of any non-TMDL constituent at a specified site if there are two consecutive monitoring events for the same condition (i.e., wet or dry weather) with no exceedances observed (i.e., constituents which meet the deactivation criteria described in **Section 2.2**).
2. Relocating an outfall monitoring location determined to be not representative of MS4 discharges in the ULARWMAG EWMP area (for reasons other than the observed water quality) or because monitoring at the site is not feasible to an outfall monitoring location other than the predetermined alternative outfall site.

Should additional modifications be identified that are not specified in this section that would be major changes to the approach, the modifications will be proposed in the annual report and in a separate letter to the Regional Board requesting Executive Officer approval of the change. Upon receipt of written approval from the Executive Officer, this CIMP will be updated and a revised CIMP will be provided to the Regional Board.

12 Data Management and Reporting

Attachment D details the procedures for managing and reporting data to meet the goals and objectives of this CIMP and the Permit. The details contained in **Attachment D** serve as a guide for ensuring that consistent protocols and procedures are in place for successful data management and reporting. Data management procedures include data review, verification, and validation.

Annual monitoring reports are required to be submitted by December 15 of each year. The annual monitoring reports will cover the monitoring period of July 1 through June 30. The annual monitoring reports will include the following:

- Watershed Summary Information
 - Watershed Management Area
 - Subwatershed (HUC-12) Descriptions
 - Description of Permittee(s) Drainage Area within the Subwatershed
- Annual Assessment and Reporting
 - Stormwater Control Measures
 - Effectiveness Assessment of Stormwater Control Measures
 - Non-stormwater Water Control Measures
 - Effectiveness Assessment of Non-Stormwater Control Measures
 - Integrated Monitoring Compliance Report
 - Adaptive Management Strategies
 - Supporting Data and Information.

Additionally, analytical data reports are required to be submitted on a semi-annual basis and will include the following:

- Exceedances applicable to WQBELs, RWLs, action levels, or aquatic toxicity thresholds.
- Corresponding sample dates and monitoring locations.

Semi-annual data reports will be submitted with the annual report and six months prior to the annual report (June of each year). The mid-year data reports will cover the monitoring period of July 1 through December 31.

Furthermore, if any of the authorized or conditionally exempt essential NSW discharges are determined to be a source of pollutants that causes or contributes to an exceedance of applicable RWLs and/or WQBELs, Part III.A.4.e of the Permit requires that the Regional Board be notified within 30 days if the NSW discharge is an authorized discharge with coverage under a separate NPDES permit or authorized by USEPA under CERCLA, or a conditionally exempt essential NSW discharge or emergency NSW discharge.

Details on the reporting requirements from the MRP that will be submitted with the semi-annual analytical data reports and annual monitoring reports are presented in **Attachment D**. In addition to the requirements from the MRP, a discussion of how the reported data are to be used is included in **Attachment D**.

13 Schedule for CIMP Implementation

Per the MRP, monitoring shall commence within 90 days after approval of this CIMP by the Executive Officer of the Regional Board. Implementation of all components of this CIMP will commence prior to or within 90 days of approval, except for new and redevelopment effectiveness tracking which will begin no later than the submittal of the Draft EWMP (June 28, 2015).

The status of implementation of the various components will vary based on the current status of implementation and the feasibility of collecting a sample within 90 days after approval of this CIMP (e.g., stormwater outfall monitoring). During the CIMP approval process all existing monitoring will continue. Within 90 days of CIMP approval, sample collection for all constituents at all dry weather receiving water sites and all constituents at all existing wet weather receiving water sites will commence. The remaining monitoring will be affected by the feasibility of collecting a sample within 90 days of CIMP approval. The two primary factors affecting the feasibility of sample collection upon approval of this CIMP relate to (1) autosampler installation and (2) monitoring that is dependent upon prerequisite information (e.g., monitoring of significant NSW discharges).

Autosamplers are used to characterize the water quality of a storm event. Receiving water wet weather samples and stormwater outfall samples will generally be collected as composite samples. As such, the installation of an autosampler is necessary before monitoring can commence. Given the continued use of previously monitored receiving water sites in LAR Reach 3 at Figueroa St, LAR Reach 4 at Tujunga Ave, and LAR Reach 6 at White Oak Avenue, existing autosampling equipment can be utilized to conduct receiving water monitoring at these sites within 90 days of approval of this CIMP for constituents that were monitored prior to development of this CIMP and those newly identified for monitoring during CIMP development. However, given the addition of a receiving water wet weather monitoring site in LAR Reach 2 at Washington Blvd, an autosampler will likely need to be installed at the LAR_02_WAS receiving water site before wet weather monitoring can commence. Similarly, an autosampler will likely be installed at each of the 12 stormwater outfall monitoring sites before stormwater outfall monitoring can commence.

The process for installing autosamplers includes numerous tasks that require multiple agency coordination and permitting. Numerous autosampler stations have been installed throughout the County and provide significant experience in understanding the challenges and timelines for designing, permitting, and installing autosampler stations. The following provides an overview of the tasks and timelines associated with autosampler installation and **Figure 6** presents a graphical representation of what would be considered a relatively straightforward installation timeframe:

- Detailed autosampler site configuration/design, which includes data collection and review, identification of permit requirements, concept design, development of summary technical memos, and review by participating agencies and associated divisions: **12 months**

- Obtaining permits from one or more of the following entities: Army Corps of Engineers, LACFCD, US Fish and Wildlife Service, CA Department of Fish and Game, CA Coastal Commission, and the Regional Board: **3 to 10 months**
- Purchase of equipment via contractor or via agency procurement process (can occur somewhat concurrently with permitting): **2 to 6 months**
- Connecting to power via an upgrade to existing service or establishing new service: **1 to 6 months**
- Construction of monitoring station assuming no bid/award process: **1 month**
- Total time: **18 to 30 months**

To account for the time required for autosampler installation, a phased approach to sampling will be conducted for the wet weather receiving water and stormwater outfall elements of this CIMP (**Figure 5**). To meet the aggressive installation schedule presented in **Figure 5**, the ULARWMAG has already begun a few of the tasks associated with autosampler installation for select sites. Phasing in the receiving water and stormwater outfall elements of this CIMP will allow evaluation of the sites to determine if any need to be changed due to significant contributions from non-MS4 sources or other reasons that sampling is not feasible at a site and one of the alternate or a new site must be utilized.

- Phase I of CIMP implementation will commence in October 2015. Phase I receiving water monitoring will consist of **all** monitoring other than wet weather monitoring conducted at the LAR_02_WAS monitoring site due to the need to install an autosampler. Phase I stormwater outfall monitoring will consist of 1) monitoring conducted at LAR_03_SW_COL, RH_SW_ROB, and AS_SW_SEC and 2) the continuation of the autosampler installation process at the remaining monitoring sites. The primary challenges experienced during previous autosampler installation processes are permitting by non-ULARWMAG members (i.e., US Army Corps of Engineers) and establishment of power connections. In extreme cases, these challenges have caused the installation of equipment to take 36 months. However, the typical installation timeframe for conditions similar to the ULAR EWMP area is 18 to 24 months.
- Phase II will commence in October 2016 to allow sufficient time for autosampler installation to be completed as detailed in **Figure 6**. Phase II (and all subsequent phases) receiving water monitoring will consist of the monitoring conducted during Phase I and the addition of wet weather monitoring conducted at the newly installed LAR_02_WAS monitoring site. Phase II stormwater outfall monitoring will consist of 1) monitoring conducted at LAR_06_SW_OLD, VW_SW_CAN, and TW_SW_BUR and 2) the continuation of the autosampler installation process at the remaining monitoring sites.
- Phase III will commence in October 2017 to allow sufficient time for the installation of an additional three autosamplers. Phase III (and all subsequent phases) stormwater outfall monitoring will consist of the monitoring conducted during Phase II and the addition of 1) stormwater outfall monitoring at CC_SW_LAN, RH_SW_LER, and BWC_SW_MAI and 2) the continuation of the autosampler installation process at the remaining monitoring sites.
- Phase IV will commence in October 2018 to allow sufficient time for the installation of the final three autosamplers. Phase IV stormwater outfall monitoring will consist of the

monitoring conducted previously and the final three newly installed monitoring sites (LAR_02_SW_MAI, LAR_04_SW_BUE, and LAR_06_SW_WIN).

As described in **Section 5**, the NSW Outfall Program consists of a process which consists of six elements which occur sequentially:

1. Outfall Screening
2. Identification of outfalls with significant NSW discharge
3. Inventory of outfalls with significant NSW discharge
4. Prioritized source investigation
5. Identify sources of significant NSW discharge
6. Monitoring significant NSW discharges exceeding criteria

To account for the time required to complete all six steps of the NSW Outfall Program, a phased approach to sampling as outlined in the MRP will be conducted for the NSW outfall elements of this CIMP. Phasing in the NSW outfall elements of this CIMP will provide the time necessary to complete each element of the NSW Outfall Program. As described in **Section 5.1**, the LAR Bacteria TMDL provides a phased approach to implementation that forms the basis of phasing the implementation of the NSW Outfall Program in this CIMP, which is appropriate given the size of the ULARWMAG EWMP area. The phasing of the approach follows the prioritization of LA River segments and tributaries utilized in the TMDL and incorporated into the Permit. Furthermore, as described in **Section 5.6.2**, the frequency of the LAR Bacteria TMDL outfall monitoring is six times prior to implementation of actions. As such, the first three LAR Bacteria TMDL monitoring events will be used to complete the Outfall Screening process and the final three LAR Bacteria TMDL monitoring events will be used to monitor significant NSW discharges exceeding criteria. **Figure 7** summarizes the timing of initiating the screening and monitoring events for each LA River segment and tributary.

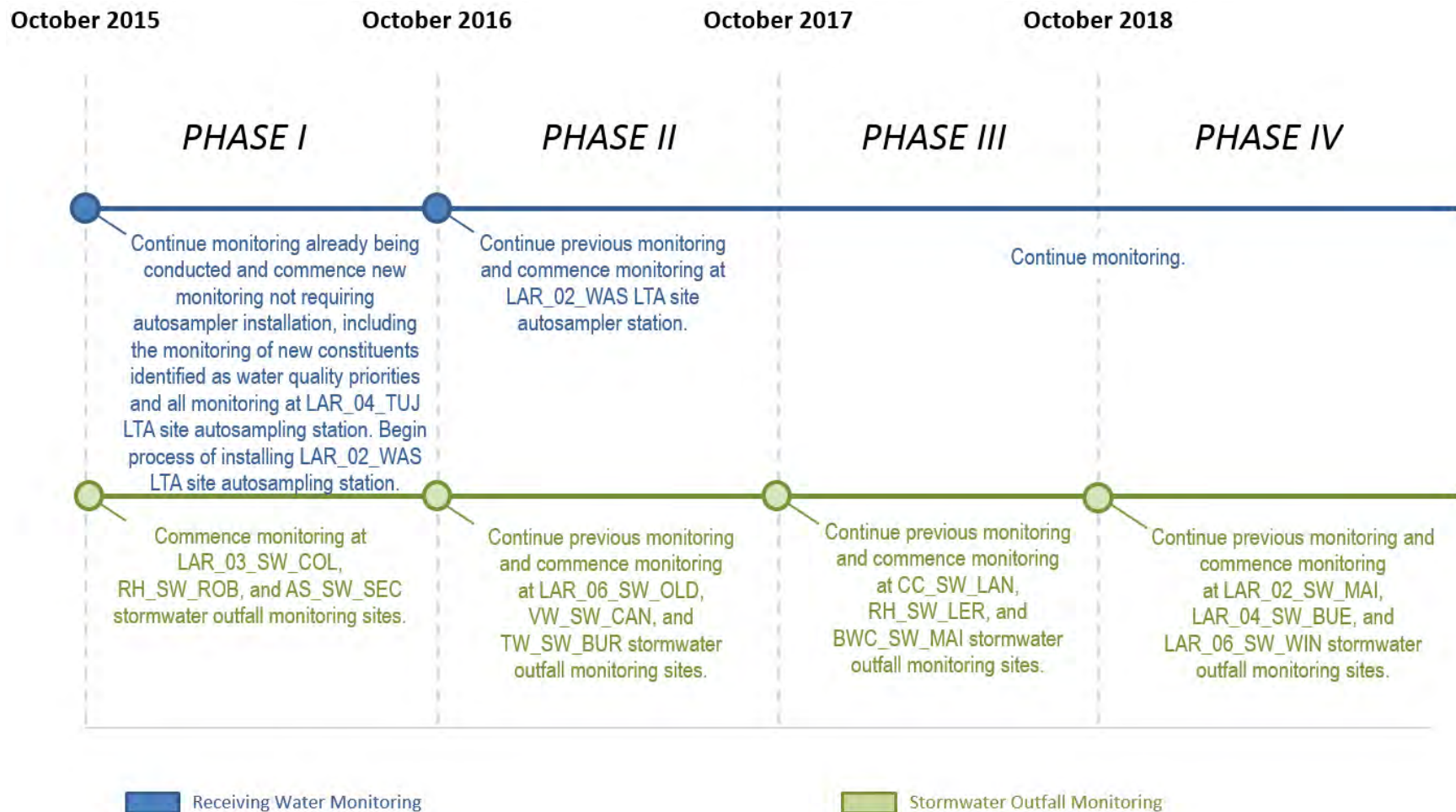

Figure 5. Implementation Schedule for Major CIMP Elements

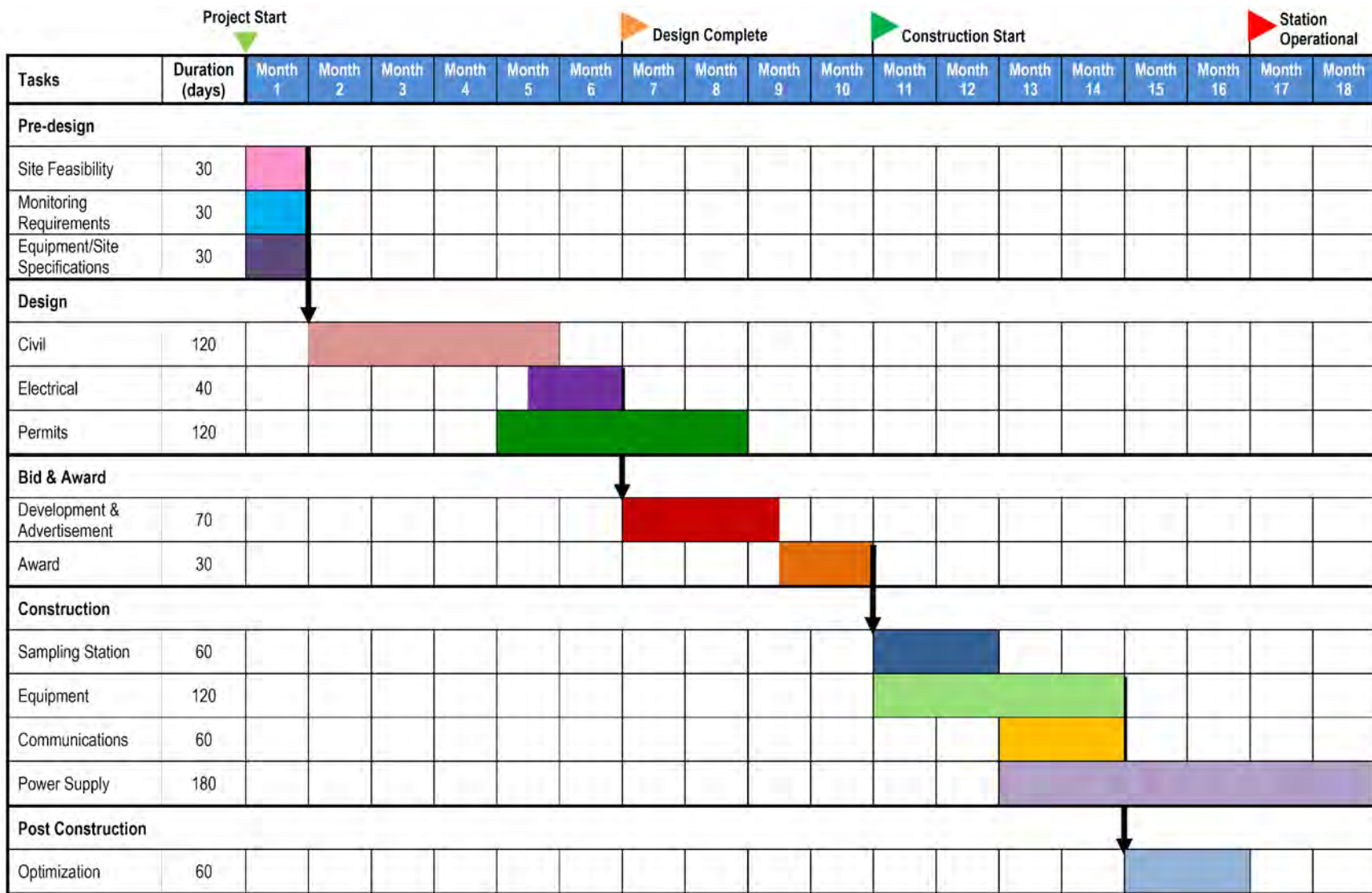

Figure 6. Typical Duration for the Establishment of a New Sampling Station Assuming a Streamlined Process

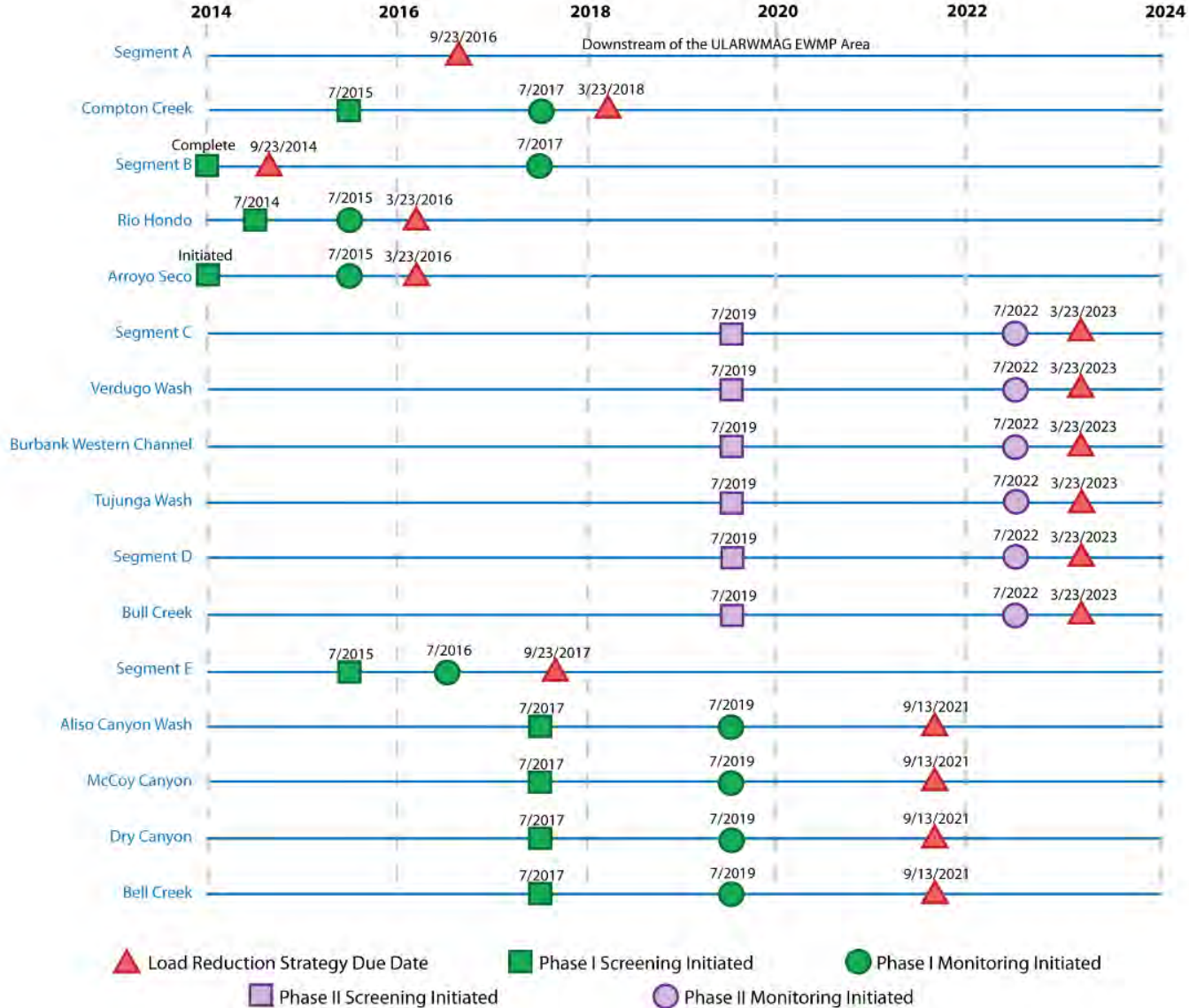

Figure 7. Summary of Phased Screening and Monitoring Initiation Dates Consistent with the LAR Bacteria TMDL Load Reduction Strategy (LRS) Requirements

14 References

Cleaner Rivers Through Effective Stakeholder TMDLs (CREST). 2008. Los Angeles River Bacteriological Source Identification Study. Final Report.

County of Los Angeles Department of Public Works, City of Los Angeles WPD, and City of Calabasas. 2005. *Monitoring Work Plan to Assess Nutrients Loading from the Municipal Separate Storm Sewer System in Los Angeles River Watershed*. March 2005.

Los Angeles River Metals TMDL Technical Committee. 2008. *Los Angeles River Metals TMDL Coordinated Monitoring Plan*. Chaired by the City and County of Los Angeles. March 25, 2008.

Los Angeles River Watershed Bacteria TMDL Technical Committee. 2013. *Coordinated Monitoring Plan for Los Angeles River Watershed Bacteria TMDL – Compliance Monitoring*. Chaired by the City of Los Angeles. March 23, 2013.

Legg Lake Trash TMDL Jurisdictional Group. 2008. *Trash Monitoring & Reporting Plan: Legg Lake Trash TMDL*. September 5, 2008.

Coordinated Integrated Monitoring Program (CIMP) Attachments and Appendices

for the Upper Los Angeles River Watershed

Prepared for

Upper Los Angeles River Watershed Management Group



Preparation Lead



In Conjunction with the Black & Veatch Team

CH2M HILL

Paradigm Environmental

List of Attachments

Attachment A: Enhanced Watershed Management Plan Area Background.....	1
1 Existing Monitoring Programs.....	1
2 TMDL Monitoring Requirements.....	11
3 Water Quality Priorities	18
4 LACFCD Background Information	44
5 Watershed Background References	46
Attachment B. Monitoring Location Fact Sheets.....	47
6 Receiving Water Sites.....	47
7 Stormwater Outfall Sites.....	70
8 Monitoring Location References	109
Attachment C. Analytical and Monitoring Procedures.....	110
9 Analytical Procedures	110
10 Sampling Methods and Sample Handling.....	131
11 Quality Control Sample Collection.....	164
12 Instrument/Equipment Calibration and Frequency.....	169
13 Monitoring Procedures References.....	169
Attachment D. Data Management and Reporting	172
14 Data Management, Validation, and Usability.....	172
15 Reporting.....	174

List of Appendices

- Appendix 1: Example Field, Calibration and Chain-of-Custody Forms
- Appendix 2: Trash Monitoring & Reporting Plan: Legg Lake Trash TMDL
- Appendix 3: Calculations for Data Quality Assessment
- Appendix 4: Chapter 13 QA/QC Data Evaluation from Caltrans Guidance Manual: Stormwater Monitoring Protocols, 2nd Edition

Attachment A: Enhanced Watershed Management Plan Area Background

Attachment A summarizes background information on the area addressed by the Coordinated Integrated Monitoring Program (CIMP) that was utilized to support development of the various monitoring components. **Attachment A** is divided into the following sections:

- Existing Monitoring Programs
- TMDL Monitoring Requirements
- Water Quality Priorities

1 Existing Monitoring Programs

Existing watershed monitoring programs provide historical data and information that were used to support site selection and identification of constituents for monitoring. The following subsections briefly describe the current state of existing monitoring programs relevant to the Upper Los Angeles River Watershed Management Area Group (ULARWMAG).

1.1 MS4 Permit Monitoring (Mass Emission and Tributary Monitoring)

Downstream of the Enhanced Watershed Management Program (EWMP) area, one mass emission station has been monitored to meet the requirements of the previous municipal separate storm sewer (MS4) Permits. The Los Angeles River (LAR or LA River) Mass Emission Station, S10, is located at the existing stream gauging station (Stream Gauge No. F319-R) between Willow Street and Wardlow Road in the City of Long Beach (**Figure 1**). The upstream tributary area is 825 square miles. The station was chosen to avoid tidal influences. Agencies not participating in the ULARWMA EWMP and open space contribute a significant amount of runoff that flows to S10. In addition to the mass emission station, six tributary monitoring stations located within the ULARWMA Group jurisdictions have also been monitored. The six tributary sites established under the 2001 MS4 Permit were monitored during the 2003-04 wet season during dry and wet weather. The six tributary monitoring stations, all of which receive runoff from non-MS4 sources, are:

- Aliso Canyon Wash (TS01): located near the Saticoy Street Bridge in Reseda, the upstream tributary area draining to this site is 21 square miles.
- Bull Creek (TS02): located near the Victory Boulevard Bridge in Lake Balboa, the upstream tributary area draining to this site is 23 square miles.
- Burbank Western Channel (TS03): located near the Riverside Drive Bridge in Glendale at the same location as stream gaging station E285-R, the upstream tributary watershed of the Burbank Western Channel is approximately 26 square miles.
- Verdugo Wash (TS04): located approximately 100 feet downstream of the Jackson Street Bridge in the City of Glendale, the upstream tributary area draining to this site is approximately 30 square miles.
- Arroyo Seco (TS05): located approximately a quarter mile downstream of the Avenue 52

Bridge in the City of Los Angeles, the upstream tributary area draining to this site is approximately 47 square miles.

- Rio Hondo (TS06): located at Beverly Boulevard, downstream of Whittier Narrows Dam, at the United States Geographical Society (USGS) – USACE stream gauge (Stream Gauge No. 1102300 or E327-R), the upstream tributary area is approximately 142 square miles.

To meet the monitoring requirements for these sites in the previous MS4 Permit, wet weather samples were generally collected during five storm events per year, and dry weather samples were generally collected during two dry events per year. Constituent types monitored included:

- Chlorinated Pesticides and PCBs
- Conventional Constituents (oil and grease, total phenols, cyanide, pH, and dissolved oxygen (DO))
- General Constituents (chloride, alkalinity, total suspended solids (TSS), turbidity, etc.)
- Herbicides
- Indicator Bacteria
- Metals
- Nutrients (ammonia, nitrate, phosphorus, etc.)
- Organophosphate Pesticides
- Semi-Volatile Organic Compounds

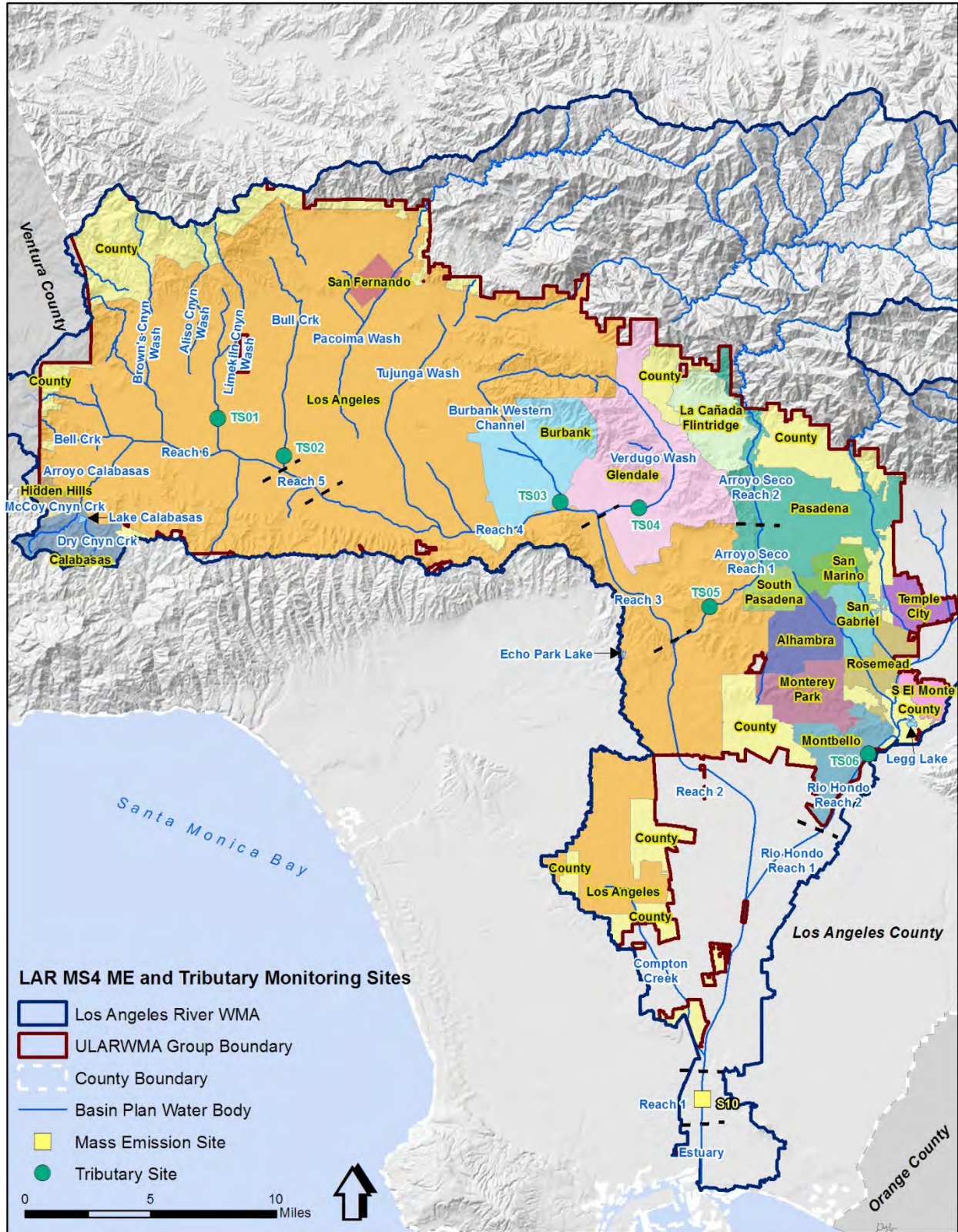

Figure 1. MS4 Mass Emission and Tributary Monitoring Locations in the Los Angeles River Watershed

1.2 Council for Watershed Health Monitoring Programs

The Los Angeles River Watershed Monitoring Program (LARWMP) is implemented by the Council for Watershed Health. The LARWMP includes programs under the Stormwater Monitoring Coalition (SMC). The LARWMP includes monitoring to address five core management questions related to priority beneficial uses:

- What is the condition of streams in the watershed?
- Are conditions at areas of unique interest getting better or worse?
- Are receiving waters near discharges meeting water quality objectives?
- Is it safe to swim?
- Are locally caught fish safe to eat?

The monitoring conducted under the LARWMP is summarized in **Table 1**. During the 2009-2013 five-year cycle, bioassessment monitoring was conducted under the LARWMP. The Council for Watershed Health will continue to conduct the LARWMP, which will include SMC Bioassessment Program monitoring for the next five-year cycle.

Table 1. Los Angeles River Watershed Monitoring Program Monitoring Summary

Question	Approach	Sites	Indicators	Frequency
1	Randomized design for streams in watershed	10 new per year	Triad: bioassessment, water chemistry, toxicity, CRAM	Annually, in spring
2	Fixed sites in freshwater and estuary	~6 high value	Riparian habitat (CRAM)	Annually, in summer
		4 trib confluence with mainstem 1 or 2 background sites	Bioassessment, water chemistry, toxicity, Riparian habitat (CRAM)	Annually, in spring
		1 estuary site	Conventional water quality Full suite water quality Sed. Chemistry, toxicity, infauna	Not determined Annually Annually
3	Assess NPDES RW Quality	Upstream and downstream of WRP discharges: LA/Glendale Burbank, Tillman WRP	Constituents with established WQ standards	Varies
4	Focus on high-use areas	6-10 in river	<i>Escherichia coli</i> (<i>E. coli</i>)	Weekly in swim season
		9 sentinel	<i>E. coli</i>	Weekly all year
		15 beach	Total coliforms, <i>E. coli</i> , Enterococcus	Annually in summer
5	Focus on Popular fishing sites Commonly caught species High-risk chemicals	3 lakes 2 river 1 estuary	Commonly caught fish at each location: Mercury, DDTs, PCBs, selenium	Annually in summer

1.3 Water Reclamation Plant Monitoring

There are four Water Reclamation Plants (WRPs) that discharge highly treated municipal wastewater effluent in the LAR watershed:

- City of Los Angeles Donald C. Tillman (DCT) WRP
- City of Los Angeles and Glendale Los Angeles-Glendale (LAG) WRP
- City of Burbank WRP
- Los Angeles County Sanitation District Whittier Narrows WRP

The four WRPs have similar monitoring requirements, which include receiving water, bioassessment, and watershed-wide monitoring. The watershed-wide sampling is conducted through the LARWMP as detailed above. The permitted flow and discharge locations for the WRPs are listed in **Table 2** and the discharge locations for the WRPs are displayed on **Figure 2**. An extensive list of constituents are monitored in the receiving waters upstream and downstream from the WRP discharges and include the following constituent classes:

- Conventionals
- Indicator bacteria
- Nutrients
- Metals
- PCBs
- DDTs
- Organochlorine and organophosphate pesticides
- Salts

Table 3 summarizes the WRPs' bioassessment, and receiving water monitoring locations. The constituents are monitored at various frequencies ranging from weekly to semiannually. The complete constituent list and monitoring frequency can be found in the DC Tillman, Burbank, LAG, and Whittier Narrows' WRP Monitoring and Reporting Programs.

Table 2. Locations for the WRPs Discharges in the LA River Watershed

WRP	Permitted Flow (MGD)	Discharge Locations
DCT	80	Los Angeles River Reach 4, Lake Balboa, Wildlife Lake
LAG	20	Los Angeles River Reach 3
Burbank	12.5	Burbank Western Channel
Whittier Narrows	15.0	Rio Hondo, San Gabriel River

Table 3. Current WRP Monitoring Locations and Monitoring Conducted in the Los Angeles River Watershed

WRP	Site	Location	Receiving Water	Bio-assessment
	R-7	LAR, 1800ft downstream of Discharge No. 008	X	X
	D	LAR and Hayvenhurst Channel confluence	X	X
	I	LAR upstream of Bull Creek	X	X
	J	Bull Creek at Lake Balboa weir	X	X
	K	Bull Creek, upstream of Lake Balboa intake	X	X
	W-E	LAR downstream of Haskell Flood Control Channel	X	X
DCT	The following sites associated with DCT are no longer monitored			
	R-2	LAR, 500ft downstream of Discharge No. 001	X	X
	R-8	LAR, upstream of confluence with Tujunga Wash	X	X
	R-9	LAR at Reseda Blvd, upstream of Discharges No. 001 and 008	X	X
	H	LAR and Bull Creek confluence	X	X
	W-C	LAR and Haskell Flood Control Channel confluence	X	X
	W-D	LAR upstream of Haskell Flood Control Channel	X	X
LAG	R-4	Upstream of discharge point No. 001 approximately 214 feet	X	
	R-7	Downstream of discharge point No. 001, at Los Feliz Boulevard	X	
Burbank	R-1	BWC at confluence with Lockheed Channel, ~300 ft above discharge No. 002	X	X
	R-2	BWC a Verdugo Wash, downstream of discharge No. 002	X	X
Whittier Narrows	R-D	Rio Hondo Flood Control Channel Downstream of Discharge Point 004	X	X
	RD-1	Rio Hondo Upstream of Discharge Point 004	X	X

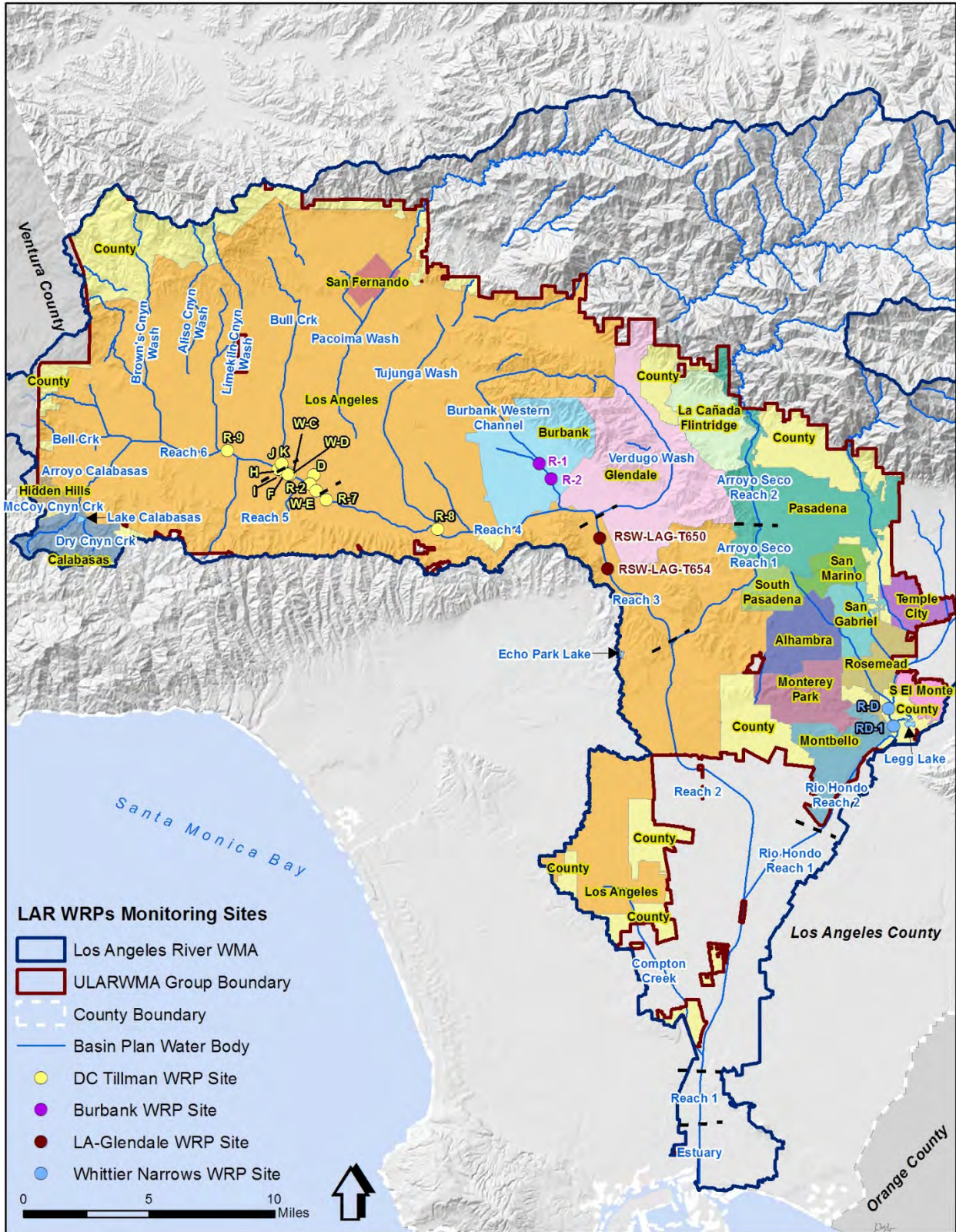

Figure 2. WRP Monitoring Locations in the Los Angeles River Watershed

1.4 Existing Total Maximum Daily Load Monitoring

The City of Los Angeles Watershed Protection Division (WPD) conducts monitoring outlined in the Los Angeles River Metals TMDL Coordinated Monitoring Plan (LAR Metals TMDL CMP), which was developed by the Los Angeles River Technical Committee to meet the requirements of the LAR Metals TMDL. The LAR Metals TMDL CMP includes a tiered approach. Tier I monitoring sites represent major portions of the total drainage area considering overlap. Monitoring is conducted at 13 Tier I monitoring locations throughout the LAR watershed.

Three Tier II monitoring stations are located upstream of Tier I stations at the downstream end of specific tributaries. These locations were selected by dividing the watershed into smaller tributary areas representing approximately four to six percent of the entire watershed. Tier III locations are intra-jurisdictional sites that were to be used if required. The Tier I monitoring locations are listed in **Table 4** and all monitoring locations are displayed on **Figure 3**. Monitoring consists of dry and wet weather sampling. Dry weather sampling is conducted monthly, unless pre-empted by collection of a wet weather sample. Wet weather sampling is conducted at five of the 13 Tier-1 stations (all on the mainstem) during storm events with not more than one storm event sampled per month with at least 72 hours between storm events. Constituents monitored each event include:

- Total and dissolved cadmium (Reach 1, wet weather only)
- Total and dissolved copper, lead, and zinc
- Total Selenium (Reach 6, dry weather only)
- Total hardness

A CMP developed by the City of Los Angeles, in cooperation with other responsible parties, to meet the requirements of the LAR Bacteria TMDL was submitted in 2013. However, this CMP was submitted with an acknowledgement that a CIMP would be developed and utilized as the basis of Bacteria TMDL monitoring after CIMP approval.

In March 2005, the County of Los Angeles and the cities of Los Angeles and Calabasas submitted on behalf of the LA River MS4 the *Monitoring Work Plan to Assess Nutrients Loading from the Municipal Separate Storm Sewer System in Los Angeles River Watershed*. In October 2005, the County submitted a report titled *Summary Report Los Angeles River Nutrients Dry Weather Sampling Program*. The report presented the results of sampling conducted at 10 locations strategically selected in the Watershed to avoid contribution from the three major WRPs and focus assessment on storm drain contribution at a variety of locations. The 10 sites, which included major tributary sites and key storm drains, were sampled five times between August and September 2005 to provide a comprehensive snapshot of storm drain influence throughout the entire watershed for the following constituents:

- Parameters: Dissolved Oxygen, Temperature, Conductivity, and pH
- Constituents: Ammonia, Nitrate + Nitrite, Nitrate-Nitrogen, and Nitrite-Nitrogen

The conclusions of the study found that the MS4s do not have a significant influence on nutrient loadings. The aforementioned constituents have been continued to be analyzed by the County at

the Mass Emission Station as well as by the cities of Los Angeles and Burbank as part of WRP monitoring.

To meet the requirements of the Legg Lake Trash TMDL, the County of Los Angeles and Los Angeles County Flood Control District (LACFCD) as well as non-ULARWMAG agencies (cities of El Monte and South El Monte and as the California Department of Transportation (Caltrans)) submitted a Trash Monitoring and Reporting Program (TMRP) on September 5, 2008, which was approved by the Los Angeles Regional Water Quality Control Board (Regional Board) on March 25, 2009. The TMRP presents the Minimum Frequency of Collection and Assessment (MFAC) /Best Management Practice (BMP) Program to comply with the TMDL. The MFAC/BMP Program was initiated on September 25, 2009 and has been conducted annually since. The County of Los Angeles Department of Parks and Recreation (DPR) Development Division completes daily trash percentage evaluation forms, weekly photographic evaluation surveys, and weekly photographic evidence for the MFAC/BMP Program. As a result of the MFAC/BMP Program, the numeric target of zero trash or no trash immediately following each assessment and collection event, as set forth in the TMDL, has been met at Legg Lake.

Table 4. Los Angeles River Metals TMDL CMP Locations

Site Name	Water Body	Description
LAR1-1	LA River Reach 6	Located at White Oak Avenue
LAR1-2	LA River Reach 5	Located at Sepulveda Boulevard
LAR1-3	Tujunga Wash	Located at Moorpark Street
LAR1-4	LA River Reach 4	Located at Tujunga Avenue
LAR1-5	Burbank Western Channel	Located at Riverside Drive
LAR1-6	LA River Reach 3	Located at Zoo Drive
LAR1-7	LA River Reach 3	Located at Figueroa Street
LAR1-8	LA River Reach 2	Located at Washington Boulevard
LAR1-9	LA River Reach 2	Located upstream of Rio Hondo between the 710 and Imperial Highway
LAR1-10	Rio Hondo	Located at Garfield Avenue
LAR1-11	LA River Reach 2	Upstream of Compton Creek at Del Amo Blvd
LAR1-12	Compton Creek	Upstream of Los Angeles River
LAR1-13	LA River Reach 1	Between Wardlow Road and Willow Street at LA County gauging station F319-R

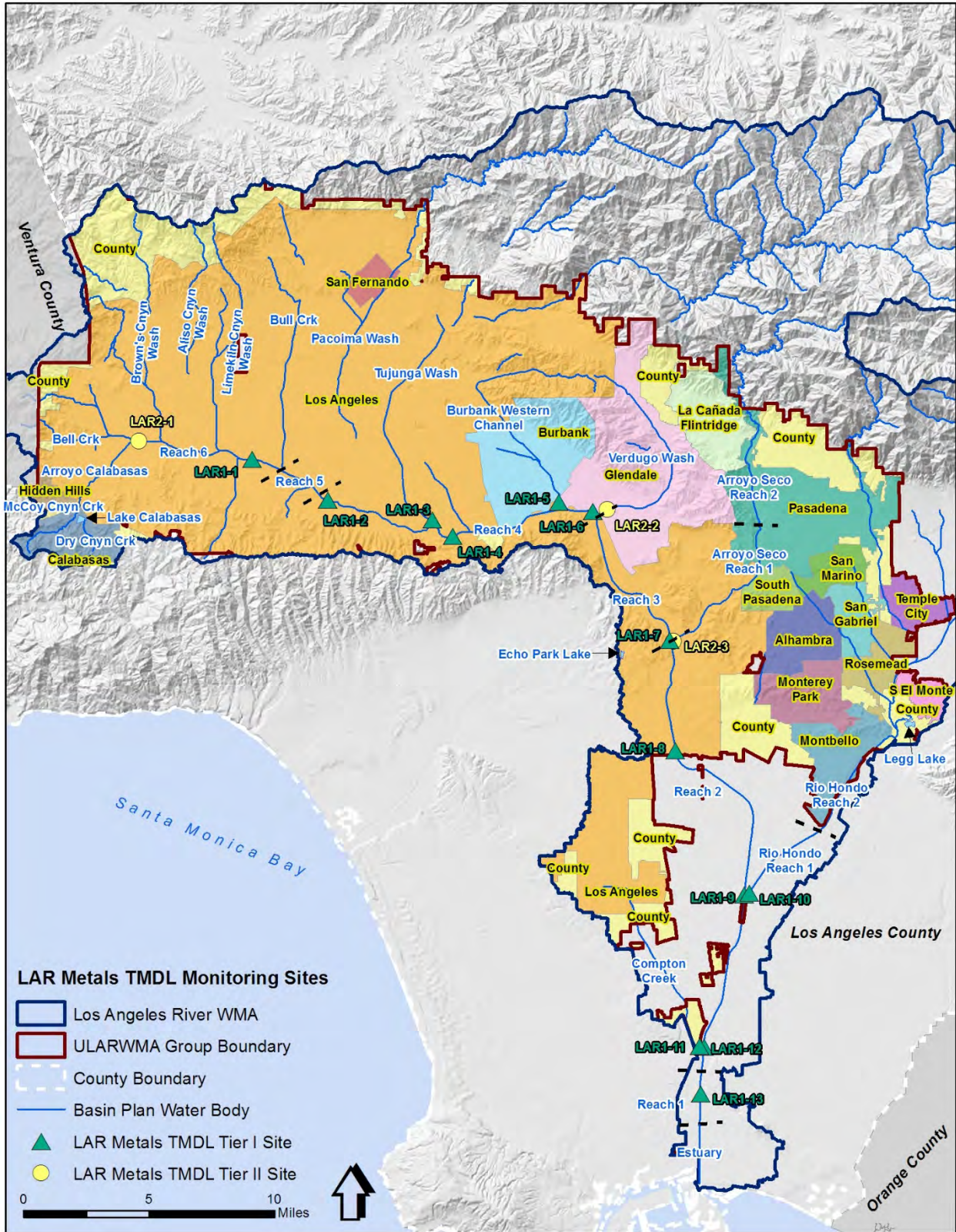

Figure 3. Los Angeles River Metals TMDL CMP Locations

2 TMDL Monitoring Requirements

One primary objective of the monitoring that will be conducted under the CIMP is fulfilling monitoring requirements established in TMDLs. The TMDLs addressing water body-pollutant combinations within or downstream of the EWMP area are presented in **Table 5**. Part XIX.B of the MRP, the TMDL Basin Plan Amendments (BPAs), and United States Environmental Protection Agency (USEPA)-established TMDL documents include TMDL monitoring requirements and recommendations, which are summarized in the following subsections. Appendix O of the Los Angeles County National Pollutant Discharge Elimination System (NPDES) MS4 Permit No. R4-2012-0175 (Permit) lists the TMDLs directly applicable in the EWMP area. The CIMP addresses the requirements summarized below.

Table 5. TMDLs Applicable to the Upper Los Angeles River Watershed EWMP

TMDL	Regional Board Resolution Number(s)	Effective Date and/or EPA Approval Date
LA River Nitrogen Compounds and Related Effects (LAR Nitrogen TMDL)	2003-009	03/23/2004
	2012-010	08/07/2014
Legg Lake Trash TMDL	2007-010	03/06/2008
Los Angeles River Trash TMDL	2007-012	09/23/2008
Los Angeles River and Tributaries Metals TMDL (LAR Metals TMDL)	2007-014	10/29/2008
	2010-003	11/03/2011
	2015-XXX	Not Yet Effective
Los Angeles River Bacteria TMDL (LAR Bacteria TMDL)	2010-007	03/23/2012
Dominguez Channel and Greater Los Angeles and Long Beach Harbor Waters Toxic Pollutants TMDL (Harbors Toxics TMDL)	2011-008	03/23/2012
Los Angeles Area Lakes TMDLs for Lake Calabasas, Echo Park Lake, and Legg Lake (Lakes TMDLs)	NA (USEPA TMDL)	03/26/2012

2.1 LAR Nitrogen TMDL

The LA River Nitrogen TMDL BPA required MS4 Permittees to submit a Work Plan to estimate nitrogen loadings from the storm drain system (Nitrogen Loadings Work Plan) and also required major NPDES Permittees (MS4s and WRPs) to submit a Work Plan to evaluate the effectiveness of nitrogen reductions on removing impairments from algae, odors, scums, and pH (Algae Work Plan). Both were required to be submitted by March 23, 2005. The TMDL CMP is being implemented as previously described in **Section 1.4** of this Attachment.

2.2 Legg Lake Trash TMDL

The Legg Lake Trash TMDL assigned wasteload allocations (WLAs) to the County of Los Angeles and LACFCD as well as load allocations to the County of Los Angeles. Monitoring is required when utilizing a MFAC Program to meet the WLA and LA requirements. The minimum frequency for collection is: (1) Whittier Narrows Recreation Park Area – five days per week on the shoreline and in the Park; and (2) Legg Lake – two days per week on waters of Legg Lake. Monitoring is being implemented as previously described in **Section 1.4** of this Attachment.

2.3 LAR Trash TMDL

The LAR Trash TMDL BPA does not require receiving water monitoring and Permittees are not required to conduct any type of monitoring if complying with WLAs through the installation of full capture systems. Permittees utilizing partial capture treatment systems and institutional controls must use a mass balance approach to estimate trash discharged. This is done through a calculated daily trash generation rate (DGR). The DGR is the average amount of trash accumulated in a specific land area over a 24-hour period. The DGR is used to estimate the amount of trash discharged after a storm event. The sum of all storm event discharges equals the calculated annual trash discharge for a Permittee. As such, Permittees utilizing partial capture treatment systems and institutional controls must directly measure the amount of trash deposited in the drainage area during any 30-day period from June 22nd to September 22nd each year (Provided no special events are scheduled that may affect the representative nature of this period.). Annual recalculation acts as a measure of the effectiveness of source reduction measures. The recommended method for measuring trash during this time period is to close the catch basins in a manner that prevents trash from being swept into the catch basins, and then to collect trash on the ground via street sweeping, manual pickup, or other comparable means. The DGR and storm event discharge are calculated using the following equations:

$$\text{DGR} = \text{Amount of trash collected during a 30-day period} / 30 \text{ days}$$

$$\text{Storm Event Discharge} = [\text{days since last street sweeping} * \text{DGR}] - \text{Amount of trash from catch basins}$$

2.4 LAR Metals TMDL

The LAR Metals TMDL requires ambient and TMDL effectiveness monitoring and specifies that total and dissolved metals and hardness are to be monitored monthly until the TMDL is re-considered at year five. The TMDL does not specify the requirements after the re-consideration. The TMDL CMP is being implemented as previously described in **Section 1.4** of this Attachment.

2.5 LAR Bacteria TMDL

Ambient monitoring, monitoring to assess attainment with WLAs, monitoring to support Load Reduction Strategies (LRS) or alternative compliance strategies, and monitoring to support wet-weather implementation plans are requirements for the Permittees listed in the LAR Bacteria TMDL. A CMP was required for submittal by March 23, 2013 to detail how the Permittees will conduct monitoring including the number and location of sites (at least one per water body covered by the Bacteria TMDL), measurements (e.g., *E. coli*), sample collection methods, and monitoring frequencies. The City of Los Angeles submitted a CMP on March 23, 2013, which

was developed in cooperation with other responsible parties. The CMP acknowledged that a CIMP would be developed and utilized as the basis of LAR Bacteria TMDL monitoring. Therefore, the MRP has not been approved by the Regional Board and monitoring has not commenced at this time. The requirements of the various types of monitoring required by the LAR Bacteria TMDL are summarized in **Table 6**. Note that the LA River Bacteria TMDL established five segments along the mainstem LA River (defined by cross streets/bridges) from its headwaters to near its mouth (see **Table 6**):

- **Segment E:** Reach 6 – LA River headwaters to Balboa Boulevard
- **Segment D:** Reach 5 to middle Reach 4 – Balboa Boulevard to Tujunga Avenue
- **Segment C:** lower Reach 4 and Reach 3 – Tujunga Avenue to Figueroa Street
- **Segment B:** upper and middle Reach 2 – Figueroa Street to Rosecrans Avenue
- **Segment A:** lower Reach 2 and Reach 1 – Rosecrans Avenue to Willow Street

Table 6. Summary of LAR Bacteria TMDL Monitoring Requirements

Monitoring Type	Requirements
Receiving Water Monitoring	Monitoring at one or more Permittee-specified sites per water body covered by the TMDL at a Permittee-specified frequency.
Compliance Monitoring	<p style="text-align: center;">Interim WLA:</p> Monitor each water body covered by the TMDL at least monthly until the end of the execution part of its first implementation phase. <p style="text-align: center;">In-stream targets:</p> Monitor each water body covered by the TMDL at least weekly after the first implementation phase.
Load Reduction Strategy (LRS)	<p style="text-align: center;">Pre-LRS Monitoring:</p> Conduct six “snapshot” monitoring events of E. coli and flow at all outfalls discharging to a water body. <p style="text-align: center;">Post-LRS Monitoring:</p> Conduct three “snapshot” monitoring events of E. coli and flow at all outfalls discharging to a water body
LRS Equivalent Condition Compliance ⁽¹⁾	Conduct six “snapshot” monitoring events of E. coli and flow at all outfalls discharging to a water body.
Wet-Weather Implementation Plans	Permittees must propose monitoring to support their Wet-Weather Implementation Plans.

1. For Permittees who choose to do a non-LRS mode of compliance.

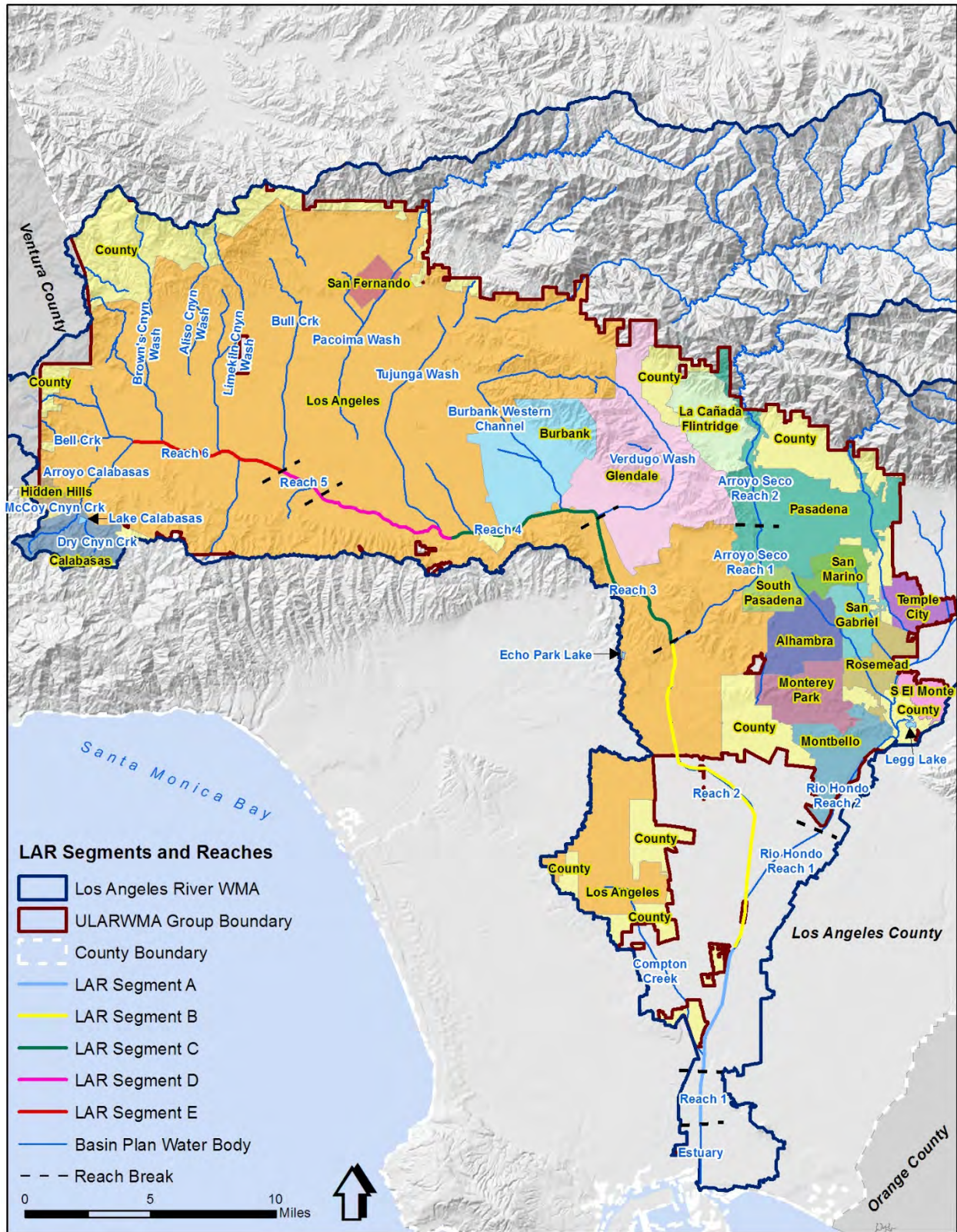

Figure 4. LAR River Watershed and Segments and Associated Tributaries

2.6 Harbors Toxics TMDL

While the Harbors Toxics TMDL was developed to address impairments in (among other water bodies) San Pedro Bay, it does apply to the jurisdictions in the ULARWMA Group because the LAR discharges to San Pedro Bay. The Harbors Toxics TMDL BPA monitoring requirements were incorporated into the Permit MRP (Part XIX.C). A summary of the monitoring requirements identified in the TMDL BPA is presented in **Table 7**. Note that rather than submitting a separate CMP or Quality Assurance Project Plan (QAPP) for the TMDL, the CIMP will address this TMDL's monitoring requirements. Note that as the LAR Estuary is not located within the ULARWMA, this CIMP does not address the related monitoring requirements.

Table 7. Summary of Harbors Toxics TMDL Monitoring Requirements

Locations	Medium	Constituents	Condition	Frequency
Upstream Receiving Water	Water and suspended solids	Metals ⁽¹⁾ , DDT, PCBs, PAHs, flow, general chemistry ⁽²⁾	Dry weather	Annually
			Wet weather	Twice per year ⁽³⁾
LAR Estuary	Sediment	General sediment quality constituents and the full chemical suite as specified in SQO Part 1	Not applicable	Every two years

1. Copper, lead, and zinc.
2. Temperature, DO, pH, and electrical conductivity.
3. Including the first large storm event of the season.

As recognized by the footnote in Attachment K-4 of the Permit, certain parties in the ULARWMA have entered into an Amended Consent Decree with the United States and the State of California, including the Regional Board, pursuant to which the Regional Board has released these parties from responsibility for Toxic pollutants in the Dominguez Channel and the Greater Los Angeles and Long Beach Harbors. Accordingly, no inference should be drawn from the submission of this CIMP or from any action or implementation taken pursuant to it that these parties are obligated to implement the DC Toxics TMDL, including this CIMP or any of the DC Toxics TMDL's other obligations or plans, or that these parties have waived any rights under the Amended Consent Decree.

2.7 Lakes TMDLs

Three lakes within the EWMP area are included in the USEPA Lakes TMDLs:

- Echo Park Lake Trash, Nutrients, PCBs, and Organochlorine Pesticides
- Lake Calabazas Nutrients
- Legg Lake Nutrients

The monitoring recommendations contained in the Lakes TMDLs were included in the MRP (Part XIX. D) as the requirements listed in **Table 8**.

Table 8. Summary of Lakes TMDL Monitoring Requirements

TMDL	Constituent(s)	Monitoring Frequency
Echo Park Lake Nutrient TMDL	<p align="center">In-lake Compliance Monitoring</p> <p>TMDL constituents: Ammonia, TKN or organic nitrogen, nitrate+ nitrite, orthophosphate, total phosphorus (total P), TSS, TDS, and chlorophyll a.</p> <p>General parameters throughout water column: Temperature, DO, pH, electrical conductivity (EC), and Secchi depth</p>	At a minimum, twice during summer months and once during winter.
	<p align="center">Stormwater Monitoring</p> <p>Discharge Point: Flow, ammonia, TKN or organic nitrogen, nitrate+nitrite, orthophosphate, total P, TSS, and TDS.</p>	Twice per year
Echo Park Lake PCBs and Organochlorine Pesticides TMDLs	<p align="center">In-lake Compliance Monitoring</p> <p>Water Quality TMDL constituents: TSS, total PCBs, total chlordane, total DDTs, and dieldrin</p> <p>Sediment Quality TMDL constituents: Total organic carbon (TOC), total PCBs, total chlordane, and dieldrin</p> <p>General parameters throughout water column: Temperature, DO, pH, EC, Secchi depth</p>	Annually
	<p align="center">Fish Tissue Monitoring</p> <p>OC Pesticides and PCBs must meet fish tissue targets in a composite sample of skin-off fillets from at least five largemouth bass > 350mm in length</p>	At least every three years
	<p align="center">Stormwater Monitoring</p> <p>Discharge Point: Collect sufficient volume of suspended solids to analyze TOC, TSS, total PCBs, total chlordane, and dieldrin. Measurements of flow, temperature, DO, pH, and EC</p>	Once per year during a wet weather event
	<p>Monitor trash deposited in the vicinity of Echo Park Lake and in the waterbody to comply with the TMDL target and gage implementation efforts effectiveness.</p>	Quarterly
Legg Lake Nutrient TMDL	<p align="center">In-lake Compliance Monitoring</p> <p>TMDL constituents: Ammonia, TKN or organic nitrogen, nitrate+ nitrite, orthophosphate, total P, TSS, TDS, and chlorophyll a.</p> <p>General parameters throughout water column: Temperature, DO, pH, EC, and Secchi depth</p>	At a minimum, twice during summer months and once during winter.
	<p align="center">Stormwater Monitoring</p> <p>Discharge Point: Flow, ammonia, TKN or organic nitrogen, nitrate+nitrite, orthophosphate, total P, TSS, and TDS.</p>	Twice per year
Lake Calabasas Nutrient TMDL	<p align="center">In-lake Compliance Monitoring</p> <p>TMDL constituents: Ammonia, TKN or organic nitrogen, nitrate + nitrite, orthophosphate, total P, TSS, TDS, and chlorophyll a.</p> <p>General parameters throughout water column: temperature, DO, pH, EC, flow, and Secchi depth</p>	At a minimum, twice during summer months and once during winter.
	<p align="center">Stormwater Monitoring</p> <p>Discharge Point: flow, ammonia, TKN or organic nitrogen, nitrate + nitrite, orthophosphate, total P, TSS, and TDS.</p>	Twice per year

2.8 Summary of TMDL Compliance Points

Table 9 presents interim and final compliance deadlines for the relevant TMDLs. The numeric water quality based effluent limitations (WQBELs) and receiving water limitations (RWLs) and the WLAs for the USEPA TMDLs listed in **Table 9** can be found in Attachment O of the Permit.

Table 9. Interim and Final TMDL Compliance Milestones Applicable to the Upper Los Angeles River Watershed

TMDL	Waterbodies	Constituents	Compliance Goal	Weather Condition	Compliance Dates and Compliance Milestones (Bolded numbers indicated milestone deadlines within the current Permit term) ⁽¹⁾								
					2012	2013	2014	2015	2016	2020	2024	2028	2032
LAR Nutrients	All Waterbodies	Ammonia-N, Nitrate-N, Nitrite-N, Nitrate-N+Nitrite-N	Meet WQBELs	All	Pre 2012								
					Final								
LAR Trash	All Waterbodies	Trash	% Reduction	All	9/30	9/30	9/30	9/30	9/30				
					70%	80%	90%	96.7%	100%				
Legg Lake Trash	Legg Lake	Trash	% Reduction	All	3/6	3/6	3/6	3/6	3/6				
					20%	40%	60%	80%	100%				
LAR Metals ⁽²⁾	Reach 1 through 6, CC, RH, AS, VW, BWC, TW, ACW, MC, DC, BeC and BuC	Copper, Lead, Zinc (only RH)	% of MS4 area Meets WQBELs	Dry	1/11					1/11	1/11		
					50%					75%	100%		
	All Waterbodies	Copper, Lead, Zinc, Cadmium	% of MS4 area Meets WQBELs	Wet	1/11					1/11	1/11		
					25%					50%	100%		
LA River Bacteria (Wet Weather)	All Waterbodies	<i>E. coli</i>	Meet WQBELs	Wet									3/23
													Final
Dominguez Channel and LA/LB Harbors Toxics	Estuary	Sediment: DDTs, PCBs, Copper, Lead, Zinc, PAHs	Meet WQBELs	All	3/23								
					Interim							Final	
USEPA Lakes TMDLs	Lake Calabastas	Total-P, Total-N	Meet WLAs	All									
	Legg Lake	Total-P, Total-N	Meet WLAs	All									
	Echo Park Lake	Total-P, Total-N, Trash Water and Sediment: PCBs, Chlordane, Dieldrin	Meet WLAs	All									

1. The Permit term is assumed to be five years from the Permit effective date (i.e., December 27, 2017).

3 Water Quality Priorities

The identification of water quality priorities is an important first step in the EWMP process. The water quality priorities provide the basis for prioritizing implementation and monitoring activities within the EWMP and CIMP. As part of the EWMP development, water quality was characterized and waterbody pollutant combinations (WBPCs) were placed into various categories. The information developed as part of the *Work Plan for the Enhanced Watershed Management Program for the Upper Los Angeles River Watershed* (EWMP Work Plan) was utilized to identify locations and constituents for monitoring. Additionally, the historical data utilized for characterization can be used in conjunction with data collected via the CIMP to support future modifications to the CIMP. The following briefly presents relevant key findings of the water quality analysis, the resulting WBPCs, and a description of how the WBPCs are addressed in this CIMP. For additional details on the analysis and results see the EWMP Work Plan.

3.1 Summary of Key Findings of Receiving Water Data Analysis

The following provides a summary of key findings from the receiving water data analysis that affect the monitoring approach contained in this CIMP. It is not intended to be a detailed discussion of all the results of the data analysis. Instead, the summary highlights outcomes of the data analysis that may affect the constituents addressed by the CIMP and/or the way the CIMP approaches addressing the constituent. The key findings are organized as follows:

1. Summary of key findings related to the LAR Nutrients TMDL.
2. Constituents not on the 2010 303(d) List, but appear to meet the listing requirements.
3. Constituents exceeding objectives, but do not meet the 303(d) listing requirements.
4. Identification of current 303(d) listed constituents not addressed by a TMDL that appear to meet the delisting requirements.

3.1.1 Key findings related to the LA River Nutrients TMDL

Over the past five years ammonia, nitrate and nitrite have rarely exceeded (<0.3%) LAR Nutrients TMDL targets. This is likely due to the fact that the primary sources of these constituents are the DCT, LAG, Burbank, and Whittier Narrows WRPs all upgraded their facilities to include nitrification/de-nitrification processes more than five years ago. The data analysis suggests that ammonia, nitrate and nitrite are not water quality issues in the Watershed. The following provides a generalized summary of the key findings from comparing the data collected over the past five years to the LAR Nutrients TMDL targets:

- Ammonia as N: Of the 2,015 samples collected only one exceeded (Tujunga Wash).
- Nitrate as N: Of the 2,015 samples collected zero samples exceeded.
- Nitrite as N: Of the 2,015 samples collected only one exceeded (Arroyo Seco).
- Nitrogen (NO₃-N+NO₂-N): Of the 2,015 samples collected zero samples exceeded.

3.1.2 Constituents not on the 2010 303(d) List, but appear to meet listing requirements

The data analysis identified a number of constituents exceeding relevant water quality objectives, at a frequency that appears to meet the 303(d) listing criteria. **Table 10** identifies the constituents by waterbody and presents the frequency of exceedances during wet and/or dry weather conditions over the past five and ten year periods.

Table 10. Summary of Key Findings – Constituents not Currently on the 2010 303(d) List, but Appear to Meet Listing Criteria

Waterbody	Constituent	Wet/ Dry	Date Range of Data		N	% Exceed	Past 5 Years		Source of Water Quality Objective
							N	% Exceed	
Aliso Canyon Wash	Bis(2-ethylhexyl)Phthalate	Dry	10/03	1/04	2	100%	NS	NS	CTR HH Organism
		Wet	10/03	2/04	4	75%	NS	NS	CTR HH Organism
Arroyo Seco	Bis(2-ethylhexyl)Phthalate	Wet	10/03	2/04	4	75%	NS	NS	CTR HH Organism
Bull Creek	Bis(2-ethylhexyl)Phthalate	Dry	10/03	1/04	2	100%	NS	NS	CTR HH Organism
		Wet	10/03	2/04	4	50%	NS	NS	CTR HH Organism
Burbank Western Channel	2,3,7,8-TCDD (Dioxin)	Dry	2/07	8/13	64	44%	40	43%	CTR HH Organism
	Bis(2-ethylhexyl)Phthalate	Dry	10/03	8/13	137	26%	45	18%	CTR HH Organism
		Wet	10/03	2/04	4	75%	NS	NS	CTR HH Organism
	Chlorine (Total)	Wet	2/04	2/12	42	12%	7	0%	BP Aquatic Life Objective
	Chlorodibromomethane	Dry	2/04	10/13	231	12%	123	1%	CTR HH Organism
Echo Park Lake	Mercury Total	Wet	2/04	2/05	6	50%	NS	NS	CTR HH Organism
Rio Hondo Reach 2	Bis(2-ethylhexyl)Phthalate	Dry	10/03	1/04	2	100%	NS	NS	CTR HH Organism
		Wet	10/03	2/04	4	75%	NS	NS	CTR HH Organism
Rio Hondo Reach 2	Copper Total	Dry	1/04	12/12	105	24%	46	7%	CTR Chronic
	Dissolved Oxygen	Dry	1/04	12/12	210	36%	46	41%	Basin Plan Minimum
	pH	Dry	1/04	12/12	210	21%	46	11%	Basin Plan Maximum
Tujunga Wash	Chloride	Dry	6/09	6/11	3	100%	3	100%	BP SSO
Verdugo Wash Reach 1	Bis(2-ethylhexyl)Phthalate	Dry	10/03	1/04	2	100%	NS	NS	CTR HH Organism
		Wet	10/03	2/04	4	75%	NS	NS	CTR HH Organism
LAR Reach 1	Bis(2-ethylhexyl)Phthalate	Dry	10/02	7/13	29	10%	17	6%	CTR HH Organism
	Mercury Total	Dry	6/01	7/13	81	14%	17	0%	CTR HH Organism
	pH	Dry	10/02	7/13	48	67%	16	75%	BP Maximum
LAR Reach 2	Mercury Total	Dry	4/01	6/10	108	19%	2	0%	CTR HH Organism
		Wet	1/01	3/05	9	22%	NS	NS	CTR HH Organism
	pH	Dry	3/06	2/08	40	75%	NS	NS	BP Maximum

Waterbody	Constituent	Wet/ Dry	Date Range of Data		N	% Exceed	Past 5 Years		Source of Water Quality Objective
							N	% Exceed	
LAR Reach 3, below LAG	2,3,7,8-TCDD (Dioxin)	Dry	8/07	9/13	14	14%	11	18%	CTR HH Organism
	Mercury Total	Dry	4/01	11/13	156	11%	23	0%	CTR HH Organism
LAR Reach 3, above LAG	Mercury Total	Dry	5/01	11/13	11	9%	23	0%	CTR HH Organism
LAR Reach 4	Mercury Total	Dry	4/01	11/13	231	14%	37	0%	CTR HH Organism
		Wet	1/01	3/05	10	20%	NS	NS	CTR HH Organism
LAR Reach 5	Chloride	Dry	5/07	11/13	81	28%	60	28%	BP Maximum
	Diazinon	Dry	5/12	9/13	18	11%	18	11%	USEPA Chronic
	Sulfate	Dry	5/07	11/13	81	36%	60	37%	BP SSO
	TDS	Dry	5/07	8/13	78	32%	57	32%	BP SSO
LAR Reach 6	Chloride	Dry	2/02	6/10	49	43%	1	100%	BP SSO
	Mercury Total	Dry	4/01	6/10	111	12%	2	0%	CTR HH Organism
	Sulfate	Dry	2/02	6/10	49	98%	1	100%	BP SSO
	TDS	Dry	2/02	11/08	28	100%	NS	NS	BP SSO
	Thallium Total	Dry	3/01	8/08	71	8%	NS	NS	CTR HH Organism

BP = Basin Plan

SSO = Site Specific Objective

CTR = California Toxics Rule

NS = Not Sampled within the past five years.

HH Organism = Human Health Organisms only criteria

3.1.3 Constituents exceeding objectives, but do not meet the listing requirements

The data analysis identified a number of constituents as exceeding relevant water quality objectives, but not at a frequency that meets the 303(d) listing criteria. **Table 11** identifies the constituents by waterbody and presents the frequency of exceedances during relevant conditions (e.g., wet and/or dry weather) over the past five and ten year periods.

Table 11. Summary of Key Findings – Constituents Exceeding Objectives, but do not Appear to Meet Listing Criteria

Waterbody	Constituent	Wet /Dry	Date Range of Data		N	% Exceed	Past 5 Years		Source of Water Quality Objective
							N	% Exceed	
Aliso Canyon Wash	Cyanide	Wet	10/03	2/04	4	25%	NS	NS	CTR Acute
	Diazinon	Wet	10/03	2/04	4	25%	NS	NS	USEPA Acute
	Sulfate	Dry	10/03	5/09	3	33%	1	100%	BP SSO
	TDS	Dry	10/03	5/09	3	33%	1	100%	BP SSO
Arroyo Seco	Bis(2-ethylhexyl)Phthalate	Dry	10/03	1/04	2	50%	NS	NS	CTR HH Organism
	Mercury Total	Wet	10/03	3/05	6	17%	NS	NS	CTR HH Organism
Bull Creek	Cyanide	Wet	10/03	2/04	4	25%	NS	NS	CTR Acute
Burbank Western Channel	Benzo(a)Pyrene	Dry	10/03	8/13	137	1%	45	2%	CTR HH Organism
	Benzo(b)Fluoranthene	Dry	2/04	8/13	135	4%	45	4%	CTR HH Organism
	beta-BHC	Dry	10/03	8/13	131	1%	39	0%	CTR HH Organism
	Chloride	Dry	10/03	8/13	239	3%	125	3%	BP SSO
	Chlorine (Total)	Dry	10/03	10/13	1299	5%	526	3%	BP Aquatic Life Objective
	Cyanide	Dry	10/03	10/13	206	7%	93	1%	CTR Chronic
	Heptachlor	Dry	10/03	8/13	131	1%	39	0%	CTR HH Organism
	Mercury Total	Dry	10/03	8/13	244	7%	99	1%	CTR HH Organism
	Mercury Total	Wet	10/03	3/05	7	14%	NS	NS	CTR HH Organism
	pH	Dry	10/03	10/13	805	1%	249	0%	BP Minimum
	pH	Wet	10/03	1/08	41	10%	NS	NS	BP Minimum
	TDS	Dry	10/03	8/13	170	1%	55	2%	BP SSO
	Caballero Creek	Thallium Total	Dry	10/03	8/13	61	2%	21	0%
Mercury Total		Dry	2/05	2/06	12	8%	NS	NS	CTR HH Organism
Nickel Total		Dry	2/05	8/08	41	2%	NS	NS	CTR Chronic
Compton Creek	Chloride	Dry	6/09	6/11	4	50%	4	50%	BP SSO
	Chlorpyrifos	Dry	6/09	6/11	4	25%	4	25%	USEPA Chronic
	Mercury Total	Dry	2/05	6/11	16	6%	4	0%	CTR HH Organism
	Mercury Total	Wet	1/05	3/05	2	50%	NS	NS	CTR HH Organism
Echo Park Lake	Mercury Total	Dry	5/03	11/10	87	3%	24	0%	CTR HH Organism

Waterbody	Constituent	Wet /Dry	Date Range of Data		N	% Exceed	Past 5 Years		Source of Water Quality Objective
							N	% Exceed	
Rio Hondo Reach 2	Cyanide	Dry	10/03	1/04	2	50%	NS	NS	CTR Chronic
	Diazinon	Wet	10/03	2/04	4	25%	NS	NS	USEPA Acute
	pH	Dry	10/03	1/04	2	50%	NS	NS	BP Minimum
	pH	Wet	10/03	2/04	4	25%	NS	NS	BP Minimum
Rio Hondo Reach 3	Benzo(a)Pyrene	Dry	2/04	8/12	43	2%	9	22%	CTR HH Organism
	Benzo(k)Fluoranthene	Dry	2/04	8/12	43	2%	9	22%	CTR HH Organism
	Chloride	Dry	1/04	12/12	111	1%	52	0%	Basin Plan SSO
	Chrysene	Dry	2/04	8/12	43	2%	9	22%	CTR HH Organism
	Diazinon	Dry	2/04	11/12	60	5%	17	12%	CTR Chronic
	Dibenzo(a,h)Anthracene	Dry	2/04	8/12	43	5%	9	78%	CTR HH Organism
	Indeno(1,2,3-cd)Pyrene	Dry	2/04	8/12	36	3%	8	75%	CTR HH Organism
	Mercury Total	Dry	2/04	12/12	74	3%	41	2%	CTR HH Organism
Tujunga Wash	Mercury Total	Dry	2/05	6/11	15	7%	3	0%	CTR HH Organism
	TDS	Dry	6/09	6/09	1	100%	1	100%	BP SSO
Verdugo Wash Reach 1	Mercury Total	Wet	10/03	3/05	6	17%	NS	NS	CTR HH Organism
LAR Reach 1	Bis(2-ethylhexyl)Phthalate	Wet	11/02	5/13	49	8%	23	4%	CTR HH Organism
	Diazinon	Wet	11/02	5/13	41	2%	16	0%	USEPA Acute
	Dissolved Oxygen	Wet	11/02	5/13	41	2%	17	0%	BP Minimum
	Mercury Total	Wet	11/02	5/13	52	4%	23	0%	CTR HH Organism
	pH	Wet	11/02	1/13	50	4%	23	0%	BP Maximum
	Thallium Total	Dry	3/01	7/13	91	3%	23	0%	CTR HH Organism
LAR Reach 2	pH	Wet	12/07	1/08	4	50%	NS	NS	BP Maximum
	Thallium Total	Dry	3/01	2/06	112	2%	NS	NS	CTR HH Organism
LAR Reach 3, above LAG	2,3,7,8-TCDD (Dioxin)	Dry	8/07	9/13	13	8%	9	0%	CTR HH Organism
	2,3,7,8-TCDD (Dioxin)	Wet	2/10	2/10	2	50%	2	50%	CTR HH Organism
	Bis(2-ethylhexyl)Phthalate	Dry	2/02	9/13	44	2%	14	0%	CTR HH Organism
	Cyanide	Dry	2/02	11/13	64	8%	22	0%	CTR Chronic
	Dibenzo(a,h)Anthracene	Dry	2/02	9/13	47	4%	15	0%	CTR HH Organism

Waterbody	Constituent	Wet /Dry	Date Range of Data		N	% Exceed	Past 5 Years		Source of Water Quality Objective
							N	% Exceed	
	Indeno(1,2,3-cd)Pyrene	Dry	2/02	9/13	22	5%	9	0%	CTR HH Organism
	Mercury Total	Dry	5/01	11/13	129	9%	23	0%	CTR HH Organism
	Mercury Total	Wet	1/01	2/10	7	14%	1	0%	CTR HH Organism
	Nickel Total	Dry	3/01	8/13	140	1%	19	0%	CTR Chronic
	pH	Dry	1/02	11/13	583	2%	232	5%	BP Minimum
	Sulfate	Dry	2/02	11/13	68	1%	21	0%	BP SSO
	Thallium Total	Dry	3/01	8/13	91	2%	18	0%	CTR HH Organism
LAR Reach 3, below LAG	2,3,7,8-TCDD (Dioxin)	Wet	2/10	2/10	2	50%	2	50%	CTR HH Organism
	Benzo(a)Anthracene	Dry	2/02	9/13	75	1%	16	0%	CTR HH Organism
	Bis(2-ethylhexyl)Phthalate	Dry	2/02	9/13	70	1%	15	0%	CTR HH Organism
	Chrysene	Dry	2/02	9/13	75	1%	16	0%	CTR HH Organism
	Cyanide	Dry	2/02	11/13	102	6%	23	0%	CTR Chronic
	Dibenzo(a,h)Anthracene	Dry	2/02	9/13	75	8%	16	0%	CTR HH Organism
	Dichlorobromomethane	Wet	2/10	2/10	1	100%	1	0%	CTR HH Organism
	Dissolved Oxygen	Dry	1/02	11/13	879	2%	235	0%	BP Minimum
	Indeno(1,2,3-cd)Pyrene	Dry	2/02	9/13	34	6%	9	0%	CTR HH Organism
	Mercury Total	Wet	1/01	2/10	8	13%	1	0%	CTR HH Organism
LAR Reach 4	Thallium Total	Dry	3/01	8/13	86	2%	18	0%	CTR HH Organism
	Chrysene	Dry	2/02	8/13	38	3%	10	0%	CTR HH Organism
	Cyanide	Dry	2/02	11/13	123	6%	37	3%	CTR Chronic
	Diazinon	Dry	6/11	9/13	7	14%	7	14%	CTR Chronic
	Dissolved Oxygen	Dry	1/02	11/13	901	1%	227	0%	BP Minimum
	Sulfate	Dry	2/02	11/13	111	9%	21	5%	BP SSO
	TDS	Dry	2/02	8/13	75	8%	19	0%	BP SSO
LAR Reach 5	Thallium Total	Dry	3/01	8/13	128	2%	10	0%	CTR HH Organism
	4,4-DDD	Dry	2/02	8/13	72	3%	30	3%	CTR HH Organism
	4,4-DDE	Dry	2/02	8/13	72	6%	30	7%	CTR HH Organism
	Bis(2-ethylhexyl)Phthalate	Dry	2/02	8/13	84	1%	30	0%	CTR HH Organism
	Cyanide	Dry	2/02	11/13	156	3%	102	1%	CTR Chronic

Waterbody	Constituent	Wet /Dry	Date Range of Data		N	% Exceed	Past 5 Years		Source of Water Quality Objective
							N	% Exceed	
	Dibenzo(a,h)Anthracene	Dry	2/02	8/13	75	1%	30	3%	CTR HH Organism
	Dissolved Oxygen	Dry	1/02	11/13	1684	8%	674	4%	BP Minimum
	Heptachlor	Dry	2/02	8/13	72	3%	30	0%	CTR HH Organism
	Indeno(1,2,3-cd)Pyrene	Dry	2/02	8/13	75	1%	30	3%	CTR HH Organism
	Mercury Total	Dry	2/02	11/13	156	4%	102	0%	CTR HH Organism
	Nickel Total	Dry	2/02	8/13	72	1%	30	3%	CTR Chronic
LAR Reach 6	2,3,7,8-TCDD (Dioxin)	Dry	8/07	8/08	4	25%	NS	NS	CTR HH Organism
	Chlorine (Total)	Dry	1/02	1/09	321	1%	3	0%	BP Aquatic Life Objective
	Chrysene	Dry	2/02	8/08	15	7%	NS	NS	CTR HH Organism
	Cyanide	Dry	2/02	1/09	44	2%	1	0%	CTR Chronic
	Mercury Total	Wet	1/01	3/05	7	14%	NS	NS	CTR HH Organism

BP = Basin Plan

SSO = Site Specific Objective

CTR = California Toxics Rule

NS = Not Sampled within the past five years.

HH Organism = Human Health Organisms only criteria

3.1.4 Identification of current 303(d) listed constituents not addressed by a TMDL that meet the delisting requirements

A number of 303(d) listings not addressed by an existing TMDL were identified as potentially meeting delisting requirements as shown in **Table 12**.

Table 12. 2010 303(d) Listed Water Body Pollutant Combinations in the Los Angeles River Watershed not Addressed by a TMDL that Appears to Meet Delisting Requirements

Constituent	Los Angeles River			Burbank Western Channel
	1	2	5	
Diazinon	Wet			
Cyanide				Wet/Dry
Selenium				Wet/Dry
Oil		Dry	Dry	

Diazinon – LA River Reach 1: Diazinon in LA River Reach 1 was listed based on two of 22 samples exceeding criteria developed by the California Department of Fish and Game (DFG) at the County of Los Angeles mass emission station between October 2000 and April 2003. A review of the past 10 years of data, which includes the data identified in the 303(d) listing fact sheet, indicates that only one of 41 samples during wet weather and zero of 36 dry weather samples exceed USEPA’s recommended criteria for diazinon. Although neither criteria have been formally adopted by California, USEPA’s criteria is utilized rather than the DFG criteria as it was completed in 2005 (five years after DFG’s) and it addresses a transcription error in the DFG criteria. The data analysis suggests diazinon is not a water quality issues in LAR Reach 1.

Cyanide – Burbank Western Channel: Cyanide in Burbank Western Channel was listed based on two of six samples exceeding CTR chronic criterion at a LA County tributary station monitored between October 2003 and February 2004. A review of the past 10 years of data, which includes the data identified in the 2010 303(d) listing fact sheet, indicates that:

- One of the two exceedances noted in the 2010 303(d) listing fact sheet occurred during wet weather and should have been compared to the CTR acute criterion.
- Of the four wet weather samples collected all were below the CTR acute criterion.
- Of the 206 dry weather samples collected over the past 10 years, 15 exceeded the CTR chronic criteria.
- Of the 93 dry weather samples collected in the past five years, only one of 93 (1%), exceeded.
- The 303(d) listing guidance indicates that with a sample size as large as 206 a delisting can occur if there are 17 or fewer exceedances. The data analysis suggests that cyanide in the Burbank Western Channel is not a water quality issues based on the past 10 years of available data and, particularly given the past five years of data.

Selenium – Burbank Western Channel: Selenium in Burbank Western Channel was listed based on 12 of 48 samples exceeding CTR chronic criterion at stations sampled by the Burbank

WRP during dry weather. A review of the past 10 years of data, which includes the data identified in the 2010 303(d) listing fact sheet, indicates that:

- Of the 235 dry weather samples collected over the past 10 years, 15 exceeded the CTR chronic criteria.
- Of the 99 dry weather samples collected in the past five years, zero exceeded.

The 303(d) listing guidance indicates that with a sample size as large as 235 a delisting can occur if there are 19 or fewer exceedances. The data analysis suggests that selenium in the Burbank Western Channel is not a water quality issues based on the past 10 years of available data and, particularly given the past five years of data.

Oil – LA River Reaches 2 and 5: The 2010 303(d) listing fact sheet does not provide a synopsis of the data used to list oil in LA River Reach 2 or 5. As stated in the fact sheet, “303(d) listing decisions made prior to 2006 were not held in an assessment database. The Regional Boards will update this decision when new data and information become available and are assessed.” Repeated efforts have been made to obtain the historical information utilized to develop the original listing; however, the Regional Board has not provided the information for inclusion in the analysis. Therefore, the following is based information gathered by the City of Los Angeles, Bureau of Sanitation, Watershed Protection Division (WPD). Three relevant studies/correspondences were reviewed:

- Pollution Report (2002), USEPA Region IX
- Correspondence (2002) from Michael P. Brown, Manager, Geotechnical Engineering Division, Bureau of Engineering, City of Los Angeles
- Correspondence (2002) from Steven Poole, Claims Manager, United States Coast Guard, National Pollution Funds Center

The source of oil seeping into the River was found to be naturally-occurring crude oil. This conclusion is supported by the results of investigations completed by various agencies, which are summarized as follows. An investigation was conducted following seeps of petroleum hydrocarbons into the LA River in June 2001. Based on lab results and borings, it was concluded that the source of the LA River channel oil seeps is naturally-occurring crude oil from Puente formation sands. Oil was visible in Puente formation seams, partings and fractures, as well as sand lenses, and appeared to have migrated upward into sandy alluvial soils. Gasses encountered included hydrogen sulfide, commonly sources from crude oil reservoirs. The hydrocarbon seeps appeared to be concentrated where the Puente formation contacts with younger, less permeable units or layers.

The USEPA On-Scene Coordinator (OSC) conducted subsurface investigations of the oil seeps in the LA River during August and September 2001. Based on the investigation, the OSC found that the oil did not discharge as a result of a spill, leak, or discharge from any facility. The oil has been discharging to the river since at least 1943 and there is no practical means of preventing this oil seep from discharging to the LA River.

On April 19, 2002, an email was sent to Steven Pederson of WPD by Steven Poole of the US Coast Guard/National Pollution Funds Center (USCG/NPFC). Mr. Poole stated that City of Los Angeles cannot submit to USCG/NPFC a claim for reimbursement for cost incurred by the City associated with May 2001 oil clean-up efforts in the LA River because Title 1 of the Oil Pollution Act does not allow for reimbursement for naturally-occurring oil (natural seepage).

In summary, the reports and correspondence indicate that multiple agencies believe that the oil found in the listed reaches of the LA River is associated with naturally occurring seepage suggesting that a 303(d) listing is not warranted, or at a minimum, not addressable through the MS4 Permit.

3.2 Waterbody Pollutant Combinations

Water quality priorities for the EWMP area are based on TMDLs, the 2010 303(d) list, and monitoring data. Based on available information and data analysis, Waterbody Pollutant Combinations (WBPCs) were classified in one of the three Permit defined categories. The process for categorizing water quality priorities is summarized in the EWMP Work Plan. For brevity, only the resulting Categories are presented. **Table 13** presents the ULARWVG WBPCs in Categories 1, 2 and 3 for the mainstem LA River. **Table 14** and **Table 15** present the WBPCs for the LA River tributaries. **Table 16** presents the WBPCs categories for Lake Calabasas, Legg Lake, and Echo Park Lake. The three Permit categories are defined as:

- Category 1: WBPCs for which TMDL WQBELs and/or RWLs are established in Part VI.E and Attachments L and O of the MS4 Permit.
- Category 2: WBPCs for which data indicate water quality impairment in the receiving water according to the Water Quality Control Policy for Developing California's Clean Water Act Section 303(d) List (Listing Policy), regardless of whether the pollutant is currently on the 303(d) List and for which the MS4 discharges may be causing or contributing.
- Category 3: WBPCs for which there are insufficient data to indicate impairment in the receiving water according to the Listing Policy, but which exceed applicable receiving water limitations contained in the MS4 Permit and for which MS4 discharges may be causing or contributing to the exceedance.

To further support development of the Work Plan and EWMP, the three Permit categories were further subdivided into subcategories and each WBPC was assigned to an appropriate subcategory. Additionally, pollutants were identified as belonging to a specific "class". As stated in the Permit (pg. 49, footnote 21), pollutants are considered in a similar class if they have similar fate and transport mechanisms, can be addressed via the same types of control measures, and within the same timeline already contemplated as part of the EWMP for the TMDL. The "classes" are preliminary in nature and may be refined as part of EWMP development. The following classes were identified:

- Metals
- Trash
- Bacteria
- Sediment

- Historical Organics – inclusive of historical pesticides.
- Current Organics – inclusive of current use pesticides and other organics such as PAHs.
- To be determined – used for conditions (pH and dissolved oxygen) that are not pollutants, per se, or constituents where the linkage to another type of constituent will be further investigated during EWMP development.

Constituents may change subcategories as the monitoring progresses, source investigations occur, and BMP implementation begins. Constituents for which exceedances decrease over time will be removed from the priority list and moved to the monitoring priority categories; or, dropped from the priority list. If the frequency of constituent exceedances increases to a consistent level, for a constituent that is currently not a priority, then the constituent would be reevaluated using the prioritization procedure, likely increasing the priority of the constituent.

Constituents that were identified as a water quality priority are included in this CIMP and monitored as described below.

Category 1 WBPCs: All WBPCs required to be monitored by a TMDL through either a Basin Plan Amendment approved by the Regional Board or through monitoring requirements specified in the MRP will be monitored as part of this CIMP, except as described below:

- The LAR Bacteria TMDL schedule required a wet weather implementation plan be submitted 10 years after the effective date of the TMDL (April 2022), with final compliance due 25 years after the effective date (April 2037). Given the timeframe for implementation and the significant amount of implementation that will occur prior to the first TMDL milestone (10 years), collection of bacteria data during wet weather throughout the ULAR EWMP area at this time will not provide meaningful information upon which to make management decisions. As such, wet weather monitoring related to the LAR Bacteria TMDL will be conducted at the downstream boundary of the ULAR EWMP area to assess trends over time, but in no other locations at this time. The need for such information will be evaluated during EWMP and CIMP implementation and will be added in the future.
- As described in the key findings related to the LAR Nutrients TMDL (**Section 3.1.1** of this Attachment), over 8,000 samples have been collected in the last five years for nitrogen related constituents (ammonia, nitrate, and nitrite) with only two exceedances. Additionally, as described in **Section 1.3** of this Attachment, data is currently collected by the four water reclamation plants (WRPs) in the EWMP area and the ULARWMAG can utilize those data to evaluate if additional monitoring is warranted at other locations in the Watershed in the future. To assess trends in pollutant concentrations over time, monitoring for relevant constituents will be conducted at the downstream boundary of the ULAR EWMP area to assess trends over time, but in no other locations at this time.

Category 2 WBPCs: All WBPCs that are included on the current 303(d) list will be monitored. All WBPCs for which data indicate water quality impairment in the receiving water according to the Listing Policy will be monitored as part of this CIMP, except as described below:

- Chlorodibromomethane and chlorine in Burbank Western Channel (BWC) will not be monitored as part of this CIMP as these constituents are associated with wastewater treatment. As such, MS4 discharges are not suspected to be causing or contributing to this impairment.
- Thallium in LAR Reach 6 will not be monitored as part of this CIMP given the low exceedance frequency in the watershed of 18 of 928 samples in the past 10 years and 0 of 108 samples in the past five years. Note that data collected by the WRPs can be evaluated to determine if monitoring by the ULARWMAG is warranted in the future.

Category 3 WBPCs: All WBPCs for which there are insufficient data to indicate impairment in the receiving water according to the Listing Policy, but which have exceeded applicable receiving water limitations in the past five years and for which MS4 discharges may be causing or contributing to the exceedance will be monitored as part of this CIMP, except as described below:

- 2,3,7,8-TCDD (Dioxin) in LAR Reach 3 and BWC will not be monitored as part of this CIMP given that this constituent will be monitored by the LAGWRP in Reach 3 and the BWRP in the BWC. The data collected by the LAGWRP and BWRP can be evaluated to determine if monitoring by the ULARWMAG is warranted in the future.
- Cyanide in LAR Reach 4, LAR Reach 5, and BWC will not be monitored as part of this CIMP given 1) the low exceedance frequency in LAR Reach 4 (7 of 123 samples and 1 of 37 in the past 10 and five years, respectively), LAR Reach 5 (4 of 156 and 1 of 102 in the past 10 and five years, respectively), and BWC (15 of 210 and 1 of 93 in the past 10 and five years, respectively) and 2) that it is potentially a sample collection/preservation issue. Note that cyanide data will be collected as part of this CIMP at the downstream boundary of the ULAR EWMP area and by the DCTWRP, LAGWRP, and BWRP. These data can be evaluated to determine if additional monitoring by the ULARWMAG is warranted in the future.
- Dibenzo(a,h)Anthracene will not be monitored as part of this CIMP in LAR Reach 5 given the low exceedance frequency of 1 of 75 samples in the past 10 years and 1 of 30 in the past five years. Note that dibenzo(a,h)anthracene data will be collected as part of this CIMP at the downstream boundary of the ULAR EWMP area and by the DCTWRP. These data can be evaluated to determine if additional monitoring by the ULARWMAG is warranted in the future.
- Indeno(1,2,3-cd)Pyrene will not be monitored as part of this CIMP in LAR Reach 5 given the low exceedance frequency of 1 of 75 samples in the past 10 years and 1 of 30 in the past five years. Note that indeno(1,2,3-cd)pyrene data will be collected as part of this CIMP at the downstream boundary of the ULAR EWMP area and by the DCTWRP. These data can be evaluated to determine if monitoring by the ULARWMAG is warranted in the future.
- Nickel in LAR Reach 5 will not be monitored as part of this CIMP given the low exceedance frequency of 1 of 72 samples in the past 10 years and 1 of 30 in the past five years. Note that nickel data will be collected as part of this CIMP at the downstream boundary of the ULAR EWMP area and by the DCTWRP. These data can be evaluated to determine if monitoring by the ULARWMAG is warranted in the future.

- Mercury in Rio Hondo will not be monitored as part of this CIMP given the low exceedance frequency of 2 of 74 samples in the past 10 years and 1 of 41 in the past five years and that it is potentially a sample contamination issue. Note that mercury data will be collected as part of the CIMP at the downstream boundary of the ULAR EWMP area and by the Whittier Narrows WRP. These data can be evaluated to determine if monitoring by the ULARWMAG is warranted in the future.
- Mercury in BWC will not be monitored as part of this CIMP given the low exceedance frequency of 18 of 251 samples in the past 10 years and 1 of 99 in the past five years and that it is potentially a sample contamination issue. Note that mercury data will be collected as part of the CIMP at the downstream boundary of the ULAR EWMP area and by the BWRP. These data can be evaluated to determine if monitoring by the ULARWMAG is warranted in the future.
- All WBPCs which exceeded applicable receiving water limitations in the past 10 years, but not the past five years will not be monitored. If included in Table E-2 of the MRP, these constituents will be monitored at the LTA sites during the first year of monitoring. For constituents detected above the lowest applicable water quality objective during the first year of monitoring, future monitoring will be conducted and may be triggered upstream.

Table 13. Summary of Upper Los Angeles River Watershed Water Body Pollutant Categories for Mainstem Reaches

Class ⁽¹⁾	Constituents	LA River						
		1	2	3 (below LAG)	3 (above LAG)	4	5	6
Category 1A: WBPCs with past due or current Permit term TMDL deadlines <u>with exceedances</u> in the past 5 years. (I = Interim and F = Final Limits)								
Metals	Cadmium Total	I (Wet)						
Metals	Copper Dissolved	I (Wet)	I (Wet)			I (Wet)	I (Dry)	I (Wet)
Metals	Copper Total	I (Wet)	I (Wet)	I (Wet)		I (Wet)	I (Dry)	
Metals	Lead Dissolved	I (Wet/Dry)	I (Wet/Dry)	I (Wet/Dry)		I (Wet/Dry)		
Metals	Lead Total	I (Wet)	I (Wet)		I (Dry)			
Metals	Zinc Dissolved	I (Wet)	I (Wet)			I (Wet)		I (Wet)
Metals	Zinc Total	I (Wet)	I (Wet)	I (Wet)		I (Wet)		I (Wet)
Trash	Trash	I/F	I/F	I/F	I/F	I/F	I/F	I/F
HO/CO	Sediment: DDTs, PCBs, PAHs ⁽²⁾	I						
Metals	Sediment: Copper, Lead, Zinc ⁽²⁾	I						
Category 1B: WBPCs with TMDL deadlines beyond the Permit term <u>with exceedances</u> in the past 5 years. (I = Interim and F = Final Limits)								
Bacteria	<i>E. Coli</i>	I/F (Wet/Dry)	I/F (Wet/Dry)	I/F (Wet/Dry)	I/F (Wet/Dry)	I/F (Wet/Dry)	I/F (Wet/Dry)	I/F (Wet/Dry)
Metals	Cadmium Total	F (Wet)						
Metals	Copper Dissolved	F (Wet)	F (Wet)			F (Wet)	F (Dry)	F (Wet)
Metals	Copper Total	F (Wet)	F (Wet)	F (Wet)		F (Wet)	F (Dry)	
Metals	Lead Dissolved	F (Wet/Dry)	F (Wet/Dry)	F (Wet/Dry)		F (Wet/Dry)		
Metals	Lead Total	F (Wet)	F (Wet)		F (Dry)			
Metals	Zinc Dissolved	F (Wet)	F (Wet)			F (Wet)		F (Wet)
Metals	Zinc Total	F (Wet)	F (Wet)	F (Wet)		F (Wet)		F (Wet)
HO/CO	Sediment: DDTs, PCBs, PAHs ⁽²⁾	F						
Metals	Sediment: Copper, Lead, Zinc ⁽²⁾	F						
Category 1C: WBPCs addressed in USEPA TMDL without a Regional Board Adopted Implementation Plan.								
None								
Category 1D: WBPCs with past due or current Permit term TMDL deadlines but <u>have not exceeded in past 5 years.</u>								
Metals	Cadmium Total		I (Wet NS)	I (Wet)	I (Wet NS)	I (Wet NS)	I (Wet NS)	I (Wet NS)

Class ⁽¹⁾	Constituents	LA River						
		1	2	3 (below LAG)	3 (above LAG)	4	5	6
Metals	Copper Dissolved	I (Dry)	I (Dry)	I (Wet/Dry)	I (Dry/Wet NS)	I (Dry)	I (Wet NS)	I (Dry)
Metals	Copper Total	I (Dry)	I (Dry)	I (Dry)	I (Wet/Dry)	I (Dry)	I (Wet NS)	I (Wet/Dry)
Metals	Lead Dissolved				I (Dry/Wet NS)		I (Dry/Wet NS)	I (Wet/Dry)
Metals	Lead Total	I (Dry)	I (Dry)	I (Wet/Dry)	I (Wet)	I (Wet/Dry)	I (Dry/Wet NS)	I (Wet/Dry)
Metals	Zinc Dissolved			I (Wet)	I (Wet NS)		I (Wet NS)	
Metals	Zinc Total				I (Wet)		I (Wet NS)	
Nutrients	Ammonia as N	F (Dry/Wet)	F (Dry/Wet NS)	F (Dry/Wet)	F (Dry/Wet)	F (Dry/Wet)	F (Dry/Wet)	F (Dry/Wet)
Nutrients	Nitrate as N	F	F	F	F	F	F	F
Nutrients	Nitrite as N	F	F	F	F	F	F	F
Nutrients	Nitrogen (NO3-N+NO2-N)	F	F	F	F	F	F	F
Category 2A: 303(d) Listed WBPCs or WBPCs that meet 303(d) Listing requirements with exceedances in the past 5 years.								
CO	2,3,7,8-TCDD (Dioxin)			Dry				
CO	Bis(2-ethylhexyl)Phthalate	Dry						
CO	Diazinon						Dry	
Metals	Selenium						Dry	Dry
Salts	Chloride						Dry	Dry
Salts	Sulfate						Dry	Dry
Salts	TDS						Dry	
TBD	Cyanide	303 Dry/Wet						
TBD	pH	Dry						
Category 2B: 303(d) Listed WBPCs or WBPCs that meet 303(d) Listing requirements that are not a “pollutant”³ with exceedances in the past 5 years.								
TBD	pH		Dry					
Category 2C: 303(d) Listed WBPCs or WBPCs that meet 303(d) Listing requirements but have not exceeded in past 5 years.								
Metals	Mercury Total	Dry	Dry/Wet (NS)	Dry	Dry	Dry/Wet (NS)		Dry
Metals	Thallium Total							Dry (NS)

Class ⁽¹⁾	Constituents	LA River						
		1	2	3 (below LAG)	3 (above LAG)	4	5	6
Salts	TDS							Dry (NS)
TBD	Oil		Delist				Delist	
CO	Diazinon	Wet (Delist)						
Category 3A: All other WBPCs with exceedances in the past 5 years.								
CO	2,3,7,8-TCDD (Dioxin)			Wet	Wet			
CO	Bis(2-ethylhexyl)Phthalate	Wet						
CO	Diazinon					Dry		
CO	Dibenzo(a,h)Anthracene						Dry	
CO	Indeno(1,2,3-cd)Pyrene						Dry	
HO	4,4-DDD						Dry	
HO	4,4-DDE						Dry	
Metals	Nickel Total						Dry	
Metals	Selenium Total	Dry						
Metals	Zinc Dissolved	Dry						
Metals	Zinc Total	Dry		Dry				
Salts	Sulfate					Dry		
TBD	Cyanide					Dry	Dry	
TBD	Dissolved Oxygen						Dry	
Category 3B: All other WBPCs that are not a "pollutant"³ with exceedances in the past 5 years.								
TBD	pH			Dry	Dry		Dry	
Category 3C: All other WBPCs that have exceeded in the past 10 years, but not in past 5 years.								
CO	2,3,7,8-TCDD (Dioxin)				Dry			Dry (NS)
CO	Benzo(a)Anthracene			Dry				
CO	beta-BHC							
CO	Bis(2-ethylhexyl)Phthalate			Dry	Dry		Dry	
CO	Chrysene			Dry		Dry		Dry (NS)
CO	Dibenzo(a,h)Anthracene			Dry	Dry			
CO	Dichlorobromomethane			Wet				

Class ⁽¹⁾	Constituents	LA River						
		1	2	3 (below LAG)	3 (above LAG)	4	5	6
CO	Indeno(1,2,3-cd)Pyrene			Dry	Dry			
HO	Heptachlor			Wet			Dry	
Metals	Mercury Total	Wet		Wet	Wet		Dry	Wet (NS)
Metals	Nickel Total				Dry			
Metals	Selenium Total				Dry	Dry		
Metals	Thallium Total	Dry	Dry (NS)	Dry	Dry	Dry		
Metals	Zinc Total					Dry		
Salts	Sulfate				Dry			
Salts	TDS					Dry		
TBD	Chlorine (Total)			Dry	Dry	Dry	Dry	Dry
TBD	Cyanide			Dry	Dry			Dry
TBD	Dissolved Oxygen	Wet		Dry		Dry		Dry
TBD	pH	Wet	Wet (NS)					

1. Pollutants are considered in a similar class if they have similar fate and transport mechanisms, can be addressed via the same types of control measures, and within the same timeline already contemplated as part of the EWMP for the TMDL. (Permit pg. 49, footnote 21).
2. Pollutants associated with the Dominguez Channel and Greater Los Angeles and Long Beach Harbor Waters Toxic Pollutants TMDL were identified as applicable to Reach 1 of the LA River as the nearest downstream receiving water segment from the EWMP area.
3. While pollutants may be contributing to the impairment, it currently is not possible to identify the *specific* pollutant/stressor.

Note that unless explicitly stated as sediment, constituents are associated with the water column.

I/F = Denotes where the Permit includes interim (I) and/or final (F) effluent and/or receiving water limitations.

NS = Not sampled in the given condition within the past five years.

303 = WBPC on the 2010 303(d) List where the listing was confirmed during data analysis.

Delist = WBPC on the 2010 303(d) List that could now be delisted.

HO = Historical Organics – inclusive of historical pesticides.

CO = Current Organics – inclusive of current use pesticides and other organics such as PAHs.

TBD = To be determined – used for conditions (pH and dissolved oxygen) that are not pollutants, per se.

Table 14. Summary of Upper Los Angeles River Watershed Water Body Pollutant Categories for Tributaries

Class ⁽¹⁾	Constituents	Compton Creek	Rio Hondo			Arroyo Seco	Verdugo Wash	Burbank Western Channel	Tujunga Wash
			1	2	3				
Category 1A: WBPCs with past due or current Permit term TMDL deadlines <u>with exceedances</u> in the past 5 years. (I = Interim and F = Final Limits)									
Metals	Copper Dissolved		I (Dry)					I (Dry)	I (Dry)
Metals	Copper Total	I (Dry)	I (Dry)				I (Wet) NS)	I (Dry)	I (Dry)
Metals	Lead Dissolved		I (Dry)			I (Wet/Dry)			
Metals	Lead Total	I (Dry)	I (Dry)						I (Dry)
Metals	Zinc Total		I (Dry)						
Nutrients	Ammonia as N								F (Dry)
Nutrients	Nitrate as N							F (Dry)	
Nutrients	Nitrite as N					F (Dry)		F (Dry)	
Trash	Trash	I/F	I/F	I/F		I/F	I/F	I/F	I/F
Category 1B: WBPCs with TMDL deadlines beyond the Permit term <u>with exceedances</u> in the past 5 years. (I = Interim and F = Final Limits)									
Bacteria	<i>E. Coli</i>	I/F (Wet/Dry)	I/F (Wet/Dry)	I/F (Wet/Dry)	I/F (Wet/Dry)	I/F (Wet/Dry)	I/F (Wet/Dry)	I/F (Wet/Dry)	I/F (Wet/Dry)
Metals	Copper Dissolved		F (Dry)					F (Dry)	F (Dry)
Metals	Copper Total	F (Dry)	F (Dry)				F (Wet) NS)	F (Dry)	F (Dry)
Metals	Lead Dissolved		F (Dry)			F (Wet/Dry)			
Metals	Lead Total	F (Dry)	F (Dry)						F (Dry)
Metals	Zinc Dissolved								
Metals	Zinc Total		F (Dry)						
Category 1C: WBPCs addressed in USEPA TMDL without a Regional Board Adopted Implementation Plan.									
	None								
Category 1D: WBPCs with past due or current Permit term TMDL deadlines <u>but have not exceeded</u> in past 5 years.									
Metals	Cadmium Total	I (Wet NS)	I (Wet NS)	I (Wet NS)		I (Wet NS)	I (Wet NS)	I (Wet NS)	I (Wet NS)
Metals	Copper Dissolved	I (Dry/Wet NS)	I (Wet NS)	I (NS)		I (Wet/Dry)	I (Wet)/(Dry NS)	I (Wet NS)	I (Wet NS)
Metals	Copper Total	I (Wet NS)	I (Wet NS)	I (NS)		I (Wet/Dry)	I (Dry NS)	I (Wet NS)	I (Wet NS)
Metals	Lead Dissolved	I (Dry/Wet NS)	I (Wet NS)	I (NS)			I (Wet/Dry NS)	I (Dry/Wet NS)	I (Dry)/Wet NS)

Class ⁽¹⁾	Constituents	Compton Creek	Rio Hondo			Arroyo Seco	Verdugo Wash	Burbank Western Channel	Tujunga Wash
			1	2	3				
Metals	Lead Total	I (Wet NS)	I (Wet NS)	I (NS)		I (Wet/Dry)	I (Wet/Dry NS)	I (Dry/Wet NS)	I (Wet NS)
Metals	Zinc Dissolved	I (Wet NS)	I (Dry/Wet NS)	I (Wet NS)		I (Wet)	I (Wet)	I (Wet NS)	I (Wet NS)
Metals	Zinc Total	I (Wet NS)	I (Wet NS)	I (Wet NS)		I (Wet)	I (Wet)	I (Wet NS)	I (Wet NS)
Nutrients	Ammonia as N	F (Dry/Wet NS)	F (Dry/Wet NS)	F (NS)		F (Dry/Wet NS)	F (NS)	F (NS)	F (Wet NS)
Nutrients	Nitrate as N	F	F	F (NS)		F	F (NS)	F (Wet)	F
Nutrients	Nitrite as N	F	F	F (NS)		F (Wet NS)	F (NS)	F (Wet)	F
Nutrients	Nitrogen (NO3-N+NO2-N)	F	F	F (NS)		F	F (NS)	F	F
Category 2A: 303(d) Listed WBPCs or WBPCs that meet 303(d) Listing requirements with exceedances in the past 5 years.									
CO	2,3,7,8-TCDD (Dioxin)							Dry	
CO	Bis(2-ethylhexyl) Phthalate							Dry	
CO	Chlorodibromomethane							Dry	
Salts	Chloride								Dry
Metals	Copper Total				Dry				
TBD	Cyanide			303 Dry (NS)					
TBD	Dissolved Oxygen				Dry				
TBD	pH				Dry				
Category 2B: 303(d) Listed WBPCs or WBPCs that meet 303(d) Listing requirements that are not a "pollutant"² with exceedances in the past 5 years.									
TBD	Benthic-Macroinvertebrates	303				303			
Category 2C: 303(d) Listed WBPCs or WBPCs that meet 303(d) Listing requirements but have not exceeded in past 5 years.									
CO	Bis(2-ethylhexyl) Phthalate			Dry /Wet (NS)		Wet (NS)	Dry/Wet (NS)	Wet (NS)	
Metals	Selenium Total							Delist	
TBD	Chlorine (Total)							Wet	

Class ⁽¹⁾	Constituents	Compton Creek	Rio Hondo			Arroyo Seco	Verdugo Wash	Burbank Western Channel	Tujunga Wash
			1	2	3				
TBD	Cyanide							Delist	
Category 3A: All other WBPCs with exceedances in the past 5 years.									
CO	Benzo(a)Pyrene				Dry			Dry	
CO	Benzo(b)Fluoranthene							Dry	
CO	Benzo(k)Fluoranthene				Dry				
CO	Chrysene				Dry				
CO	Diazinon				Dry				
CO	Dibenzo(a,h)Anthracene				Dry				
CO	Indeno(1,2,3-cd)Pyrene				Dry				
CO	Chlorpyrifos	Dry							
Metals	Mercury Total							Dry	
Metals	Zinc Total								Dry
Salts	Chloride	Dry						Dry	
Salts	TDS							Dry	Dry
TBD	Chlorine (Total)							Dry	
Category 3B: All other WBPCs that are not a "pollutant"² with exceedances in the past 5 years.									
	None								
Category 3C: All other WBPCs that have exceeded in the past 10 years, but not in past 5 years.									
CO	beta-BHC							Dry	
CO	Bis(2-ethylhexyl) Phthalate					Dry (NS)			
CO	Diazinon			Wet (NS)					
HO	Heptachlor							Dry	
Metals	Cadmium Total							Dry	Dry
Metals	Copper Dissolved			Dry (NS)					
Metals	Copper Total			Dry (NS)					
Metals	Lead Total			Dry (NS)					

Class ⁽¹⁾	Constituents	Compton Creek	Rio Hondo			Arroyo Seco	Verdugo Wash	Burbank Western Channel	Tujunga Wash
			1	2	3				
Metals	Mercury Total	Dry/Wet (NS)			Dry	Wet (NS)	Wet (NS)	Wet (NS)	Dry
Metals	Thallium Total							Dry	
Metals	Zinc Total						Dry (NS)	Dry	
Salts	Chloride				Dry				
TBD	pH			Dry (NS)/Wet (NS)				Dry/Wet (NS)	

1. Pollutants are considered in a similar class if they have similar fate and transport mechanisms, can be addressed via the same types of control measures, and within the same timeline already contemplated as part of the EWMP for the TMDL. (Permit pg. 49, footnote 21).
2. Pollutants associated with the Dominguez Channel and Greater Los Angeles and Long Beach Harbor Waters Toxic Pollutants TMDL were identified as applicable to Reach 1 of the LA River as the nearest downstream receiving water segment from the EWMP area.
3. While pollutants may be contributing to the impairment, it currently is not possible to identify the *specific* pollutant/stressor.

Note that unless explicitly stated as sediment, constituents are associated with the water column.

I/F = Denotes where the Permit includes interim (I) and/or final (F) effluent and/or receiving water limitations.

NS = Not sampled in the given condition within the past five years.

303 = WBPC on the 2010 303(d) List where the listing was confirmed during data analysis.

Delist = WBPC on the 2010 303(d) List that could now be delisted.

HO = Historical Organics – inclusive of historical pesticides.

CO = Current Organics – inclusive of current use pesticides and other organics such as PAHs.

TBD = To be determined – used for conditions (pH and dissolved oxygen) that are not pollutants, per se.

Table 15. Summary of Upper LA River WMA Group Water Body-Pollutant Categories for LA River Reach 5 and 6 Tributaries

Class ⁽¹⁾	Constituents	Bell Creek	Bull Creek	Caballero Creek	Aliso Canyon Wash	McCoy Canyon	Dry Canyon
Category 1A: WBPCs with past due or current Permit term TMDL deadlines with exceedances in the past 5 years. (I = Interim and F = Final Limits)							
Trash	Trash	I/F	I/F	I/F	I/F	I/F	I/F
Category 1B: WBPCs with TMDL deadlines beyond the Permit term with exceedances in the past 5 years. (F = Final Limits)							
Bacteria	<i>E. Coli</i>	I/F (Wet/Dry)	I/F (Wet/Dry)	I/F (Wet/Dry)	I/F (Wet/Dry)	I/F (Wet/Dry)	I/F (Wet/Dry)
Category 1D: WBPCs with past due or current Permit term TMDL deadlines but have not exceeded in past 5 years. (I = Interim and F = Final Limits)							
Metals	Cadmium Total	I (Wet NS)	I (Wet NS)	I (Wet NS)	I (Wet NS)	I (Wet NS)	I (Wet NS)
Metals	Copper Dissolved	I (NS)	I (Dry/Wet NS)	I (NS)	I (Dry)/(Wet NS)	I (NS)	I (NS)
Metals	Copper Total	I (NS)	I (Dry/Wet NS)	I (NS)	I (Dry)/(Wet NS)	I (NS)	I (NS)
Metals	Lead Dissolved	I (NS)	I (Dry/Wet NS)	I (NS)	I (Dry/Wet NS)	I (NS)	I (NS)
Metals	Lead Total	I (NS)	I (Dry/Wet NS)	I (NS)	I (Dry/Wet NS)	I (NS)	I (NS)
Metals	Zinc Dissolved	I (Wet NS)	I (Dry/Wet NS)	I (Wet NS)	I (Wet NS)	I (Wet NS)	I (Wet NS)
Metals	Zinc Total	I (Wet NS)	I (Dry)/(Wet NS)	I (Wet NS)	I (Wet NS)	I (Wet NS)	I (Wet NS)
Nutrients	Ammonia as N	F (NS)	F (Dry/Wet NS)	F (NS)	F (Dry/Wet NS)	F (NS)	F (NS)
Nutrients	Nitrate as N	F (NS)	F	F (NS)	F	F (NS)	F (NS)
Nutrients	Nitrite as N	F (NS)	F	F (NS)	F	F (NS)	F (NS)
Nutrients	Nitrogen (NO ₃ -N+NO ₂ -N)	F (NS)	F	F (NS)	F	F (NS)	F (NS)
Category 2A: 303(d) Listed WBPCs or WBPCs that meet 303(d) Listing requirements with exceedances in the past 5 years.							
	None						
Category 2B: 303(d) Listed WBPCs or WBPCs that meet 303(d) Listing requirements that are not a “pollutant”² with exceedances in the past 5 years.							
	None						
Category 2C: 303(d) Listed WBPCs or WBPCs that meet 303(d) Listing requirements but have not exceeded in past 5 years.							
CO	Bis(2-ethylhexyl)Phthalate		Dry (NS)/Wet		Dry (NS)/Wet		
Metals	Selenium Total			Dry (NS)	Dry		
Category 3A: All other WBPCs with exceedances in the past 5 years.							
Salts	Sulfate				Dry		
Salts	TDS				Dry		
Category 3B: All other WBPCs that are not a “pollutant”² with exceedances in the past 5 years.							
	None						

Class ⁽¹⁾	Constituents	Bell Creek	Bull Creek	Caballero Creek	Aliso Canyon Wash	McCoy Canyon	Dry Canyon
Category 3C: All other WBPCs that have exceeded in the past 10 years, but not in past 5 years.							
CO	Diazinon				Wet (NS)		
Metals	Cadmium Total			Dry (NS)			
Metals	Copper Total			Dry (NS)			
Metals	Lead Total			Dry (NS)			
Metals	Mercury Total			Dry (NS)			
Metals	Nickel Total			Dry (NS)			
Metals	Zinc Total			Dry (NS)			
TBD	Cyanide		Wet (NS)		Wet (NS)		

1. Pollutants are considered in a similar class if they have similar fate and transport mechanisms, can be addressed via the same types of control measures, and within the same timeline already contemplated as part of the EWMP for the TMDL. (Permit pg. 49, footnote 21).
2. Pollutants associated with the Dominguez Channel and Greater Los Angeles and Long Beach Harbor Waters Toxic Pollutants TMDL were identified as applicable to Reach 1 of the LA River as the nearest downstream receiving water segment from the EWMP area.
3. While pollutants may be contributing to the impairment, it currently is not possible to identify the *specific* pollutant/stressor.

Note that unless explicitly stated as sediment, constituents are associated with the water column.

I/F = Denotes where the Permit includes interim (I) and/or final (F) effluent and/or receiving water limitations.

NS = Not sampled in the given condition within the past five years.

303 = WBPC on the 2010 303(d) List where the listing was confirmed during data analysis.

Delist = WBPC on the 2010 303(d) List that could now be delisted.

HO = Historical Organics – inclusive of historical pesticides.

CO = Current Organics – inclusive of current use pesticides and other organics such as PAHs.

TBD = To be determined – used for conditions (pH and dissolved oxygen) that are not pollutants, per se.

Table 16. Summary of Upper Los Angeles River Watershed Water Body Pollutant Categories for Lakes

Class ⁽¹⁾	Constituent	Lake		
		Legg	Calabasas	Echo Park
Category 1A: WBPCs with past due or current Permit term TMDL deadlines with exceedances in the past 5 years. (I = Interim and F = Final Limits)				
Trash	Trash	I/F		
Category 1C: WBPCs addressed in USEPA TMDL without a Regional Board Adopted Implementation Plan.				
Nutrients	Total-P	X	X	X
	Total-N	X	X	X
Trash	Trash			X
Legacy	PCBs (water and sediment)			X
	Chlordane (water and sediment)			X
	Dieldrin (water and sediment)			X

1. Pollutants are considered in a similar class if they have similar fate and transport mechanisms, can be addressed via the same types of control measures, and within the same timeline already contemplated as part of the EWMP for the TMDL. (Permit pg. 49).

I/F – Denotes where the Permit includes interim (I) and/or final (F) limitations.

Note that unless explicitly stated as sediment, constituents are associated with the water column.

4 LACFCD Background Information

In 1915, the Los Angeles County Flood Control Act established the LACFCD and empowered it to manage flood risk and conserve stormwater for groundwater recharge. In coordination with the United States Army Corps of Engineers the LACFCD developed and constructed a comprehensive system that provides for the regulation and control of flood waters through the use of reservoirs and flood channels. The system also controls debris, collects surface storm water from streets, and replenishes groundwater with storm water and imported and recycled waters. The LACFCD covers the 2,753 square-mile portion of Los Angeles County south of the east-west projection of Avenue S, excluding Catalina Island. It is a special district governed by the County of Los Angeles Board of Supervisors, and its functions are carried out by the Los Angeles County Department of Public Works. The LACFCD service area is shown in **Figure 5**.

Unlike cities and counties, the LACFCD does not own or operate any municipal sanitary sewer systems, public streets, roads, or highways. The LACFCD operates and maintains storm drains and other appurtenant drainage infrastructure within its service area. The LACFCD has no planning, zoning, development permitting, or other land use authority within its service area. The permittees that have such land use authority are responsible under the Permit for inspecting and controlling pollutants from industrial and commercial facilities, development projects, and development construction sites. (Permit, Part II.E)

The Permit language clarifies the unique role of the LACFCD in storm water management programs: “[g]iven the LACFCD’s limited land use authority, it is appropriate for the LACFCD to have a separate and uniquely-tailored storm water management program. Accordingly, the storm water management program minimum control measures imposed on the LACFCD in Part VI.D of this Order differ in some ways from the minimum control measures imposed on other Permittees. Namely, aside from its own properties and facilities, the LACFCD is not subject to the Industrial/Commercial Facilities Program, the Planning and Land Development Program, and the Development Construction Program. However, as a discharger of storm and non-storm water, the LACFCD remains subject to the Public Information and Participation Program and the Illicit Connections and Illicit Discharges Elimination Program. Further, as the owner and operator of certain properties, facilities and infrastructure, the LACFCD remains subject to requirements of a Public Agency Activities Program.” (Permit, Part II.F)

Consistent with the role and responsibilities of the LACFCD under the Permit, the EWMPs and CIMPs reflect the opportunities that are available for the LACFCD to collaborate with permittees having land use authority over the subject watershed area. In some instances, the opportunities are minimal, however the LACFCD remains responsible for compliance with certain aspects of the MS4 permit as discussed above.

During the development of the CIMP, LACFCD infrastructure was evaluated for monitoring opportunities. The LACFCD will be collaborating with the groups for all of the monitoring.



Figure 5. Los Angeles County Flood Control District Service Area

5 Watershed Background References

County of Los Angeles Department of Public Works, City of Los Angeles WPD, and City of Calabasas. 2005. *Monitoring Work Plan to Assess Nutrients Loading from the Municipal Separate Storm Sewer System in Los Angeles River Watershed*. March 2005.

LARWQCB. 2002. *Amendments to the Water Quality Control Plan – Los Angeles Region for the Los Angeles River Trash TMDL*. Attachment A to Resolution No. 2001-013. Adopted September 19, 2001. Effective August 1, 2002. Revised September 23, 2008.

LARWQCB. 2003. *Amendment to the Water Quality Control Plan – Los Angeles Region to Incorporate the Los Angeles River Nitrogen Compounds and Related Effects TMDL*. Attachment A to Resolution No. 03-009. Adopted July 10, 2003. Effective March 23, 2004. Revised June 4, 2013.

LARWQCB. 2007. *Amendment to the Water Quality Control Plan – Los Angeles Region to Incorporate the Los Angeles River and Tributaries Metals TMDL*. Attachment A to Resolution No. 2007-014. Adopted September 6, 2007. Effective October 29, 2008. Revised November 3, 2011.

LARWQCB. 2010. *Amendment to the Water Quality Control Plan – Los Angeles Region to Incorporate the Los Angeles River Watershed Bacteria TMDL*. Attachment A to Resolution No. R10-007. Adopted July 9, 2010. Effective March 23, 2012.

LARWQCB. 2011. *Amendment to the Water Quality Control Plan – Los Angeles Region to Incorporate the Total Maximum Daily Load for Toxic Pollutants in Dominguez Channel and Greater Los Angeles and Long Beach Harbor Waters*. Attachment A to Resolution No. R11-008. Adopted May 5, 2011. Effective March 23, 2012.

Legg Lake Trash TMDL Jurisdictional Group. 2008. *Trash Monitoring & Reporting Plan: Legg Lake Trash TMDL*. September 5, 2008.

Los Angeles River Metals TMDL Technical Committee. 2008. *Los Angeles River Metals TMDL Coordinated Monitoring Plan*. Chaired by the City and County of Los Angeles. March 25, 2008.

Los Angeles River Watershed Bacteria TMDL Technical Committee. 2013. *Coordinated Monitoring Plan for Los Angeles River Watershed Bacteria TMDL – Compliance Monitoring*. Chaired by the City of Los Angeles. March 23, 2013.

USEPA. 2007. *Total Maximum Daily Loads for Metals and Selenium – San Gabriel River and Impaired Tributaries*. USEPA Region 9. March 26, 2007.

USEPA. 2012. *Los Angeles Area Lakes Total Maximum Daily Loads for Nitrogen, Phosphorus, Mercury, Trash, Organochlorine Pesticides and PCBs*. USEPA Region 9. March 26, 2012.

Attachment B. Monitoring Location Fact Sheets

Attachment B presents the monitoring location fact sheets for the receiving water and stormwater outfall monitoring sites identified in this CIMP. For each site, the monitoring location fact sheets consist of relevant information (e.g., coordinates), a general description, aerial satellite imagery, a photograph, and land use information. Additionally, an analysis evaluating stormwater variability and the appropriateness of the number of outfall sites selected is presented.

6 Receiving Water Sites

The receiving water monitoring sites in the ULARWMA EWMP area and the type of monitoring (e.g., long term assessment or TMDL) that will be conducted at each site are summarized in **Table 17**. The locations of the monitoring sites are shown in **Figure 6**. Each constituent required for monitoring by the MRP is addressed by at least one of the two types of receiving water monitoring. The following subsections present details for the receiving water monitoring sites. Note that the specific constituents that will be monitored at each site are presented in the CIMP. Factsheets for each site are presented in the following subsection.

Table 17. Summary of Receiving Water Monitoring Sites

Site ID	Waterbody/Location	Previous Site Name Used in TMDL Monitoring Programs	Coordinates		Monitoring Type	
			Latitude	Longitude	LTA	TMDL
LAR_02_WAS	LA River Reach 2 upstream of Washington Blvd	LAR1-8	34.018436	-118.223499	X	X
LAR_03_FIG	LA River Reach 3 at Figueroa St	LAR1-7; LARB-03	34.081249	-118.227546		X
LAR_03_ZOO ⁽¹⁾	LA River Reach 3 at Zoo Dr	LAR1-6	34.155683	-118.281270		X
LAR_04_TUJ	LA River Reach 4 at Tujunga Ave	LAR1-4; LARB-04	34.140977	-118.379127	X	X
LAR_05_SEP ⁽²⁾	LA River Reach 5 at Sepulveda Blvd	LAR1-2	34.161559	-118.465969		X
LAR_06_WHI	LA River Reach 6 at White Oak Ave	LAR1-1	34.185076	-118.518735		X
CC_ELS	Compton Creek upstream of El Segundo Blvd	N/A	33.917332	-118.249956		X
RH_SLA	Rio Hondo at Slauson Ave	N/A	33.975272	-118.118805		X
AS_SAN	Arroyo Seco at San Fernando Rd	LAR2-3; LARB-08	34.080470	-118.224970		X
VW_CON	Verdugo Wash at Concord St	LAR2-2; LARB-09	34.156724	-118.271240		X
BWC_RIV ⁽³⁾	Burbank Western Channel at Riverside Dr	LAR1-5; LARB-10	34.160714	-118.305020		X
TW_MOO	Tujunga Wash at Moorpark St	LAR1-3; LARB-11	34.151206	-118.395564		X
BUL_VIC ⁽⁴⁾	Bull Creek at Victory Blvd	LARB-12	34.186770	-118.497780		X
ACW_VAN	Aliso Canyon Wash at Vanowen St	LARB-13	34.193615	118.543966		X
MCC_VAL	McCoy Canyon Creek at Valley Circle Blvd	LARB-14	34.163094	-118.637946		X
DCC_VEN	Dry Canyon Creek at Ventura Blvd	LARB-15	34.161533	-118.634355		X
BEL_FAL	Bell Creek at Fallbrook Ave	LARB-16	34.197489	-118.623553		X
EPL_1	Echo Park Lake	N/A	34.073056	-118.260783		X
EPL_2			34.071242	-118.260734		X
LEG_LAK	Legg Lake	N/A	Varies	Varies		X
CAL_LAK	Lake Calabasas	N/A	Varies	Varies		X

1. For improved coordination, this site could be moved to Colorado Blvd co-located with a site currently monitored by the LAG WRP.
2. For improved coordination, this site could be moved to be co-located with a site currently being monitored by the DCT WRP.
3. For improved coordination, this site could be moved to be co-located with a site currently being monitored by the Burbank WRP.
4. For improved coordination, this site is co-located with a receiving water site currently being monitored by the DCT WRP.

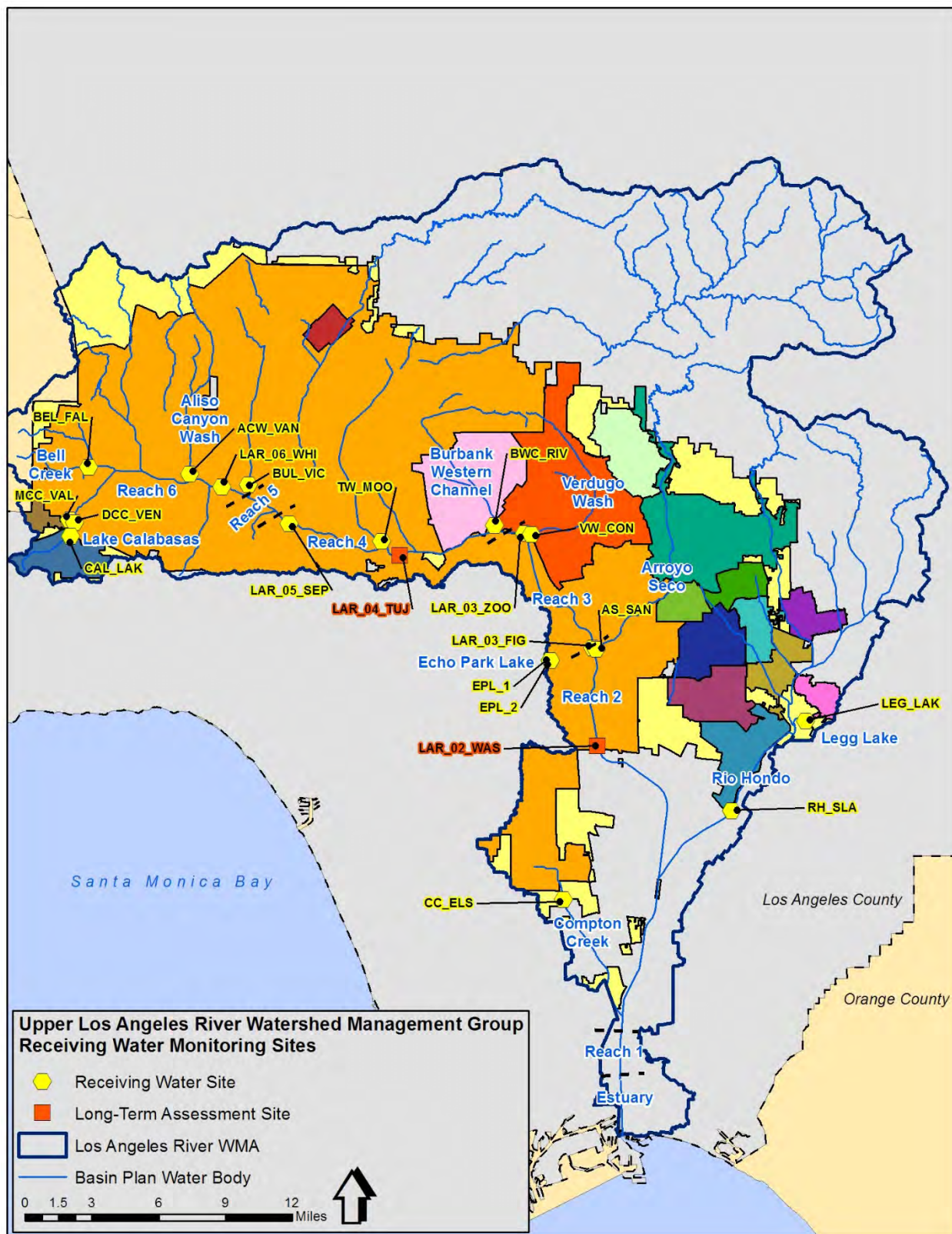

Figure 6. Overview of Receiving Water Monitoring Sites

6.1 Long Term Assessment Monitoring Site Fact Sheets

6.1.1 Los Angeles River Reach 2 Long Term Assessment Site

Waterbody Name	Waterbody Type	Site ID	Historical Site IDs	Site Type	Latitude	Longitude
LAR Reach 2	Main Stem	LAR_02_WAS	LAR1-8	LTA, TMDL	34.018436	-118.223499

General Description: Dry weather and wet weather LTA and TMDL monitoring site located in Reach 2 upstream of Washington Blvd and railroad bridge. The samples from this monitoring location would characterize the water quality of Reach 2 within the ULARWMAG area and identify additional constituents for monitoring at other locations within the watershed.



LAR_02_WAS Aerial View



LAR_02_WAS Ground-Level View

6.1.2 Los Angeles River Reach 4 Long Term Assessment Site

Waterbody Name	Waterbody Type	Site ID	Historical Site ID	Site Type	Latitude	Longitude
LAR Reach 4	Main Stem	LAR_04_TUJ	LAR1-4; LARB-04	TMDL	34.140977	-118.379127

General Description: Dry weather and wet weather LTA and TMDL monitoring site located in Reach 4 at Tujunga Ave. The samples from this monitoring site would characterize the water quality of Reach 4 and identify additional constituents for monitoring at other locations within the watershed.



LAR_04_TUJ Aerial View



LAR_04_TUJ Ground-Level View

6.2 TMDL Monitoring Site Fact Sheets

6.2.1 Los Angeles River Reach 3 TMDL Site at Figueroa

Waterbody Name	Waterbody Type	Site ID	Historical Site ID	Site Type	Latitude	Longitude
LAR Reach 3	Main Stem	LAR_03_FIG	LAR1-7; LARB-03	TMDL	34.081249	-118.227546

General Description: Dry weather and wet weather TMDL monitoring site located in Reach 3 at Figueroa St. The samples from this monitoring site would characterize the water quality of Reach 3 below the Los Angeles-Glendale Water Reclamation Plant.



LAR_03_FIG Aerial View



LAR_03_FIG Ground-Level View

6.2.2 Los Angeles River Reach 3 TMDL Site at Zoo

Waterbody Name	Waterbody Type	Site ID	Historical Site ID	Site Type	Latitude	Longitude
LAR Reach 3	Main Stem	LAR_03_ZOO	LAR1-6	TMDL	34.155683	-118.281270

General Description: Dry weather TMDL monitoring site located in Reach 3 near Zoo Dr. The samples from this monitoring site would characterize the water quality of Reach 3 above the Los Angeles-Glendale Water Reclamation Plant.



LAR_03_ZOO Aerial View



LAR_03_ZOO Ground-Level View

6.2.3 Los Angeles River Reach 5 TMDL Site

Waterbody Name	Waterbody Type	Site ID	Historical Site ID	Site Type	Latitude	Longitude
LAR Reach 5	Main Stem	LAR_05_SEP	LAR1-2	TMDL	34.161559	-118.465969

General Description: Dry weather TMDL monitoring site located in Reach 5 at Sepulveda Blvd. The samples from this monitoring site would characterize the water quality of Reach 5.

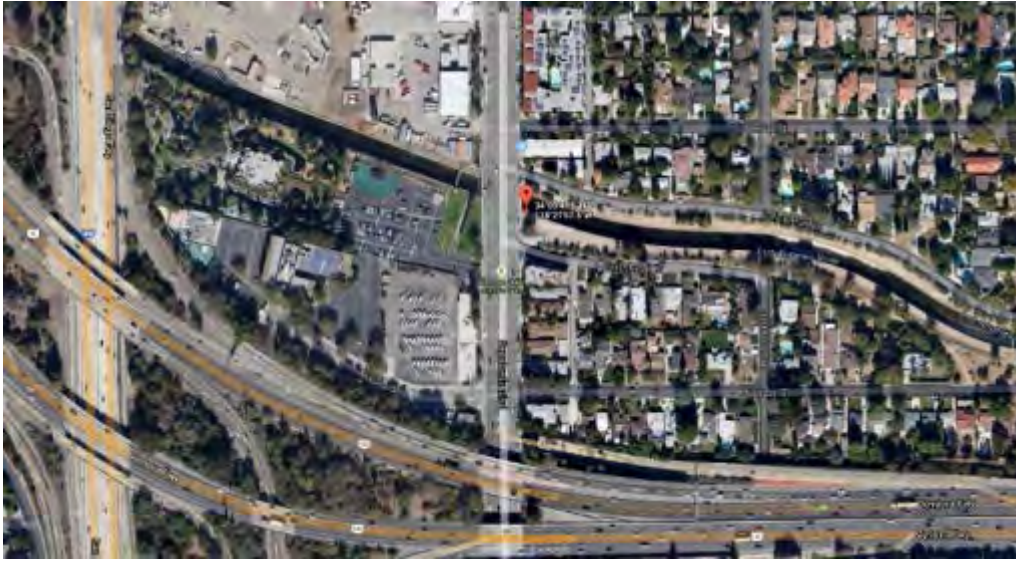

LAR_05_SEP Aerial View



LAR_05_SEP Ground-Level View

6.2.4 Los Angeles River Reach 6 TMDL Site

Waterbody Name	Waterbody Type	Site ID	Historical Site ID	Site Type	Latitude	Longitude
LAR Reach 6	Main Stem	LAR_06_WHI	LAR1-1	TMDL	34.185076	-118.518735

General Description: Dry weather and wet weather TMDL monitoring site located in Reach 6 at White Oak Ave. The samples from this monitoring site would characterize the water quality of Reach 6.



LAR_06_WHI Aerial View



LAR_06_WHI Ground-Level View

6.2.5 Compton Creek TMDL Site

Waterbody Name	Waterbody Type	Site ID	Historical Site ID	Site Type	Latitude	Longitude
Compton Creek	Tributary	CC_ELS	N/A	TMDL	33.917332	-118.249956

General Description: New dry weather TMDL monitoring site located in Compton Creek upstream of El Segundo Blvd. The samples from this monitoring site would characterize the water quality of Compton Creek within the ULARWMAG area.



CC_ELS Aerial View



CC_ELS Ground-Level View

6.2.6 Rio Hondo TMDL Site

Waterbody Name	Waterbody Type	Site ID	Historical Site ID	Site Type	Latitude	Longitude
Rio Hondo	Tributary	RH_SLA	N/A	TMDL	33.975272	-118.118805

General Description: New dry weather TMDL monitoring site located in Rio Hondo at Slauson Ave. The samples from this monitoring site would characterize the water quality of Rio Hondo within the ULARWMAG area. Samples to be taken upstream of pumping facility discharge on the east bank located immediately upstream from the Slauson Ave bridge



RH_SLA Aerial View



RH_SLA Ground-Level View

6.2.7 Arroyo Seco TMDL Site

Waterbody Name	Waterbody Type	Site ID	Historical Site ID	Site Type	Latitude	Longitude
Arroyo Seco	Tributary	AS_SAN	LAR2-3; LARB-08	TMDL	34.080470	-118.224970

General Description: Dry weather TMDL monitoring site located in Arroyo Seco at San Fernando Rd. The samples from this monitoring site would characterize the water quality of Arroyo Seco.



AS_SAN Aerial View



AS_SAN Ground-Level View

6.2.8 Verdugo Wash TMDL Site

Waterbody Name	Waterbody Type	Site ID	Historical Site ID	Site Type	Latitude	Longitude
Verdugo Wash	Tributary	VW_CON	LAR2-2; LARB-09	TMDL	34.156724	-118.271240

General Description: Dry weather TMDL monitoring site located in Verdugo Wash at Concord St. The samples from this monitoring site would characterize the water quality of Verdugo Wash.



VW_CON Aerial View



VW_CON Ground-Level View

6.2.9 Burbank Western Channel TMDL Site

Waterbody Name	Waterbody Type	Site ID	Historical Site ID	Site Type	Latitude	Longitude
Burbank Western Channel	Tributary	BWC_RIV	LAR1-5; LARB-10	TMDL	34.160714	-118.305020

General Description: Dry weather TMDL monitoring site located in Burbank Western Channel at Riverside Dr. The samples from this monitoring site would characterize the water quality of Burbank Western Channel.



BWC_RIV Aerial View



BWC_RIV Ground-Level View

6.2.10 Tujunga Wash TMDL Site

Waterbody Name	Waterbody Type	Site ID	Historical Site ID	Site Type	Latitude	Longitude
Tujunga Wash	Tributary	TW_MOO	LAR1-3; LARB-11	TMDL	34.151206	-118.395564

General Description: Dry weather TMDL monitoring site located in Tujunga Wash upstream of Moorpark St. The samples from this monitoring site would characterize the water quality of Tujunga Wash.



TW_MOO Aerial View



TW_MOO Ground-Level View

6.2.11 Bull Creek TMDL Site

Waterbody Name	Waterbody Type	Site ID	Historical Site ID	Site Type	Latitude	Longitude
Bull Creek	Tributary	BUL_VIC	LARB-12	TMDL	34.186770	-118.497780

General Description: Dry weather TMDL monitoring site located in Bull Creek at Victory Blvd upstream of the DCTWRP's discharge. The samples from this monitoring site would characterize the water quality of Bull Creek.



BUL_VIC Aerial View



BUL_VIC Ground-Level View

6.2.12 Aliso Canyon Wash TMDL Site

Waterbody Name	Waterbody Type	Site ID	Historical Site ID	Site Type	Latitude	Longitude
Aliso Canyon Wash	Tributary	ACW_VAN	LARB-13	TMDL	34.193615	-118.543966

General Description: Dry weather TMDL monitoring site located in Aliso Canyon Wash at Vanowen St. The samples from this monitoring site would characterize the water quality of Aliso Canyon Wash. Channel may be accessed at 34.190183, -118.534917.



ACW_VAN Aerial View



ACW_VAN Ground-Level View

6.2.13 McCoy Canyon Creek TMDL Site

Waterbody Name	Waterbody Type	Site ID	Historical Site ID	Site Type	Latitude	Longitude
McCoy Canyon Creek	Tributary	MCC_VAL	LARB-14	TMDL	34.163094	-118.637946

General Description: Dry weather TMDL monitoring site located in McCoy Canyon Creek at Valley Circle Blvd. Initially, this monitoring site is only intended to be monitored to satisfy the requirements of the Bacteria TMDL. As such, flow will not be monitored at this site.



MCC_VAL Aerial View



MCC_VAL Ground-Level View

6.2.14 Dry Canyon Creek TMDL Site

Waterbody Name	Waterbody Type	Site ID	Historical Site ID	Site Type	Latitude	Longitude
Dry Canyon Creek	Tributary	DCC_VEN	LARB-15	TMDL	34.161533	-118.634355

General Description: Dry weather TMDL monitoring site located in Dry Canyon Creek at Ventura Blvd. Initially, this monitoring site is only intended to be monitored to satisfy the requirements of the Bacteria TMDL. As such, flow will not be monitored at this site.



DCC_VEN Aerial View



DCC_VEN Ground-Level View

6.2.15 Bell Creek TMDL Site

Waterbody Name	Waterbody Type	Site ID	Historical Site ID	Site Type	Latitude	Longitude
Bell Creek	Tributary	BEL_FAL	LARB-16	TMDL	34.197489	-118.623553

General Description: Dry weather TMDL monitoring site located in Bell Creek at Fallbrook Ave. Initially, this monitoring site is only intended to be monitored to satisfy the requirements of the Bacteria TMDL. As such, flow will not be monitored at this site.



BEL_FAL Aerial View



BEL_FAL Ground-Level View

6.2.16 Echo Park Lake TMDL Sites

Waterbody Name	Waterbody Type	Site ID	Historical Site ID	Site Type	Latitude	Longitude
Echo Park Lake	Lake	EPL_1	N/A	TMDL	34.073056	-118.260783
		EPL_2			34.071242	-118.260734

General Description: Dry weather TMDL monitoring sites located in Echo Park Lake. Sampling may occur at any one and/or combination of these monitoring sites.



EPL_1 and EPL_2 Aerial View

6.2.17 Legg Lake TMDL Site

Waterbody Name	Waterbody Type	Site ID	Historical Site ID	Site Type	Latitude	Longitude
Legg Lake	Lake	LEG_LAK	N/A	TMDL	Varies	Varies

General Description: Dry weather TMDL monitoring site located in Legg Lake. The exact location of the monitoring site may vary due to hydrologic conditions affecting lake levels.



LEG_LAK Aerial View

6.2.18 Lake Calabasas TMDL Site

Waterbody Name	Waterbody Type	Site ID	Historical Site ID	Site Type	Latitude	Longitude
Lake Calabasas	Lake	CAL_LAK	N/A	TMDL	Varies	Varies

General Description: Dry weather TMDL monitoring site located in Lake Calabasas. The exact location of the monitoring site may vary due to hydrologic conditions affecting lake levels.



CAL_LAK Aerial View

7 Stormwater Outfall Sites

The following provides details on the stormwater outfall site selection process, an analysis evaluating the approach, as well as factsheets for each site. The ULARWMAG selected a coordinated approach to stormwater outfall monitoring where representative land use sites would be placed throughout the CIMP area. The ULARWMAG reviewed the HUC-12 boundaries (**Figure 7**) and found that placing sites solely based on those boundaries would result in stormwater outfall sites that were not directly tied to receiving water monitoring and would under represent areas where a HUC-12 spanned multiple tributaries and reaches of interest. For example, as shown in **Figure 7**, there is a large HUC-12 in the central part of the EWMP area that covers LA River Reaches 4, 5, and a part of 6, as well as Burbank Western Channel and Tujunga Wash. A HUC-12 based approach in this instance would suggest only one site for four major waterbodies. Additionally, a number of the northern HUC-12s span forest lands not covered by the MS4 Permit. As such, the one outfall per HUC-12 coordinated approach was slightly modified to a one outfall per major subwatershed approach. **Figure 8** displays the major subwatersheds subdividing the ULARWMAG area into the mainstem reaches and major tributaries addressed by the EWMP and CIMP for the purposes of outfall monitoring. These subwatersheds include: LA River Reaches 2 through 6, Compton Creek, Rio Hondo, Arroyo Seco, Verdugo Wash, Burbank Western Channel, and Tujunga Wash.

To support the selection of representative stormwater outfall monitoring sites, potential sites were identified during an initial desktop geographic information system (GIS) analysis for further evaluation. Three to four potential stormwater outfall monitoring sites were identified for most subwatersheds. However, due to the size and composition of the LA River Reach 6 subwatershed, eight potential stormwater outfall monitoring sites were identified. The desktop GIS analysis consisted of the following steps listed in sequential order: (1) identifying the locations of major outfalls (defined as greater than 36 inches), (2) calculating the percentage of each land use associated with the entire subwatershed area and identifying the major outfalls with estimated catchment areas that most closely match the land use breakdown of the subwatershed area in which the outfall is located, (3) identifying outfalls that appeared to be viable options given what could be seen using Google Maps© and Google Street View©, and (4) identifying outfalls that receive drainage from multiple jurisdictions.

A total of 48 potential stormwater outfall monitoring sites were visited. After the potential sites were visited, stormwater outfall monitoring sites were selected. The sites were selected based on an evaluation of the land uses draining to the outfall location, the jurisdictions draining to the outfall location (with an emphasis placed on receiving drainage from as many jurisdictions as possible), the safety and accessibility of the site, and the potential ability to use automatic sample compositor (autosampler) equipment at the location. The primary criterion for selecting the proposed monitoring sites was the representativeness of the land uses within the estimated outfall catchment area as compared to the subwatershed area as a whole. To best compare the land uses within the MS4 areas, the subwatershed area and outfall drainage area land uses were estimated only using open space characterized as golf courses, local parks, and regional parks for site selection.¹

¹ All land uses were calculated using the 2005 SCAG land use layer.

As previously mentioned, the size and composition of the LA River Reach 6 subwatershed is unique when compared with the other subwatershed areas. The Reach 6 subwatershed contains the largest portion of the ULARWMAG area. In addition, it is mostly composed of the City of Los Angeles and unincorporated Los Angeles County, with a small portion of the subwatershed consisting of the cities of Calabasas and Hidden Hills. Furthermore, the LA River Reach 6 subwatershed lies adjacent to the Reach 5 subwatershed, which is entirely composed of the City of Los Angeles and unincorporated Los Angeles County, and has a similar land use breakdown to these two jurisdictions' portion of Reach 6. Thus, to distinguish between the differences between areas of the LA River Reach 6 subwatershed and to capitalize on the similarities between areas of the LA River Reach 6 and Reach 5 subwatersheds, two outfall monitoring sites were selected for the Reach 6 subwatershed. One outfall monitoring site will be utilized to assess the cities of Calabasas and Hidden Hills and the other outfall monitoring site will be utilized to assess the areas of the cities of Calabasas and Los Angeles and the areas of the County of Los Angeles located within both the LA River Reach 5 and 6 subwatersheds.

The City of South El Monte is unique in that it is the only city in the ULARWMAG which has a greater area classified under the commercial/industrial land use than the residential land use. Also, the City of South El Monte discharges to two drains which subsequently discharge to the Legg Lake system. As a result, an additional stormwater outfall monitoring site will be located in the Rio Hondo subwatershed to determine the quality of stormwater being discharged by the City of South El Monte and to determine the quality of stormwater being discharged to the Legg Lake system. One outfall monitoring site was selected for all other subwatersheds yielding a total of 12 stormwater outfall monitoring sites.

The ULARWMAG encompasses sixteen HUC-12s. Of the sixteen HUC-12s, eight have outfall monitoring sites located within them, with six of the HUC-12s having one outfall monitoring site each, one HUC-12 having two outfall monitoring sites, and one HUC-12 having four outfall monitoring sites (**Table 18**). Although not all HUC-12s have outfall monitoring sites located within them, the portion of each HUC-12 which contains MS4 discharges is included within one of the major subwatersheds. This analysis shows that the proposed locations are adequately representative of the entire subwatershed (which includes the portions within the unmonitored HUC-12 drainage areas). As a result, the proposed locations within each subwatershed are representative of the portions of the unmonitored HUC-12 drainage areas which contain MS4 discharges.

Section 7.2 presents an analysis evaluating whether the number of stormwater outfall sites will provide sufficient information to determine the quality of stormwater discharges, determine if the discharge is in compliance with applicable WQBELs, and determine whether discharges are causing or contributing to exceedances of RWLs.

Table 18. Summary of Land Uses within the MS4 System by HUC-12, Number of Outfall Monitoring Sites and Corresponding Subwatersheds

HUC-12	Number of Outfall Monitoring Sites	Subwatershed
Alhambra Wash	2	Rio Hondo
Aliso Canyon Wash	0	LAR Reach 6
Arroyo Seco	1	Arroyo Seco
Bell Creek	1	LAR Reach 6
Browns Canyon Wash	0	LAR Reach 6
Bull Creek	0	LAR Reach 5
Chavez Ravine	1	LAR Reach 2
Compton Creek	1	Compton Creek
Eaton Wash	0	Rio Hondo
Little Tujunga Creek	0	Tujunga Wash
Lower Big Tujunga Creek	0	Tujunga Wash
Lower Pacoima Wash	0	Tujunga Wash
Santa Anita Wash	0	Rio Hondo
Scholl Canyon	1	LAR Reach 3
Tujunga Wash	4	LAR Reach 3, 4, 5, 6; Tujunga Wash; Burbank Western Channel
Verdugo Wash	1	Verdugo Wash

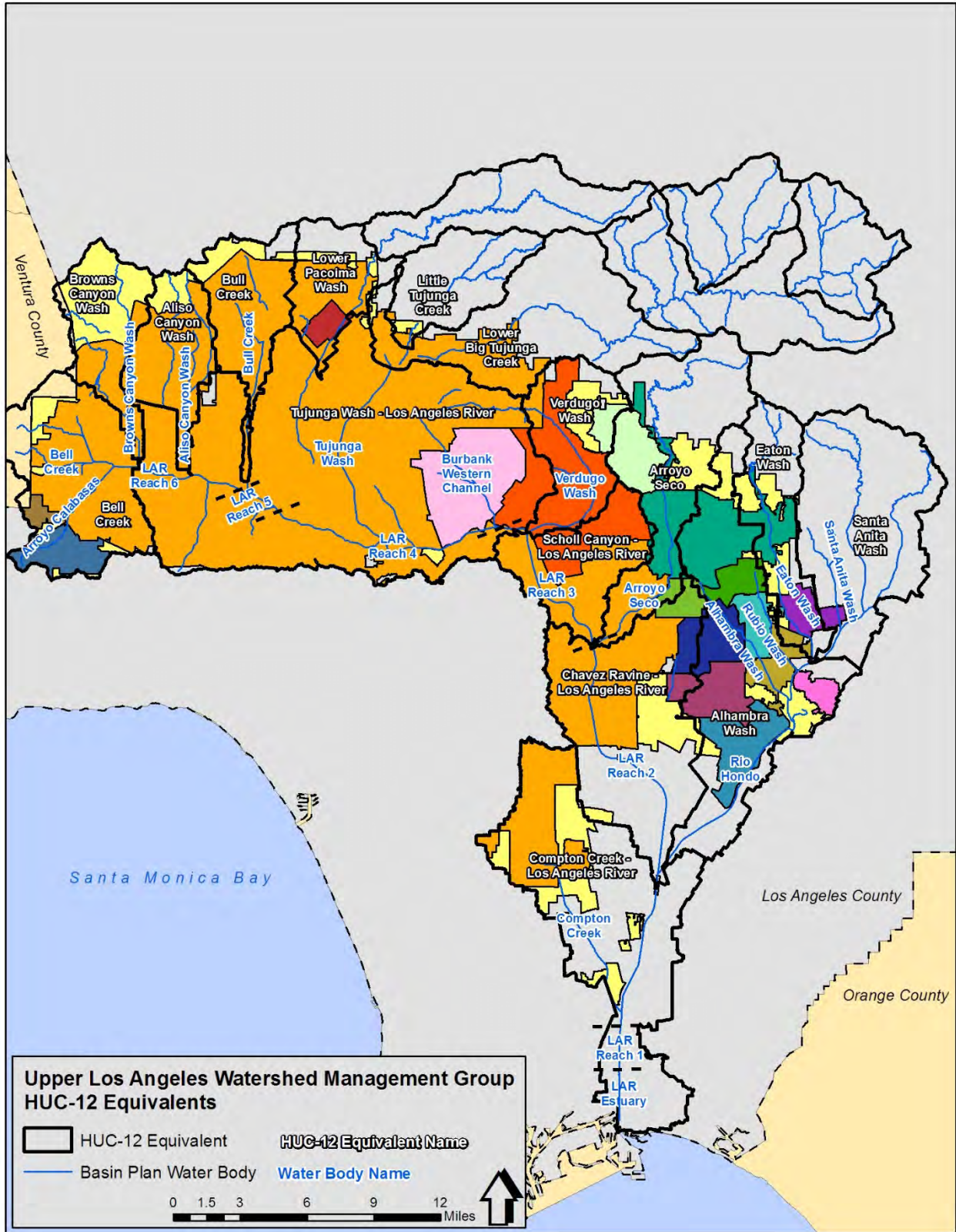

Figure 7. Upper Los Angeles River Watershed Management HUC-12 Boundaries

7.1 Summary of Stormwater Outfall Monitoring Sites

Summary information for the 12 stormwater outfall monitoring sites is presented in **Table 19** and the locations are shown on **Figure 9**. As stated previously, the principal criterion for site selection is that sites are representative of the land uses of the jurisdictions in the subwatershed in which the outfall is located. The drainages within the ULARWMAG EWMP area are comprised primarily of residential, commercial, and industrial land uses, and open space with minimal percentages of agriculture/nursery. The 12 sites were selected specifically to characterize runoff from drainages that are representative of the mix of these primary land uses in the various subwatersheds, and to minimize contributions from other land uses. Land use summaries for the subwatershed and each of the sites are listed in **Table 20**. **Section 7.2** of this Attachment presents an analysis evaluating whether the number of stormwater outfall sites will provide sufficient information to determine the quality of stormwater discharges, determine if the discharge is in compliance with applicable WQBELs, and determine whether discharges are causing or contributing to exceedances of RWLs.

Table 21 identifies the outfalls which would be considered representative of each of the ULARWMAG members' discharge to the various waterbodies in the ULAR EWMP area (i.e., LA River mainstem, tributaries, and lakes). That is, if an exceedance was observed in a given receiving water, the outfall data would be reviewed to determine if an individual ULARWMAG member caused or contributed to the exceedance. Specific constituents that will be monitored at each site are presented in the CIMP. As shown in **Table 19**, the LAR_06_SW_OLD is located in and only receives drainage from the City of Calabasas; however, as shown in **Table 20**, the land use summary for the LAR_06_SW_WIN site is more similar to the land use summary for the City of Calabasas presented in **Table 3** of the main body of this CIMP than the land use summary for the LAR_06_SW_OLD site. As such, both sites will be considered when assessing discharges related to the City of Calabasas.

Fact sheets are presented below to provide additional details of the sites as well as the alternate sites. Alternate sites provide additional sites that are approved for use should the selected sites pose unforeseen challenges for sampling that may require the use of a different site. Land use summaries for each of the alternate sites are also listed in **Table 20**. For the stormwater outfall monitoring sites, sampling may occur at a manhole located upstream of the current location where the outfall discharges to a receiving water if determined to be preferable.

Table 19. Primary Stormwater Outfall Monitoring Sites

Sub watershed	Site Name	Drain Name	Jurisdiction Where Site is Located	Jurisdictions Draining to the Site	Size	Shape	Latitude	Longitude
LA River Reach 2	LAR_02_SW_MAI	BI 0062 – Line A	City of LA	City of LA	147”	Rectangular	34.06720	-118.22424
LA River Reach 3	LAR_03_SW_COL	BI 9506 U01	City of LA	City of LA, Glendale	144”	Rectangular	34.13668	-118.27477
LA River Reach 4	LAR_04_SW_BUE	BI 0168 – Frederick St Drain	Burbank	Burbank	72”	Round	34.15319	-118.32545
LA River Reach 6	LAR_06_SW_WIN	BI 0477	City of LA	City of LA	108”	Rectangular	34.19097	-118.57072
LA River Reach 6	LAR_06_SW_OLD	PD 0778	Calabasas	Calabasas	45”	Round	34.14422	-118.63045
Compton Creek	CC_SW_LAN	BI 0073 – U1 Line C	City of LA	City of LA, County of LA	108”	Rectangular	33.93540	-118.25479
Rio Hondo	RH_SW_LER	BI 1213 - Line A	South El Monte	South El Monte	45”	Rectangular	34.04209	-118.05170
Rio Hondo	RH_SW_ROB	Rubio Drain	San Marino	County of LA, Pasadena, San Marino	234”	Rectangular	34.12867	-118.10036
Arroyo Seco	AS_SW_SEC	Seco St Drain	Pasadena	Pasadena, County of LA	81”	Rectangular	34.15511	-118.16757
Verdugo Wash	VW_SW_CAN	BI 0434 Northeast Glendale	Glendale	County of LA, Glendale, La Cañada Flintridge	126”	Rectangular	34.18991	-118.22734
Burbank Western Channel	BWC_SW_MAI	BI 0169	Burbank	Burbank	72”	Rectangular	34.16096	-118.30999
Tujunga Wash	TW_SW_BUR	BI 0091 (F1046)	City of LA	City of LA	81”	Round	34.17019	-118.41335

Table 20. Land Use Summary (Percent of Drainage Area)

Subwatershed and Site	Percent of Jurisdiction ⁽¹⁾			
	Res	Com/Ind	Ag/Nur	Open
LA River Reach 2	54%	40%	<1%	6%
LAR_02_SW_MAI	70%	25%	<1%	5%
BI 0067 -U2 Line A Site (Alternate)	74%	20%	<1%	7%
LA River Reach 3	64%	26%	<1%	10%
LAR_03_SW_COL	69%	23%	1%	7%
BI 0060 - A & B (Alternate)	37%	61%	<1%	1%
LA River Reach 4	70%	25%	1%	4%
LAR_04_SW_BUE	76%	24%	<1%	<1%
BI 5217 (Alternate)	89%	11%	<1%	<1%
LA River Reaches 5 and 6⁽²⁾	69%	25%	2%	4%
LAR_06_SW_WIN	67%	31%	<1%	2%
BI 0472 (Alternate)	88%	11%	<1%	1%
LA River Reach 6⁽³⁾	79%	13%	1%	7%
LAR_06_SW_OLD	99%	1%	<1%	<1%
LA City Drain (Alternate)	98%	<1%	2%	<1%
Compton Creek	68%	30%	<1%	2%
CC_SW_LAN	63%	35%	<1%	1%
BI 0073 – U2 Line A (Alternate)	65%	33%	<1%	2%
Rio Hondo⁽⁴⁾	33%	63%	1%	3%
RH_SW_LER	38%	56%	3%	2%
BI 0529 – Line B (Alternate)	58%	40%	<1%	2%
Rio Hondo⁽⁵⁾	68%	23%	1%	8%
RH_SW_ROB	82%	16%	<1%	2%
BI 1225 - Unit 2 (Alternate)	40%	43%	5%	12%
Arroyo Seco	79%	12%	<1%	9%
AS_SW_SEC	69%	25%	<1%	6%
BI 0560 (Alternate)	69%	22%	<1%	10%
Verdugo Wash	84%	12%	<1%	4%
VW_SW_CAN	69%	29%	<1%	2%
BI 3602 U01 (Alternate)	77%	17%	<1%	6%
Burbank Western Channel	61%	34%	1%	4%
BWC_SW_MAI	71%	28%	<1%	1%
BI 0172 (Alternate)	54%	20%	<1%	26%
Tujunga Wash	70%	23%	2%	5%
TW_SW_BUR	86%	14%	<1%	<1%
BI 0107 (Alternate)	82%	17%	1%	<1%

1. Land use classifications include: residential (Res), commercial and industrial (Com/Ind), agriculture and nursery (Ag/Nur), and open space (Open). Totals correspond to the percent of the total area considered in the EWMP (i.e., only using open space characterized as golf courses, local parks, and regional parks).
2. Areas of subwatersheds within the jurisdiction of the Cities of Calabasas and Los Angeles and County of Los Angeles.
3. Area of subwatershed within the jurisdiction of the Cities of Calabasas and Hidden Hills.
4. Area of subwatershed within the jurisdiction of the City of South El Monte.
5. Area of subwatershed excluding the area within the City of South El Monte.

Table 21. ULARWMAG Member Represented by Each Stormwater Outfall Monitoring Site⁽¹⁾

Jurisdiction	Site	LA River					Tributaries ⁽²⁾											Lakes ⁽³⁾		
		2	3	4	5	6	TW	BWC	VW	AS	RH	CC	BuC	ACW	MC	DC	BeC	LEG	EP	CAL
Alhambra	LAR_02_SW_MAI	D																		
	RH_SW_ROB									D										
Burbank	LAR_03_SW_COL	I	D																	
	LAR_04_SW_BUE	I	I	D																
	BWC_SW_MAI	I	I							D										
Calabasas	LAR_06_SW_WIN	I	I	I	I	I									D	D				D
	LAR_06_SW_OLD	I	I	I	I	I									D	D				D
City of Los Angeles	LAR_02_SW_MAI	D																	D	
	LAR_03_SW_COL	I	D																	
	LAR_04_SW_BUE	I	I	D																
	LAR_06_SW_WIN	I	I	I	D	D						D	D	D	D	D				
	CC_SW_LAN										D									
	AS_SW_SEC	I								D										
	VW_SW_CAN	I	I							D										
	BWC_SW_MAI	I	I							D										
County of Los Angeles	TW_SW_BUR	I	I	I			D													
	LAR_02_SW_MAI	D																		
	LAR_04_SW_BUE	I	I	D																
	LAR_06_SW_WIN	I	I	I	D	D						D	D	D	D	D				
	CC_SW_LAN										D									
	RH_SW_LER																	D		
	RH_SW_ROB									D										
	AS_SW_SEC	I								D										
County of Los Angeles	VW_SW_CAN	I	I							D										
	TW_SW_BUR	I	I	I			D													

Jurisdiction	Site	LA River					Tributaries ⁽²⁾											Lakes ⁽³⁾		
		2	3	4	5	6	TW	BWC	VW	AS	RH	CC	BuC	ACW	MC	DC	BeC	LEG	EP	CAL
Glendale	LAR_03_SW_COL	I	D																	
	VW_SW_CAN	I	I							D										
	BWC_SW_MAI	I	I							D										
Hidden Hills	LAR_06_SW_OLD	I	I	I	I	I									D		D			
La Cañada Flintridge	LAR_03_SW_COL	I	D																	
	VW_SW_CAN	I	I							D										
	AS_SW_SEC	I								D										
Montebello	RH_SW_ROB										D									
Monterey Park	LAR_02_SW_MAI	D																		
	RH_SW_ROB										D									
Pasadena	LAR_02_SW_MAI	D																		
	LAR_03_SW_COL	I	D																	
	RH_SW_ROB										D									
	AS_SW_SEC	I									D									
	VW_SW_CAN	I	I								D									
Rosemead	RH_SW_ROB										D									
San Fernando	TW_SW_BUR	I	I	I			D													
San Gabriel	RH_SW_ROB										D									
San Marino	RH_SW_ROB										D									
South El Monte	RH_SW_LER										D							D		
South Pasadena	LAR_02_SW_MAI	D																		
	RH_SW_ROB										D									
	AS_SW_SEC	I									D									
Temple City	RH_SW_ROB										D									

D = Jurisdiction discharges directly; I = Jurisdiction discharges indirectly (i.e., upstream)

1. If an exceedance is observed in a waterbody, the paired data collected from the drains discharging directly and/or indirectly to the waterbody will be used to assess whether the ULARWMAG member caused or contributed to the exceedance.

2. TW(Tujunga Wash), BWC (Burbank Western Channel), VW (Verdugo Wash), AS (Arroyo Seco), RH (Rio Hondo), CC (Compton Creek), BuC (Bull Creek), ACW (Aliso Canyon Wash), MC (McCoy Canyon Creek), DC (Dry Canyon Creek), and BeC (Bell Creek)
3. LEG (Legg Lake), EP (Echo Park Lake), CAL (Lake Calabasas)

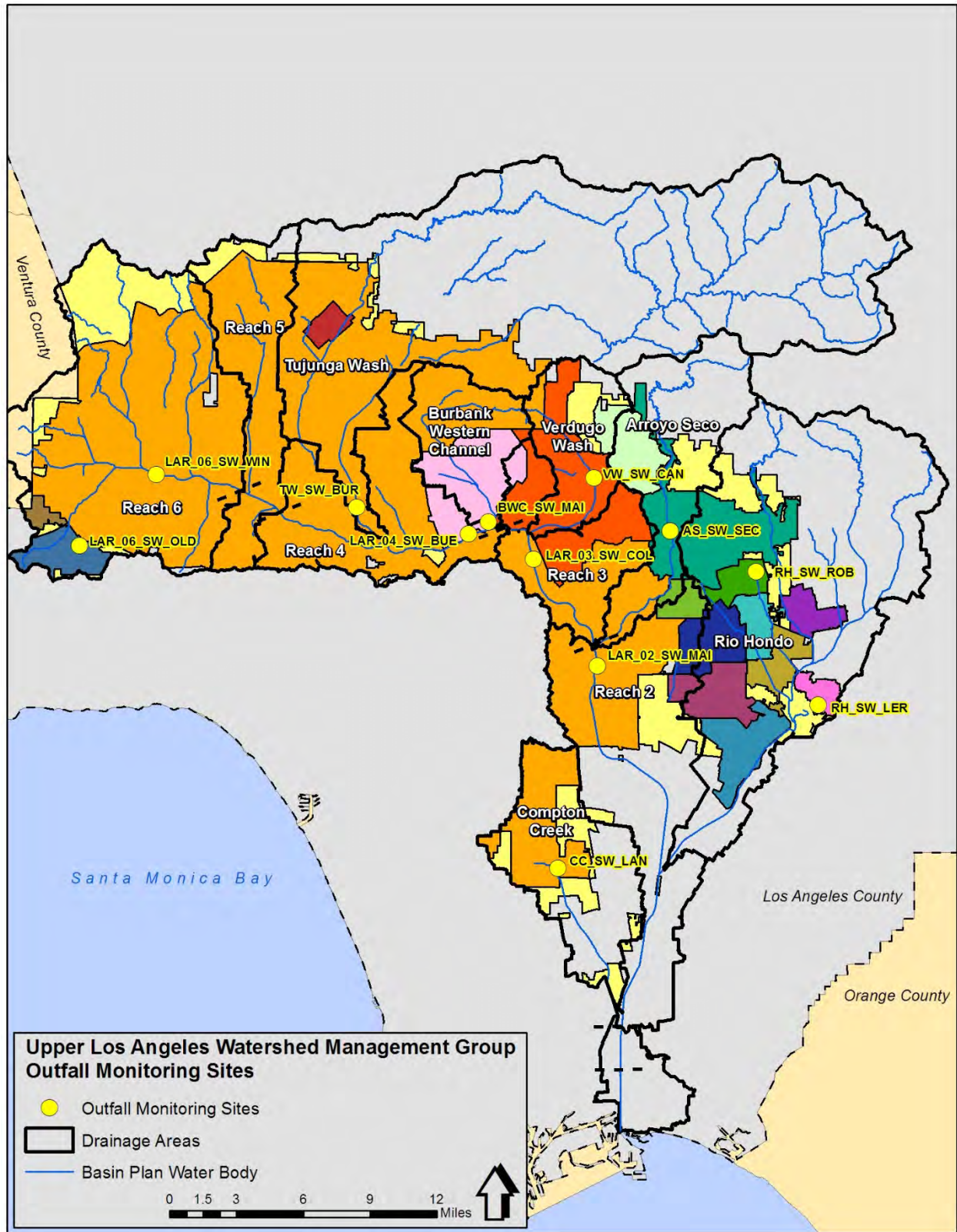

Figure 9. Overview of Stormwater Outfall Monitoring Sites

7.2 Analysis of Representative Outfall Approach

The following presents an analysis evaluating whether a representative outfall approach will provide sufficient information to implement this CIMP consistent with the MRP. Specifically, the analysis evaluates variability of stormwater outfall data in the context of the ability to distinguish between sites and whether more sites are necessary to adequately characterize wet weather urban runoff for the purposes of determining the quality of discharges, compliance with applicable WQBELs, and whether discharges are causing or contributing to exceedances of RWLs.

The inter-event variability (e.g., for different storm events) in stormwater discharge quality is much greater than between individual outfall drainages or major land uses. Based on stormwater monitoring results from other programs in California, discharge quality from drainages with similar mixed land uses is not substantially different, and it will be impossible to distinguish statistically between drainages with a reasonable amount of monitoring because of the high variability in discharge water quality for each site. The statistical power analysis based on the range of typical stormwater discharge water quality distributions and the number of samples collected over the time frame of the Permit, 15 samples per site, is enumerated in **Table 22**. For example, the results of the analysis indicate that an average difference between sites would need to be greater than 62% to be detected with 95% confidence and 80% power for a pollutant with a fairly “typical” coefficient of variance (COV) of 0.66. COVs for stormwater discharge quality are generally greater than 0.2 and commonly exceed 1.0. Programmatically meaningful differences (i.e., differences between sites as small as 20%) would not be expected to be detected for most constituents over the time frame of the Permit.

Given the high variability typical of stormwater pollutant levels, and with only a few storm events that can be collected per year given climatic conditions, it will not be possible to make meaningful distinctions between drainages, either within land use types, across land use types, or between jurisdictions. Management implementation by individual Permittees is also expected to be relatively consistent throughout the ULAR watershed given the implementation of a EWMP, so additional focus on geographic differences is not necessary. This means that only a handful of sites are needed to adequately characterize land use discharge water quality within the ULARWMAG EWMP area. Consequently, sampling more than a few representative sites is unlikely to significantly improve characterization of runoff quality, or to better inform the ULARWMAG’s management decisions.

Realistically achievable changes in stormwater runoff quality or loads (e.g., 20–50% reductions) are statistically demonstrable only over relatively long periods of time (≥ 10 years). This is also due to the high variability between events and the relatively few number of events that can be sampled each season. Additional monitoring sites will do little to improve the statistical power of such trend analysis within the permit time frame compared to longer periods of evaluation. This also supports the need to assess management effectiveness and compliance based primarily on successful implementation actions rather than explicit demonstration of improvements in runoff quality.

Based on the evaluations above, the ULARWMAG’s CIMP approach to monitor approximately one outfall for each major waterbody in the EWMP area will provide the representative data

needed to meet the specific Permit objectives for stormwater outfall monitoring and support management decisions of the ULARWMAG. Additional monitoring sites will not provide significant improvements in representation or characterization of discharge quality, or additional information for discharge quality management.

Table 22. Detectible Significant Percent Differences between Sites

Sample Size = 15, alpha = 0.05		
COV	power=0.8	power 0.9
0.20	21%	24%
0.31	32%	36%
0.42	42%	48%
0.53	52%	59%
0.66	62%	70%
0.80	71%	81%
0.95	80%	91%
1.12	89%	100%
1.31	97%	109%

7.3 Stormwater Outfall Site Fact Sheets

Fact sheets for the 12 storm water outfall monitoring sites are presented. Additionally, alternative sites are identified for each of the proposed sites.

7.3.1 Los Angeles River Reach 2 Subwatershed Site - LAR_02_SW_MAI

Water Body	Location	Drain Name	Size	Site Type	Latitude	Longitude
LAR Reach 2	City of LA	BI 0062 – Line A	147"	SW Outfall	34.06720	-118.22424

General Description: Box outfall discharging just downstream of N Main St.



LAR_02_SW_MAI Aerial View



LAR_02_SW_MAI

7.3.2 Los Angeles River Reach 2 Subwatershed Alternate Site

Water Body	Jurisdiction	Drain Name	Size	Shape	Material	Latitude	Longitude
LAR Reach 2	City of LA	BI 0067 - U2 Line A	138"	Rectangular	Reinforced Concrete Box	34.03410	-118.22666



7.3.3 Los Angeles River Reach 3 Subwatershed Site - LAR_03_SW_COL

Water Body	Location	Drain Name	Size	Site Type	Latitude	Longitude
LAR Reach 3	City of LA	BI 9506 U01	144"	SW Outfall	34.13668	-118.27477

General Description: Double box outfall discharging between Colorado St and Los Feliz Blvd and just downstream of a Los Angeles-Glendale Water Reclamation Plant discharge point. Sample will be taken from manhole located on adjacent City of Los Angeles Yard located at 34.137044, -118.271779.



LAR_03_SW_COL Aerial View



LAR_03_SW_COL

7.3.4 Los Angeles River Reach 3 Subwatershed Alternate Site

Water Body	Jurisdiction	Drain Name	Size	Shape	Material	Latitude	Longitude
LAR Reach 3	City of LA	BI 0060 - A & B	144"	Round	Reinforced Concrete Pipe	34.12051	-118.26923



7.3.5 Los Angeles River Reach 4 Subwatershed Site - LAR_04_SW_BUE

Water Body	Location	Drain Name	Size	Site Type	Latitude	Longitude
LAR Reach 4	Burbank	BI 0168 - Frederick St Drain	72 inches	SW Outfall	34.15319	-118.32545

General Description: Outfall discharging to LAR Reach 4 upstream of Highway 134.



LAR_04_SW_BUE Aerial View



LAR_04_SW_BUE

7.3.6 Los Angeles River Reach 4 Subwatershed Alternate Site

Water Body	Jurisdiction	Drain Name	Size	Shape	Material	Latitude	Longitude
LAR Reach 4	City of LA	BI 5217	144"	Rectangular	Reinforced Concrete Box	34.15892	-118.45717



7.3.7 Los Angeles River Reach 6 (City of Los Angeles and County of Los Angeles) Subwatershed Site - LAR_06_SW_WIN

Water Body	Location	Drain Name	Size	Site Type	Latitude	Longitude
LAR Reach 6	City of LA	BI 0477	108 inches	SW Outfall	34.19097	-118.57072

General Description: Box outfall discharging just downstream of Winnetka Ave.



LAR_06_SW_WIN Aerial View



LAR_06_SW_WIN

7.3.8 Los Angeles River Reach 6 (City of Los Angeles and County of Los Angeles) Subwatershed Alternate Site

Water Body	Jurisdiction	Drain Name	Size	Shape	Material	Latitude	Longitude
LAR Reach 6	City of LA	BI 0472	114"	Rectangular	Reinforced Concrete Box	34.18397	-118.51044



**7.3.9 Los Angeles River Reach 6 (Cities of Calabasas and Hidden Hills)
Subwatershed Site - LAR_06_SW_OLD**

Water Body	Location	Drain Name	Size	Site Type	Latitude	Longitude
Reach 6	Calabasas	PD 0778	45 inches	SW Outfall	34.14422	-118.63045

General Description: Round outfall discharging just west of the intersection of Old Topanga Canyon Rd and Wrencrest Dr.



LAR_06_SW_OLD Aerial View



LAR_06_SW_OLD

7.3.10 Los Angeles River Reach 6 (Cities of Calabasas and Hidden Hills) Subwatershed Alternate Site

Water Body	Jurisdiction	Drain Name	Size	Shape	Material	Latitude	Longitude
Reach 6	City of LA	LA City Drain	78"	Round	Reinforced Concrete Pipe	34.18253	-118.65229

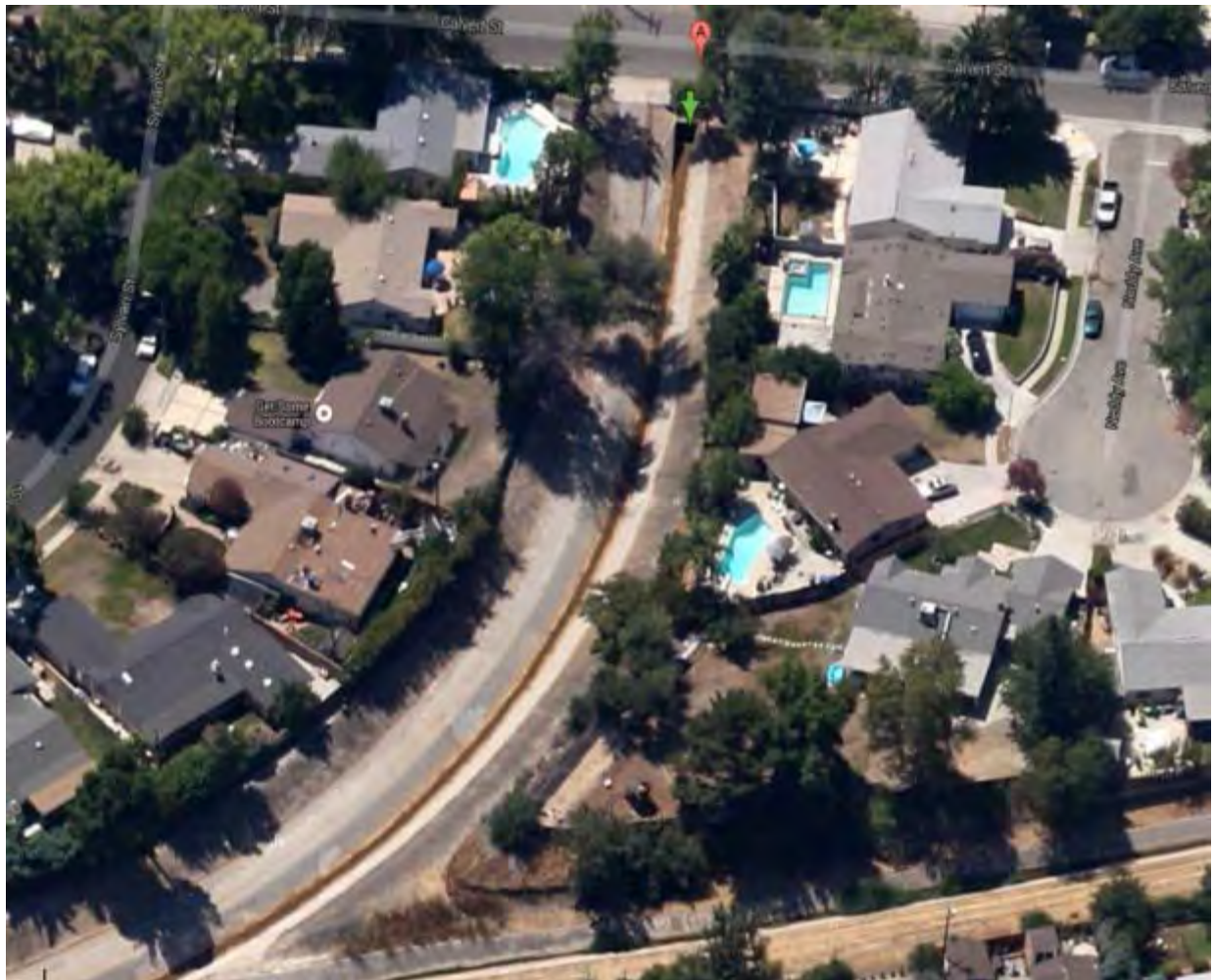

7.3.11 Compton Creek Subwatershed Site - CC_SW_LAN

Water Body	Location	Drain Name	Size	Site Type	Latitude	Longitude
Compton Creek	City of LA	BI 0073 – U1 Line C	108 inches	SW Outfall	33.93540	-118.25479

General Description: Box outfall discharging just upstream of E Lanzit Ave.



CC_SW_LAN Aerial View



CC_SW_LAN

7.3.12 Compton Creek Subwatershed Alternate Site

Water Body	Jurisdiction	Drain Name	Size	Shape	Material	Latitude	Longitude
Compton Creek	City of LA	BI 0073 – U2 Line A	108"	Double Box	Reinforced Concrete Box	33.93818	-118.26477



7.3.13 Rio Hondo (City of South El Monte) Subwatershed Site - RH_SW_LER

Water Body	Location	Drain Name	Size	Site Type	Latitude	Longitude
Legg Lake System	South El Monte	BI 1213 - Line A	45 inches	SW Outfall	34.04209	-118.05170

General Description: Manhole located in parkway adjacent to Lerma Rd near the intersection with Fawcett Ave.



RH_SW_LER Aerial View

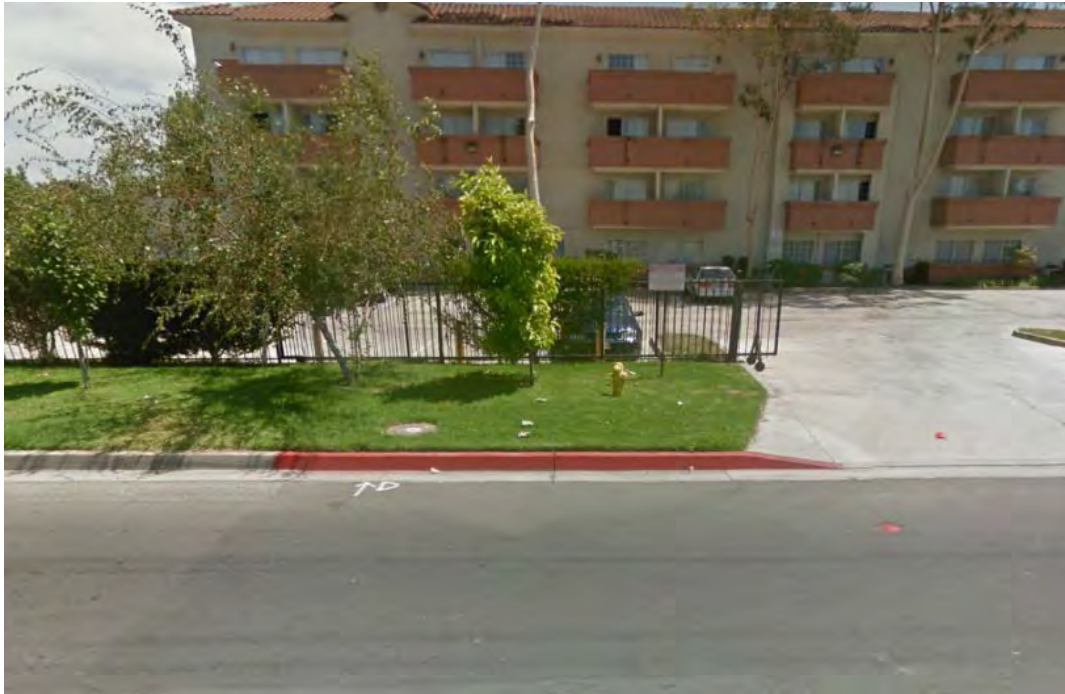

RH_SW_LER

7.3.14 Rio Hondo (City of South El Monte) Subwatershed Alternate Site

Water Body	Jurisdiction	Drain Name	Size	Shape	Material	Latitude	Longitude
Legg Lake System	County of Los Angeles	BI 0529 – Line B	90"	Rectangular	Reinforced Concrete Pipe	34.03760	-118.05575



7.3.15 Rio Hondo (Excluding South El Monte) Subwatershed Site - RH_SW_ROB

Water Body	Location	Drain Name	Size	Site Type	Latitude	Longitude
Rubio Wash	San Marino	Rubio Drain	234 inches	SW Outfall	34.12867	-118.10036

General Description: Outfall discharging at the point where Rubio Wash daylights near Robles Ave.



RH_SW_ROB Aerial View



RH_SW_ROB

7.3.16 Rio Hondo (Excluding South El Monte) Subwatershed Alternate Site

Water Body	Jurisdiction	Drain Name	Size	Shape	Material	Latitude	Longitude
Rio Hondo	County of Los Angeles	BI 1225 - Unit 2	120"	Rectangular	Reinforced Concrete Box	34.03166	-118.07166



7.3.17 Arroyo Seco Subwatershed Site - AS_SW_SEC

Water Body	Location	Drain Name	Size	Site Type	Latitude	Longitude
Arroyo Seco	Pasadena	Seco St Drain	81 inches	SW Outfall	34.15511	-118.16757

General Description: Box outfall discharging downstream of Seco St.



AS_SW_SEC Aerial View

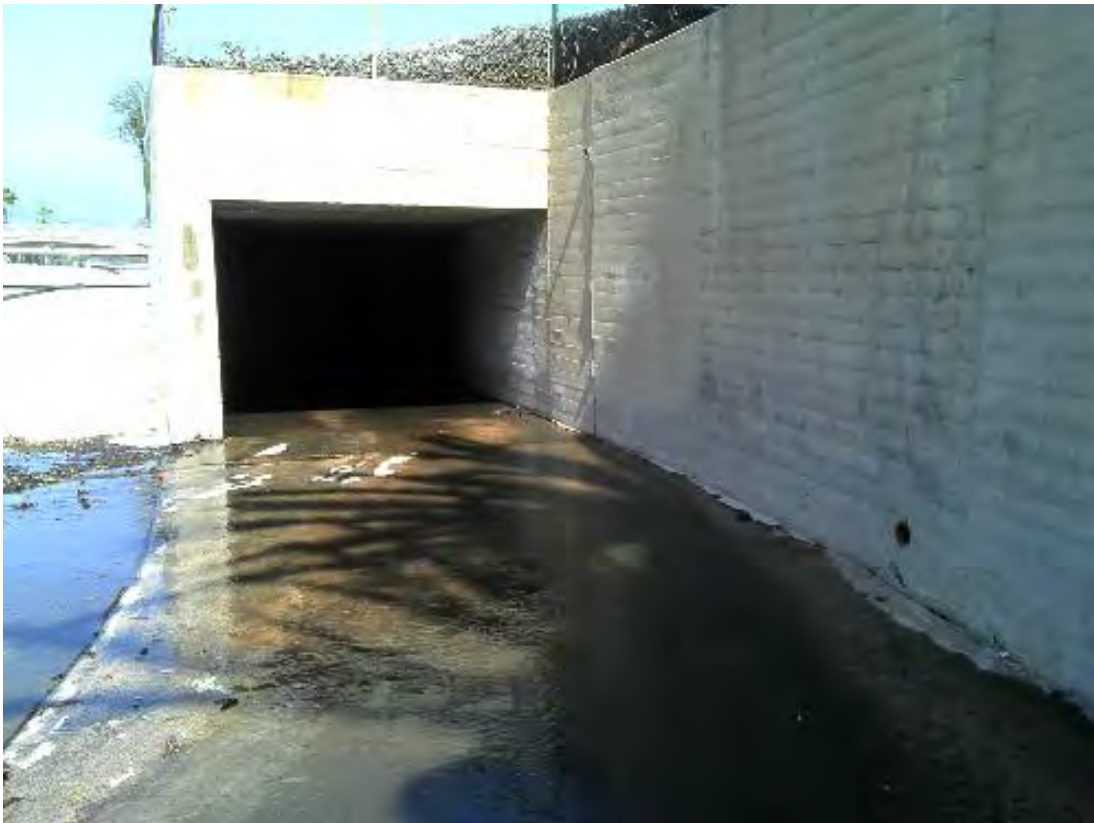

AS_SW_SEC

7.3.18 Arroyo Seco Subwatershed Alternate Site

Water Body	Jurisdiction	Drain Name	Size	Shape	Material	Latitude	Longitude
Arroyo Seco	Pasadena	BI 0560	72"	Round	Reinforced Concrete Pipe	34.17800	-118.17184



7.3.19 Verdugo Wash Subwatershed Site - VW_SW_CAN

Water Body	Location	Drain Name	Size	Site Type	Latitude	Longitude
Verdugo Wash	Glendale	BI 0434 Northeast Glendale	126 inches	SW Outfall	34.18991	-118.22734

General Description: Box outfall discharging near N Verdugo Rd downstream of Cañada Blvd.



VW_SW_CAN Aerial View



VW_SW_CAN

7.3.20 Verdugo Wash Subwatershed Alternate Site

Water Body	Jurisdiction	Drain Name	Size	Shape	Material	Latitude	Longitude
Verdugo Wash	Glendale	BI 3602 U01	60"	Round	Reinforced Concrete Pipe	34.23547	-118.2550



7.3.21 Burbank Western Channel Subwatershed Site - BWC_SW_MAI

Water Body	Location	Drain Name	Size	Site Type	Latitude	Longitude
Burbank Western Channel	Burbank	BI 0169	72 inches	SW Outfall	34.16096	-118.30999

General Description: Box outfall discharging southeast of the intersection of Riverside Dr and S Main St.



BWC_SW_MAI Aerial View



BWC_SW_MAI

7.3.22 Burbank Western Channel Subwatershed Alternate Site

Water Body	Jurisdiction	Drain Name	Size	Shape	Material	Latitude	Longitude
Burbank Western Channel	Burbank	BI 0172	66"	Round	Reinforced Concrete Pipe	34.17973	-118.31493



7.3.23 Tujunga Wash Subwatershed Site - TW_SW_BUR

Water Body	Location	Drain Name	Size	Site Type	Latitude	Longitude
Tujunga Wash	City of LA	BI 0091 (F1046)	81 inches	SW Outfall	34.17019	-118.41335

General Description: Round outfall discharging between Burbank Blvd and Chandler Blvd.

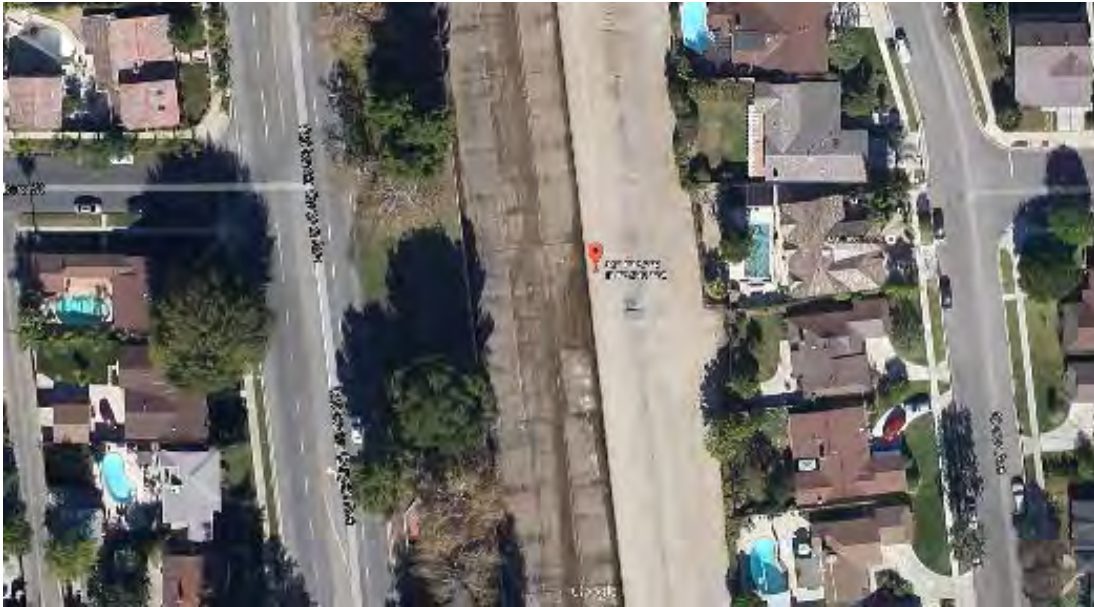

TW_SW_BUR Aerial View



TW_SW_BUR

7.3.24 Tujunga Wash Alternate Site - BI 0107

Water Body	Jurisdiction	Drain Name	Size	Shape	Material	Latitude	Longitude
Tujunga Wash	City of LA	BI 0107	78"	Round	Reinforced Concrete Pipe	34.21964	-118.42334



8 Monitoring Location References

County of Los Angeles Department of Public Works, City of Los Angeles WPD, and City of Calabasas. 2005. *Monitoring Work Plan to Assess Nutrients Loading from the Municipal Separate Storm Sewer System in Los Angeles River Watershed*. March 2005.

Los Angeles River Metals TMDL Technical Committee. 2008. *Los Angeles River Metals TMDL Coordinated Monitoring Plan*. Chaired by the City and County of Los Angeles. March 25, 2008.

Los Angeles River Watershed Bacteria TMDL Technical Committee. 2013. *Coordinated Monitoring Plan for Los Angeles River Watershed Bacteria TMDL – Compliance Monitoring*. Chaired by the City of Los Angeles. March 23, 2013.

Attachment C. Analytical and Monitoring Procedures

Attachment C details the monitoring procedures that will be utilized to collect and analyze samples to meet the goals and objectives of the CIMP and the Permit. The details contained herein serve as a guide for ensuring that consistent protocols and procedures are in place for successful sample collection and analysis. The attachment is divided into the following sections:

1. Analytical Procedures
2. Sampling Methods and Sample Handling
3. Quality Assurance/Quality Control
4. Instrument/Equipment Calibration and Frequency
5. Monitoring Procedures References

9 Analytical Procedures

The following subsections detail the analytical procedures for data generated in the field and in the laboratory.

9.1 Field Parameters

Portable field meters will measure field parameters within specifications outlined in **Table 23**.

Table 23. Analytical Methods and Project Reporting Limits for Field Parameters

Parameter	Method	Range	Project RL
Current velocity	Electromagnetic	-0.5 to +20 ft/s	0.05 ft/s
pH	Electrometric	0 – 14 pH units	NA
Temperature	High stability thermistor	-5 – 50 °C	NA
Dissolved oxygen	Membrane or Optical	0 – 50 mg/L	0.5 mg/L
Turbidity	Nephelometric	0 – 3000 NTU	0.2 NTU
Conductivity	Graphite electrodes	0 – 10 mmhos/cm	2.5 umhos/cm

RL – Reporting Limit NA – Not applicable

9.2 Analytical Methods and Method Detection and Reporting Limits

Method detection limits (MDL) and reporting limits (RLs) must be distinguished for proper understanding and data use. The MDL is the minimum analyte concentration that can be measured and reported with a 99% confidence that the concentration is greater than zero. The RL represents the concentration of an analyte that can be routinely measured in the sampled matrix within stated limits and with confidence in both identification and quantitation. For this CIMP, the term RL is equivalent to the term “Minimum Levels” presented in Table E-2 of the MRP (pages E-17 through E-20).

For this CIMP, RLs must be verifiable by having the lowest non-zero calibration standard or calibration check sample concentration at or less than the RL. RLs have been established in this CIMP based on the verifiable levels and general measurement capabilities demonstrated for each

method. These RLs should be considered as maximum allowable RLs to be used for laboratory data reporting. Note that samples diluted for analysis may have sample-specific RLs that exceed these RLs. This will be unavoidable on occasion. However, if samples are consistently diluted to overcome matrix interferences, the analytical laboratory will be required to notify the ULARWMG regarding how the sample preparation or test procedure in question will be modified to reduce matrix interferences so that project RLs can be met consistently.

Analytical methods and RLs required for samples analyzed in the laboratory are summarized in **Table 24**, **Table 25**, and **Table 26** for analysis in water, sediment, and tissue, respectively. For organic constituents, environmentally relevant detection limits will be used to the extent practicable. The RLs listed in **Table 24** are consistent with the requirements of the available minimum levels provided in the MRP, except for total dissolved solids, which was set equal to the minimum level identified in the California State Water Resources Control Board’s Surface Water Ambient Monitoring Program’s (SWAMP) Quality Assurance Project Plan. Alternative methods with RLs that are at or below those presented in **Table 24**, **Table 25**, and **Table 26** are considered equivalent and can be used in place of the methods presented in **Table 24**, **Table 25**, and **Table 26**.

Prior to the analysis of any environmental samples, the laboratory must have demonstrated the ability to meet the minimum performance requirements for each analytical method presented in **Table 24**, **Table 25**, and **Table 26**. The initial demonstration of capability includes the ability to meet the project RLs, the ability to generate acceptable precision and accuracy, and other analytical and quality control parameters documented in this CIMP. Data quality objectives for precision and accuracy are summarized in **Table 27**.

Table 24. Analytical Methods, Project Reporting Limits (RLs), and MRP Table E-2 Minimum Levels (MLs) for Laboratory Analysis of Water Samples

Parameter/Constituent	Method ⁽¹⁾	Units	Project RL	MRP Table E-2 ML
Toxicity				
<i>Pimephales promelas</i>	EPA-821-R-02-013 (1000.0) and EPA-821-R-02-012 (2000.0)	NA	NA	NA
<i>Ceriodaphnia dubia</i>	EPA-821-R-02-013 (1002.0) and EPA-821-R-02-012 (2002.0)	NA	NA	NA
<i>Selenastrum capricornutum</i>	EPA-821-R-02-013 (1003.0)	NA	NA	NA
Bacteria				
<i>Escherichia coli</i>	SM 9221/SM 9223 B	MPN/100mL	10	235
Conventionals				
Oil and Grease	EPA 1664A	mg/L	5	5
Cyanide	EPA 335.4/SM 4500-CN E	mg/L	0.005	0.005
pH	SM 4500 H+B/ EPA 9040/ EPA 9045D	NA	NA	0-14

Parameter/Constituent	Method ⁽¹⁾	Units	Project RL	MRP Table E-2 ML
Dissolved Oxygen	NA	mg/L	0.5	Sensitivity to 5 mg/L
Specific Conductance	EPA 120.1	µs/cm	1	1
Turbidity	SM 2130B/EPA 180.1	NTU	0.1	0.1
Total Hardness	SM 2340C	mg/L	2	2
Dissolved Organic Carbon	SM 5310B	mg/L	0.6	NA
Total Organic Carbon	SM 5310B	mg/L	1	1
Total Petroleum Hydrocarbon	EPA 1664	mg/L	5	5
Biochemical Oxygen Demand	SM-5210B	mg/L	5	2
Chemical Oxygen Demand	SM 5220D	mg/L	20	20-900
MBAS	SM 5540C	mg/L	0.5	0.5
Chloride	EPA 300.0	mg/L	1	2
Fluoride	EPA 300.0	mg/L	0.1	0.1
Sulfate	EPA 300.0/EPA 375.4	mg/L	1	NA
Perchlorate	EPA 314.0	µg/L	4	4
Chlorophyll a	SM 10200 H	mg/L	0.01	NA
Dissolved Phosphorus (as P)	SM 4500-P E	mg/L	0.05	0.05
Total Phosphorus (as P)	SM 4500-P E	mg/L	0.05	0.05
Orthophosphate (as P)	SM 4500-PE/EPA 300.0	mg/L	0.2	NA
Ammonia (as N)	SM 4500-NH3 C	mg/L	0.1	0.1
Nitrate + Nitrite (as N)	EPA 300.0	mg/L	0.1	0.1
Nitrate (as N)	EPA 300.0	mg/L	0.1	0.1
Nitrite (as N)	EPA 300.0	mg/L	0.1	0.1
Total Kjeldahl Nitrogen (TKN)	SM 4500-NH3 C	mg/L	0.1	0.1
Total Alkalinity	SM 2320B	mg/L	2	2
Solids				
Suspended Sediment Concentration (SSC)	ASTMD 3977-97	mg/L	3	NA
Total Suspended Solids (TSS)	SM 2540D	mg/L	2	2
Total Dissolved Solids (TDS)	SM 2540C	mg/L	10	2
Volatile Suspended Solids	EPA 1684	mg/L	1	2
Metals in Freshwater (dissolved and total)				
Aluminum	EPA 200.8	µg/L	100	100
Antimony	EPA 200.8	µg/L	0.5	0.5
Arsenic	EPA 200.8	µg/L	1	1
Beryllium	EPA 200.8	µg/L	0.5	0.5
Cadmium	EPA 200.8	µg/L	0.25	0.25

Parameter/Constituent	Method ⁽¹⁾	Units	Project RL	MRP Table E-2 ML
Chromium (total)	EPA 200.8	µg/L	0.5	0.5
Chromium (Hexavalent)	EPA 218.6	µg/L	5	5
Copper	EPA 200.8	µg/L	0.5	0.5
Iron	EPA 200.8	µg/L	100	100
Lead	EPA 200.8	µg/L	0.5	0.5
Mercury	EPA 1631	µg/L	0.5	0.5
Nickel	EPA 200.8	µg/L	1	1
Selenium	EPA 200.8	µg/L	1	1
Silver	EPA 200.8	µg/L	0.25	0.25
Thallium	EPA 200.8	µg/L	1	1
Zinc	EPA 200.8	µg/L	1	1
Organochlorine Pesticides				
Aldrin	EPA 608	ng/L	5	5
alpha-BHC	EPA 608	ng/L	10	10
beta-BHC	EPA 608	ng/L	5	5
delta-BHC	EPA 608	ng/L	5	5
gamma-BHC (Lindane)	EPA 608	ng/L	20	20
Chlordane-alpha	EPA 608	ng/L	100	100
Chlordane-gamma	EPA 608	ng/L	100	100
Oxychlordane	EPA 608	ng/L	200	NA
Cis-nonachlor	EPA 608	ng/L	200	NA
Trans-nonachlor	EPA 608	ng/L	200	NA
2,4'-DDD	EPA 8270C/EPA 625	ng/L	2	NA
2,4'-DDE	EPA 8270C/EPA 625	ng/L	2	NA
2,4'-DDT	EPA 8270C/EPA 625	ng/L	2	NA
4,4'-DDD	EPA 8270C/EPA 625	ng/L	50	50
4,4'-DDE	EPA 8270C/EPA 625	ng/L	50	50
4,4'-DDT	EPA 8270C/EPA 625	ng/L	10	10
Dieldrin	EPA 608	ng/L	10	10
Endosulfan I	EPA 608	ng/L	20	20
Endosulfan II	EPA 608	ng/L	10	10
Endosulfan Sulfate	EPA 608	ng/L	50	50
Endrin	EPA 608	ng/L	10	10
Endrin Aldehyde	EPA 608	ng/L	10	10
Heptachlor	EPA 608	ng/L	10	10
Heptachlor Epoxide	EPA 608	ng/L	10	10
Toxaphene	EPA 608	ng/L	500	500

Parameter/Constituent	Method ⁽¹⁾	Units	Project RL	MRP Table E-2 ML
PCBs				
Congeners ⁽²⁾	EPA 8270C/EPA 625	ng/L	2	NA
Aroclors (1016, 1221, 1232, 1242, 1248, 1254, 1260)	EPA 8270C/EPA 625/EPA 608	ng/L	500	500
Organophosphorus Pesticides				
Chlorpyrifos	EPA 614	ng/L	50	50
Diazinon	EPA 614	ng/L	10	10
Malathion	EPA 614	ng/L	1000	1000
Triazine				
Atrazine	EPA 530	µg/L	2	2
Cyanazine	EPA 530	µg/L	2	2
Prometryn	EPA 530	µg/L	2	2
Simazine	EPA 530	µg/L	2	2
Dioxins				
2,3,7,8-TCDD	EPA 1613	ng/L	0.005	NA
1,2,3,7,8-PeCDD	EPA 1613	ng/L	0.025	NA
1,2,3,7,8-PeCDF	EPA 1613	ng/L	0.025	NA
2,3,4,7,8-PeCDF	EPA 1613	ng/L	0.025	NA
1,2,3,4,7,8-HxCDD	EPA 1613	ng/L	0.025	NA
1,2,3,6,7,8-HxCDD	EPA 1613	ng/L	0.025	NA
1,2,3,7,8,9-HxCDD	EPA 1613	ng/L	0.025	NA
1,2,3,4,7,8-HxCDF	EPA 1613	ng/L	0.025	NA
1,2,3,6,7,8-HxCDF	EPA 1613	ng/L	0.025	NA
1,2,3,7,8,9-HxCDF	EPA 1613	ng/L	0.025	NA
2,3,4,6,7,8-HxCDF	EPA 1613	ng/L	0.025	NA
1,2,3,4,6,7,8-HpCDD	EPA 1613	ng/L	0.025	NA
1,2,3,4,6,7,8-HpCDF	EPA 1613	ng/L	0.025	NA
1,2,3,4,7,8,9-HpCDF	EPA 1613	ng/L	0.025	NA
OCDD	EPA 1613	ng/L	0.025	NA
OCDF	EPA 1613	ng/L	0.050	NA
Herbicides				
2,4-D	EPA 8151A	µg/L	10	10
Glyphosate	EPA 547	µg/L	5	5
2,4,5-TP-SILVEX	EPA 8151A	µg/L	0.5	0.5
Semivolatile Organic Compounds (SVOCs)				
1,2-Diphenylhydrazine	EPA 625	µg/L	1	1

Parameter/Constituent	Method ⁽¹⁾	Units	Project RL	MRP Table E-2 ML
2,4,6-Trichlorophenol	EPA 625	µg/L	10	10
2,4-Dichlorophenol	EPA 625	µg/L	1	1
2,4-Dimethylphenol	EPA 625	µg/L	2	2
2,4-Dinitrophenol	EPA 625	µg/L	5	5
2,4-Dinitrotoluene	EPA 625	µg/L	5	5
2,6-Dinitrotoluene	EPA 625	µg/L	5	5
2-Chloronaphthalene	EPA 625	µg/L	10	10
2-Chlorophenol	EPA 625	µg/L	2	2
2-Methyl-4,6-dinitrophenol	EPA 625	µg/L	5	5
2-Nitrophenol	EPA 625	µg/L	10	10
3,3'-Dichlorobenzidine	EPA 625	µg/L	5	5
4-Bromophenyl phenyl ether	EPA 625	µg/L	5	5
4-Chloro-3-methylphenol	EPA 625	µg/L	1	1
4-Chlorophenyl phenyl ether	EPA 625	µg/L	5	5
4-Nitrophenol	EPA 625	µg/L	5	5
Acenaphthene	EPA 625	µg/L	1	1
Acenaphthylene	EPA 625	µg/L	2	2
Anthracene	EPA 625	µg/L	2	2
Benzidine	EPA 625	µg/L	5	5
Benzo(a)anthracene	EPA 625	µg/L	5	5
Benzo(a)pyrene	EPA 625	µg/L	2	2
Benzo(b)fluoranthene	EPA 625	µg/L	10	10
Benzo(g,h,i)perylene	EPA 625	µg/L	5	5
Benzo(k)fluoranthene	EPA 625	µg/L	2	2
Benzyl butyl phthalate	EPA 625	µg/L	10	10
bis(2-Chloroethoxy) methane	EPA 625	µg/L	5	5
bis(2-Chloroisopropyl) ether	EPA 625	µg/L	2	2
bis(2-Chloroethyl) ether	EPA 625	µg/L	1	1
bis(2-Ethylhexyl) phthalate	EPA 625	µg/L	5	5
Chrysene	EPA 625	µg/L	5	5
Dibenzo(a,h)anthracene	EPA 625	µg/L	0.1	0.1
Diethyl phthalate	EPA 625	µg/L	2	2
Dimethyl phthalate	EPA 625	µg/L	2	2
Di-n-butylphthalate	EPA 625	µg/L	10	10
Di-n-octylphthalate	EPA 625	µg/L	10	10
Fluoranthene	EPA 625	µg/L	0.05	0.05
Fluorene	EPA 625	µg/L	0.1	0.1

Parameter/Constituent	Method ⁽¹⁾	Units	Project RL	MRP Table E-2 ML
Hexachlorobenzene	EPA 625	µg/L	1	1
Hexachlorobutadiene	EPA 625	µg/L	1	1
Hexachloro-cyclo pentadiene	EPA 625	µg/L	5	5
Hexachloroethane	EPA 625	µg/L	1	1
Indeno(1,2,3-cd)pyrene	EPA 625	µg/L	0.05	0.05
Isophorone	EPA 625	µg/L	1	1
Naphthalene	EPA 625	µg/L	0.2	0.2
Nitrobenzene	EPA 625	µg/L	1	1
N-Nitroso-dimethyl amine	EPA 625	µg/L	5	5
N-Nitrosodiphenylamine	EPA 625	µg/L	1	1
N-Nitroso-di-n-propyl amine	EPA 625	µg/L	5	5
Pentachlorophenol	EPA 625	µg/L	2	2
Phenanthrene	EPA 625	µg/L	0.05	0.05
Total Phenols	EPA 625	mg/L	0.2	0.1
Phenol	EPA 625	µg/L	1	1
Pyrene	EPA 625	µg/L	0.05	0.05
Volatile Organic Compounds				
1,2,4-Trichlorobenzene	EPA 624	µg/L	1	1
1,2-Dichlorobenzene	EPA 624	µg/L	1	1
1,3-Dichlorobenzene	EPA 624	µg/L	1	1
1,4-Dichlorobenzene	EPA 624	µg/L	1	1
2-Chloroethyl vinyl ether	EPA 624	µg/L	1	1
Methyl tert-butyl ether (MTBE)	EPA 624	µg/L	1	1

RL – Reporting Limit NA – Not applicable

1. Methods may be substituted by an equivalent method that is lower than or meets the project RL.
2. Analysis for PCB congeners includes the following constituents: PCB-8, 18, 28, 31, 33, 37, 44, 49, 52, 56, 60, 66, 70, 74, 77, 81, 87, 95, 97, 99, 101, 105, 110, 114, 118, 119, 123, 126, 128, 132, 138, 141, 149, 151, 153, 156, 157, 158, 167, 168, 169, 170, 174, 177, 180, 183, 187, 189, 194, 195, 201, 203, 206, and 209.

Table 25. Analytical Methods and Reporting Limits (RLs) for Laboratory Analysis of Sediment

Parameter/Constituent	Method⁽¹⁾	Units	Project RL
General Parameters			
% Solids	EPA 1684	%	NA
Total Organic Carbon (TOC)	SM5310B	% Dry Weight	0.05
Chlordane Compounds			
alpha-Chlordane	USEPA 8081A/8270C	ng/dry g	0.5
gamma-Chlordane	USEPA 8081A/8270C	ng/dry g	0.5
Oxychlordane	USEPA 8081A/8270C	ng/dry g	0.5
trans-Nonachlor	USEPA 8081A/8270C	ng/dry g	0.5
cis-Nonachlor	USEPA 8081A/8270C	ng/dry g	0.5
Other OC Pesticides			
2,4'-DDD	USEPA 8081A/8270C	ng/dry g	0.5
2,4'-DDE	USEPA 8081A/8270C	ng/dry g	0.5
2,4'-DDT	USEPA 8081A/8270C	ng/dry g	0.5
4,4'-DDD	USEPA 8081A/8270C	ng/dry g	0.5
4,4'-DDE	USEPA 8081A/8270C	ng/dry g	0.5
4,4'-DDT	USEPA 8081A/8270C	ng/dry g	0.5
Total DDT	USEPA 8081A/8270C	ng/dry g	NA
Dieldrin	USEPA 8081A/8270C	ng/dry g	0.02
PAHs			
1-Methylnaphthalene	USEPA 8270C/8270D - SIM	ng/dry g	20
1-Methylphenanthrene	USEPA 8270C/8270D - SIM	ng/dry g	20
2-Methylnaphthalene	USEPA 8270C/8270D - SIM	ng/dry g	20
2,6-Dimethylnaphthalene	USEPA 8270C/8270D - SIM	ng/dry g	20
Acenaphthene	USEPA 8270C/8270D - SIM	ng/dry g	20
Anthracene	USEPA 8270C/8270D - SIM	ng/dry g	20
Benzo(a)anthracene	USEPA 8270C/8270D - SIM	ng/dry g	20
Benzo(a)pyrene	USEPA 8270C/8270D - SIM	ng/dry g	20
Benzo(e)pyrene	USEPA 8270C/8270D - SIM	ng/dry g	20
Biphenyl	USEPA 8270C/8270D - SIM	ng/dry g	20
Chrysene	USEPA 8270C/8270D - SIM	ng/dry g	20
Dibenzo(a,h)anthracene	USEPA 8270C/8270D - SIM	ng/dry g	20
Fluoranthene	USEPA 8270C/8270D - SIM	ng/dry g	20
Fluorene	USEPA 8270C/8270D - SIM	ng/dry g	20
Naphthalene	USEPA 8270C/8270D - SIM	ng/dry g	20
Perylene	USEPA 8270C/8270D - SIM	ng/dry g	20
Phenanthrene	USEPA 8270C/8270D - SIM	ng/dry g	20
Pyrene	USEPA 8270C/8270D - SIM	ng/dry g	20

Parameter/Constituent	Method ⁽¹⁾	Units	Project RL
Total PCBs⁽²⁾	USEPA 8270C/8270D-SIM	ng/dry g	0.2
Metals			
Copper	EPA 6010B/6020	µg/dry g	0.01
Lead	EPA 6010B/6020	µg/dry g	0.01
Zinc	EPA 6010B/6020	µg/dry g	0.1

RL – Reporting Limit NA – Not applicable

1. Methods may be substituted by an equivalent method that is lower than or meets the project RL.
2. Analysis for PCBs includes the following constituents: PCB-8, 18, 28, 31, 33, 37, 44, 49, 52, 56, 60, 66, 70, 74, 77, 81, 87, 95, 97, 99, 101, 105, 110, 114, 118, 119, 123, 126, 128, 132, 138, 141, 149, 151, 153, 156, 157, 158, 167, 168, 169, 170, 174, 177, 180, 183, 187, 189, 194, 195, 201, 203, 206, and 209.

Table 26. Analytical Methods and Reporting Limits (RLs) for Laboratory Analysis of Tissue

Parameter/Constituent	Method ⁽¹⁾	Units	Project RL
Chlordane ⁽²⁾	EPA 8270C	ng/dry g	5
Dieldrin	EPA 8270C	ng/dry g	5
PCBs ⁽³⁾	EPA 8270C	ng/dry g	5

RL – Reporting Limit NA – Not applicable

1. Methods may be substituted by an equivalent method that is lower than or meets the project RL.
2. Analysis for chlordane includes the following constituents: alpha-chlordane, gamma-chlordane, oxychlordane, cis-Nonachlor, and trans-Nonachlor.
3. Analysis for PCBs includes the following constituents: PCB-8, 18, 28, 31, 33, 37, 44, 49, 52, 56, 60, 66, 70, 74, 77, 81, 87, 95, 97, 99, 101, 105, 110, 114, 118, 119, 123, 126, 128, 132, 138, 141, 149, 151, 153, 156, 157, 158, 167, 168, 169, 170, 174, 177, 180, 183, 187, 189, 194, 195, 201, 203, 206, and 209.

Table 27. Data Quality Objectives

Parameter	Accuracy	Precision	Recovery	Completeness
Field Measurements				
Water Velocity (for Flow calc.)	2%	NA	NA	90%
pH	± 0.2 pH units	± 0.5 pH units	NA	90%
Temperature	± 0.5 °C	± 5%	NA	90%
Dissolved Oxygen	± 0.5 mg/L	± 10%	NA	90%
Turbidity	10%	10%	NA	90%
Conductivity	5%	5%	NA	90%
Laboratory Analyses – Water				
Conventionals and Solids	80 – 120%	0 – 25%	80 – 120%	90%
Aquatic Toxicity	(1)	(2)	NA	90%
Nutrients ⁽³⁾	80 – 120%	0 – 25%	90 – 110%	90%
Metals ⁽³⁾	75 – 125%	0 – 25%	75 – 125%	90%
Dioxin ⁽³⁾	50 – 150%	0 – 25%	50 – 150%	90%
Semi-Volatile Organics ⁽³⁾	50 – 150%	0 – 25%	50 – 150%	90%
Volatile Organics ⁽³⁾	50 – 150%	0 – 25%	50 – 150%	90%
Triazines ⁽³⁾	50 – 150%	0 – 25%	50 – 150%	90%
Herbicides ⁽³⁾	50 – 150%	0 – 25%	50 – 150%	90%
OC Pesticides ⁽³⁾	50 – 150%	0 – 25%	50 – 150%	90%
PCB Congeners ⁽³⁾	50 – 150%	0 – 25%	50 – 150%	90%
PCB Aroclors ⁽³⁾	50 – 150%	0 – 25%	50 – 150%	90%
OP Pesticides ⁽³⁾	50 – 150%	0 – 25%	50 – 150%	90%
Laboratory Analyses – Sediment				
% Solids	NA	NA	NA	90%
Total Organic Carbon (TOC)	80 – 120%	0 – 25%	80 – 120%	90%
OC Pesticides ⁽³⁾	25 – 140%	0 – 30%	25 – 140%	90%
PCB Congeners ⁽³⁾	60 – 125%	0 – 30%	60 – 125%	90%
PAHs ⁽³⁾	50 – 150%	0 – 25%	50 – 150%	90%
Metals ⁽³⁾	60 – 130%	0 – 30%	60 – 130%	90%
Laboratory Analyses – Tissue				
Chlordane ⁽³⁾	50 – 150%	0 – 25%	50 – 150%	90%
DDTs ⁽³⁾	35 – 140%	0 – 30%	35 – 140%	90%
Dieldrin ⁽³⁾	50 – 150%	0 – 25%	50 – 150%	90%

1. Must meet all method performance criteria relative to the reference toxicant test.
2. Must meet all method performance criteria relative to sample replicates.
3. See **Table 24**, **Table 25**, and **Table 26** for a list of individual constituents in each suite for water, sediment, and tissue, respectively.

9.2.1 Method Detection Limit Studies

Any laboratory performing analyses under this program must routinely conduct MDL studies to document that the MDLs are less than or equal to the project-specified RLs. If any analytes have MDLs that do not meet the project RLs, the following steps must be taken:

- Perform a new MDL study using concentrations sufficient to prove analyte quantitation at concentrations less than or equal to the project-specified RLs per the procedure for the Determination of the Method Detection Limit presented in Revision 1.1, 40 Code of Federal Regulations (CFR) 136, 1984.
- No samples may be analyzed until the issue has been resolved. MDL study results must be available for review during audits, data review, or as requested. Current MDL study results must be reported for review and inclusion in project files.

An MDL is developed from seven aliquots of a standard containing all analytes of interest spiked at five times the expected MDL. These aliquots are processed and analyzed in the same manner as environmental samples. The results are then used to calculate the MDL. If the calculated MDL is less than 0.33 times the spiked concentration, another MDL study should be performed using lower spiked concentrations.

9.2.2 Project Reporting Limits

Laboratories generally establish RLs that are reported with the analytical results—these may be called reporting limits, detection limits, reporting detection limits, or several other terms by the reporting laboratory. These laboratory limits must be less than or equal to the project RLs listed in **Table 24**. Wherever possible, project RLs are lower than the relevant numeric criteria or toxicity thresholds. Laboratories performing analyses for this project must have documentation to support quantitation at the required levels.

9.2.3 Laboratory Standards and Reagents

All stock standards and reagents used for standard solutions and extractions must be tracked through the laboratory. The preparation and use of all working standards must be documented according to procedures outlined in each laboratory's Quality Assurance (QA) Manual; standards must be traceable according to USEPA, A2LA or National Institute for Standards and Technology (NIST) criteria. Records must have sufficient detail to allow determination of the identity, concentration, and viability of the standards, including any dilutions performed to obtain the working standard. Date of preparation, analyte or mixture, concentration, name of preparer, lot or cylinder number, and expiration date, if applicable, must be recorded on each working standard.

9.2.4 Sample Containers, Storage, Preservation, and Holding Times

Sample containers must be pre-cleaned and certified free of contamination according to the USEPA specification for the appropriate methods. Sample container, storage and preservation, and holding time requirements are provided in **Table 28**. The analytical laboratories will supply sample containers that already contain preservative (**Table 28**), including ultra-pure hydrochloric and nitric acid, where applicable. After collection, samples will be stored at 4°C until arrival at the contract laboratory. Note that sample containers, volumes, storage, processing, and holding

requirements may vary according to analytical method and laboratory. Typical requirements based on the methods listed in **Table 24**, **Table 25**, and **Table 26** are provided in **Table 28**, but are subject to change upon selection and consultation with the analytical laboratory.

Table 28. Sample Container, Sample Volume, Initial Preservation, and Holding Time Requirements for Parameters Analyzed at a Laboratory

Parameter	Sample Container	Sample Volume ⁽¹⁾	Immediate Processing and Storage	Holding Time
Water				
Toxicity				
Initial Screening	Glass or FLPE-lined jerrican	20 L	Store at 4°C	36 hours ⁽²⁾
Phase I TIE				
E. coli (fresh)	PE	120 mL	Na ₂ S ₂ O ₃ and Store at 4°C	8 hours
Oil and Grease	Glass	1 L	HCl or H ₂ SO ₄ to pH<2 and Store at 4°C	28 days
Chlorophyll a	Amber PE	1 L	Store at 4°C	Filter w/in 48 hours, 28 days
Cyanide	PE	500 mL	NaOH to pH>10, Add reducing agent if oxidizer present, and Store at 4°C	14 days
Dissolved Organic Carbon (DOC)	PE	250 mL	Store at 4°C	Filter/28 days
Total Organic Carbon (TOC)	PE	250 mL	H ₂ SO ₄ to pH<2 and Store at 4°C	28 days
Total Petroleum Hydrocarbon	Glass	1 L	HCl or H ₂ SO ₄ and Store at 4°C	7/40 days ⁽³⁾
Biochemical Oxygen Demand	PE	1 L	Store at 4°C	48 hours
Chemical Oxygen Demand	PE	500 mL	H ₂ SO ₄ to pH<2 and Store at 4°C	28 days
MBAS	PE	1 L	Store at 4°C	48 hours
Fluoride	PE	500 mL	None required	28 days
Chloride				28 days
Sulfate	PE	250 mL	Store at 4°C	28 days
Boron	PE	250-mL	Store at 4°C	180 days
Perchlorate	PE	500 mL	Store at 4°C	28 days
Nitrate Nitrogen				
Nitrite Nitrogen	PE	250 mL	Store at 4°C	48 hours
Orthophosphate-P or Dissolved Phosphorus				

Parameter	Sample Container	Sample Volume ⁽¹⁾	Immediate Processing and Storage	Holding Time
Ammonia Nitrogen	PE or Glass	250-mL	H ₂ SO ₄ to pH<2 and Store at 4°C	28 days
Total Phosphorus				
Organic Nitrogen				
Nitrate + Nitrite (as N)				
Total Kjeldahl Nitrogen (TKN)	PE	250 mL	H ₂ SO ₄ to pH<2 and Store at 4°C	28 days
Total Alkalinity	PE	500 mL	Store at 4°C	14 days
Suspended Sediment Concentration (SSC)	PE	250 mL	Store at 4°C	120 days
Total Suspended Solids (TSS)	PE	250 mL	Store at 4°C	7 days
Total Dissolved Solids (TDS)	PE	250 mL	Store at 4°C	7 days
Volatile Suspended Solids	PE	250 mL	Store at 4°C	7 days
Hardness	PE	1 L	HNO ₃ to pH<2 (or H ₂ SO ₄ to pH<2 for Hardness) and Store at 4°C	180 days
Metals				6 months ⁽⁴⁾
Mercury	Glass	500 mL	HNO ₃ to pH<2 and Store at 4°C	28 days
Dioxin	Amber glass	2 x 1 L	Store at 4°C	1 year
PCBs, OC Pesticides, OP Pesticides, Triazine Pesticides	Amber glass	4 x 1 L	Store at 4°C	7/40 days ⁽³⁾
Suspended Solids Analysis for Organics	Amber glass	20 x 1 L	Store at 4°C	7/40 days ⁽³⁾
Herbicides	Glass	2 x 40 mL	Thiosulfate and Store at 4°C	14 days
Semivolatile Organic Compounds	Glass	2 x 1 L	Store at 4°C	7 days
Volatile Organic Compounds	VOA	3 x 40 mL	HCl and Store at 4°C	14 days
Sediment				
% Solids	Glass	2 x 8 oz jar	Store at 4°C	7 days
Total Organic Carbon (TOC)				1 year ⁽⁶⁾
OC Pesticides, PCBs, PAHs				1 year ⁽⁵⁾
Metals				
Tissue				
% Lipids	Teflon sheet	200 g	Store on dry ice	1 year ⁽⁵⁾
Chlordane				
DDTs				
Dieldrin				

PE – Polyethylene

1. Additional volume may be required for QC analyses and/or equivalent substitute method or for multiple species toxicity testing.
2. Tests should be initiated within 36 hours of collection. The 36-hour hold time does not apply to subsequent analyses for TIEs. For interpretation of toxicity results, samples may be split from toxicity samples in the laboratory and analyzed for specific chemical parameters. All other sampling requirements for these samples are as specified in this document for the specific analytical method. Results of these analyses are not for any other use (e.g., characterization of ambient conditions) because of potential holding time exceedances and variance from sampling requirements.
3. 7/40 = 7 days to extract and 40 days from extraction to analysis.
4. 6 months after preservation.
5. One year if frozen, otherwise 14 days to extract and 40 days from extraction to analysis.
6. One year if frozen, otherwise 28 days.

9.3 Aquatic Toxicity Testing and Toxicity Identification Evaluations

Aquatic toxicity testing supports the identification of BMPs to address sources of toxicity in urban runoff. Monitoring begins in the receiving water and the information gained is used to identify constituents for monitoring at outfalls to support the identification of pollutants that need to be addressed in the EWMP. The subsections below describe the detailed process for conducting aquatic toxicity monitoring, evaluating results, and the technical and logistical rationale. Control measures and management actions to address confirmed toxicity caused by urban runoff are addressed by the EWMP, either via currently identified management actions or those that are identified via adaptive management of the EWMP.

9.3.1 Sensitive Species Selection

The MRP (page E-32) states that a sensitivity screening to select the most sensitive test species should be conducted unless “a sensitive test species has already been determined, or if there is prior knowledge of potential toxicant(s) and a test species is sensitive to such toxicant(s), then monitoring shall be conducted using only that test species.” Previous relevant studies conducted in the watershed should be considered. Such studies may have been completed via previous MS4 sampling, wastewater NPDES sampling, or special studies conducted within the watershed. The following discuss the species selection process for assessing aquatic toxicity in receiving waters.

As described in the MRP (page E-31), if samples are collected in receiving waters with salinity less than 1 part per thousand (ppt), or from outfalls discharging to receiving waters with salinity less than 1 ppt, toxicity tests should be conducted on the most sensitive test species in accordance with species and short-term test methods in Short-term Methods for Estimating the Chronic Toxicity of Effluents and Receiving Waters to Freshwater Organisms (EPA/821/R-02/013, 2002; Table IA, 40 CFR Part 136). The freshwater test species identified in the MRP are:

- A static renewal toxicity test with the fathead minnow, *Pimephales promelas* (Larval Survival and Growth Test EPA Method 1000.0).
- A static renewal toxicity test with the daphnid, *Ceriodaphnia dubia* (Survival and Reproduction Test EPA Method 1002.0).
- A static non-renewal toxicity test with the green alga, *Selenastrum capricornutum* (also named *Raphidocelis subcapitata*) (Growth Test EPA Method 1003.0).

The three test species were evaluated to determine if either a sensitive test species had already been determined, or if there is prior knowledge of potential toxicant(s) and a test species is sensitive to such toxicant(s). In reviewing the available data in the ULAR watershed, metals, historical organics, and currently used pesticides have been identified as problematic and are generally considered the primary aquatic life toxicants of concern found in urban runoff. Given the knowledge of the presence of these potential toxicants in the watershed, the sensitivities of each of the three species were considered to evaluate which is the most sensitive to the potential toxicants in the watershed.

Ceriodaphnia dubia (*C. dubia*) has been reported as a sensitive test species for historical and current use pesticides and metals, and studies indicate that it is more sensitive to the toxicants of concern than *Pimephales promelas* (*P. promelas*) or *Selenastrum capricornutum* (*S. capricornutum*). In *Aquatic Life Ambient Freshwater Quality Criteria - Copper*, the USEPA reports greater sensitivity of *C. dubia* to copper (species mean acute value of 5.93 µg/l) compared to *P. promelas* (species mean acute value of 69.93 µg/l; EPA, 2007). *C. dubia*'s relatively higher sensitivity to metals is common across multiple metals. Additionally, researchers at the University of California (UC), Davis reviewed available reported species sensitivity values in developing pesticide criteria for the Central Valley Regional Water Quality Control Board (CVRWQCB). The UC Davis researchers reported higher sensitivity of *C. dubia* to diazinon and bifenthrin (species mean acute value of 0.34 µg/l and 0.105 µg/l) compared to *P. promelas* (species mean acute value of 7804 µg/l and 0.405 µg/l; Palumbo et al., 2010a,b). Additionally, a study of the City of Stockton urban stormwater runoff found acute and chronic toxicity response to *C. dubia*, with no toxicity response to *S. capricornutum* or *P. promelas* (Lee and Lee, 2001). The toxicity was attributed to organophosphate pesticides, indicating a higher sensitivity of *C. dubia* compared to *S. capricornutum* or *P. promelas*. *C. dubia* is also the test organism selected to assess the ambient toxicity of the Los Angeles River by the Los Angeles River Watershed Monitoring Program and has been the most-sensitive species to the Donald C. Tillman and the Los Angeles-Glendale Water Reclamation Plant effluent as well as the Los Angeles River receiving water in the vicinity of the water treatment plants. While *P. promelas* is generally less sensitive to metals and pesticides, this species can be more sensitive to ammonia than *C. dubia*. However, as ammonia is not typically a constituent of concern for urban runoff and ammonia is not consistently observed above the toxic thresholds in the watershed, *P. promelas* is not considered a particularly sensitive species for evaluating the impacts of urban runoff in receiving waters in this watershed.

S. capricornutum is a species sensitive to herbicides. However, while sometimes present in urban runoff, herbicides are not identified as a potential toxicant in this watershed. Additionally, *S. capricornutum* is not considered the most sensitive species as it is not sensitive to pyrethroids or organophosphate pesticides and is not as sensitive to metals as *C. dubia*. Additionally, the *S. capricornutum* growth test can be affected by high concentrations of suspended and dissolved solids, color, and pH extremes, which can interfere with the determination of sample toxicity. As a result, it is common to manipulate the sample by centrifugation and filtration to remove solids to conduct the test; however, this process may affect the toxicity of the sample. In a study of urban highway stormwater runoff (Kayhanian et. al, 2008), *S. capricornutum*'s response to the stormwater samples was more variable than the *C. dubia* and the *P. promelas* and in some cases the algal growth was possibly enhanced due to the presence of stimulatory nutrients. Also, in a

study on the City of Stockton urban stormwater runoff (Lee and Lee, 2001) the *S. capricornutum* tests rarely detected toxicity where the *C. dubia* and the *P. promelas* regularly detected toxicity.

As *C. dubia* is identified as the most sensitive to known potential toxicant(s) typically found in receiving waters and urban runoff in the freshwater portions of this watershed, *C. dubia* is selected as the most sensitive species. The species also has the advantage of being easily maintained by means of in-house mass cultures. The relative ease of test preparation, the ease of interpreting results, and the smaller volume necessary to run the test, make the test a valuable screening tool. The ease of sample collection and higher sensitivity will support assessing the presence of ambient receiving water toxicity or long term effects of toxic stormwater over time. As such, toxicity testing in the freshwater portions of the watershed will be conducted using *C. dubia*. However, *C. dubia* test organisms are typically cultured in moderately hard waters (80-100 mg/L CaCO₃) and can have increased sensitivity to elevated water hardness greater than 400 mg/L CaCO₃, which is beyond their typical habitat range. Because of this, in instances where hardness in site waters exceeds 400 mg/L (CaCO₃), an alternative test species may be used. *Daphnia magna* is more tolerant to high hardness levels and is a suitable substitution for *C. dubia* in these instances (Cowgill and Milazzo, 1990).

9.3.2 Testing Period

The following describes the testing periods to assess toxicity in samples collected in the ULARWMAG EWMP area during dry and wet weather conditions. Although wet weather conditions in the region generally persist for less than the chronic testing periods (typically 7 days), the *C. dubia* chronic test method will be used for wet weather toxicity testing in accordance with Short-term Methods for Estimating the Chronic Toxicity of Effluents and Receiving Waters to Freshwater Organisms (EPA, 2002b). Utilization of chronic tests on wet weather samples are not expected to generate results representative of the typical conditions found in the receiving water intended to be simulated by toxicity testing.

Chronic toxicity tests will be used to assess both survival and reproductive/growth endpoints for *C. dubia* in dry weather samples. Chronic testing will be conducted on undiluted grab samples in accordance with *Short-term Methods for Estimating the Chronic Toxicity of Effluents and Receiving Waters to Freshwater Organisms* (USEPA, 2002a).

9.3.3 Toxicity Endpoint Assessment and Toxicity Identification Evaluation Triggers

Per the MRP, toxicity test endpoints will be analyzed using the Test of Significant Toxicity (TST) t-test approach specified by the USEPA (USEPA, 2010). The Permit specifies that the chronic in-stream waste concentration (IWC) is set at 100% receiving water for receiving water samples and 100% effluent for outfall samples. Using the TST approach, a t-value is calculated for a test result and compared with a critical t-value from USEPA's TST Implementation Document (USEPA, 2010). Follow-up triggers are generally based on the Permit specified statistical assessment as described below.

For acute *C. dubia* toxicity testing, if a $\geq 50\%$ reduction in survival or reproduction is observed between the sample and laboratory control that is statistically significant, a toxicity identification evaluation (TIE) will be performed.

TIE procedures will be initiated as soon as possible after the toxicity trigger threshold is observed to reduce the potential for loss of toxicity due to extended sample storage. If the cause of toxicity is readily apparent or is caused by pathogen related mortality (PRM) or epibiont interference with the test, the result will be rejected. If necessary, a modified testing procedure will be developed for future testing.

In cases where significant endpoint toxicity effects greater than 50% are observed in the original sample, but the follow-up TIE baseline “signal” is not statistically significant, the cause of toxicity will be considered non-persistent. No immediate follow-up testing is required on the sample. However, future test results should be evaluated to determine if parallel TIE treatments are necessary to provide an opportunity to identify the cause of toxicity.

9.3.4 Toxicity Identification Evaluation Approach

The results of toxicity testing will be used to trigger further investigations to determine the cause of observed laboratory toxicity. The primary purpose of conducting TIEs is to support the identification of management actions that will result in the removal of pollutants causing toxicity in receiving waters. Successful TIEs will direct monitoring at outfall sampling sites to inform management actions. As such, the goal of conducting TIEs is to identify pollutant(s) that should be sampled during outfall monitoring so that management actions can be identified to address the pollutant(s).

The TIE approach is divided into three phases as described in USEPA’s 1991 Methods for Aquatic Toxicity Identification Evaluations – Phase I Toxicity Characterization Procedures – Second Edition (EPA/600/6-9/003) and briefly summarized as follows:

- Phase I utilizes methods to characterize the physical/chemical nature of the constituents which cause toxicity. Such characteristics as solubility, volatility and filterability are determined without specifically identifying the toxicants. Phase I results are intended as a first step in specifically identifying the toxicants but the data generated can also be used to develop treatment methods to remove toxicity without specific identification of the toxicants.
- Phase II utilizes methods to specifically identify toxicants.
- Phase III utilizes methods to confirm the suspected toxicants.

A Phase I TIE will be conducted on samples that exceed a TIE trigger described above. Water quality data will be reviewed to further support evaluation of potential toxicants. A range of sample manipulations may be conducted as part of the TIE process. The most common manipulations are described in **Table 29**. Information from previous chemical testing and/or TIE efforts will be used to determine which of these (or other) sample manipulations are most likely to provide useful information for identification of primary toxicants. TIE methods will generally adhere to USEPA procedures documented in conducting TIEs (USEPA, 1991, 1992, 1993a-b).

Table 29. Aquatic Toxicity Identification Evaluation Sample Manipulations

TIE Sample Manipulation	Expected Response
pH Adjustment (pH 7 and 8.5)	Alters toxicity in pH sensitive compounds (i.e., ammonia and some trace metals)
Filtration or centrifugation ⁽¹⁾	Removes particulates and associated toxicants
Ethylenediamine-Tetraacetic Acid (EDTA) or Cation Exchange Column ⁽¹⁾	Chelates trace metals, particularly divalent cationic metals
Sodium thiosulfate (STS) addition	Reduces toxicants attributable to oxidants (i.e., chlorine) and some trace metals
Piperonyl Butoxide (PBO) ⁽¹⁾	Reduces toxicity from organophosphate pesticides such as diazinon, chlorpyrifos and malathion, and enhances pyrethroid toxicity
Carboxylesterase addition ⁽²⁾	Hydrolyzes pyrethroids
Temperature adjustments ⁽³⁾	Pyrethroids become more toxic when test temperatures are decreased
Solid Phase Extraction (SPE) with C18 column ⁽¹⁾	Removes non-polar organics (including pesticides) and some relatively non-polar metal chelates
Sequential Solvent Extraction of C18 column	Further resolution of SPE-extracted compounds for chemical analyses
No Manipulation ⁽¹⁾	Baseline test for comparing the relative effectiveness of other manipulations

1. Denotes treatments that will be conducted during the initiation of toxicity monitoring, but may be revised as the program is implemented. These treatments were recommended for initial stormwater testing in Appendix E (Toxicity Testing Tool for Storm Water Discharges) of the State Water Resources Control Board's June 2012 Public Review Draft "Policy for Toxicity Assessment and Control".
2. Carboxylesterase addition has been used in recent studies to help identify pyrethroid-associated toxicity (Wheelock et al., 2004; Weston and Amweg, 2007). However, this treatment is experimental in nature and should be used along with other pyrethroid-targeted TIE treatments (e.g., PBO addition).
3. Temperature adjustments are another recent manipulation used to evaluate pyrethroid-associated toxicity. Lower temperatures increase the lethality of pyrethroid pesticides. (Harwood, You and Lydy, 2009)

The ULARWMAG will identify the cause(s) of toxicity using a selection of treatments in **Table 29** and, if possible, using the results of water column chemistry analyses. After any initial determinations of the cause of toxicity, the information may be used during future events to modify the targeted treatments to more closely target the expected toxicant or to provide additional treatments to narrow the toxicant cause(s). Moreover, if the toxicant or toxicant class is not initially identified, toxicity monitoring during subsequent events will confirm if the toxicant is persistent or a short-term episodic occurrence.

As the primary goal of conducting TIEs is to identify pollutants for incorporation into outfall monitoring, narrowing the list of toxicants following Phase I TIEs via Phase II or III TIEs is not necessary if the toxicant class determined during the Phase I TIE is sufficient for: (1) identifying additional pollutants for outfall monitoring; and/or (2) identifying control measures. Thus, if the specific pollutant(s) or the analytical class of pollutant(s) (e.g., metals that are analyzed via

USEPA Method 200.8) are identified then sufficient information is available to inform the addition of pollutants to outfall monitoring.

Phase II TIEs may be utilized to identify specific constituents causing toxicity in a given sample if the results of Phase I TIE testing and a review of available chemistry data fails to provide information necessary to identify constituents that warrant additional monitoring activities or management actions to identify likely sources of the toxicants and lead to elimination of the sources of these contaminants. Phase III TIEs will be conducted following any Phase II TIEs.

For the purposes of determining whether a TIE is inconclusive, TIEs will be considered inconclusive if:

- The toxicity is persistent (i.e., observed in the baseline), and
- The cause of toxicity cannot be attributed to a class of constituents (e.g., insecticides, metals, etc.) that can be targeted for monitoring.

If (1) a combination of causes that act in a synergistic or additive manner are identified; (2) the toxicity can be removed with a treatment or via a combination of the TIE treatments; or (3) the analysis of water quality data collected during the same event identify the pollutant or analytical class of pollutants, the result of a TIE is considered conclusive.

In cases where significant endpoint toxicity effects $\geq 50\%$ are observed in the original sample, but the follow-up TIE baseline “signal” is not statistically significant, the cause of toxicity will be considered non-persistent. No immediate follow-up testing is required on the sample. However, future test results should be evaluated to determine if parallel TIE treatments are necessary to provide an opportunity to identify the cause of toxicity.

Note that the MRP (page E-33) allows a TIE Prioritization Metric (as described in Appendix E of the Southern California Stormwater Monitoring Coalition’s (SMC) Model Monitoring Program) for use in ranking sites for TIEs. However, as the extent to which TIEs will be conducted is unknown, prioritization cannot be conducted at this time. However, prioritization may be utilized in the future based on the results of toxicity monitoring and an approach to prioritization will be developed through the CIMP adaptive management process and will be described in future versions of the CIMP.

9.3.5 Follow Up on Toxicity Testing Results

Per Parts VIII.B.c.vi and XI.G.1.d of the MRP, if the results of a TIE on a receiving sample are inconclusive, a toxicity test conducted during the same condition (i.e., wet or dry weather), using the same test species, will be conducted at applicable upstream outfalls as soon as feasible (i.e., the next monitoring event that is at least 45 days following the toxicity laboratory’s report transmitting the results of a inconclusive TIE). The same TIE approach presented in **Sections 9.3.3** and **9.3.4**, respectively will be followed based on the results of the outfall sample.

If a toxicant or class of toxicants is identified through a TIE, the MRP (page E-33) indicates the following actions should be taken when a toxicant or class of toxicants is identified through a TIE:

- ULARWMAG Members shall analyze for the toxicant(s) during the next scheduled sampling event in the discharge from the outfall(s) upstream of the receiving water location.
- If the toxicant is present in the discharge from the outfall at levels above the applicable receiving water limitation, a toxicity reduction evaluation (TRE) will be performed for that toxicant.

The list of constituents monitored at outfalls identified in the CIMP will be modified based on the results of the TIEs. Monitoring for constituents identified based on the results of a TIE will occur as soon as feasible following the completion of a successful TIE (i.e., the next monitoring event that is at least 45 days following the toxicity laboratory's report transmitting the results of a successful TIE).

The requirements of the TREs will be met as part of the adaptive management process in the ULAR EWMP rather than conducted via the CIMP. The identification and implementation of control measures to address the causes of toxicity are tied to management of the stormwater program, not the CIMP. It is expected that the requirements of TREs will only be conducted for toxicants that are not already addressed by an existing Permit requirement (i.e., TMDLs) or existing or planned management actions.

9.3.6 Summary of Aquatic Toxicity Monitoring

The approach to conducting aquatic toxicity monitoring as described in the previous sections of this Attachment is summarized in **Figure 10**. The intent of the approach is to identify the cause of toxicity observed in receiving water to the extent possible with the toxicity testing tools available, thereby directing outfall monitoring for the pollutants causing toxicity with the ultimate goal of supporting the development and implementation of management actions.

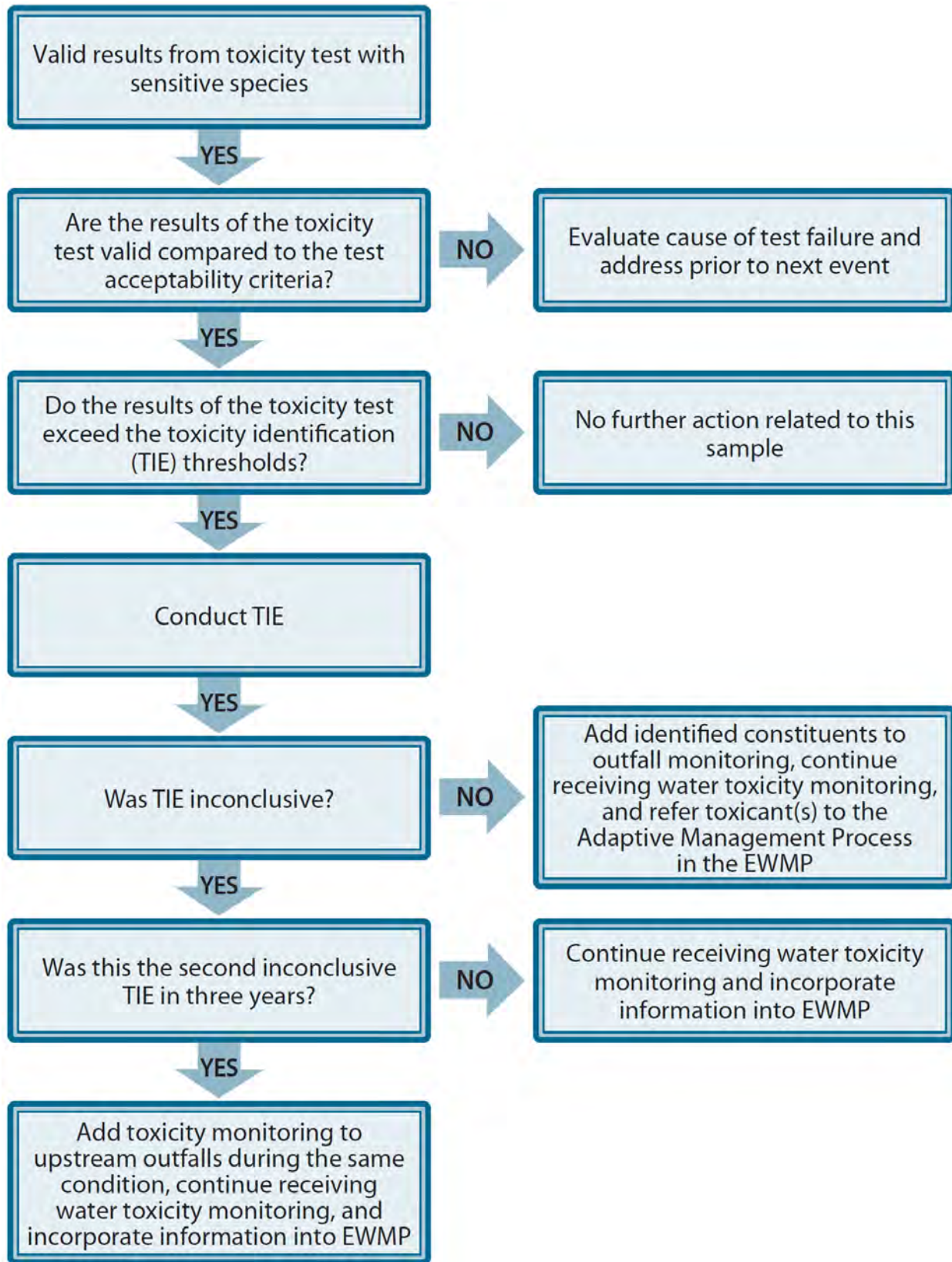

Figure 10. Detailed Aquatic Toxicity Assessment Process

9.4 Bio-Assessment/Macroinvertebrate Community Assessment

The LACFCD has indicated that it will continue its participation in the SMC Regional Bioassessment Monitoring Program on behalf of the ULARWMAG. Thus no specific monitoring and analytical procedures are included in the CIMP at this time. If in the future, such monitoring is necessary under this program, the CIMP will be revised to include appropriate procedures.

9.4.1 List of Laboratories Conducting Analysis

The chosen laboratories will be able to meet the measurement quality objectives set forth in **Table 24** through **Table 27**. Laboratories will meet California Environmental Laboratory Accreditation Program (ELAP) and/or National Environmental Laboratory Accreditation Program (NELAP) certifications and any data quality requirements specified in this document. Due to contracting procedures and solicitation requirements, qualified laboratories have not yet been selected to carry out the analytical responsibilities described in this CIMP. Selected laboratories will be listed along with lab certification information in **Table 30**. Following the completion of the first monitoring year, the CIMP will be updated to include the pertinent laboratory specific information. At the end of all future monitoring years the ULARWMAG will assess the laboratories performance and at that time a new laboratory may be chosen.

Table 30. Summary of Laboratories Conducting Analysis for the ULARWMAG CIMP

Laboratory ⁽¹⁾	General Category of Analysis	Lab Certification No. & Expiration Date ⁽²⁾

1. Information for all laboratories will be added to this table following their selection and upon CIMP update.
2. Lab certifications are renewed on an annual basis.

9.4.1.1 Alternate Laboratories

In the event that the laboratories selected to perform analyses for the CIMP are unable to fulfill data quality requirements outlined herein (e.g., due to instrument malfunction), alternate laboratories need to meet the same requirements that the primary labs have met. The original laboratory selected may recommend a qualified laboratory to act as a substitute. However, the final decision regarding alternate laboratory selection rests with the ULARWMAG.

10 Sampling Methods and Sample Handling

The following sections describe the steps to be taken to properly prepare for and initiate water quality sampling for the CIMP.

10.1 Monitoring Event Preparation

Monitoring event preparation includes preparation of field equipment, placing bottle orders, and contacting the necessary personnel regarding site access and schedule. The following steps will be completed two weeks prior to each sampling event (a condensed timeline may be appropriate in storm events, which may need to be completed on short notice):

1. Contact laboratories to order sample containers and to coordinate sample transportation details.
2. Confirm scheduled monitoring date with field crew(s), and set-up sampling day itinerary including sample drop-off.
3. Prepare equipment.
4. Prepare sample container labels and apply to bottles.
5. Prepare the monitoring event summary and field log sheets to indicate the type of field measurements, field observations and samples to be collected at each of the monitoring sites.
6. Verify that field measurement equipment is operating properly (i.e., check batteries, calibrate, etc.)

Table 31 provides a checklist of field equipment to prepare prior to each monitoring event.

Table 31. Field Equipment Checklist

<input type="checkbox"/>	Monitoring Plan
<input type="checkbox"/>	Sample Containers plus Extras with Extra Lids
<input type="checkbox"/>	Pre-Printed, Waterproof Labels (extra blank sheets)
<input type="checkbox"/>	Event Summary Sheets
<input type="checkbox"/>	Field Log Sheets or Electronic Device (e.g., laptop or tablet computer)
<input type="checkbox"/>	Chain of Custody Forms
<input type="checkbox"/>	Bubble Wrap
<input type="checkbox"/>	Coolers with Ice
<input type="checkbox"/>	Tape Measure
<input type="checkbox"/>	Paper Towels or “Rags in a Box”
<input type="checkbox"/>	Safety Equipment
<input type="checkbox"/>	First Aid Kit
<input type="checkbox"/>	Cellular Telephone
<input type="checkbox"/>	Gate Keys
<input type="checkbox"/>	Hip Waders
<input type="checkbox"/>	Plastic Trash Bags
<input type="checkbox"/>	Sealable Plastic Bags
<input type="checkbox"/>	Grab Pole and/or Fishing Pole
<input type="checkbox"/>	Clean Secondary Container(s)
<input type="checkbox"/>	Field Measurement Equipment
<input type="checkbox"/>	New Powder-Free Nitrile Gloves
<input type="checkbox"/>	Writing Utensils
<input type="checkbox"/>	Stop Watch
<input type="checkbox"/>	Camera
<input type="checkbox"/>	Blank Water

10.1.1 Bottle Order/Preparation

Sample container orders will be placed with the appropriate analytical laboratory at least two weeks prior to each sampling event. Containers will be ordered for all water samples, including quality control samples, as well as extra containers in case the need arises for intermediate containers or a replacement. The containers must be the proper type and size and contain preservative as appropriate for the specified laboratory analytical methods. **Table 28** presents the proper container type, volume, and immediate processing and storage needs. The field crew must inventory sample containers upon receipt from the laboratory to ensure that adequate containers have been provided to meet analytical requirements for each monitoring event. After each event, any bottles used to collect water samples will be cleaned by the laboratory and either picked up by or shipped to the field crew.

10.1.2 Container Labeling and Sample Identification Scheme

All samples will be identified with a unique identification code to ensure that results are properly reported and interpreted. Samples will be identified such that the site, sampling location, matrix, sampling equipment and sample type (i.e., environmental sample or QC sample) can be distinguished by a data reviewer or user. The following provides a container and sample identification scheme that could be used. However, alternative sample and data management schemes can be used if they provide the essential information listed here. Sample identification codes may consist of a site identification code, a matrix code, and a unique sample identification code. An example format for sample identification codes is ULAR- ####.# - AAAA - XXX, where:

- ULAR indicates that the sample was collected as part of the ULARWMAG CIMP.
- ####.# - identifies the sequentially numbered monitoring event, and the decimal (.#) is an optional indicator for re-samples collected for the same event. Sample events are numbered from 001 to 999 and will not be repeated.
- AAAA indicates the unique site ID for each site.
- XXX identifies the sample number unique to a sample bottle collected for a single event. Sample bottles are numbered sequentially from 001 to 999 and will not be repeated within a single event.

Custom bottle labels should be produced using blank waterproof labels and labeling software. This approach will allow the site and analytical constituent information to be entered in advance and printed as needed prior to each monitoring event. Labels will be placed on the appropriate bottles in a dry environment; applying labels to wet sample bottles should be avoided. Labels should be placed on sides of bottles rather than on bottle caps. All sample containers will be pre-labeled before each sampling event to the extent practicable. Pre-labeling sample containers simplifies field activities, leaving only sample collection time and date and field crew initials to be filled out in the field. Labels should include the following information:

Program Name	Date	Analytical Requirements
Station ID	Collection Time	Preservative Requirements
Sample ID	Sampling Personnel and Agency/Firm	Analytical Laboratory

10.1.3 Field Meter Calibration

Calibration of field measurement equipment is performed as described in the owner's manuals for each individual instrument. Each individual field crew will be responsible for calibrating their field measurement equipment. Field monitoring equipment must meet the requirements outlined in **Table 23** and be calibrated before field events based on manufacturer guidance, but at a minimum prior to each event. **Table 32** outlines the typical field instrument calibration procedures for each piece of equipment requiring calibration. Each calibration will be documented on each event's calibration log sheet (presented in **Appendix 1**).

If calibration results do not meet manufacturer specifications, the field crew should first try to recalibrate using fresh aliquots of calibration solution. If recalibration is unsuccessful, new

calibration solution should be used and/or maintenance should be performed. Each attempt should be recorded on the equipment calibration log. If the calibration results cannot meet manufacturer’s specifications, the field crew should use a spare field measuring device that can be successfully calibrated. If a spare field measuring device that can be successfully calibrated is unavailable, field crews shall note the use of unsuccessfully calibrated equipment on each appropriate field log sheet. Additionally, the ULARWMAG should be notified.

Calibration should be verified using at least one calibration fluid within the expected range of field measurements, both immediately following calibration and at the end of each monitoring day. Individual parameters should be recalibrated if the field meters do not measure a calibration fluid within the range of accuracy presented in **Table 23**. Calibration verification documentation will be retained in the event’s calibration verification log (presented in **Appendix 1**).

Table 32. Calibration of Field Measurement Equipment

Equipment / Instrument	Calibration and Verification Description	Frequency of Calibration	Frequency of Calibration Verification	Responsible Party
pH Probe	Calibration for pH measurement is accomplished using standard buffer solutions. Analysis of a mid-range buffer will be performed to verify successful calibration.			
Temperature	Temperature calibration is factory-set and requires no subsequent calibration.			
Dissolved Oxygen Probe	Calibration for dissolved oxygen measurements is accomplished using a water saturated air environment. Dissolved oxygen (DO) measurement of water-saturated air will be performed and compared to a standard table of DO concentrations in water as a function of temperature and barometric pressure to verify successful calibration.	Day prior to 1st day or 1st day of sampling event	After calibration and at the end of each sampling day	Individual Sampling Crews
Conductivity	Conductivity calibration will follow manufacturer’s specifications. A mid-range conductivity standard will be analyzed to verify successful calibration.			
Turbidity	Turbidity calibration will follow manufacturer’s specifications. A mid-range turbidity standard will be analyzed to verify successful calibration.			

10.1.4 Weather Conditions

Monitoring will occur during dry and wet conditions. Dry weather is defined in the MRP as when the flow of the receiving water body is less than 20 percent greater than the base flow or as defined by effective TMDLs within the watershed. Wet weather conditions are defined in the

MRP as when the receiving water body has flow that is at least 20 percent greater than its base flow or as defined by effective TMDLs within the watershed. TMDLs within the ULAR watershed have defined wet weather as when the maximum daily flow rate is equal to or greater than 500 cubic feet per second (cfs) and dry weather as below 500 cfs at LACDPW Wardlow Road flow gage. As such, for the purposes of the ULARWMAG CIMP, weather conditions will be defined as follows:

- **Dry Weather:** When the flow of the receiving water body is less than 500 cfs at LACDPW Wardlow Road flow gage or an equivalent flow rate at the monitoring site² **and** when there is less than 0.1 inch of rain in the previous three days.
- **Wet Weather:** When the flow of the receiving water body is equal to or greater than 500 cfs at LACDPW Wardlow Road flow gage or an equivalent flow rate at the monitoring site³ **and** when there is at least 0.1 inch of rain during the targeted storm event.

Note that if rainfall begins after dry weather monitoring has been initiated, then dry weather monitoring will be suspended and continued on a subsequent day when weather conditions meet the dry weather conditions. Generally, grab samples will be collected during dry weather and composite samples will be collected during wet weather. Grab samples will be used for dry weather sampling events because the composition of the receiving water will change less over time; and thus, the grab sample can sufficiently characterize the receiving water. Grab samples during dry weather are consistent with similar programs within the region. However, to sufficiently characterize the receiving water during wet weather, composite samples will generally be used for wet weather sampling events. Grab samples may be utilized to collect wet weather sampling in certain situations, which may include, but are not limited to, when the constituent of interest requires the use of grab samples (e.g., *E. coli* and oil and grease), situations where it is unsafe to collect composite samples, or to perform investigative monitoring where composite sampling or installation of an automatic sample compositor (autosampler) may not be warranted. For safety purposes, when wet weather grab sampling is conducted, samples may be taken from slightly upstream or downstream of the designated monitoring location.

The MRP includes specific criteria for the time of monitoring events. With the exception of bacteria and metals monitoring, most constituents will be monitored during two dry weather monitoring events. For dry weather toxicity monitoring, sampling must take place during the month with the historically lowest flows. As a result, the dry weather monitoring event that includes toxicity monitoring will be conducted in August. The second dry weather monitoring event will take place during February unless sampling during another month is deemed to be necessary or preferable.

All reasonable efforts will be made to monitor the first significant rain event of the storm year (first flush). The targeted storm events for wet weather sampling will be selected based on a reasonable probability that the events will result in substantially increased flows in the ULAR over at least 12 hours; however, it may be necessary to target smaller storms in some instances. Sufficient precipitation is needed to produce runoff and increase flow. The decision to sample a

² The wet weather flow trigger for an individual receiving water monitoring location will be set at an appropriate value given where the monitoring location is situated within the watershed.

³ *Ibid.*

storm event will be made in consultation with weather forecasting information services after a quantitative precipitation forecast (QPF) has been determined. All efforts will be made to collect wet weather samples from all sites during a single targeted storm event. However, safety or other factors may make it infeasible to collect samples from a given storm event. For example, storm events that will require field crews to collect wet weather samples during holidays and/or weekends may not be sampled due to sample collection or laboratory staffing constraints.

During a typical water year, for a storm to be tracked, the first flush event will have a predicted rainfall of at least 0.25 inches with at least a 70 percent probability of rainfall 24 hours prior to the forecasted time of initial rainfall. Since a significant storm event is based on predicted rainfall, it is recognized that this monitoring may be triggered without 0.25 inches of rainfall actually occurring. In this case, the monitoring event will still qualify as meeting this requirement provided that sufficient sample volume is collected to do all required laboratory analysis. Documentation will be provided showing the predicted rainfall amount. Subsequent storm events must meet the tracking requirements, flow objectives, as well as be separated by a minimum of three days of dry weather. Antecedent conditions will be based on the LA County Department of Public Works (LACDPW) rain gage listed in **Table 33**. The rain gage has been used to define wet and dry weather during TMDL monitoring in the watershed since 2009. Data can be obtained at <http://dpw.lacounty.gov/wrd/Precip/index.cfm> by clicking the ‘See Data’ link in the “Near Real-Time Precipitation Map” section. The web page displays a map showing real-time rainfall totals (in inches) for different rain gages. Although the default precipitation period is 24 hours, the user can view rainfall totals over different durations. Data from the rain gages is updated every 10 minutes.

Table 33. Real-Time Rain Gage Used to Define Weather Conditions for CIMP Monitoring⁽¹⁾

Rainfall Gage	Operator	Gage Type	Latitude	Longitude
University of Southern California (USC) (375)	Los Angeles County Department of Public Works	Manually Observed Non-Mechanical Rain Gage	34.0226	-118.2908

1. Information for the gage can be found at <http://dpw.lacounty.gov/wrd/Precip/alertlist.cfm>.

For the purpose of triggering wet weather sampling preparation, a predicted rainfall of 0.1-0.5 inches in a 6- to 12-hour period would be sufficient to mobilize for wet weather sampling. The sampling crew should prepare to depart at the forecasted time of initial rainfall. The initiation of composite samples should be targeted for collection within 2 hours of local rainfall. The National Weather Service’s weather forecast for the EWMP area can be accessed on-line at <http://www.wrh.noaa.gov/lox/> then click on the location of the EWMP area on the area map. From the forecast page, the link to “Quantitative Precipitation Forecast” provides forecasted precipitation in inches for the next 24 hours, in 3-hour increments for the first 12 hours and in 6-hour increments for the last 12 hours.

Flow conditions will be based on the LACDPW flow gage listed in **Table 34** (or an alternate flow gage if real-time data at the stipulated flow gage cannot be accessed). The flow gage has been used to define flow conditions in TMDLs developed for the ULAR watershed. In addition to the flow gage, field crews may monitor flow at each sampling site during dry weather.

Table 34. Upper Los Angeles River Watershed Representative Flow Gage⁽¹⁾

Flow Gage	Waterbody	Gage Location	Gage Type	Latitude	Longitude
F319-R	LA River Reach 2	900 feet below Wardlow Road	Continuous Water Stage	33.817347	- 118.206268

1. Information for the gage can be found at <http://ladpw.org/wrd/Runoff/design.cfm?facinit=F319-R>.

10.2 Sample Handling

Proper sample handling ensures the samples will comply with the monitoring methods and analytical holding time and provides traceable documentation throughout the history of the sample.

10.2.1 Documentation Procedures

The ULARWMAG is responsible for ensuring that each field sampling team adheres to proper custody and documentation procedures. Field log sheets documenting sample collection and other monitoring activities for each site will be bound in a separate master logbook for each event or saved in an event specific electronic file. Field personnel have the following responsibilities:

1. Keep an accurate written record of sample collection activities on the field log sheets.
2. Ensure that all field log sheet entries are legible and contain accurate and inclusive documentation of all field activities.
3. Note errors or changes using a single line to cross out the entry and date and initial the change.
4. Ensure that a label is affixed to each sample collected and that the labels uniquely identify samples with a sample ID, site ID, date and time of sample collection and the sampling crew initials.
5. Complete the chain of custody forms accurately and legibly.

10.2.2 Field Documentation/Field Log

Field crews will keep a field log book or electronic file for each sampling event that contains calibration documentation, field documentation for each site, and appropriate contact information. The following items should be recorded for each sampling event:

- Monitoring station location (Station ID);
- Date and time(s) of sample collection;
- Name(s) of sampling personnel;
- Sample collection depth;
- Sample ID numbers and unique IDs for any replicate or blank samples;
- QC sample type (if appropriate);
- Requested analyses (specific parameters or method references);
- Sample type (e.g., grab or composite);
- The results of field measurements (e.g., flow, temperature, dissolved oxygen, pH,

- conductivity, turbidity) and the time that measurements were made;
- Qualitative descriptions of relevant water conditions (e.g., water color, flow level, clarity) or weather (e.g., wind, rain) at the time of sample collection;
- Trash observations (presence/absence);
- A description of any unusual occurrences associated with the sampling event, particularly those that may affect sample or data quality.

The field log will be scanned into a PDF within one week of the conclusion of each sampling event. Alternatively, all measurements could be collected on an electronic device such as laptop or tablet computer. **Appendix 1** contains an example of the field log sheet.

10.2.3 Sample Handling and Shipment

The field crews will have custody of samples during each monitoring event. Chain-of-custody (COC) forms will accompany all samples during shipment to contract laboratories to identify the shipment contents. All water quality samples will be transported to the analytical laboratory by the field crew or by courier. The original COC form will accompany the shipment, and a signed copy of the COC form will be sent, typically via fax, by the laboratory to the field crew to be retained in the project file.

While in the field, samples will be stored on ice in an insulated container. Samples that must be shipped to the laboratory must be examined to ensure that container lids are tight and placed on ice to maintain the appropriate temperature. The ice packed with samples must be approximately 2 inches deep at the top and bottom of the cooler, and must contact each sample to maintain temperature. The original COC form(s) will be double-bagged in re-sealable plastic bags and either taped to the outside of the cooler or to the inside lid. Samples must be shipped to the contract laboratory according to transportation standards. The method(s) of shipment, courier name, and other pertinent information should be entered in the “Received By” or “Remarks” section of the COC form.

Coolers must be sealed with packing tape before shipping, unless transported by field or lab personnel, and must not leak. It is assumed that samples in tape-sealed ice chests are secure whether being transported by common carrier or by commercial package delivery. The laboratory’s sample receiving department will examine the shipment of samples for correct documentation, proper preservation and compliance with holding times. The following procedures are used to prevent bottle breakage and cross-contamination:

- Bubble wrap or foam pouches are used to keep glass bottles from contacting one another to prevent breakage, re-sealable bags will be used if available.
- All samples are transported inside hard plastic coolers or other contamination-free shipping containers.
- If arrangements are not made in advance, the laboratory’s sample receiving personnel must be notified prior to sample shipment.

All samples remaining after successful completion of analyses will be disposed of properly. It is the responsibility of the personnel of each analytical laboratory to ensure that all applicable regulations are followed in the disposal of samples or related chemicals. Samples will be stored

and transported as noted in **Table 28**. Samples not analyzed locally will be sent on the same day that the sample collection process is completed, if possible. Samples will be delivered to the appropriate laboratory as will be indicated in **Table 35**. Note that due to procurement procedures, the analytical laboratories have not been identified at this time. Information for all laboratories will be added to this table following their selection and upon CIMP update. Appropriate contacts will be listed along with lab certification information in **Table 35**.

Table 35. Information on Laboratories Conducting Analysis for the ULARWMAG CIMP

Laboratory ⁽¹⁾	General Category of Analysis	Shipping Method	Contact	Phone	Address	Lab Certification No. & Expiration Date ⁽²⁾

1. Information for all laboratories will be added to this table following their selection and upon CIMP update.
2. Lab certifications are renewed on an annual basis.

10.2.4 Chain-of Custody Forms

Sample custody procedures provide a mechanism for documenting information related to sample collection and handling. Sample custody must be traceable from the time of sample collection until results are reported. A sample is considered under custody if:

- It is in actual possession.
- It is in view after in physical possession.
- It is placed in a secure area (accessible by or under the scrutiny of authorized personnel only after in possession).

A COC form must be completed after sample collection and prior to sample shipment or release. The COC form, sample labels, and field documentation will be cross-checked to verify sample identification, type of analyses, number of containers, sample volume, preservatives, and type of containers. A complete COC form is to accompany the transfer of samples to the analyzing laboratory. A typical COC form is presented in **Appendix 1**.

10.2.5 Laboratory Custody Procedures

Laboratories will follow sample custody procedures as outlined in the laboratory’s QA Manual. A copy of each contract laboratory’s QA Manual should be available at the laboratory upon request. Laboratories shall maintain custody logs sufficient to track each sample received and to analyze or preserve each sample within specified holding times. The following sample control activities must be conducted at the laboratory:

- Initial sample login and verification of samples received with the COC form;
- Document any discrepancies noted during login on the COC;
- Initiate internal laboratory custody procedures;
- Verify sample preservation (e.g., temperature);

- Notify the ULARWMAG if any problems or discrepancies are identified; and,
- Perform proper sample storage protocols, including daily refrigerator temperature monitoring and sample security.

Laboratories shall maintain records to document that the above procedures are followed. With the exception of microbiological samples, once samples have been analyzed, samples will be stored at the laboratory for at least 30 days. After this period, samples may be disposed of properly.

10.3 Field Protocols

Briefly, the key aspects of quality control associated with field protocols for sample collection for eventual chemical, microbiological, and toxicological analyses are as follows:

1. Field personnel will be thoroughly trained in the proper use of sample collection gear and will be able to distinguish acceptable versus unacceptable water samples in accordance with pre-established criteria.
2. Field personnel will be thoroughly trained to recognize and avoid potential sources of sample contamination (e.g., engine exhaust, ice used for cooling, touching the inner surfaces the sample bottle or cap).
3. Sampling gear and utensils which come in direct contact with the sample will be made of non-contaminating materials (e.g., borosilicate glass, high-quality stainless steel and/or Teflon™, according to protocol) and will be thoroughly cleaned between sampling stations according to appropriate cleaning protocol.
4. Sample containers will be of the recommended type and will be free of contaminants (i.e., pre-cleaned and/or sterile).
5. Conditions for sample collection, preservation, and holding times will be followed.

Field crews will be comprised of two persons per crew, minimum. For safety reasons, sampling will occur during daylight hours, when possible. Sampling on weekends and holidays will also be avoided. Other constraints on sampling events include, but are not limited to, lab closures and toxicity testing organism availability. Sampling events should proceed in the following manner:

1. Before leaving the sampling crew base of operations, confirm number and type of sample containers as well as the complete equipment list.
2. Proceed to the first sampling site.
3. Fill-out the general information on the field log sheet.
4. Collect the environmental and quality assurance/quality control (QA/QC) samples indicated on the event summary sheet and store samples appropriately. Using the field log sheet, confirm that all appropriate containers were filled.
5. Collect field measurements and observations, and record these on the field log sheet.
6. Repeat the procedures in steps 3, 4, and 5 for each of the remaining sampling sites.
7. Complete the COC forms using the information on the field log sheets.
8. After sample collection is completed, deliver and/or ship samples to appropriate laboratory.

10.4 Sample Collection

All samples will be collected in a manner appropriate for the specific analytical methods to be used. The proper sampling techniques, outlined in this section, will ensure that the collected samples are representative of the waterbodies sampled. Should field crews feel that it is unsafe to collect samples for any reason, the field crews **SHOULD NOT COLLECT** a sample and note on the field log that the sample was not collected, why the sample was not collected, and provide photo documentation, if feasible.

10.4.1 Overview of Sampling Techniques

As described below, the method used to collect water samples is dependent on the depth, flow, and sampling location (receiving water, outfall). Nonetheless, in all cases:

1. Throughout each sample collection event, the sampler should exercise aseptic techniques to avoid any contamination (i.e., do not touch the inner surfaces or lip edges of the sample bottle or cap).
2. The sampler should use clean, powder-free, nitrile gloves for each site to prevent contamination.
3. When collecting the sample, the sampler should not breathe, sneeze, or cough in the direction of the container.
4. Gloves should be changed if they are soiled, or if the potential for cross-contamination exists from handling sampling materials or samples.
5. While the sample is collected, the bottle lid shall not be placed on the ground.
6. The sampler should not eat or drink during sample collection.
7. The sampler should not smoke during sample collection.
8. Each person on the field crew should wear clean clothing that is free of dirt, grease, or other substances that could contaminate the sampling apparatus or sample bottles.
9. To the extent practical, sampling should not occur near a running vehicle. Vehicles should not be parked within the immediate sample collection area, even non-running vehicles.
10. When the sample is collected, ample air space should be left in the bottle to facilitate mixing by shaking for lab analysis, unless otherwise required by the method.
11. After the sample is collected and the cap is tightly screwed back on the bottle, the time of sampling should be recorded on the field log sheet.
12. Any QA/QC samples that are collected should be also be noted on the field log sheet and labeled according the convention described in **Section 10.1** of this Attachment.
13. Samples should be stored as previously described.
14. COC forms should be filled out as described in **Section 10.2** of this Attachment and delivered to the appropriate laboratory as soon as feasible to ensure hold times are met.

To prevent contamination of samples, clean metal sampling techniques using USEPA protocols outlined in USEPA Method 1669⁴ will be used throughout all phases of the water sample collection. The protocol for clean metal sampling, based on USEPA Method 1669, is summarized below:

⁴ USEPA. April 1995. *Method 1669: Sampling Ambient Water for Trace Metals at EPA Water Quality Criteria Levels*. EPA 821-R-95-034.

1. Samples are collected in rigorously pre-cleaned sample bottles with any tubing specially processed to clean sampling standards.
2. At least two persons, wearing clean, powder-free nitrile or latex gloves at all times, are required on a sampling crew.
3. One person, referred to as “dirty hands”, opens only the outer bag of all double-bagged sample bottles.
4. The other person, referred to as “clean hands”, reaches into the outer bag, opens the inner bag and removes the clean sample bottle.
5. Clean hands rinses the bottle at least two times by submerging the bottle, removing the bottle lid, filling the bottle approximately one-third full, replacing the bottle lid, gently shaking and then emptying the bottle. Clean hands then collects the sample by submerging the bottle, removing the lid, filling the bottle and replacing the bottle cap while the bottle is still submerged.
6. After the sample is collected, the sample bottle is double-bagged in the opposite order from which it was removed from the same double-bagging.
7. Clean, powder-free gloves are changed whenever something not known to be clean has been touched.

10.4.2 Field Measurements and Observations

Except as identified in the CIMP, field measurements will be recorded and observations made at each sampling site after a sample is collected. Given that some samples will be collected via automated composite samplers it may not be feasible to collect measurements and observations at the same time as sample collection. In these instances in-situ measurement equipment may be utilized or, if necessary, field measurements will be collected from composited samples and noted as such on the field log forms. Field measurements will include the parameters identified in the CIMP for which laboratory analysis is not required. Field monitoring equipment must meet the requirements outlined in **Table 27**. Field measurements for sediment samples shall be collected from within one meter of the sediment. All field measurement results and field observations will be recorded on a field log sheet (or electronic device) similar to the one presented in **Appendix 1** and as described in **Section 10.2** of this Attachment.

Measurements (except for flow) will be attained at approximately mid-stream, mid-depth at the location of greatest flow (if feasible) with a Hydrolab DS4 multi-probe meter, or comparable instrument(s). If at any time the collection of field measurements by wading appears to be unsafe, field crews will not attempt to collect mid-stream, mid-depth measurements. Rather, field measurements will be made either directly from a stable, unobstructed area at the channel edge, or by using a telescoping pole and intermediate container to obtain a sample for field measurements and for filling sample containers. For situations where flows are not sufficiently deep to submerge the probes, an intermediate container will be utilized. The location of field measurements will be documented on the field log sheet.

Flow measurements will be collected as outlined in the following subsections or from automated flow equipment, if available, at freshwater receiving water and non-stormwater outfall monitoring sites. Regardless of measurement technique used, if a staff gage is present the gage

height will be noted. Field crews may not be able to measure flow at several sites during wet weather because of inaccessibility of the site. If this is the case, site inaccessibility will be documented on the field log sheet.

The field sampling crew has the primary responsibility for responding to failures in the sampling or measurement systems. Deviations from established monitoring protocols will be documented in the comment section of the field log sheet and noted in the post event summaries. If monitoring equipment fails, monitoring personnel will report the problem in the notes section of the field log sheet and will not record data values for the variables in question. Broken equipment will be replaced or repaired prior to the next field use. Data collected using faulty equipment will not be used.

10.4.2.1 Velocity Meter Flow Measurements

For sampling sites where water is deep enough (>0.1-foot) a velocity meter will be utilized. For these cases, velocity will be measured at approximately equal increments across the width of the flowing water using a Marsh-McBirney Flo-Mate® velocity meter⁵ or equivalent, which uses an electromagnetic velocity sensor. A “flow pole” will be used to measure the water depth at each measurement point and to properly align the sensor so that the depth of each velocity measurement is approximately equal to 0.6 * total depth, which is representative of the average velocity. The distance between velocity measurements taken across the stream is dependent on the total width. No more than 10% of the flow will pass through any one cross section.

10.4.2.2 Shallow Sheet Flow Measurements

If the depth of flow does not allow for the measurement of flow with a velocity meter (<0.1-foot) a “float” will be used to measure the velocity of the flowing water. The width, depth, velocity, cross section, and corresponding flow rate will be estimated as follows:

- **Sheet flow width:** The width (W) of the flowing water (not the entire part of the channel that is damp) is measured at the “top”, “middle”, and “bottom” of a marked-off distance – generally 10 feet (e.g., for a 10-foot marked-off section, W_{Top} is measured at 0-feet, W_{Mid} is measured at 5 feet, and W_{Bottom} is measured at 10 feet).
- **Sheet flow depth:** The depth of the sheet flow is measured at the top, middle, and bottom of the marked-off distance. Specifically, the depth (D) of the sheet flow is measured at 0%, 25%, 50%, 75%, and 100% of the flowing width (e.g., $D_{50\%}^{Mid}$ is the depth of the water at middle of the section in the middle of the sheet flow) at each of the width measurement locations.
- **Representative cross-section:** Based on the collected depth and width measurements, the representative cross-sectional area across the marked-off sheet flow is approximated as follows:

⁵ For more information, see <http://marsh-mcBirney.com/Products/2000.htm>

Representative Cross Section =

$$\text{Average} \left\{ \left[\frac{W_{Top}}{4} \times \left(\frac{(D_{25\%}^{Top} + D_{0\%}^{Top})}{2} + \frac{(D_{50\%}^{Top} + D_{25\%}^{Top})}{2} + \frac{(D_{75\%}^{Top} + D_{50\%}^{Top})}{2} + \frac{(D_{100\%}^{Top} + D_{75\%}^{Top})}{2} \right) \right], \right. \\ \left. \left[\frac{W_{Mid}}{4} \times \left(\frac{(D_{25\%}^{Mid} + D_{0\%}^{Mid})}{2} + \frac{(D_{50\%}^{Mid} + D_{25\%}^{Mid})}{2} + \frac{(D_{75\%}^{Mid} + D_{50\%}^{Mid})}{2} + \frac{(D_{100\%}^{Mid} + D_{75\%}^{Mid})}{2} \right) \right], \right. \\ \left. \left[\frac{W_{Bottom}}{4} \times \left(\frac{(D_{25\%}^{Bottom} + D_{0\%}^{Bottom})}{2} + \frac{(D_{50\%}^{Bottom} + D_{25\%}^{Bottom})}{2} + \frac{(D_{75\%}^{Bottom} + D_{50\%}^{Bottom})}{2} + \frac{(D_{100\%}^{Bottom} + D_{75\%}^{Bottom})}{2} \right) \right] \right\}$$

- **Sheet flow velocity:** Velocity is calculated based on the amount of time it took a float to travel the marked-off distance (typically 10-feet or more). Floats are normally pieces of leaves, litter, or floatables (suds, etc.). The time it takes the float to travel the marked-off distance is measured at least three times. Then average velocity is calculated as follows:

$$\text{Average Surface Velocity} = \frac{\text{Distance Marked off for Float Measurement}}{\text{Average Time for Float to Travel Marked off Distance}}$$

- **Flow Rate calculation:** For sheet flows, based on the above measurements/estimates, the estimated flow rate, Q, is calculated by:

$$Q = f \times (\text{Representative Cross Section}) \times (\text{Average Surface Velocity})$$

The coefficient f is used to account for friction effects of the channel bottom. That is, the float travels on the water surface, which is the most rapidly-traveling portion of the water column. The average velocity, not the surface velocity, determines the flow rate, and thus f is used to “convert” surface velocity to average velocity. In general, the value of f typically ranges from 0.60 – 0.90 (USGS 1982). Based on flow rate measurements taken during the LA River Bacteria Source Identification Study (CREST 2008) a value of 0.75 will be used for f.

10.4.2.3 Free-flowing outfalls

Some storm drain outfalls are free-flowing, meaning the runoff falls from an elevated outfall into the channel, which allows for collection of the entire flowing stream of water into a container of known volume (e.g., graduated bucket or graduated Ziploc bag). The time it takes to fill the known volume is measured using a stopwatch, and recorded on the field log. The time it takes to fill the container will be measured three times and averaged to ensure that the calculated discharge is representative. In some cases, a small portion of the runoff may flow around or under the container. For each measurement, “percent capture”, or the proportion of flow estimated to enter the bucket, will be recorded. For free-flowing outfalls, the estimated flow rate, Q, is calculated by:

$$Q = \text{Average} \left[\frac{\text{Filled container Volume}}{(\text{Time to Fill Container}) \times (\text{Estimated Capture})} \right]$$

Based on measurements of free-flowing outfalls during the LA River Bacteria Source Identification Study (CREST, 2008), estimated capture typically ranges from 0.75 – 1.0.

10.4.3 Sampling Techniques for the Collection of Water

The following subsections provide details on the various techniques that can be utilized to collect water quality samples. Should field crews feel that it is unsafe to collect samples for any reason, the field crews **SHOULD NOT COLLECT** a sample and note on the field log that the sample was not collected, why the sample was not collected, and provide photo documentation, if feasible.

10.4.3.1 *Direct Submersion*

Where practical, all grab samples will be collected by direct submersion at mid-stream, mid-depth using the following procedures:

1. Follow the standard sampling procedures described in **Section 10.4.1** of this Attachment.
2. Remove the lid, submerge the container to mid-stream/mid-depth, let the container fill and secure the lid. In the case of mercury samples, remove the lid underwater to reduce the potential for contamination from the air.
3. Place the sample on ice.
4. Collect the remaining samples including quality control samples, if required, using the same protocols described above.
5. Follow the sample handling procedures described in **Section 10.2** of this Attachment.

10.4.3.2 *Intermediate Container Technique*

Samples may be collected with the use of a clean intermediate container, if necessary, following the steps listed below. An intermediate container may include a container that is similar in composition to the sample container, a pre-cleaned pitcher made of the same material as the sample container, or a Ziploc bag. An intermediate container should not be reused at a different site without appropriate cleaning.

1. Follow the standard sampling procedures described in **Section 10.4.1** of this Attachment.
2. Submerge the intermediate container to mid-stream/mid-depth (if possible), let the container fill, and quickly transfer the sample into the individual sample container(s) and secure the lid(s).
3. Place the sample(s) on ice.
4. Collect remaining samples including quality control samples, if required, using the same protocols described above.
5. Follow the sample handling procedures described in **Section 10.2** of this Attachment.

Some flows may be too shallow to fill a container without using an intermediate container. When collecting samples from shallow sheet flows it is very important to not scoop up algae, sediment, or other particulate matter on the bottom because such debris is not representative of flowing water. To prevent scooping up such debris either: (1) find a spot where the bottom is relatively clean and allow the sterile intermediate container to fill without scooping; or (2) lay a clean sterile Ziploc® bag on the bottom and collect the water sample from on top of the bag. A fresh Ziploc® bag must be used at each site.

10.4.3.3 Pumping

Samples may be collected with the use of a peristaltic pump and specially cleaned tubing following the steps listed below. Sample tubing should not be reused at a different site without appropriate cleaning.

1. Follow the standard sampling procedures described in **Section 10.4.1** of this Attachment.
2. Attach pre-cleaned tubing into the pump, exercising caution to avoid allowing tubing ends to touch any surface known not to be clean. A separate length of clean tubing must be used at each sample location for which the pump is used.
3. Place one end of the tubing below the surface of the water. To the extent possible, avoid placing the tubing near the bottom so that settled solids are not pumped into the sample container.
4. Hold the other end of the tubing over the opening of the sample container, exercising care not to touch the tubing to the sample container.
5. Pump the necessary sample volume into the sample container and secure the lid.
6. Place the sample on ice.
7. Collect remaining samples including quality control samples, if required, using the same protocols described above.
8. Follow the sample handling procedures described in **Section 10.2** of this Attachment.

10.4.3.4 Autosamplers

Autosamplers are used to characterize the entire flow of a storm in one analysis. They can be programmed to take aliquots at either time- or flow-based specified intervals. As specified in Attachment E of the MRP Part VIII.C, samples shall be collected for the entire storm water discharge if it is less than 24 hours. Before beginning setup in the field, it is recommended to read the manufacturer's instructions. The general steps to set up the autosampler are described below:

1. Connect power source to autosampler computer. This can be in the form of a battery or a power cable.
2. Install pre-cleaned tubing into the pump. To the extent practicable, clean tubing will be used at each site and for each event, in order to minimize contamination. For some stations, it may be more practicable to replace tubing on an annual or every other year basis. In those instances, it would be appropriate to collect equipment blanks prior to sampling events. Tubing that is not newly installed should be flushed with clean water prior to each sampling event.
3. Attach strainer to intake end of the tubing and install in sampling channel.
4. If running flow based composite samples; install flow sensor in sampling channel and connect it to the automatic compositor.
5. Label and install composite bottle(s). If sampler is not refrigerated, then add enough ice to the composite bottle chamber to keep sample cold for the duration of sampling or until such time as ice can be refreshed. Make sure not to contaminate the inside of the composite bottle with any of the ice.
6. Program the autosampler as per the manufacturer's instructions and make sure the autosampler is powered and running before leaving the site.

After the sample collection is completed the following steps must be taken to ensure proper sample handling:

1. Upon returning to the site, check the status of the autosampler and record any errors or missed samples. Note on the field log the time of the last sample, as this will be used for filling out the COCs.
2. Remove the composite bottle and store on ice. If dissolved metals are required, then begin the sample filtration process outlined in the following subsection, within 15 minutes of the last composite sample, unless compositing must occur at another location, in which case the filtration process should occur as soon as possible upon sample compositing.
3. Power down autosampler, unless continuous flow measurements are being collected, and leave sampling site.
4. The composite sample will need to be split into the separate analysis bottles either before being shipped to the laboratory or at the laboratory. This is best done in a clean and weatherproof environment, using clean sampling technique.

10.4.3.5 Dissolved Metals Field Filtration

When feasible, samples for dissolved metals will be filtered in the field.⁶ The following describes an appropriate field filtration method. An alternative or equivalent method may be utilized, if necessary.⁷ A 50mL plastic syringe with a 0.45µm filter attached will be used to collect and filter the dissolved metals sample in the field. The apparatus will either come certified pre-cleaned from the manufacturer and confirmed by the analytical laboratory or be pre-cleaned by and confirmed by the analytical laboratory at least once per year. The apparatus will be double bagged in Ziploc plastic bags.

To collect the sample for dissolved metals, first collect the total metals sample using clean sampling techniques. The dissolved sample will be taken from this container. Immediately prior to collecting the dissolved sample, shake the total metals sample. To collect the dissolved metals sample using clean sampling techniques, remove the syringe from the bag and place the tip of the syringe into the bottle containing the total metals sample and draw up 50 mL of sample into the syringe. Next, remove the filter from the zip-lock bag and screw it tightly into the tip of the syringe. Then put the tip of the syringe with the filter into the clean dissolved metals container and push the sample through the filter taking care not to touch the inside surface of the sample container with the apparatus. The sample volume needs to be a minimum of 20 mL. If the filter becomes clogged prior to generating 20 mL of sample, remove and dispose of the used filter and replace it with a new clean filter (using the clean sampling techniques). Continue to filter the sample. When 20 mL has been collected, cap the sample bottle tightly and store on ice for delivery to the laboratory.

⁶ If the field filtration for dissolved metals is not practical or feasible the filtration and preservation of the sample in accordance with the applicable method should be done as soon as practical upon delivery to the laboratory.

⁷ Alternative methods should be considered (especially when more volume is required for lab analysis); for example, such as filtering 1 or 2 Liters by passing sample through 0.45 um filter using peristaltic pump equipped with clean tubing.

10.4.4 Receiving Water Sample Collection

A grab sample is a discrete individual sample. A composite sample is a mixture of samples collected over a period of time either as time or flow weighted. A time-weighted composite is created by mixing multiple aliquots collected at specified time intervals. A flow-weighted composite is created by mixing multiple aliquots collected at equal intervals but where the volume of the aliquot is based on flow rate. Generally, grab samples will be collected during dry weather and composite samples will be collected during wet weather. Should field crews feel that it is unsafe to collect samples for any reason, the field crews **SHOULD NOT COLLECT** a sample and note on the field log that the sample was not collected, the reason the sample was not collected, and provide photo documentation, if feasible.

Grab samples will be used for dry weather sampling events, because the composition of the receiving water will change less over time; and thus, the grab sample can sufficiently characterize the receiving water. Grab samples will be collected as described in **Section 10.4.3** of this Attachment. Monitoring site configuration and consideration of safety will dictate grab sample collection technique. The potential exists for monitoring sites to lack discernable flow. Except in the case of lakes, the lack of discernable flow may generate unrepresentative data. To address the potential confounding interference that can occur under such conditions, sites sampled should be assessed for the following conditions and sampled or not sampled accordingly:

- Pools of water with no flow or no visible connection to another surface water body should not be sampled. The field log should be completed for non-water quality data (including date and time of visit) and the site condition should be photo-documented.
- Flowing water (i.e., based on visual observations, flow measurements, and a photo-documented assessment of conditions immediately upstream and downstream of the sampling site) site should be sampled.

Wet weather samples will generally be collected as either time- or flow-weighted composites. Grab samples may be utilized to collect wet weather sampling in certain situations, which may include, but are not limited to, situations where it is unsafe to collect composite samples or to perform investigative monitoring where composite sampling or installation of an autosampler may not be warranted. For safety purposes, when wet weather grab sampling is conducted, samples may be taken from slightly upstream or downstream of the designated monitoring location.

It is the combined responsibility of all members of the sampling crew to determine if the performance requirements of the specific sampling method have been met, and to collect additional samples if required. If the performance requirements outlined above or documented in sampling protocols are not met, the sample will be re-collected. If contamination of the sample container is suspected, a fresh sample container will be used. The ULARWMAG will be contacted if at any time the sampling crew has questions about procedures or issues based on site-specific conditions.

10.4.5 Stormwater Outfall Sample Collection

Stormwater outfalls will be monitored with similar methods as discussed in **Section 10.4.4** of this Attachment. Sampling will not be undertaken if the outfalls are not flowing or if conditions exist where the receiving water is back-flowing into the outfall. It is the combined responsibility of all members of the sampling crew to determine if the performance requirements of the specific sampling method have been met, and to collect additional samples if required. If the performance requirements outlined above or documented in sampling protocols are not met, the sample will be re-collected. If contamination of the sample container is suspected, a fresh sample container will be used. The ULARWMAG will be contacted if at any time the sampling crew has questions about procedures or issues based on site-specific conditions.

10.4.6 Non-Stormwater Outfall Screening Surveys and Sample Collection

The outfall screening process is designed to identify outfalls that have significant non-stormwater (NSW) discharges. The collection of water quality data will support the determination of significant NSW discharges as well as to characterize dry weather loading.

10.4.6.1 Preparation for Outfall Surveys

Preparation for outfall surveys includes preparation of field equipment, placing bottle orders, and contacting the necessary personnel regarding site access and schedule. The following steps should be completed two weeks prior to each outfall survey:

1. Check weather reports and LACDPW rain gage to ensure that antecedent dry weather conditions are suitable.
2. Contact appropriate Flood Maintenance Division personnel from LACDPW to notify them of dates and times of any activities in flood control channels.
3. Contact laboratories to order bottles and to coordinate sample pick-ups.
4. Confirm scheduled sampling date with field crews.
5. Set-up sampling day itinerary including sample drop-offs and pick-ups.
6. Compile field equipment.
7. Prepare sample labels.
8. Prepare event summaries to indicate the type of field measurements, field observations, and samples to be taken at each of the outfalls.
9. Prepare COCs.
10. Charge the batteries of field tablets (if used).

10.4.6.2 Non-Stormwater Sample Collection

Water quality samples will be collected consistent with the dry weather requirements outlined in the receiving water monitoring section using the direct submersion, intermediate container, shallow sheet flow, or pumping methods described in **Section 10.4.3** of this Attachment. As described in Section 5 of the CIMP, *E. coli* was identified as the primary characteristic for determining significant NSW discharges. As noted on page 5 of Attachment E of the MS4 Permit, grab samples shall be taken for constituents that are required to be collected as such (e.g., pathogen indicator bacteria). Because of this and for consistency with the dry weather sampling approach described in **Section 10.4.4**, non-stormwater samples will be collected as grab samples.

10.4.7 Stormborne Sediment Sampling and Analysis

The Echo Park Lake PCBs and Organochlorine Pesticide TMDLs and the Harbors Toxics TMDLs include requirements for the analysis of water quality samples to assess the contribution of certain organic pollutants associated with bulk sediment (**Table 36**).

Table 36. Categories of Constituents for Assessing Sediment Concentrations in Water for the Echo Park Lake PCBs and Organochlorine Pesticide TMDLs and the Harbors Toxics TMDLs

General Category of Constituent	Harbors Toxics TMDLs	Echo Park Lake PCBs and Organochlorine Pesticides TMDLs
Metals ⁽¹⁾	X	
DDTs ⁽²⁾	X	X
Chlordanes ⁽²⁾	X	X
Dieldrin		X
PCBs ⁽²⁾	X	X
PAHs ⁽²⁾	X	

1. Metals include copper, lead, and zinc.
2. See **Table 25** for a list of individual constituents in each category.

Most of the organochlorine (OC) pesticides and PCBs and many of the PAHs tend to strongly associate with sediment and organic material. These constituents commonly have octanol/water partition coefficients ($\log K_{ow}$) that are greater than six, elevated soil/water partition coefficients ($\log K_d$) and elevated soil adsorption coefficients ($\log K_{oc}$). The lighter weight PAHs such as naphthalene, acenaphthene and acenaphthylene tend to be more soluble in water and volatile. Concentrations of OC pesticides, PCBs, and PAHs are often below or are very close to the limits of detection for conventional analytical methods used for analyzing water samples. Although collection and filtration of high volumes of stormwater will allow improved quantification of these constituents, it also introduces substantial potential for introduction of errors.

A number of studies have been performed to directly measure the concentration of contaminants associated with suspended solids but there are no standardized procedures established for this type of testing. Use of filtration methods in combination with conventional analytical methods requires collection of extremely large volumes of stormwater and challenging filtration processes. Use of conventional analytical methods for analysis of the filtered sediment is then expected to require at least 5 grams (dry weight) of sediment (typically 10 grams dry weight is preferred by laboratories) for each of the groups of analytes (metals, OC pesticides, PCBs and PAHs) in order to achieve detection limits necessary to quantify loads. In addition, the direct impacts of filtering samples with high sediment content are not well understood. Efforts by the City of Los Angeles and Los Angeles County in the Ballona Creek and Marina del Rey watersheds, respectively, have demonstrated the challenges associated with collecting and analyzing suspended sediments. Assuming samples contain sediment at an average TSS concentration of 100 mg/L and that all sediment could be recovered, analyses might require as much as 50 liters for each test method (total of 200 liters). An ongoing special study is underway in Marina del Rey to evaluate various methods for capturing sufficient sediment to conduct analysis. In Ballona Creek, the City of Los Angeles has been successful in collecting sufficient

volumes of sediment over the course of a year to conduct the analysis. This allows for the quantification of annual loading; however, it does not allow for an evaluation of concentrations and loads under various storm conditions. Although use of lower sediment volumes may be possible, both detection limits and quality control measures might be impacted. In Ballona Creek, duplicate and quality control analysis have been limited to the available sediment, resulting in situations where either certain target constituents or quality control analysis are not completed during the pilot study.

An alternative approach for assessing the loads of the constituents of interest will be utilized in this CIMP to substantially reduce the amount of sample needing to be handled and potential for introduction of error. This approach will utilize High Resolution Mass Spectrometry (HRMS) to analyze for OC pesticides (USEPA 1699), PCBs (USEPA 1668) and PAHs (CARB). HRMS analyses are quantified by isotope dilution techniques. Conventional methods utilized to analyze water samples for most metals of interest are sufficiently sensitive to allow for the assessment of concentrations on suspended sediments. During the first three years, analyses will be conducted on whole water samples. These test methods provide detection limits that are roughly 100 times more sensitive than conventional analytical methods. In addition, these extremely low detection limits can be achieved with as little as 3-6 liters of stormwater. Similar approaches have been used by the San Francisco Estuary Institute (SFEI) staff (Gilbreath, Pearce and McKee, 2012) to measure the performance of a rain garden. Autosamplers were used to collect stormwater influent and treated effluent to assess removal efficiency for pesticides, PCBs, mercury, and copper subject to TMDLs. HRMS was used to quantify PCB removal. HRMS methods are also being used in Virginia to assist in identification of sources of PCBs in MS4 and industrial stormwater discharges (Gilinsky, 2009).

Use of this approach is expected to greatly enhance the ability to consistently obtain appropriate samples for measuring and comparing loads of constituents of interest associated with each sampling event. This will assure that all key toxics can be quantified at levels suitable for estimation of mass loads. Due to relatively low levels of sediment in stormwater, efforts in Los Angeles County related to TMDL monitoring of suspended sediments have often led to the need to composite sediments collected over multiple storm events. The approach contained herein provides the opportunity to quantify concentrations, and therefore loads, for each stormwater sampling event.

For purposes of load calculations, it would be assumed that 100% of OC pesticides, PCBs and PAHs were associated with suspended solids. Separate analyses of TSS/SSC would be used to normalize the data. After three years (approximately four to six storm events) the data will be reevaluated to assess whether direct analysis of the filtered suspended sediments are necessary to improve load assessments. If deemed necessary, a modified approach will be evaluated for analysis of suspended sediments. It is currently not clear whether direct measurement of the target toxics in suspended sediments will result in any significant improvements in our ability to assess loads. In fact, collecting, transporting and processing the high volumes of stormwater necessary for this approach may result in a decrease in our ability to obtain useful data and will likely result in a decrease in our ability to assess pollutant loads.

Analysis of trace metals will be conducted based upon measured concentrations of dissolved and trace metals in routine monitoring at the downstream receiving water site. Existing detection limits for trace metals are considered suitable for calculation of concentrations in suspended solids. The concentration of trace metals associated with the particulate fraction will be calculated as:

$$C_P = C_T - C_D$$

where C_T = Concentration of total recoverable metals

C_D = Concentration of dissolved fraction

C_P = Concentration of the particulate fraction

USEPA's guidance document for development of metals translators (EPA, 1996) uses the same approach for calculation of the trace metals in the particulate fraction.

10.4.7.1 *Sampling and Analytical Procedures*

Stormwater samples for the Echo Park Lake PCBs and OC Pesticide TMDLs and the Harbors Toxics TMDLs will be collected using autosamplers as described in **Section 10.4.3.4**. Based on TSS measurements at three mass emission sites in LA County (**Table 37**), use of a TSS concentration of 100 mg/L is expected to provide a conservative basis for estimating reporting limits for OC pesticides, PCBs, and PAHs in suspended sediments based upon 2-liter samples. However, three liters of storm water will be provided for each organic analytical suite for a total of nine liters. An accurate measure of suspended sediments is critical to this sampling approach. TSS will be analyzed; however, SSC will be used as the standard for calculating the concentrations of target constituents in suspended sediments and total loads.

Table 37. Summary of Median TSS Measurements (mg/L) at Three Mass Emission Monitoring Sites in Los Angeles County

Waterbody	LA County Monitoring Site ID	Median
Los Angeles River	S10	143
San Gabriel River	S14	113
Ballona Creek	S01	158

Since detection limits will depend upon the concentration of suspended sediment in the sample, the laboratory analyzing the suspended sediment concentrations will be asked to provide a rush analysis to provide information that can be used to direct processing of the samples for the organic compounds. Processing of sample waters provided to the laboratory will depend upon the results of the SSC analysis.

- If TSS/SSC are less than 150 mg/L, an additional liter of water will be extracted for each subsequent HRMS analysis. If TSS concentrations are between 150 and 200 mg/L, one of the additional liter samples may be used to increase the volume of sample water for just PAHs or the two additional liters may be used as a field duplicate for one of the analyses.
- If TSS concentrations are greater than 200 mg/L, two of the three additional liters may be

used as a field duplicate for one analysis. If available, the additional water provided in 2.5 L containers will also be considered for use as field replicates.

- If the initial TSS sample indicates that sediment content is less than 50 mg/L, additional measures will be taken to improve PAH reporting limits with respect to suspended sediment loads. This would include use of extra sample water to bring up the total sample volume (up to a maximum of 4 liters) or reduction the final extract volume.
- Given adequate sample volumes and normal levels of suspended sediment, a field duplicate will be analyzed for each analysis.

Target reporting limits (**Table 38** and **Table 39**) were established based upon bed sediment reporting limits listed in the *Coordinated Compliance and Reporting Plan for the Greater Los Angeles and Long Beach Harbor Waters* (Anchor QEA, 2013). **Table 38** and **Table 39** provide a summary of the detection limits attainable in water samples using HRMS analytical methods. Estimated detection limits are provided for concentrations of the target constituents in suspended sediments given the assumption that 2-liter sample volumes will be used for each test suspended sediment content of the water sample is 100 mg/L and that 100 percent of the target constituents are associated with the suspended sediment. This provides a conservative assumption with respect to evaluating the potential impacts of concentrations of OC pesticides, PCBs, and PAHs in suspended sediment on concentrations in bed sediment. Additionally, **Table 38** and **Table 39** present relevant TMDL targets and reporting limits suggested in the SWAMP QAPP (SWRCB, 2008) and the SQO Technical Support Manual (SCCWRP, 2009). **Table 40** examines the possible limitations of this approach if trace metal concentrations are extremely low, approaching detection limits. The following summarizes a comparison between the estimated detection limits for OC pesticides, PCBs, and PAHs in the suspended sediments to target reporting limits:

- For OC pesticides (**Table 38**), estimated detection limits in the suspended sediment are at or below TMDL targets limits for bed sediments, except for dieldrin. The dieldrin estimated detection limit is above the lowest TMDL target, but not the remaining TMDL targets, and is below observed concentrations reported in the TMDL staff reports. Additionally, estimated detection limits in the suspended sediment are below target bed sediment reporting limits for this CIMP and target reporting limits presented in the SWAMP QAPP (SWRCB, 2008) and the SQO Technical Support Manual (SCCWRP, 2009), except for dieldrin. Dieldrin is above the bed sediment reporting limit in this CIMP, but below target reporting limits presented in the SWAMP QAPP (SWRCB, 2008) and the SQO Technical Support Manual (SCCWRP, 2009).
- For PCBs (**Table 38**), estimated detection limits in the suspended sediment are below TMDL targets limits for bed sediments. Additionally, estimated detection limits in the suspended sediment are at or below target bed sediment reporting limits for this CIMP and below target reporting limits presented in the SWAMP QAPP (SWRCB, 2008) and the SQO Technical Support Manual (SCCWRP, 2009).
- For PAHs (**Table 39**), estimated detection limits in the suspended sediment are below TMDL targets limits for bed sediments. Most individual PAH compounds would be expected to be detectable in the suspended sediment at concentrations about 2.5 times greater than the target bed sediment reporting limits for this CIMP and the target reporting limits presented in the SWAMP QAPP (SWRCB, 2008). Approximately half of the

individual PAH compounds are above the target reporting limits presented in the SQO Technical Support Manual (SCCWRP, 2009), while the other half are below. Two compounds, naphthalene and phenanthrene, would have detection limits roughly 6 times the target bed sediment reporting limits for this CIMP. Naphthalene is an extremely light weight PAH that is not considered a major analyte of concern in storm water.

- **Table 40** summarizes the reporting limits applicable to total recoverable metals. Estimated equivalent concentrations in suspended solids are very conservatively estimated based upon 100 percent of the metals being associated with suspended particulates as measured values approach project detection limits. In reality, this is not a likely condition. When concentrations of total recoverable metals approach the very low detection limits used in this program, sediment loads will also be extremely low and the concentrations of metals in the dissolved phase will become a more significant fraction of the total metals concentrations.

10.4.7.2 Quality Control Measures

In addition to the quality control measures described in **Section 11**, quality control measures for all HRMS analyses will include field equipment blanks to assess background contamination due to the field equipment and sample handling. One field equipment blank will be analyzed from one set of field equipment during each sampling site during the first year. Data will be evaluated at the end of the year to determine if field equipment blanks should be reduced to one per season. For the field blank, two liters of HPLC grade water provided by the laboratory will be pumped through the entire autosampler and intake hose for each analytical test (OC pesticides, PCBs and PAHs). The blank water will be pumped into precleaned sample containers and refrigerated until the stormwater sampling is completed. If the storm does not occur immediately after blanking, the equipment blank will be transmitted under COC to the laboratory in order to meet the requirement for extraction of aqueous samples within 7 days of collection. Extracts will be held until stormwater samples are received unless storm does not develop within a period of 30 days after extraction (samples are required to be analyzed within 40 days of extraction). If a successful storm event is monitored immediately after the equipment blank is taken, the equipment blank and stormwater samples will be submitted to the laboratory together. Given adequate sample volumes, field duplicates will also be analyzed to assess variability associated with the sampling and subsampling processes.

Laboratory quality control measures will include analysis of method blanks, initial calibrations, analysis of Ongoing Precision and Recovery (OPR) samples and use of labeled compounds to assess recoveries and matrix interferences. Method blanks will be based upon processing of laboratory water volumes identical to those used for the field samples. Initial calibrations are run periodically but daily calibration checks are conducted to verify stability of the calibration. OPR tests will be conducted with each batch of samples. OPR samples are blanks spiked with labeled isotopes that are used to monitor continued performance of the test. Labeled isotopes are added to each field sample and analyzed to measure recovery in the sample matrix. Estimated Detection Limits (EDLs) will be calculated for each analyte associated with each field sample. For each analyte 'x', the EDL is calculated by the following formula:

$$EDL_x = 2.5 * \frac{(Na)*(Qis)*(Rah)}{(Ais)*(RRF)*(wv)}$$

Where: Na = Analyte peak to peak noise height.
Qis = Concentration of internal standard.
Rah = Area of Height Ratio
Ais = Area of internal standard
RRF = initial calibration average relative response factor for the congener of interest.
wv = sample weight/volume.
2.5 = Minimum signal to noise ratio.

10.4.7.3 Summary

In summary, all target reporting limits for all metals and all but one of the targeted organic compound are below or comparable to relevant TMDL targets and the overwhelming majority are below bed sediment reporting limits identified in this CIMP and the SWAMP QAPP (SWRCB, 2008) and SQO Technical Support Manual (SCCWRP, 2009). Overall, the proposed approach based upon analyzing whole water samples to estimate concentrations of target pollutants meets the overall objectives of the program while also enhancing the chances of successfully monitoring multiple storm events and provide data necessary to evaluate relative loads from multiple storms each year. The proposed methods are also expected to allow incorporation of quality control measures necessary to evaluate potential source of contamination and variability that might be attributable to both the sampling and analytical processes.

Table 38. Recommended Methods, Estimated Detection Limits, Target Reporting Limits, and Relevant TMDL Targets for Organochlorine Pesticides and Total PCBs

Constituent and Analytical Method	Detection Limits Associated with Suspended Sediments		Reporting Limits Associated with Bed Sediment Monitoring			Relevant TMDL Targets		
	Water Detection Limit ⁽¹⁾	Equivalent Suspended Sediment Detection Limit ⁽²⁾	ULAR CIMP Target Bed Sediment Reporting Limits	SWAMP QAPP (2008) Reporting Limit	SQO Technical Support Manual (2009) Reporting Limit	Harbors Toxics TMDL Sediment Target (Indirect Effects)	Harbors Toxics TMDL Sediment Target (Direct Effects)	Echo Park Lake Sediment Target (Indirect Effects)
	pg/L	ng/g – dry wt	ng/g – dry wt			ng/g – dry wt		
Chlordane Compounds (EPA 1699)								
alpha-Chlordane	40	0.4	0.5	1	0.5	1.3 (Total Chlordane)	0.5 (Total Chlordane)	2.1 (Total Chlordane)
gamma-Chlordane	40	0.4	0.5	1	0.54			
Oxychlordane	40	0.4	0.5	1	NA			
trans-Nonachlor	40	0.4	0.5	1	4.6			
cis-Nonachlor	40	0.4	0.5	2	NA			
Other OC Pesticides (EPA 1699)								
2,4'-DDD	40	0.4	0.5	2	0.5	1.9 (Total DDT)	1.58 (Total DDT)	NA
2,4'-DDE	80	0.8	0.5	2	0.5			
2,4'-DDT	80	0.8	0.5	3	0.5			
4,4'-DDD	40	0.4	0.5	2	0.5			
4,4'-DDE	80	0.8	0.5	2	0.5			
4,4'-DDT	80	0.8	0.5	5	0.5			
Total DDT	80	0.8	---	---	0.5			
Dieldrin	40	0.4	0.02	2	2.7	NA	0.02	0.8
Total PCBs (EPA 1668)	5-20	0.05-0.2	0.2	0.2	3.0	3.2	22.7	1.77

NA – Not applicable

1. Water EDLs based upon 2 liters of water.
2. Suspended Sediment detection limits based upon estimate of 100 mg/L suspended solids.

Table 39. Recommended Method, Estimated Detection Limits, Target Reporting Limits, and Relevant TMDL Targets for PAHs

Constituent	Detection Limits Associated with Suspended Sediments		Reporting Limits Associated with Bed Sediment Monitoring			Relevant TMDL Targets
	Water Detection Limit ⁽¹⁾	Equivalent Suspended Sediment Detection Limit ⁽²⁾	ULAR CIMP Target Bed Sediment Reporting Limits	SWAMP QAPP (2008) Reporting Limit	SQO Technical Support Manual (2009) Reporting Limit	Harbors Toxics TMDL Sediment Target (Direct Effects)
	pg/L	ng/g – dry wt	ng/g – dry wt			ng/g – dry wt
1-Methylnaphthalene	5	50	20	20	20	552 (Low Weight) ⁽³⁾ 1700 (High Weight) ⁽³⁾ 4700 (Total PAHs)
1-Methylphenanthrene	5	50	20	20	20	
2-Methylnaphthalene	5	50	20	20	20	
2,6-Dimethylnaphthalene	5	50	20	20	20	
Acenaphthene	5	50	20	20	20	
Anthracene	5	50	20	20	20	
Benzo(a)anthracene	5	50	20	20	80	
Benzo(a)pyrene	5	50	20	20	80	
Benzo(e)pyrene	5	50	20	20	80	
Biphenyl	5	50	20	20	20	
Chrysene	5	50	20	20	80	
Dibenz(a,h)anthracene	5	50	20	20	80	
Fluoranthene	5	50	20	20	80	
Fluorene	5	50	20	20	20	
Naphthalene	12.5	125	20	20	20	
Perylene	5	50	20	20	80	
Phenanthrene	12.5	125	20	20	20	
Pyrene	5	50	20	20	80	

NA – Not applicable

1. Water EDLs based upon 2 liters of water and CARB 429m. If the SSC is low, either an additional liter of water can be extracted to decrease the detection limit by 1/3 or the final extract volume can be reduced. Depending on sample characteristics, the extract volume can be reduced to as little as 50-100 µL which would drop EDLs by a factor of 0.1 to 0.2 times the listed EDLs.
2. Suspended Sediment MLs based upon estimate of 100 mg/L suspended solids.
3. *Low Molecular Weight PAHs* Low weight PAHs include Acenaphthene, Anthracene, Phenanthrene, Biphenyl, Naphthalene, 2,6-dimethylnaphthalene, Fluorene, 1-methylnaphthalene, 2-methylnaphthalene, 1-methylphenanthrene, *High Molecular Weight PAHs*: Benzo(a)anthracene, Benzo(a)pyrene, Benzo(e)pyrene, Chrysene, Dibenz(a,h)anthracene, Fluoranthene, Perylene, Pyrene.

Table 40. Estimated Detection Limits, Target Reporting Limits, and Relevant TMDL Targets for Metals

Constituent	Detection Limits Associated with Suspended Sediments		Reporting Limits Associated with Bed Sediment Monitoring			Relevant TMDL Targets
	Water Detection Limit ⁽¹⁾	Equivalent Suspended Sediment Detection Limit ⁽²⁾	ULAR CIMP Target Bed Sediment Reporting Limits	SWAMP QAPP (2008) Reporting Limit	SQO Technical Support Manual (2009) Reporting Limit	Harbors Toxics TMDL Sediment Target (Direct Effects)
	µg/L	ng/g – dry wt	ng/g – dry wt			ng/g – dry wt
Copper	0.50	5.0	0.01	0.01	52.8	34
Lead	0.50	5.0	0.01	0.01	25	46.7
Zinc	1	10	0.1	0.01	60	150

1. Suspended Sediment EDLs based upon estimate of 100 mg/L suspended solids.

10.4.8 Sediment Sample Collection in Lakes

The top layer of sediment will be sampled from the bottom of the lake using an Eckman dredge or a similar device. While on a boat, the field crew will drop the Eckman dredge to the bottom of the lake and obtain a sample. Using a pre-cleaned stainless steel trowel, the field crew will scoop the top two to three centimeters of the sample and place it in a clean polyethylene bag. This procedure will be repeated, carefully to as not sample the exact same location, and the final composited sample will be mixed and placed into the appropriate sample jars.

10.4.9 Bioaccumulation Sample Collection

Bioaccumulation sampling will be used to monitor trends in the concentration of contaminants in the tissues of aquatic organisms. This will be conducted in order to assess both ecological and human health concerns and to see if the trends or patterns of contaminant concentrations mirror those observed from the sediment analyses. Human health concerns will be assessed by sampling the tissues from fish species that are commonly taken for consumption by sport fisherman.

Fish sampling protocols shall be conducted in accordance with the California Office of Environmental Health Hazard Assessment's (OEHHA) General Protocol for Sport Fish Sampling and Analysis. Fish may be analyzed, as individuals (preferred) or as composites (secondary). During each survey, the goal will be to collect at least nine fish per targeted species that are of legal size.⁸ If fish are analyzed as composite samples, each composite sample shall include a minimum of three fish, with up to five fish per sample preferred, especially if smaller fish are caught (OEHHA, 2005). All fish composite samples must follow OEHHA's "75 percent rule," where the length of the smallest fish should be at least 75% of the length of the largest fish of a species in a composite sample.

Fish sampling techniques may vary due to season, weather, flow rate, target species, etc. Sport fish may be taken by hook and line or seine. Sampling gear may include electrofishing boats, backpack electrofishers, seine nets, gill nets, trap nets, hook and line, or other equipment as required. Reasonable attempts will be made to collect two to three species of sport fish; but, if sport fish cannot be obtained, whatever species of fish, if any, that can be obtained will be collected and analyzed. However, data collected from species that are not typically consumed will be for informational purposes only and not considered representative of human health exposures. The more likely a species is to be consumed by anglers, the greater the importance of information.

10.4.10 Trash Monitoring

The following subsections describe the monitoring approaches for the trash TMDLs within the ULAR EWMP area: Los Angeles River Trash TMDL, Echo Park Lake Trash TMDL, and Legg Lake Trash TMDL.

⁸ The Department of Fish and Wildlife (DFW) Sport Fishing Regulations define legal size requirements using total length. All size measurements are in terms of total length.

10.4.10.1 LA River and Echo Park Lake Trash TMDL

The following ULARWMAG members are implementing the Los Angeles River Trash TMDL through the installation of full capture devices: County of Los Angeles and cities of Burbank, Calabasas, Glendale, La Cañada Flintridge, Los Angeles, Montebello, Pasadena, Rosemead, San Fernando, San Gabriel, and South El Monte. As such, no specific monitoring is required or will be conducted for the LA River Trash TMDLs for these jurisdictions. The full capture approach is also being implemented within the drainage area of Echo Park Lake, thereby addressing the requirements of the Echo Park Lake Trash TMDL, including the monitoring requirements.

The following ULARWMAG members are utilizing a combination of full capture, partial capture systems, and/or institutional controls: cities of Alhambra, Hidden Hills, Monterey Park, San Marino, South Pasadena, and Temple City. These jurisdictions are required to measure the effectiveness of partial capture systems and institutional controls through a mass balance approach based on the trash daily generation rate (DGR) for a specific area. However, the Regional Board Executive Officer may approve alternate compliance monitoring programs, upon finding the program will provide an accurate estimate of trash discharged from the MS4.

The most common method for measuring effectiveness and determining compliance is through the use of a DGR. The DGR is the average amount of trash accumulated in a specific land area over a 24-hour period. The DGR is used to estimate the amount of trash discharged after a storm event. The sum of all storm event discharges equals the calculated annual trash discharge for each ULARWMAG member. DGR monitoring will consist of collecting trash on the ground via street sweeping, manual pickup, or other comparable means during thirty consecutive dry weather days.⁹ To allow for a sufficient amount of consecutive dry weather days to occur, DGR monitoring will occur during the summer months of June, July, August, and/or September each year.¹⁰ As DGR monitoring is occurring, the catch basins within the land area where DGR monitoring is taking place will be closed in a manner that prevents trash from being swept into the catch basins. The DGR and storm event discharge will be calculated using the following equations:

$$\text{DGR} = \text{Amount of trash collected during DGR event} / 30 \text{ days}$$
$$\text{Storm Event Discharge} = [\text{days since last street sweeping} * \text{DGR}] - \text{Volume of trash from catch basins}$$

The following information provides the DGR methodology or similar monitoring activities for each agency subject to monitoring requirements:

- **Alhambra:** The City is complying through full capture and institutional controls. Compliance is determined using a mass-balance approach utilizing a DGR. During the trash collection study period (30 days), the City coordinates with the street sweeper schedule. Twenty percent of the City is swept weekly, so an area that includes multiple representative land uses is used to calculate the DGR. Once the percentage of

⁹ For the purposes of DGR monitoring only, dry weather days are defined as days where no measurable precipitation occurs.

¹⁰ Provided no special events are scheduled that may affect the representative nature of this period.

each land use in the study area in comparison to the total area in the City is determined, the total amount of trash collected for each week is obtained. The annual amount of trash discharged is calculated by summing each storm event trash discharge amount [Σ storm events trash discharge (DGR*days since last street sweeping before a storm)]

- **Hidden Hills:** The City of Hidden Hills has been complying with the interim effluent limitations for the Trash TMDL provisions through the implementation of institutional controls. The City has been conducting DGR studies since 2008 to measure the effectiveness of the institutional controls measures in place. The DGR is determined from direct measurement of trash deposited on City's public streets during a 30-day period. To establish the DGR, trash from approximately 10% of the city's curb-miles in designated and representative areas has been collected prior to regularly scheduled street sweepings and from the catch basins in the designated area at the conclusion of the test period. The collected trash has been quantified and used to determine the level of compliance.
- **Monterey Park:** The City of Monterey Park has been complying with the interim effluent limitations for the Trash TMDL provisions through the implementation of a combination of institutional controls and the installation of full and partial capture systems. The City has been conducting DGR studies since 2008 to measure the effectiveness of the institutional controls measures in place. The DGR is determined from direct measurement of trash deposited on City's public streets during a 30-day period. To establish the DGR, trash from approximately 10% of the city's curb-miles in designated and representative areas has been collected prior to regularly scheduled street sweepings. The collected trash has been quantified and used in a mass balance equation to calculate the amount of trash flowing into the storm drain systems to determine the level of compliance.
- **San Marino:** The City is complying through the installation of full capture and partial capture catch basin screens and institutional controls. Compliance is determined using a mass-balance approach utilizing a DGR. During the trash collection study period (30 days), the City coordinates with the street sweeper schedule. The City's main business districts, located along Huntington Drive and Mission Street, receive street sweeping three times per week. The median curb lines along Huntington Drive and Sierra Madre Blvd. are swept on a weekly basis. This median sweeping overlaps portions of the Business Districts and is in addition to the three times a week sweeping that occurs along the curbside on the traffic flow side of Huntington Drive. The remaining areas of the City receive weekly sweeping between November and April (wet weather) and once every other week sweeping between May and October (dry weather). Approximately 60% of the City is swept weekly, so an area that includes multiple representative land uses is used to calculate the DGR. Once the percentage of each land use in the study area in comparison to the total area in the City is determined, the total amount of trash collected for each week is obtained. The collected trash has been quantified and used in a mass balance equation to calculate the amount of trash flowing into the storm drain systems to determine the level of compliance.
- **South Pasadena and Temple City:** The cities of South Pasadena and Temple City have been complying with the interim effluent limitations for the Trash TMDL provisions through the implementation of institutional controls and use the same methods for calculating the DGR. The cities have been conducting DGR studies since 2008 to

measure the effectiveness of the institutional controls measures in place. The DGR is determined from direct measurement of trash deposited on public streets during a 30-day period. To establish the DGR, trash from approximately 10% of the cities' curb-miles in designated and representative areas has been collected prior to regularly schedule street sweepings. The collected trash has been quantified and used in a mass balance equation to calculate the amount of trash flowing into the storm drain systems to determine the level of compliance.

10.4.10.2 Legg Lake Trash TMDL

The Legg Lake Trash TMDL assigns WLAs to the City of South El Monte, County of Los Angeles, and LACFCD, as well as non-point source load allocations (LAs) to the County of Los Angeles. The non-ULARWMAG agencies (City of El Monte and the California Department of Transportation (Caltrans)) are also assigned WLAs. The numeric target for point sources is “zero trash” discharging into Legg Lake and its shoreline and the numeric target for non-point sources is “no trash immediately following each assessment and collection event performed under an approved Minimum Frequency of Collection and Assessment (MFAC) Program”. Point source responsible parties can comply with the WLAs in any lawful manner. However, two compliance methods are presented in the Legg Lake Trash TMDL: (1) installing Executive Officer-approved trash full capture devices; and (2) implementing a MFAC Program coupled with BMP implementation (MFAC/BMP Program).

The City of South El Monte, County of Los Angeles, and LACFCD, along with El Monte and Caltrans, submitted a TMRP on September 5, 2008, which was approved by the Regional Board on March 25, 2009. The TMRP, provided as **Appendix 2**, presents the MFAC/BMP Program for the City of South El Monte, County of Los Angeles, and the LACFCD, which is used to comply with the WLAs and LAs for point sources and non-point sources, respectively.

The MFAC/BMP Program was initiated on September 25, 2009 and has been conducted annually since. The County of Los Angeles Department of Parks and Recreation (DPR) Development Division collects trash and vegetative material from Legg Lake and shoreline areas daily. Fence filter structural BMPs are maintained at least once per week. In addition, the DPR completes daily trash percentage evaluation forms, weekly photographic evaluation surveys, and weekly photographic evidence for the MFAC/BMP Program. TMRP reports are submitted annually to the Regional Board documenting MFAC/BMP Program efforts. As a result of the MFAC/BMP Program, the numeric target of zero trash or no trash immediately following each assessment and collection event, as set forth in the Legg Lake Trash TMDL, has been met at Legg Lake.

The Legg Lake Trash TMDL allows for a reconsideration based on an evaluation of the effectiveness of the MFAC/BMP Program five years from the effective date of the TMDL (March 6, 2013). In addition, the Executive Officer, based on responsible parties monitoring reports, may adjust the MFAC as necessary. As the TMRP annual reports show, the responsible parties are complying with the WLAs and LAs and therefore, the responsible parties will continue to implement the MFAC/BMP Program as described in **Appendix 2**, with the modification of reducing the frequency of photographic documentation and forms to a monthly

frequency consistent with a letter dated April 16, 2014 from the Regional Board Executive Officer to the County of Los Angeles DPR.

11 Quality Control Sample Collection

Quality control samples will be collected in conjunction with environmental samples to verify data quality. Quality control samples collected in the field will generally be collected in the same manner as environmental samples. Detailed descriptions of quality control samples are presented in **Section 11.1** of this Attachment.

11.1 Quality Assurance/Quality Control

This section describes the quality assurance and quality control requirements and processes. Quality control samples will be collected in conjunction with environmental samples to verify data quality. Quality control samples collected in the field will generally be collected in the same manner as environmental samples. There are no requirements for quality control for field analysis of general parameters (e.g., temperature, pH, conductivity, dissolved oxygen, and pH) outlined in SWAMP guidance documents. However, field crews will be required to calibrate equipment as outlined in **Section 10** of this Attachment. **Table 41** presents the quality assurance parameter addressed by each quality assurance requirement as well as the appropriate corrective action if the acceptance limit is exceeded.

Table 41. Quality Control Requirements

Quality Control Sample Type	QA Parameter	Frequency ⁽¹⁾	Acceptance Limits	Corrective Action
Quality Control Requirements – Field				
Equipment Blanks	Contamination	5% of all samples ⁽²⁾	< MDL	Identify equipment contamination source. Qualify data as needed.
Field Blank	Contamination	5% of all samples	< MDL	Examine field log. Identify contamination source. Qualify data as needed.
Field Duplicate	Precision	5% of all samples	RPD < 25% if Difference > RL	Reanalyze both samples if possible. Identify variability source. Qualify data as needed.
Quality Control Requirements – Laboratory				
Method Blank	Contamination	1 per analytical batch	< MDL	Identify contamination source. Reanalyze method blank and all samples in batch. Qualify data as needed.
Lab Duplicate	Precision	1 per analytical batch	RPD < 25% if Difference > RL	Recalibrate and reanalyze.
Matrix Spike	Accuracy	1 per analytical batch	80-120% Recovery for GWQC	Check LCS/CRM recovery. Attempt to correct matrix problem and reanalyze samples. Qualify data as needed.
			75-125% for Metals	
Matrix Spike Duplicate	Precision	1 per analytical batch	50-150% Recovery for Pesticides ⁽³⁾	Check lab duplicate RPD. Attempt to correct matrix problem and reanalyze samples. Qualify data as needed.
			RPD < 30% if Difference > RL	
Laboratory Control Sample (or CRM or Blank Spike)	Accuracy	1 per analytical batch	80-120% Recovery for GWQC	Recalibrate and reanalyze LCS/ CRM and samples.
			75-125% for Metals	
Blank Spike Duplicate	Precision	1 per analytical batch	50-150% Recovery for Pesticides ⁽³⁾	Check lab duplicate RPD. Attempt to correct matrix problem and reanalyze samples. Qualify data as needed.
			RPD < 25% if Difference > RL	
Surrogate Spike (Organics Only)	Accuracy	Each environmental and lab QC sample	30-150% Recovery ⁽³⁾	Check surrogate recovery in LCS. Attempt to correct matrix problem and reanalyze sample. Qualify data as needed.

MDL = Method Detection Limit RL = Reporting Limit RPD = Relative Percent Difference
 LCS = Laboratory Control Sample/Standard CRM = Certified/ Standard Reference Material
 GWQC = General Water Quality Constituents

1. "Analytical batch" refers to a number of samples (not to exceed 20 environmental samples plus the associated quality control samples) that are similar in matrix type and processed/prepared together under the same conditions and same reagents (equivalent to preparation batch).
2. Equipment blanks will be collected by the field crew before using the equipment to collect sample.
3. Or control limits set at + 3 standard deviations based on actual laboratory data.

11.2 QA/QC Requirements and Objectives

11.2.1 Comparability

Comparability of the data can be defined as the similarity of data generated by different monitoring programs. For this monitoring program, this objective will be ensured mainly through use of standardized procedures for field measurements, sample collection, sample preparation, laboratory analysis, and site selection; adherence to quality assurance protocols and holding times; and reporting in standard units. Additionally, comparability of analytical data will be addressed through the use of standard operating procedures and extensive analyst training at the analyzing laboratory.

11.2.2 Representativeness

Representativeness can be defined as the degree to which the environmental data generated by the monitoring program accurately and precisely represent actual environmental conditions. For the CIMP, this objective will be addressed by the overall design of the program. Representativeness is attained through the selection of sampling locations, methods, and frequencies for each parameter of interest, and by maintaining the integrity of each sample after collection. Sampling locations were chosen that are representative of various areas within the watershed and discharges from the MS4, which will allow for the characterization of the watershed and impacts MS4 discharges may have on water quality.

11.2.3 Completeness

Data completeness is a measure of the amount of successfully collected and validated data relative to the amount of data planned to be collected for the project. It is usually expressed as a percentage value. A project objective for percent completeness is typically based on the percentage of the data needed for the program or study to reach valid conclusions.

Because the CIMP is intended to be a long term monitoring program, data that are not successfully collected during a specific sample event may not be recollected at a later date if the goals for data completeness shown in **Table 27** are met. Rather subsequent events conducted over the course of the monitoring will provide robust data sets to appropriately characterize conditions at individual sampling sites and the watershed in general.

However, some reasonable objectives for data are desirable, if only to measure the effectiveness of the program when conditions allow for the collection of samples (i.e., flow is present). The program goals for data completeness, shown in **Table 27**, are based on the planned sampling frequency and SWAMP's Measurement Quality Objective for completeness of 90% (SWRCB 2008). If, however, sampling sites do not allow for the collection of enough samples to provide representative data due to conditions (i.e., no flow) alternate sites will be considered. Data completeness will be evaluated on a yearly basis.

11.3 QA/QC Field Procedures

Quality control samples to be prepared in the field will consist of equipment blanks, field blanks, and field duplicates as described below.

11.3.1 Equipment Blanks

The purpose of analyzing equipment blanks is to demonstrate that sampling equipment is free from contamination. Equipment blanks will be collected by the analytical laboratory responsible for cleaning equipment and analyzed for relevant pollutants before sending the equipment to the field crew. Equipment blanks will consist of laboratory-prepared blank water (certified to be contaminant-free by the laboratory) processed through the sampling equipment that will be used to collect environmental samples.

The equipment blanks will be analyzed using the same analytical methods specified for environmental samples. If any analytes of interest are detected at levels greater than the MDL, the source(s) of contamination will be identified and eliminated (if possible), the affected batch of equipment will be re-cleaned, and new equipment blanks will be prepared and analyzed before the equipment is returned to the field crew for use.

11.3.2 Field Blanks

The purpose of analyzing field blanks is to demonstrate that sampling procedures do not result in contamination of the environmental samples. Per the Quality Assurance Management Plan for SWAMP (SWRCB, 2008) field blanks are to be collected as follows:

- At a frequency of 5% of samples collected for the following constituents: trace metals in water (including mercury), VOC samples in water and sediment, DOC samples in water, and bacteria samples.
- Field blanks for other media and analytes should be conducted upon initiation of sampling, and if field blank performance is acceptable (as described in **Table 41**), further collection and analysis of field blanks for these other media and analytes need only be performed on an as-needed basis, or during field performance audits. An as-needed basis for the ULARWMAG CIMP will be annually.

Field blanks will consist of laboratory-prepared blank water (certified to be contaminant-free by the laboratory) processed through the sampling equipment using the same procedures used for environmental samples.

If any analytes of interest are detected at levels greater than the MDL, the source(s) of contamination should be identified and eliminated, if possible. The sampling crew should be notified so that the source of contamination can be identified (if possible) and corrective measures taken prior to the next sampling event.

11.3.3 Field Duplicates

The purpose of analyzing field duplicates is to demonstrate the precision of sampling and analytical processes. Field duplicates will be prepared at the rate of 5% of all samples, and analyzed along with the associated environmental samples. Field duplicates will consist of two grab samples collected simultaneously, to the extent practicable. If the Relative Percent Difference (RPD) of field duplicate results is greater than the percentage stated in **Table 41** and the absolute difference is greater than the RL, both samples should be reanalyzed, if possible.

The sampling crew should be notified so that the source of sampling variability can be identified (if possible) and corrective measures taken prior to the next sampling event.

11.4 QA/QC Laboratory Analyses

Quality control samples prepared in the laboratory will consist of method blanks, laboratory duplicates, matrix spikes/duplicates, laboratory control samples (standard reference materials), and toxicity quality controls.

11.4.1 Method Blanks

The purpose of analyzing method blanks is to demonstrate that sample preparation and analytical procedures do not result in sample contamination. Method blanks will be prepared and analyzed by the contract laboratory at a rate of at least one for each analytical batch. Method blanks will consist of laboratory-prepared blank water processed along with the batch of environmental samples. If the result for a single method blank is greater than the MDL, or if the average blank concentration plus two standard deviations of three or more blanks is greater than the RL, the source(s) of contamination should be corrected, and the associated samples should be reanalyzed.

11.4.2 Laboratory Duplicates

The purpose of analyzing laboratory duplicates is to demonstrate the precision of the sample preparation and analytical methods. Laboratory duplicates will be analyzed at the rate of one pair per sample batch. Laboratory duplicates will consist of duplicate laboratory fortified method blanks. If the RPD for any analyte is greater than the percentage stated in **Table 41** and the absolute difference between duplicates is greater than the RL, the analytical process is not being performed adequately for that analyte. In this case, the sample batch should be prepared again, and laboratory duplicates should be reanalyzed.

11.4.3 Matrix Spikes and Matrix Spike Duplicates

The purpose of analyzing matrix spikes and matrix spike duplicates is to demonstrate the performance of the sample preparation and analytical methods in a particular sample matrix. Matrix spikes and matrix spike duplicates will be analyzed at the rate of one pair per sample batch. Each matrix spike and matrix spike duplicate will consist of an aliquot of laboratory-fortified environmental sample. Spike concentrations should be added at five to ten times the reporting limit for the analyte of interest.

If the matrix spike recovery of any analyte is outside the acceptable range, the results for that analyte have failed to meet acceptance criteria. If recovery of laboratory control samples is acceptable, the analytical process is being performed adequately for that analyte, and the problem is attributable to the sample matrix. An attempt will be made to correct the problem (e.g., by dilution, concentration, etc.), and the samples and matrix spikes will be re-analyzed.

If the matrix spike duplicate RPD for any analyte is outside the acceptable range, the results for that analyte have failed to meet acceptance criteria. If the RPD for laboratory duplicates is acceptable, the analytical process is being performed adequately for that analyte, and the problem is attributable to the sample matrix. An attempt will be made to correct the problem (e.g., by dilution, concentration, etc.), and the samples and matrix spikes will be re-analyzed.

11.4.4 Laboratory Control Samples

The purpose of analyzing laboratory control samples (or a standard reference material) is to demonstrate the accuracy of the sample preparation and analytical methods. Laboratory control samples will be analyzed at the rate of one per sample batch. Laboratory control samples will consist of laboratory fortified method blanks or a standard reference material. If recovery of any analyte is outside the acceptable range, the analytical process is not being performed adequately for that analyte. In this case, the sample batch should be prepared again, and the laboratory control sample should be reanalyzed.

11.4.5 Surrogate Spikes

Surrogate recovery results are used to evaluate the accuracy of analytical measurements for organics analyses on a sample-specific basis. A surrogate is a compound (or compounds) added by the laboratory to method blanks, samples, matrix spikes, and matrix spike duplicates prior to sample preparation, as specified in the analytical methodology. Surrogates are generally brominated, fluorinated or isotopically labeled compounds that are not usually present in environmental media. Results are expressed as percent recovery of the surrogate spike. Surrogate spikes are applicable for analysis of PCBs and pesticides.

11.4.6 Toxicity Quality Control

For aquatic toxicity tests, the acceptability of test results is determined primarily by performance-based criteria for test organisms, culture and test conditions, and the results of control bioassays. Control bioassays include monthly reference toxicant testing. Test acceptability requirements are documented in the method documents for each bioassay method.

12 Instrument/Equipment Calibration and Frequency

Frequencies and procedures for calibration of analytical equipment used by each contract laboratory are documented in the QA Manual for each laboratory. Any deficiencies in analytical equipment calibration should be managed in accordance with the QA Manual for each contract laboratory. Any deficiencies that affect analysis of samples submitted through this program must be reported to the ULARWMAG. Laboratory QA Manuals are available for review at the analyzing laboratory.

13 Monitoring Procedures References

American Public Health Association. 2012. Standard Methods for the Examination of Water and Wastewater, 22th ed. American Public Health Association, Washington, DC.

Cleaner Rivers Through Effective Stakeholder TMDLs (CREST). 2008. Los Angeles River Bacteriological Source Identification Study. Final Report.

Cowgill, U.M. and D.P. Milazzo. 1990. The sensitivity of two cladocerans to water quality variables, salinity and hardness. Arch. Hydrobiol. 120:185–196.

Gilbreath, A. N., Pearce, S. P. and McKee, L. J. (2012). Monitoring and Results for El Cerrito Rain Gardens. Contribution No. 683. San Francisco Estuary Institute, Richmond, California.

Gilinsky, Ellen (2009). TMDL Guidance Memo No. 09-2001. Guidance for monitoring of point sources for TMDL development using low-level PCB method 1668. Commonwealth of Virginia Department of Environmental Quality, Water Division.

Kayhanian, M., C. Stransky, S. Bay, S. Lau, M.K. Stenstrom. 2008. Toxicity of urban highway runoff with respect to storm duration. *Science of the Total Environment* 389:109-128.

Lee, G. F. and A. Jones-Lee. "Review of the City of Stockton Urban Stormwater Runoff Aquatic Life Toxicity Studies Conducted by the CVRWQCB, DeltaKeeper and the University of California, Davis, Aquatic Toxicology Laboratory between 1994 and 2000," Report to the Central Valley Regional Water Quality Control Board, G. Fred Lee & Associates, El Macero, CA, October (2001).

Palumbo, A., Fojut, T., TenBrook, P. and Tjerdeema, R. 2010a. Water Quality Criteria Report for Diazinon. Prepared for the Central Valley Regional Water Quality Control Board by the Department of Environmental Toxicology, University of California, Davis. March.

Palumbo, A., Fojut, T., Brander, S., and Tjerdeema, R. 2010b. Water Quality Criteria Report for Bifenthrin. Prepared for the Central Valley Regional Water Quality Control Board by the Department of Environmental Toxicology, University of California, Davis. March.

Schiff, K., Bax, B., Markle, P., Fleming, T. and Newman, J. 2007. Wet and Dry Weather Toxicity in the San Gabriel River. *Bulletin of the Southern California Academy of Sciences*: Vol. 106: 3. Available at: <http://scholar.oxy.edu/scas/vol106/iss3/2>

Southern California Coastal Water Research Project (SCCWRP). 2009. Sediment Quality Assessment Draft Technical Support Manual. Technical Report 582.

California State Water Resources Control Board (SWRCB). 2008. Quality Assurance Program Plan. September 1, 2008.

United States Environmental Protection Agency (USEPA). 1991. Methods for Aquatic Toxicity Identification Evaluations: Phase I. Toxicity Characterization Procedures. 2nd Edition. EPA-600-6-91-003. National Effluent Toxicity Assessment Center, Duluth, MN.

United States Environmental Protection Agency (USEPA). 1992. Toxicity Identification Evaluation: Characterization of Chronically Toxic Effluents, Phase I. EPA/600/6-91/005F. May 1992. National Effluent Toxicity Assessment Center, Duluth, MN.

United States Environmental Protection Agency (USEPA). 1993a. Methods for Aquatic Toxicity Identification Evaluations- Phase II Toxicity Identification Procedures for Samples Exhibiting Acute and Chronic Toxicity. EPA-600-R-92-080. National Effluent Toxicity Assessment Center, Duluth, MN.

United States Environmental Protection Agency (USEPA). 1993b. Methods for Aquatic Toxicity Identification Evaluations- Phase III Toxicity Confirmation Procedures for Samples Exhibiting Acute and Chronic Toxicity. EPA-600-R-92-081. National Effluent Toxicity Assessment Center, Duluth, MN.

United States Environmental Protection Agency (USEPA). 1995. Short-term Methods for Estimating the Chronic Toxicity of Effluents and Receiving Waters to West Coast Marine and Estuarine Organisms. EPA-600-R-95-136. August.

U.S. Environmental Protection Agency (USEPA). 1996. Marine toxicity identification evaluation (TIE): Phase I guidance document. EPA/600/R-96/054. National Health and Environmental Effects Research Laboratory. Narragansett, RI.

United States Environmental Protection Agency (USEPA). 2002a. Short-term Methods for Estimating the Chronic Toxicity of Effluents and Receiving Waters to Freshwater Organisms. Fourth Edition. October. EPA-821-R-02-013.

United States Environmental Protection Agency (USEPA). 2002b. Methods for Measuring the Acute Toxicity of Effluent and Receiving Waters to Freshwater and Marine Organisms. Fifth Edition. October. EPA-821-R-02-012.

U.S. Environmental Protection Agency (USEPA). 2007. Sediment toxicity identification evaluation (TIE) phases I, II, and III guidance document. EPA/600/R-07/080. U.S. Environmental Protection Agency, Office of Research and Development, Atlantic Ecology Division. Narragansett, RI.

United States Environmental Protection Agency (USEPA). 2010. National Pollutant Discharge Elimination System Test of Significant Toxicity Technical Document. EPA/833-R-10-004, U.S. Environmental Protection Agency, Office of Environmental Management, Washington, DC.

Weston, D.P. and E.L. Amweg. 2007. Whole sediment toxicity identification evaluation tools for pyrethroid insecticides: II. Esterase addition. *Environmental Toxicology and Chemistry* 26:2397-2404.

Wheelock, C., Miller, J., Miller, M., Gee, S., Shan, G. and Hammock, B. 2004. Development of Toxicity Identification Evaluation (TIE) procedures for pyrethroid detection using esterase activity. *Environmental Toxicology and Chemistry* 23:2699-2708.

Attachment D. Data Management and Reporting

Attachment D details the procedures for managing and reporting data meet the goals and objectives of the CIMP and in turn the Permit. The details contained herein serve as a guide for ensuring that consistent protocols and procedures are in place for successful data management and reporting. **Attachment D** is divided into the following sections:

- Data Management, Validation, and Usability
- Reporting

14 Data Management, Validation, and Usability

The ULARWMAG will maintain an inventory of data and its forms. After each sampling event, data collected in the ULARWMAG CIMP will be verified and validated before it is deemed ready for reporting. This section describes the process that the ULARWMAG will take to verify and validate the collected data.

14.1 Data Review, Verification, and Validation Requirements

The acceptability of data is determined through data verification and data validation. Both processes are discussed in detail below. In addition to the data quality objectives presented in **Table 27**, the standard data validation procedures documented in the contract laboratory's QA Manual will be used to accept, reject, or qualify the data generated by the laboratory. Each laboratory's QA Officer will be responsible for validating data generated by the laboratory.

Once analytical results are received from the analyzing laboratory, the ULARWMAG will perform an independent review and validation of analytical results. **Appendix 3** provides equations that are used to calculate precision, accuracy, and completeness of the data. Decisions to reject or qualify data will be made by the ULARWMAG, based on the evaluation of field and laboratory quality control data, according to procedures outlined in Section 13 of Caltrans document No. CTSW-RT-00-005, *Guidance Manual: Stormwater Monitoring Protocols, 2nd Edition* (LWA, 2000). Section 13 of the Caltrans Guidance Manual is included as **Appendix 4**.

14.1.1 Data Verification

Data verification involves verifying that required methods and procedures have been followed at all stages of the data collection process, including sample collection, sample receipt, sample preparation, sample analysis, and documentation review for completeness. Verified data have been checked for a variety of factors, including transcription errors, correct application of dilution factors, appropriate reporting of dry weight versus wet weight results, and correct application of conversion factors. Verification of data may also include laboratory qualifiers, if assigned.

Data verification should occur in the field and the laboratory at each level (i.e., all personnel should verify their own work) and as information is passed from one level to the next (i.e., supervisors should verify the information produced by their staff). Records commonly examined

during the verification process include field and sample collection logs, COC forms, sample preparation logs, instrument logs, raw data, and calculation worksheets.

In addition, laboratory personnel will verify that the measurement process was "in control" (i.e., all specified data quality objectives were met or acceptable deviations explained) for each batch of samples before proceeding with the analysis of a subsequent batch. Each laboratory will also establish a system for detecting and reducing transcription and/or calculation errors prior to reporting data.

14.1.2 Data Validation

In general, data validation involves identifying project requirements, obtaining the documents and records produced during data verification, evaluating the quality of the data generated, and determining whether project requirements were met. The main focus of data validation is determining data quality in terms of accomplishment of measurement quality objectives (i.e., meeting QC acceptance criteria). Data quality indicators, such as precision, accuracy, sensitivity, representativeness, and completeness, are typically used as expressions of data quality. The ULARWMAG, will review verified sample results for the data set as a whole, including laboratory qualifiers, summarize data and QC deficiencies and evaluate the impact on overall data quality, assign data validation qualifiers as necessary, and prepare an analytical data validation report. The validation process applies to both field and laboratory data.

In addition to the data quality objectives presented in **Table 27**, the standard data validation procedures documented in the analyzing laboratory's QA Manual will be used to accept, reject, or qualify the data generated. The laboratory will only submit data that have met data quality objectives, or data that have acceptable deviations explained. When QC requirements have not been met, the samples will be reanalyzed when possible, and only the results of the reanalysis will be submitted, provided that they are acceptable. Each laboratory's QA Officer is responsible for validating the data it generates.

14.1.3 Data Management

Analytical Data Reports will be sent to and kept by the ULARWMAG. Each type of report will be stored separately and ordered chronologically. The field crew shall retain the original field logs. The contract laboratory shall retain original COC forms. The contract laboratory will retain copies of the preliminary and final data reports. Concentrations of all parameters will be calculated as described in the laboratory Standard Operating Procedures (SOPs) or referenced method document for each analyte or parameter.

The field log and analytical data generated will be converted to a standard database format maintained on personal computers. After data entry or data transfer procedures are completed for each sample event, data will be validated as described in **Appendix 4**. After the final quality assurance checks for errors are completed, the data will be added to the final database.

15 Reporting

The MRP includes a number of reporting requirements to summarize CIMP implementation efforts, the data collected as part of the CIMP, as well as to report on implementation of the Permit requirements as a whole. The following sections detail monitoring and reporting requirements outlined in the MRP and provides information on how the water, sediment, and tissue data collected as part of this CIMP data are to be used.

15.1 Semi-Annual Analytical Data Reports

As required by Part XIV.L of the MRP, results from each of the receiving water or outfall based monitoring stations conducted in accordance with the SOP shall be sent electronically to the Regional Board's Stormwater site at MS4stormwaterRB4@waterboards.ca.gov. The monitoring results will be submitted on a semi-annual basis and will highlight exceedances applicable to WQBELs, RWLs, action levels, or aquatic toxicity thresholds. Corresponding sample dates and monitoring locations will be included. Data will be transmitted in the most recent Southern California SMC's Standardized Data Transfer Formats. Reports of monitoring activities will include, at a minimum, the following information (records of which are required by Part XIV.A.1.c of the MRP):

1. The date, time of sampling or measurements, exact place, weather conditions, and rain fall amount.
2. The individual(s) who performed the sampling or measurements.
3. The date(s) analyses were performed.
4. The individual(s) who performed the analyses.
5. The analytical techniques or methods used.
6. The results of such analyses.
7. The data sheets showing toxicity test results.

15.2 Annual Monitoring Reports

As outlined in Part XVI.A of the MRP, the annual reporting process is intended to provide the Regional Board with summary information to allow for the assessment of the Permittee's:

1. Participation in one or more Watershed Management Programs.
2. Impact of each Permittee(s) stormwater and NSW discharges on the receiving water.
3. Each permittee's compliance with RWLs, numeric WQBELs, and action levels.
4. The effectiveness of each Permittee(s) control measures in reducing discharges of pollutants from the MS4 to receiving waters.
5. Whether the quality of MS4 discharges and the health of receiving waters is improving, staying the same, or declining as a result of watershed management program efforts, and/or TMDL implementation measures, or other MCMs.
6. Whether changes in water quality can be attributed to pollutant controls imposed on new development, re-development, or retrofit projects.

The annual report process also seeks to provide a forum for Permittee(s) to discuss the effectiveness of its past and ongoing control measure efforts and to convey its plans for future

control measures. Detailed data and information will also be provided in a clear and transparent fashion to allow the Regional Board and the general public to review and verify conclusions presented by the Permittee. Annual reports shall be organized to include the information as described in the following subsections.

15.3 Watershed Summary Information

According to Section XVII.B of the MRP, Permittees shall include the information requested in MRP Section XVII.B parts A.1 through A.3 in its odd year Annual Report (e.g., Year 1, 3, 5). The requested information shall be provided for each watershed within the Permittee's jurisdiction. Alternatively, Permittees participating in a EWMP may provide the requested information through the development and submission of a EWMP plan and any updates. As the ULARWMG is submitting an EWMP the information is not required as a separate submittal. However, updates to information requested in Section XVII.B parts A.1 through A.3 (presented in **Sections 15.3.1** through **15.3.3** below) will be noted in EWMP plan updates.

15.3.1 Watershed Management Area

When a Permittee has collaboratively developed an EWMP, reference to the EWMP and any revisions to the EWMP may suffice for baseline information regarding the following watershed management area details:

1. The effective TMDLs, applicable WQBELs and RWLs, and implementation and reporting requirements, and compliance dates.
2. CWA section 303(d) listings of impaired waters not addressed by TMDLs.
3. Results of regional bioassessment monitoring.
4. A description of known hydromodifications to receiving waters and a description, including locations, of natural drainage systems.
5. Description of groundwater recharge areas including number and acres.
6. Maps and/or aerial photographs identifying the location of Environmentally Sensitive Areas (ESAs), Areas of Special Biological Significance (ASBS), natural drainage systems, and groundwater recharge areas.

15.3.2 Subwatershed (HUC-12) Descriptions

When a Permittee has collaboratively developed an EWMP, reference to the EWMP and any revisions to the EWMP may suffice for information regarding the following Subwatershed (twelve digit Hydrologic Unit Code or HUC-12) descriptions:

1. Description including HUC-12 number, name and a list of all tributaries named in the Basin Plan.
2. Land use map of the HUC-12 watershed.
3. 85th percentile, 24-hour rainfall isohyetal map for the subwatershed.
4. One-year, one-hour storm intensity isohyetal map for the subwatershed.
5. MS4 map for the subwatershed, including major MS4 outfalls and all low-flow diversions.

15.3.3 Description of Permittee(s) Drainage Area within the Subwatershed

When a Permittee has collaboratively developed an EWMP, reference to the EWMP and any revisions to the EWMP may suffice for information regarding the Drainage Area within the subwatershed:

1. A subwatershed map depicting the Permittee(s) jurisdictional area and the MS4, including major outfalls (with identification numbers), and low flow diversions located within the Permittee(s) jurisdictional area.
2. Provide the estimated baseline percent of effective impervious area (EIA) within the Permittee(s) jurisdictional area.

15.3.4 Annual Assessment and Reporting

The following sections will be included in the ULARWMA Annual Report to meet the MRP requirements. The Annual Report will clearly identify all data collected and strategies, control measures, and assessments implemented by each Permittee within the ULARWMA, as well as those implemented by multiple Permittees on a watershed scale.

15.3.4.1 Stormwater Control Measures

All reasonable efforts will be made to determine, compile, analyze, and summarize the following information for each Permittee:

1. Estimated cumulative change in percent EIA since the effective date of the Order, and if possible, the estimated change in the stormwater runoff volume during the 85th percentile storm event.
2. Summary of New Development/Re-Development Projects constructed within the Permittee(s) jurisdictional area during the reporting year.
3. Summary of Retrofit Projects that reduced or disconnected impervious area from MS4 during the reporting year.
4. Summary of other projects designed to intercept stormwater runoff prior to discharge to the MS4 during the reporting year.
5. Estimate the total runoff volume retained on site by the implementation of such projects during the reporting year.
6. Summary of actions taken in compliance with TMDL implementation plans or approved EWMP to implement TMDL provisions.
7. Summary of riparian buffer/wetland restoration projects completed during the reporting year. For riparian buffers include width, length and vegetation type; for wetland include acres restored, enhanced, or created.
8. Summary of other MCMs implemented during the reporting year, as the Permittee deems relevant.
9. Status of all multi-year efforts that were not completed in the current year and will therefore continue into the subsequent year(s). Additionally, if any of the requested information cannot be obtained, the Permittee(s) will provide a discussion of the factor(s) limiting its acquisition and steps that will be taken to improve future data collection efforts.

15.3.4.2 Effectiveness Assessment of Stormwater Control Measures

The following information will be included to detail Stormwater Control Measures during the reporting year:

1. Rainfall summary for the reporting year, including the number of storm events, highest volume event (inches/24 hours), highest number of consecutive days with measurable rainfall, total rainfall during the reporting year compared to average annual rainfall for the EWMP area.
2. A summary table describing rainfall during stormwater outfall and wet-weather receiving water monitoring events. The summary description will include the date, time that the storm commenced and the storm duration in hours, the highest 15-minute recorded storm intensity (converted to inches/hour), the total storm volume (inches), and the time between the storm event sampled and the end of the previous storm event.
3. Where control measures were designed to reduce impervious cover or stormwater peak flow and flow duration, hydrographs or flow data of pre- and post-control activity for the 85th percentile, 24-hour rain event, if available.
4. For natural drainage systems, a reference watershed flow duration curve and comparison to a flow duration curve for the EWMP area under current conditions.
5. An assessment as to whether the quality of stormwater discharges as measured at designed outfalls is improving, staying the same, or declining. Water quality data may be compared from the reporting year to previous years with similar rainfall patterns, a trends analysis may be conducted, or other means may be used to develop and support the assessment's conclusions.
6. An assessment as to whether wet-weather receiving water quality is improving, staying the same or declining, when normalized for variations in rainfall patterns. Water quality data may be compared from the reporting year to previous years with similar rainfall patterns, a trends analysis may be conducted, regional bioassessment studies may be drawn from, or other means may be used to develop and support the assessment's conclusions.
7. Status of all multi-year efforts, including TMDL implementation, which were not completed in the current year and will continue into the subsequent year(s). Additionally, if any of the requested information cannot be obtained, a discussion of the factor(s) limiting its acquisition and steps that will be taken to improve future data collection efforts will be provided.

15.3.4.3 Non-stormwater Water Control Measures

The following information will be included to detail non-stormwater (NSW) control measures:

1. An estimation of the number of major outfalls within the EWMP area.
2. The number of outfalls that were screened for significant NSW discharges during the reporting year.
3. The cumulative number of outfalls that have been screened for significant NSW discharges since the date the Permit was adopted through the reporting year.
4. The number of outfalls with confirmed significant NSW discharge.
5. The number of outfalls where significant NSW discharge was attributed to other NPDES permitted discharges; other authorized NSW discharges; or conditionally exempt

discharges.

6. The number of outfalls where significant NSW discharges were abated as a result of the ULARWMAG's actions.
7. The number of outfalls where NSW discharges was monitored.
8. The status of all multi-year efforts, including TMDL implementation, which were not completed in the current year and will continue into the subsequent year(s). Additionally, if any of the requested information cannot be obtained, a discussion of the factor(s) limiting its acquisition and steps that will be taken to improve future data collection efforts will be provided.

15.3.4.4 Effectiveness Assessment of Non-Stormwater Control Measures

The following information will be included to assess NSW control measures effectiveness:

1. An assessment as to whether receiving water quality within the EMWP area is impaired, improving, staying the same or declining during the dry-weather conditions. Water quality data from the reporting year to previous years with similar dry-weather flows may be compared, a trends analysis may be conducted, regional bioassessment studies may be drawn from, or other means may be used to develop and support the assessment's conclusions.
2. An assessment of the effectiveness of the control measures in effectively prohibiting NSW discharges through the MS4 to the receiving water.
3. The status of all multi-year efforts that were not completed in the current year and will continue into the subsequent year(s).

15.3.4.5 Integrated Monitoring Compliance Report

The following information will be included to assess the Permittee(s) compliance with applicable TMDLs, WQBELs, RWLs, and action levels:

1. An Integrated Monitoring Report that summarizes all identified exceedances of the following against applicable RWLs, WQBELs, action levels, and aquatic toxicity thresholds:
 - a. Outfall-based stormwater monitoring data
 - b. Wet weather receiving water monitoring data
 - c. Dry weather receiving water data
 - d. NSW outfall monitoring dataAll sample results that exceeded one more applicable thresholds shall be readily identified.
2. If aquatic toxicity was confirmed and a TIE was conducted, the toxic chemicals, as determined by the TIE, will be identified. All relevant data to allow the Regional Board to review the adequacy and findings of the TIE will be included. This shall include, but not be limited to:
 - a. The sample(s) date
 - b. Sample(s) start and end time
 - c. Sample type(s)
 - d. Sample location(s) as depicted on a map
 - e. The parameters, analytical results, and applicable limitation.

3. A description of efforts that were taken to mitigate and/or eliminate all NSW discharges that exceeded one or more applicable WQBELs, or caused or contributed to Aquatic Toxicity.
4. A description of efforts that were taken to address stormwater discharges that exceeded one or more applicable WQBELs, or caused or contributed to Aquatic Toxicity.
5. Where RWLs were exceeded, provide a description of efforts that were taken to determine whether discharges from the MS4 caused or contributed to the exceedances and all efforts that were taken to control the discharge of pollutants from the MS4 to those receiving waters in response to the exceedances.

15.3.4.6 Adaptive Management Strategies

The following information will be included to outline Adaptive Management Strategies:

1. The most effective control measures, why the measures were effective, and how other measures will be optimized based on past experiences.
2. The least effective control measures, why the measures were deemed ineffective, and how the controls measures will be modified or terminated.
3. Significant changes to control measures during the prior year and the rationale for the changes.
4. All significant changes to control measures anticipated to be made next year and rationale for the changes. Those changes requiring approval of the Regional Board or its Executive Officer will be clearly identified at the beginning of the Annual Report.
5. A detailed description of control measures to be applied to New Development or Re-development projects disturbing more than 50 acres.
6. The status of all multi-year efforts that were not completed in the current year and will continue into the subsequent year(s).

15.3.4.7 Supporting Data and Information

All monitoring data and associated meta-data used to prepare the Annual Report will be summarized in an MS Excel© spreadsheet and sorted by monitoring station/outfall identifier linked to the EWMP area map. The data summary will include the date, sample type (flow-weighted composite, grab, field measurement), sample start and stop times, parameter, analytical method, value, and units. The date field will be linked to a database summarizing the weather data for the sampling date including 24-hour rainfall, rainfall intensity, and days since the previous rain event.

15.4 Signatory and Certification Requirements

All applications, reports, or information submitted to the Regional Board, State Board, and/or USEPA will be signed and certified as follows:

1. All applications submitted to the Regional Board shall be signed by either a principal executive officer or ranking elected official. For purposes of this section, a principal executive officer includes: (i) the chief executive officer of the agency (e.g., Mayor), or (ii) a senior executive officer having responsibility for the overall operations of a principal geographic unit of the agency (e.g., City Manager, Director of Public Works, City Engineer, etc.).

2. All reports required by the Permit and other information requested by the Regional Board, State Board, or USEPA shall be signed by either a principal executive officer or ranking elected official or by a duly authorized representative of a principal executive officer or ranking elected official. A person is a duly authorized representative only if:
 - a. The authorization is made in writing by a principal executive officer or ranking elected official.
 - b. The authorization specifies either an individual or a position having responsibility for the overall operation of the regulated facility or activity such as the position of plant manager, operator of a well or a well field, superintendent, position of equivalent responsibility, or an individual or position having overall responsibility for environmental matters for the company. (A duly authorized representative may thus be either a named individual or any individual occupying a named position.)
 - c. The written authorization is submitted to the Regional Board.
3. If an authorization of a duly authorized representative is no longer accurate because a different individual or position has responsibility for the overall operation of the facility, a new authorization will be submitted to the Regional Board prior to or together with any reports, information, or applications, to be signed by an authorized representative.
4. The following certification will be made by any person signing an application or report:

“I certify under penalty of law that this document and all attachments were prepared under my direction or supervision in accordance with a system designed to assure that qualified personnel properly gather and evaluate the information submitted. Based on my inquiry of the person or persons who manage the system or those persons directly responsible for gathering the information, the information submitted is, to the best of my knowledge and belief, true, accurate, and complete. I am aware that there are significant penalties for submitting false information, including the possibility of fine and imprisonment for knowing violations.”

15.5 Use of Submitted Data

As stated in Part II.A.2 of the MRP, a Primary Objective of the Monitoring Program is to assess compliance with RWLs and WQBELs established to implement TMDL wet weather and dry weather WLAs. As such, a discussion of how the compliance evaluation will be conducted is warranted and is presented below.

15.5.1 Compliance Evaluation

The compliance evaluation will take into consideration the relationship between the types of monitoring and the pathways for determining compliance outlined in the Permit. For example, the receiving water monitoring sites meet the MRP objectives and support an understanding of potential impacts associated with MS4 discharges. However, as described in the MRP (Part II.E.1), receiving water sites are intended to assess receiving water conditions. An exceedance of a RWL at a receiving water site does not on its own indicate MS4 discharges caused or contributed to the RWL exceedance. As the receiving water sites also receive runoff from non-MS4 sources, including open space and other permitted discharges, the exceedance of a RWL may have been caused or contributed to by a non-MS4 source. Additionally, an exceedance at an outfall location when the corresponding downstream receiving water location is

in compliance with the water quality objectives and RWLs does not constitute an exceedance of a WQBEL.

Finally, reporting of compliance will be accomplished by evaluating the data, in addition to the status of EWMP implementation consistent with the Permit (Parts VI.C.2, VI.C.3 and VI.E.2). Generally, reporting of compliance will consider whether the following conditions, as applicable, are met:

1. There are no violations of the effective WQBEL (i.e., interim or final) for the specific pollutant at the Permittee’s applicable MS4 outfall(s).
2. There are no exceedances of an applicable RWLs for the specific pollutant in the receiving water(s) at, or downstream of, the Permittee’s outfall(s).
3. There is no direct or indirect discharge from the Permittee’s MS4 to the receiving water during the time period subject to the WQBEL and/or RWL for the pollutant(s) associated with a specific TMDL.
4. In drainage areas where Permittees are implementing an EWMP, (i) all non-stormwater and (ii) all stormwater runoff up to and including the volume equivalent to the 85th percentile, 24-hour event is retained for the drainage area tributary to the applicable receiving water.
5. The approved ULARWMG EWMP is being implemented pursuant to Part VI.C of the Permit.
6. Conditions of effective Time Schedule Orders (TSOs) are met.
7. Exceedances of RWLs not otherwise addressed by a TMDL are addressed pursuant to Part VI.C.2 of the Permit.

In addition, evaluation of compliance for pollutants subject to TMDLs will consider the requirements specified in the applicable TMDLs described in the following subsections.

15.5.1.1 LAR Metals TMDL Interim Milestones Compliance Determination

Per the Metals TMDL, the ULARWMAG is required to show an increase in the percent of the total watershed meeting dry and wet weather WLAs phased over a 16-year period. **Table 42** lists the compliance milestone dates as well as the required percent compliance for the total watershed. The percent compliance for the ULARWMAG will be calculated using an annual average. The annual average will be determined by averaging the total percentage for all of the sampling events occurring during an individual year to adequately characterize the dry or wet weather conditions for the reporting period.

Table 42. Compliance Milestone Dates and Required Percent Compliance

Compliance Milestone Date	Dry Weather Percent of Total Drainage Area Served by MS4 Meeting WLA	Wet Weather Percent of Total Drainage Area Served by MS4 Meeting WLA
January 11, 2012	50%	25%
January 11, 2020	75%	Not Applicable
January 11, 2024	100%	50%
January 11, 2028	100%	100%

15.5.1.2 LA River Trash TMDL Compliance Determination

As described in **Section 10.4.10 of Attachment C**, a group of ULARWMAG members are complying with the LAR Trash TMDL WQBELs through a combination of full capture, partial capture, and/or institutional controls. Each year, details regarding how each ULARWMAG member is either implementing full capture in a manner consistent with the implementation schedule or how those using a combination of full capture, partial capture, and/or institutional controls calculated its DGR will be presented in the Annual Report.

15.5.1.3 Lakes TMDLs Special Considerations

The TMDL monitoring requirements specified in the MRP for each of the Lakes TMDLs within the ULARWMAG EWMP area are presented in **Section 2.7 of Attachment A**. To meet the “Stormwater Monitoring” requirements of the TMDLs, stormwater outfall data from the stormwater outfall monitoring sites which represent the subwatershed in which each lake is located will be used to represent the stormwater discharges to each lake. For example, Legg Lake is located within the Rio Hondo subwatershed. As such, the data collected at the stormwater outfall monitoring site which represents the Rio Hondo subwatershed (RH_SW_ROB) will be used to represent stormwater discharges into Legg Lake. As detailed in the CIMP, the Lakes TMDLs monitoring requirements specified in the MRP were considered when choosing the parameters which will be monitored at each stormwater outfall monitoring site which will be used to represent discharges to the lakes subject to TMDL monitoring requirements. To estimate stormwater flows entering each of the lakes, the rational method or the watershed model used to develop the EWMP will be used, and the chosen calculation method will be detailed in the Annual Report.

Regarding Echo Park Lake, if samples from both Echo Park Lake receiving water monitoring sites (EPL_1 and EPL_2) are collected, these results will be averaged and the averaged result will be used to determine whether TMDL targets are being attained.

15.5.1.4 Use of Specie-Specific Data for Chlordanes, PCBs, and PAHs

Chlordanes, PCBs, and PAHs are unique in that they are pollutant categories which may be analyzed for the species that make up the pollutant category and the species of interest varies depending on the purpose of data collection. The individual constituents are summed to determine “total” concentrations. The following describes how individual chlordane, PCB, and PAH species will be summed for comparison to applicable WQBELs, RWLs, TMDL targets, WLAs, and/or State adopted objectives.

Analysis included in this CIMP for chlordane includes the following species: alpha-chlordane, gamma-chlordane, oxychlordane, cis-Nonachlor, and trans-Nonachlor. The calculation of total chlordane will be conducted as follows:

- When evaluating sediment concentrations and loads associated with the direct effects California Sediment Quality Objectives, quantified concentrations of alpha-chlordane, gamma-chlordane, trans-Nonachlor will be summed.
- When evaluating sediment concentrations and loads and tissue concentrations associated with indirect effects, quantified concentrations of alpha-chlordane, gamma-chlordane, oxychlordane, cis-Nonachlor, and trans-Nonachlor will be summed.

- Upon approval by the State Board, for the purposes of conducting analyses associated with the Decision Support Tool (DST) for determining impairment due to indirect effects associated with sediment concentrations, data for each species will be utilized in a manner consistent with the supporting documentation.

Analysis included in this CIMP for PCBs includes the following species: Aroclors 1016, 1221, 1232, 1242, 1248, 1254, 1260 and congeners 8, 18, 28, 31, 33, 37, 44, 49, 52, 56, 60, 66, 70, 74, 77, 81, 87, 95, 97, 99, 101, 105, 110, 114, 118, 119, 123, 126, 128, 132, 138, 141, 149, 151, 153, 156, 157, 158, 167, 168, 169, 170, 174, 177, 180, 183, 187, 189, 194, 195, 201, 203, 206, and 209. The calculation of total PCBs will be conducted as follows:

- When evaluating water concentrations for the purposes of comparing to the California Toxics Rule (CTR) aquatic life criteria, quantified concentrations of aroclors 1016, 1221, 1232, 1242, 1248, 1254, 1260 will be summed.
- When evaluating water concentrations for the purposes of comparing to the CTR human health criteria, quantified concentrations of aroclors 1016, 1221, 1232, 1242, 1248, 1254, 1260 or congeners 8, 18, 28, 31, 33, 37, 44, 49, 52, 56, 60, 66, 70, 74, 77, 81, 87, 95, 97, 99, 101, 105, 110, 114, 118, 119, 123, 126, 128, 132, 138, 141, 149, 151, 153, 156, 157, 158, 167, 168, 169, 170, 174, 177, 180, 183, 187, 189, 194, 195, 201, 203, 206, and 209 will be summed.
- When evaluating sediment concentrations and loads associated with the direct effects California Sediment Quality Objectives, quantified concentrations of congeners 8, 18, 28, 44, 52, 66, 101, 105, 118, 128, 138, 153, 170, 180, 187, 189, 195, 206, and 209 will be summed.
- When evaluating sediment and tissue samples associated with indirect effects, quantified concentrations of congeners 18, 28, 37, 44, 49, 52, 66, 70, 74, 77, 81, 87, 99, 101, 105, 110, 114, 118, 119, 123, 126, 128, 138, 149, 151, 153, 156, 157, 158, 167, 168, 169, 170, 177, 180, 183, 187, 189, 194, 201, and 206 will be summed.
- Upon approval by the State Board, for the purposes of conducting analyses associated with the DST for determining impairment due to indirect effects associated with sediment concentrations, data for each species will be utilized in a manner consistent with the supporting documentation.

Analysis included in this CIMP for PAHs includes the following constituents: acenaphthene, anthracene, biphenyl, naphthalene, 2,6-dimethylnaphthalene, fluorene, 1-methylnaphthalene, 2-methylnaphthalene, 1-methylphenanthrene, phenanthrene, benzo(a)anthracene, benzo(a)pyrene, benzo(e)pyrene, chrysene, dibenz(a,h)anthracene, fluoranthene, perylene, and pyrene. The calculation of total PAHs will be conducted as follows:

- When evaluating sediment and tissue samples associated with direct and indirect effects, quantified concentrations of acenaphthene, anthracene, biphenyl, naphthalene, 2,6-dimethylnaphthalene, fluorene, 1-methylnaphthalene, 2-methylnaphthalene, 1-methylphenanthrene, phenanthrene, benzo(a)anthracene, benzo(a)pyrene, benzo(e)pyrene, chrysene, dibenz(a,h)anthracene, fluoranthene, perylene, and pyrene will be summed.
- Upon approval by the State Board, for the purposes of conducting analyses associated

with the DST for determining impairment due to indirect effects associated with sediment concentrations, data for each species will be utilized in a manner consistent with the supporting documentation.

Appendix 1

Example Field, Calibration and Chain-of-Custody Forms

GENERAL INFORMATION		Date: _____
Site ID: _____	Sampling Personnel: _____	
GPS Coordinates: (lat) _____ (lon) _____	Picture/Video #: _____	

OBSERVATIONS

Weather: _____

Water Color: _____ In stream Activity: _____

Water Characteristics (flow type, odor, turbidity, floatables): _____

Other comments (trash, wildlife, recreational uses, homeless activity, etc. – Use notes section if more room is needed):

***In situ* WATER QUALITY MEASUREMENTS**

Time	Temp (°C)	pH	D.O. (mg/L)	D.O. % Sat	Elec Cond. (uS/cm)	Turbidity (NTU)

COLLECTED WATER QUALITY SAMPLES

Sample ID	Analysis	Time	Volume	Notes
				Field blank
				Field duplicate

ADDITIONAL WATER QUALITY SAMPLING NOTES:

FLOW MEASUREMENTS WITH VELOCITY METER

Estimated Total Width of Flowing Water (ft): _____ Distance measured from (circle): RIGHT or LEFT

Measurement Number	1	2	3	4	5	6	7	8	9	10	11	12	13	14
Distance from Bank (ft)														
Depth (ft)														
Velocity (ft/s)														

FLOW MEASUREMENTS WITH FLOAT AND STOPWATCH Number of Flow Paths: _____

Fill out Path # →	Path#	Path#	Path#	Path#	Path#
Width of Flow at Top of Marked Section:					
Width of Flow at Middle of Marked Section:					
Width of Flow at Bottom of Marked Section:					
Depth of Flow at 0% of Top Marked Section:					
Depth of Flow at 25% of Top Marked Section:					
Depth of Flow at 50% of Top Marked Section:					
Depth of Flow at 75% of Top Marked Section:					
Depth of Flow at 100% of Top Marked Section:					
Depth of Flow at 0% of Middle Marked Section:					
Depth of Flow at 25% of Middle Marked Section:					
Depth of Flow at 50% of Middle Marked Section:					
Depth of Flow at 75% of Middle Marked Section:					
Depth of Flow at 100% of Middle Marked Section:					
Depth of Flow at 0% of Bottom Marked Section:					
Depth of Flow at 25% of Bottom Marked Section:					
Depth of Flow at 50% of Bottom Marked Section:					
Depth of Flow at 75% of Bottom Marked Section:					
Depth of Flow at 100% of Bottom Marked Section:					
Distance Marked-off for Velocity:					
Time 1:					
Time 2:					
Time 3:					

Specify if measurements are in inches or feet using “in” or “ft”

FLOW MEASUREMENT WITH GRADUATED CONTAINER

Container Volume: _____ Percent Capture: _____

Time to fill container:

	Minutes	Seconds
Time1		
Time2		
Time3		

ADDITIONAL FLOW MEASUREMENT NOTES:

EXAMPLE Field Meter Calibration Logsheet

Field Measurement Equipment Calibration Log & Initial Calibration Verification

Date:

Parameter	Meter ID	Calibration Standard	Post-Cal Measurement	Calibration Valid if:	Time	Initials
Dissolved Oxygen		_____ mmHG _____ °C _____ mg/L ¹	_____ mg/L (water-sat'd air)	D.O. reads within 10% of value from D.O. tables ¹		
Conductivity		0 uS/cm (air)				
		10,000 uS/cm	_____ uS/cm (1,000 uS/cm)	900 - 1,100 uS/cm		
pH		7.0 Units				
		10.0 Units	_____ Units (pH = 8.0)	pH 8 = 7.8 - 8.2 (or w/in manuf's specs)		
Turbidity		0 NTU				
		3000 NTU	_____ NTU (1000 NTU)	NTU = 900 - 110		

Notes:

Field Measurement Equipment Post Event Calibration Verification Log

Date:

Parameter	Meter ID	Verification Standard	Measurement	Calibration Valid if:	Time	Initials
Dissolved Oxygen		_____ mmHG _____ °C _____ mg/L ¹	_____ mg/L (water-sat'd air)	D.O. reads within 10% of value from D.O. tables		
Conductivity		_____ uS/cm	_____ uS/cm (1,000 uS/cm)	EC of 1,000 std = 900 - 1,100 uS/cm		
pH		_____ Units	_____ Units (pH = 8.0)	pH 8.0 = 7.8 - 8.2 (or w/in manuf's specs)		
Turbidity		_____ NTU	_____ NTU (1,000 NTU)	NTU = 900 - 1,100		

Notes:

¹ "D.O. tables" refers to tables of dissolved oxygen in water as a function of temperature and barometric pressure, typically found in wastewater engineering text books.

Appendix 2

Legg Lake Trash Monitoring and Reporting Program



PREPARED BY THE
LEGG LAKE TRASH TMDL JURISDICTIONAL GROUP

Trash Monitoring & Reporting Plan: Legg Lake Trash TMDL

SEPTEMBER 5, 2008





LEGG LAKE TRASH TMDL JURISDICTIONAL GROUP

Trash Monitoring & Reporting Plan:

Legg Lake Trash TMDL

SEPTEMBER 5, 2008

Table of Contents

	Page
Executive Summary	1
SECTION 1 – An Overview	
1.1 – Introduction	2
1.2 – Regulatory Background	3
1.3 – TMDL Provisions	4
1.3.1 – Load Allocations	5
1.3.2 – Waste Load Allocations	5
1.3.3 – Numeric Targets	7
1.4 – Monitoring and Reporting Plan Development	8
1.5 – Major Rainfall Event Definition	9
SECTION 2 – Point Sources	
2.1 – Existing Trash Generation Study	10
2.2 – Synopsis of Existing Trash Generation Study	10
2.3 – Implementation Strategies	12
2.3.1 – City of South El Monte	13
2.3.2 – City of El Monte	19
2.3.3 – The State of California Department of Transportation	22
SECTION 3 – Non-point Sources	
3.1 – non-point Source Monitoring Plan	24
3.2 – Reporting Plan Development	27
3.3 – Implementation Strategies	28
3.3.1 – City of South El Monte	28
3.3.2 – County of Los Angeles	30
3.3.3 – The State of California Department of Transportation	31

List of Tables

Table 1	Monitoring and Implementation Plan Schedule
---------	---

List of Figures

Figure 1.1	Legg Lake Watershed Map
Figure 1.2	Legg Lake Vicinity Map
Figure 1.3	Legg Lake Point Source Map
Figure 1.4a	Grated Fence/Filter Design
Figure 1.4b	Non-Grated Fence/Filter Design
Figure 1.5	Monitoring Plan Location Map
Figure 1.6	Photographic Evaluation Survey Form
Figure 1.7	Trash Percentage Evaluation Form

References

Appendices

Los Angeles Regional Water Quality Control Board Resolution No. R4-2007-010 and Basin Plan Amendment for Legg Lake Trash TMDL	A
Full Capture Certification for Catch Basin Inserts	B
Graphic Depiction of Nonpoint Monitoring Plan Improvements	C
TMRP Responsibility Matrices	D
Jurisdiction Resolutions/Approvals of the Legg Lake TMRP	E

Executive Summary

In response to Resolution No. R4-2007-010 of the Los Angeles Regional Water Quality Control Board (Regional Board), the Cities of South El Monte and El Monte, the State of California Department of Transportation (Caltrans), and Los Angeles County (County) have worked collaboratively to develop the following Trash Monitoring and Reporting Plan (TMRP) for Legg Lake.

This combined TMRP represents each responsible jurisdiction's implementation strategies for their point sources and a collaborative monitoring and reporting program strategy for non-point sources. The responsibilities of each jurisdiction with respect to their various TMRP's is attached as Appendix D.

In addition, this document shall serve as notice of our intent to comply with the Minimum Frequency of Assessment and Collection Program (MFAC).

Section 1 – An Overview

§1.1 Introduction

This TMRP has been prepared in response to Resolution No. R4-2007-010 of the Regional Board, attached as Appendix A, herein. Resolution No. R4-2007-010 amends the Water Quality Control Plan for the Los Angeles Region (Basin Plan) to incorporate the elements of a Total Maximum Daily Load (TMDL) for trash.

Legg Lake is located within the Whittier Narrows Recreation Area in the San Gabriel River Watershed. Whittier Narrows Recreation Area is bordered by the unincorporated County area and a number of cities including South El Monte, Pico Rivera, Montebello, Industry, and Rosemead. The 75-acre lake has approximately 22,000 linear feet of shoreline and is used for various recreational activities. The Basin Plan designates Legg Lake for beneficial uses associated with:

- Water Contact Recreation (REC-1)
- Non-contact Water Recreation (REC-2)
- Warm Freshwater Habitat (WARM)
- Cold Freshwater Habitat (COLD)
- Wildlife Habitat (WILD)
- Wetland Habitat (WET)

The Basin Plan also identifies Legg Lake for potential beneficial use for municipal and domestic supply (MUN). This potential benefit may not be applicable pending a future court decision.

Legg Lake is made up of three connected water bodies located within the Whittier Narrows Recreation Area. Through a lease agreement with the United States Army Corps of Engineers (Corps), the County is responsible for the day-to-day operation of the park and maintenance of the grounds and recreational amenities.

Legg Lake also serves as a flood retention basin for urban and storm water runoff from the flood control system. Most of the drainage to Legg Lake is conveyed via Bond Issue Drains 1213 and 529, with remaining runoff conveyed by a number of other smaller storm drains. The lake is regularly supplied with potable water and receives treated groundwater discharged by the San Gabriel Basin Water Quality Authority. Potable water is provided to operate two man-made waterfalls on the perimeter of the lake. Overflow from Legg Lake is conveyed to the Rio Hondo via Mission Creek through two outlets. The larger of the two outlets is located on the west side of the center lake while the smaller is located adjacent to the outlet of Bond Issue Drain 529. These sites are shown on Figures 1.2 and 1.3.

§1.2 Regulatory Background

The Federal Clean Water Act of 1972 requires states to develop a list of impaired waters and identify the pollutants for which they are impaired, also known as the 303(d) List. For each impaired water body, States must establish a watershed-based pollutant-specific TMDL that will bring impaired water bodies into compliance with the water quality standards necessary for achieving designated beneficial uses of the water body. Legg Lake is listed by the State of California as impaired under Section 303(d) of the Federal Clean Water Act for the following water quality parameters: ammonia, copper, lead, odors, pH, and trash.

On June 7, 2007 the Regional Board adopted an amendment to the Basin Plan incorporating a TMDL for Trash in Legg Lake (Appendix A). Approximately nine months later following required approvals by the State Water Resources Board, the Office of Administrative Law, and the U.S. Environmental Protection Agency, Stakeholders and Responsible Jurisdictions under the Legg Lake Trash TMDL were notified via memorandum that the effective date of the Legg Lake Trash TMDL as March 6, 2008. The memorandum further stated that based on said effective date responsible jurisdictions shall submit TMRP for review by the Regional Board Executive Officer no later than September 6, 2008.

§1.3 TMDL Provisions

Potential sources of trash in Legg Lake are categorized either as point sources or non-point sources depending on the mechanism of transport to the lake. Storm drains that convey trash to the lake are considered point sources because the trash is deposited into the lake at a clearly identifiable point, i.e., the storm drain outfall. Non-point sources may result in the deposition of trash into the lake via a variety of mechanisms including: wind blown trash from recreational and other land use areas in the immediate vicinity of the lake, scattering by vectors such as birds, conveyance via sheet flow during rain events, or direct dumping or littering into the lake. Both point sources and non-point sources are identified as sources of trash in Legg Lake.

The Legg Lake Trash TMDL is based on the establishment of numeric targets, WLAs for point sources, and Load Allocations for non-point sources, margin of safety, and implementation and compliance schedules for responsible agencies.

§1.3.1 Load Allocations

The County, as the jurisdiction responsible for the operation of Whittier Narrows Recreation Area, including Legg Lake, is assigned Load Allocations under the Legg Lake Trash TMDL. In addition, while not assigned Load Allocations in the Legg Lake Trash TMDL, both Caltrans and the City of South El Monte have agreed to take part in the MFAC program.

The Legg Lake Trash TMDL specifies that jurisdictions may achieve compliance with Load Allocations by implementing a MFAC in conjunction with a suite of Best Management Practices (BMP's), also known as a MFAC/BMP program approved by the Executive Officer of the Regional Board. The MFAC/BMP Program is to include a TMRP with the results and report of the TMRP to be submitted to the Regional Board on an annual basis. Based on the results of TMRP evaluation of effectiveness of the MFAC/BMP programs, the Regional Board is to reconsider the Legg Lake Trash TMDL five years from the effective date.

§1.3.2 Waste Load Allocations

Jurisdictions with land use responsibility for areas that drain to Legg Lake via the storm drain system are assigned WLAs under the Legg Lake Trash TMDL; these jurisdictions include: Caltrans, the County, the Los Angeles County Flood Control District, and the Cities of El Monte, and South El Monte.

The Legg Lake Trash TMDL states that if point source dischargers comply with the WLAs by implementing a full capture system certified by the Regional Board Executive Officer on conveyances that discharge to Legg Lake through a progressive implementation schedule, they will be deemed in compliance with the WLA. A full

capture system is any device or series of devices that traps all particles retained by a 5 millimeter mesh screen and has a design treatment capacity of not less than the peak flow rate resulting from a one-year, one-hour storm in the sub drainage area. Responsible jurisdictions that choose to comply via a full capture system must demonstrate a phased implementation of full capture devices over an 8-year period until the final WLA of zero is attained. Beginning four years from the effective date of the TMDL, full capture systems must achieve 20 percent reduction of trash from Baseline WLA, with 40 percent reduction in five years, 60 percent in six years, 80 percent in seven years and 100 percent in eight years. Compliance with the percent reduction from the Baseline WLA is to be assumed wherever full capture systems are installed in corresponding percentages of the conveyance discharging to Legg Lake with installation to be prioritized based on the greatest point source loadings. Zero will be deemed to have been met if full capture systems have been installed on all conveyances discharging to Legg Lake.

Responsible jurisdictions may alternatively comply with WLAs by implementing an MFAC/BMP program approved by the Executive Officer. MFAC protocols may be based on Surface Water Ambient Monitoring Program (SWAMP) protocols for rapid trash assessment, or alternative protocols proposed by dischargers and approved by the Executive Officer. Based on the results of TMRP evaluation of effectiveness of the MFAC/BMP programs, the Regional Board is to reconsider the Legg Lake Trash TMDL five years from the effective date.

Finally, the TMDL states that irrespective of whether the point sources employ a full capture system, they may comply with the WLA in any lawful manner.

§1.3.3 Numeric Targets

The narrative water quality objectives in the Basin Plan for floating material and solid, suspended or settleable materials are stated as:

“Waters shall not contain floating materials, including solids, liquids, foams, and scum, in concentrations that cause nuisance or adversely affect beneficial uses.”

“Waters shall not contain suspended or settleable material in concentrations that cause nuisance or adversely affect beneficial uses.”

In establishing the numeric targets for the Legg Lake Trash TMDL (Appendix A), the Regional Board interpreted/translated these narrative objectives into a numeric standard of zero (0) trash in Legg Lake and on the shoreline and stating that “zero is a conservative numeric target which contains an implicit margin of safety.” Zero trash is defined in the TMDL as:

- For non-point sources, no trash immediately following each assessment and collection event consistent with an established MFAC. The MFAC Program is established at an interval that prevents trash from accumulating in deleterious amounts that cause nuisance or adversely affect beneficial uses between collections; or
- For point sources, zero trash discharged into Legg Lake and its shoreline.

§1.4 Monitoring and Reporting Plan Development

The Legg Lake TMDL requires that responsible jurisdictions develop a TMRP that describes the methodologies that will be used to assess and monitor trash in Legg Lake and/or within responsible jurisdictions' land use areas. Responsible Jurisdictions implementing a full capture system and those implementing an MFAC program are both required to submit a TMRP within six months of the effective date of the TMDL as specified in Table 7-27.2a Legg Lake Trash TMDL: Implementation Schedule full capture system and Table 7-27.2b Implementation Schedule MFAC Program. Table 7-27.1 Legg Lake Trash TMDL: Elements, lists a number of elements to be included in the TRMP, including:

- A plan to establish the trash Baseline WLAs for non-Caltrans entities
- An alternative to the default trash baseline for Caltrans which is 6,677.4 gallons per square mile per year
- Assessment and quantification of trash collected from the surfaces and shoreline of Legg Lake or from responsible jurisdiction land areas
- A prioritization of areas that have the highest trash generation rates giving preference to this prioritization when scheduling the installation of full capture devices, BMP's or trash collection programs
- An evaluation of the effectiveness of the MFAC/BMP program and a revised MFAC

Additionally, according to Table 7-27.2a Legg Lake Trash TMDL responsible jurisdictions implementing full capture systems are to submit results of the TMRP,

recommend trash baseline WLA and propose full capture system prioritizations within two years of receiving approval of the TMRP.

Data collected in the County's previous study for trash generation rates based on land use as discussed in Section 2 will be utilized for prioritization of full capture devices.

The Legg Lake Trash TMDL states that responsible jurisdictions may coordinate their TMRP activities for Legg Lake, and all of the responsible jurisdictions have chosen to do so. This TMRP is the result of that coordination.

Section 2 of this TMRP describes the overarching trash monitoring and reporting considerations applicable to jurisdictions responsible for point source discharges to the lake, including an existing trash generation rate study. Then each responsible jurisdiction which has been assigned a WLA under the Legg Lake Trash TMDL has provided a description of their implementation strategy for compliance.

Section 3 of the TMRP describes the monitoring and reporting considerations applicable to non-point sources of trash in the lake and describes the MFAC/BMP Program to be implemented for non-point sources and the lake.

§1.5 Major Rainfall Event Definition

One of the requirements of Resolution No. R4-2007-010 is to define a major rainfall event for the Legg Lake watershed. When the County submitted its certification for full capture devices it provided the equation $Q = C \times I \times A$ to determine a major rainfall event. The equation simply states that a major rainfall event is defined as the most probable rainfall, within the Legg Lake watershed, resulting from a one-year, one-hour storm.

Section 2 - Point Sources

§2.1 Existing Trash Generation Study

A trash generation study was conducted in the past by the County to address requirements for other Trash TMDLs within the Los Angeles Region. The study provides the necessary guidance to effectively implement the necessary measures to comply with the Legg Lake TMDL requirements. Additional studies will not be necessary and their costs could be better applied towards the implementation efforts. The County study resulted in the prioritization of land use areas within the LA River and Ballona Creek watersheds based on their trash collection rates. That study will be used to develop the implementation strategy for the Legg Lake watershed.

The study will guide the appropriate selection of the structural trash control measures to achieve compliance and will also point out that targeting a particular land use first would be more beneficial than another to achieve a greater rate of trash reduction. A brief synopsis of the purpose of the study, method of data collection, and resultant conclusion is provided below. The completed study and data were submitted to the Regional Board on February 17, 2004. If needed, a copy can be provided upon request.

§2.2 Synopsis of Existing Trash Generation Study

The County of Los Angeles Department of Public Works conducted trash data collection activities from October 15, 2002 to February 3, 2004 in response to the Los Angeles River and Ballona Creek Trash TMDL. The intent of the study was to collect data throughout the County catch basins (CBs) to supplement the one data point

referenced in the LA River and Ballona Creek Trash TMDL. Consequently, at the conclusion of the data collection period the data provided information as to the different land uses and their trash collection trash amounts. The study generalized the two watersheds into five land use categories: high density single family residential (HDSFR), low density single family residential (LDSFR), commercial, industrial, and open space.

The study consisted of retrofitting CBs with basket inserts and installation of hydrodynamic devices downstream of the CBs catchment area to determine the amount of trash collected in that area. A total of 500 CBs were retrofitted with CB basket inserts and were equally distributed among the two watersheds. Each of the land use areas in the watersheds had CBs retrofitted and had a hydrodynamic device installed, for a total of 5 in the two watersheds.

The trash data collection was triggered by storm events having an accumulation 0.25 inches and a predetermined span between storms during the wet season and a set interval during the dry season. Trash collection consisted of manual (man-entry) cleaning of each insert found within the CB as well as mechanical cleaning of the hydrodynamic devices. The trash collected was further manually sorted into man-made trash and vegetation, on site, and a volume (gallons) and mass (pounds) determined for each CB.

For the Los Angeles River watershed, the highest amount of litter generation (per unit area) was observed in the industrial land-use followed by commercial land-use. For Ballona Creek watershed, commercial land-use was found to be the single major generator of litter (per unit area). It was also determined that open space/parks land-use

generated the most sediment/vegetation for both watersheds followed by the low-density single-family residential land-use.

The County study concluded that commercial industrial land-uses should be the priorities when initiating trash reduction measures. The study showed that most of the trash will be consistently collected in these land uses.

§2.3 Implementation Strategies

There are approximately 150 CBs that collect urban and storm runoff and discharge to Legg Lake through the Los Angeles County Flood Control District's BI drains 1213 and 529. The area tributary to these catch basins is within the jurisdictional boundaries of the Cities of El Monte and South El Monte. Their current efforts and proposed strategies are included below. Additionally, Caltrans maintains and operates the Pomona Freeway (State Route LA-60) and Rosemead Boulevard (State Route LA-164) which bisect the watershed of Legg Lake.

In addition to the two major storm drains that drain into Legg Lake, there are several other smaller drains, roughly 4 to 6 inch PVC drains, or "French Drains" that drain any nuisance collection of irrigation water from low lying areas around the park. Through small grated inlets at low points in the park's topography water is conveyed to the lakes shoreline. As part of the daily park maintenance around the lake, the County will collect and incorporate the accumulated trash at the grated CBs to the amount of trash collected around the lake.

§2.3.1 City of South El Monte

Current Efforts

South El Monte is directly adjacent to the Legg Lake, and it has a major interest in the protection and preservation of this important recreational area and biological habitat. The City has instituted many BMP's and programs designed to address runoff to the area and to educate the public on improving Stormwater quality and dry water diversion runoff. Below is a list of these BMP's and programs organized into three main groupings: technical, educational, and institutional controls.

Technical

- All sheltered transit stops are equipped with trash receptacles.
- The City has about 63 CBs, which drain into storm drainage lines that empty into Legg Lake; the City has prioritized these CBs for installing partial capture inserts or covers, and at present about 50% of the CBs have been retrofitted.
- The retrofit of the remaining prioritized CBs is scheduled to be completed prior to the end of 2008.
- All CBs are cleaned at least once a year, with "Priority A" CBs cleaned at least 3 times a year, and "priority B" CBs cleaned at least twice a year.
- City code enforcement routinely patrols the area adjacent to Legg Lake to enforce the City's anti-litter and illegal dumping laws.
- City crews routinely collect debris and trash that occurs before or after the regular street sweeping on the streets leading to and from Legg Lake Recreational area north of State Route LA-60.

Institutional Controls

- Development planning and development construction requirements for Stormwater pollution prevention are in-place as required by the City's municipal code and its NPDES permit.
- Enforcement of litter laws is a high priority with Code Enforcement to reduce the pollutants in Stormwater.
- Frequent street sweeping (once a week in all areas and twice a week in the areas of concern (high incidence of trash or other debris).
- All refuse bins are required by City ordinance to be maintained with their lids closed at all times.
- City code enforcement and the City's consultant have been regularly monitoring the industrial area adjacent to Legg Lake north of State Route LA-60 for illegal dumping and littering activities.

Educational Program

- CB stenciling is performed annually.
- Educational materials regarding storm water pollution prevention have been distributed at citywide events, concerts in the park, and other programs.
- A series of eight BMP's brochures, recycling and antilitter handouts, and other materials are displayed prominently at City Hall, and they are routinely distributed to the public at City counters for Code Enforcement, Public Works, Engineering, and Planning.

- Outreach materials are provided to all developers at the City Planning Counter and are made available at pre-construction meetings as part of Plan check reviews for all new projects.
- Street Banner along Santa Anita - a 2-sided banner will be stretched across the street informing drivers of the campaign and the need to end littering during this summer.
- School Assemblies - students will be educated about litter problems from Earth Day (April 22) and to continue into Fall 08 and beyond through school assemblies.
- The City has identified key littering zones and has targeted outreach to potentially responsible parties; this outreach consists of a door hanger explaining the issue of storm water pollution prevention, and informing the PRP that further littering and dumping shall result in fines and other penalties.
- Articles have been published in the local newspapers identifying the problem and promoting solutions - the first two articles were published in April and May 2008.
- The City has established an award program to reward "clean neighbors" - residents and businesses will be feted at city council.
- Website information – The City has added information on the website about litter, recycling and storm water.
- The City has established a select committee to address littering and storm water pollution prevention as a key component of community beautification and improvement.

- The City has been giving away reusable bags as a reminder to stop littering and reduce the use of plastic bags which are among the most visible constituents of litter.

Proposed Program

This TMRP has been prepared by the City of South El Monte as a supplemental submission to the integrated TMRP for Legg Lake for the members of the Jurisdictional Group including the Cities of El Monte and South El Monte, Caltrans, and the County (the Group).

Legg Lake is a 75-acre man-made water body originally constructed for the safe and efficient retention of run-off from storm and other related events. It serves as a recreational lake and it receives daily dry weather diversion from both within and outside the park, discharge from two wells within the park, and discharge of treated water from an adjacent superfund site. It has become a habitat for wild life as well, and many people fish in the lake for recreation and food consumption. The Lake and park are directly adjacent to South El Monte, and water enters the Lake from two different origins:

- North Lake Area – non-piped drainage (*overland flow*) via public roads (i.e., Chico, Adelia, and Potrero Streets) to the park area north of the State Route LA-60, then conveyed by box drains under the freeway to Legg Lake; and
- South Lake Area – direct drainage via catch basins along Santa Anita and other streets in South El Monte, proceeding underground through drainage pipes, and emanating from two storm drain outlets south of the State Route LA-60 (i.e., BI1213 and 529, which are shared by South El Monte and El Monte).

The latter is a defined “point source” comprised of about 63 CBs operated by South El Monte that drain directly into the Lake system, and for which South El Monte has recently installed screens and covers to control introduction of trash into the lake. The former is a “non-point source” which is more difficult to quantify and control, but for which South El Monte and the County are planning to install structural and treatment BMP’s as well as implement significantly enhanced institutional controls.

Monitoring Plan Development

The purpose of the South El Monte monitoring plan will be to determine a baseline allocation for trash emanating from South El Monte’s jurisdiction. The monitoring plan will also be utilized as a measure of the city’s performance. The Regional Board has determined that an annual 20% reduction of trash is feasible. In order to meet these annual reductions, South El Monte is required to increase the effectiveness of its current strategies.

The development of an all-encompassing monitoring plan is difficult, so while the Group has determined that it will develop and submit both point and non-point TMRP in a single document to the Regional Board, South El Monte as well as other responsible parties, will submit their point source plan and collaborate with other responsible parties to develop the non-point plan.

Point Sources

There are about 63 CBs located in the City of South El Monte that the city is responsible for in terms of controlling the introduction of non storm water discharges including trash. Each one of these CBs will be a collection point for not only trash, but also data. Data will consist of the following:

- Collected materials captured by screens and covers on each of the CBs,
- Weekly street sweeping weights and composition, and
- Daily observation through the use of photographic evidence and personal notation

During weekly cleanings of the CBs, South El Monte will remove the trash collected on the screens/covers and report the weight collected in order to develop a baseline quantity. This weekly collection will continue for two years with the average of the weights during the two years to become the base line trash level for South El Monte. As part of this duty, South El Monte staff will be obligated to obtain weekly photographic analysis of the condition and operation of each location, including close up photography of any entrained trash prior to collection. Also, South El Monte staff will use the form identified as Figure 1.6, herein, to detail information on the week's weather, events, etc., and the condition of the CB screen/cover devices.

Street sweeping will be coordinated in such a way that the areas constituting the watershed for Legg Lake shall be swept and the contents measured by weighing, photographic composition, and hand sort analysis. Weight records will be kept weekly, but compositional analysis shall only be performed semi annually, during the wet season and during the dry season for comparison purposes. Survey forms and weekly photographs of each CB shall be completed, and the evidence maintained for submittal to the Regional Board in the annual report.

The data collected from the weekly monitoring shall be compiled to establish a baseline trash allocation and to determine the performance of South El Monte to reduce

trash levels by 20% annually. The annual report shall consist of the following as a minimum:

- Previous year's collected trash volume in pounds and tons with any associated dump tickets
- Photographic evidence and completed surveys organized on a weekly basis
- Maintenance and operation routines from trash collection operations and documentation of any needed repairs to the fence filter devices
- Any efforts or improvements not included in the monitoring/implementation plans to curtail trash deposition at the lake
- Schedule of the monitoring/implementation plan improvements progress
- Report of progress towards meeting the trash reduction goal
- Improvement and programs implemented within that reporting year

§2.3.2 City of El Monte

Current Efforts

The City of El Monte has implemented many BMP's and has developed several public information and awareness campaigns. The City's ongoing activities include:

- Implementation of existing institutional controls such as development planning and development construction requirements;
- Enforcement of litter laws to reduce the pollutants in the stormwater;
- Intensive street sweeping: Mountain View Road and Peck Road are swept twice per week; all other residential streets, which may also potentially contribute to Legg Lake trash accumulations, are swept once per week; municipal parking lots are cleaned three times per week;

- Catch basins cleaning as required by the NPDES permit Order No. 01-182: "Priority A" catch basins at least 3 times a year, "priority B" catch basins at least 2 times per year and "priority C" basins once per year;
- Annual catch basin stenciling;
- Catch basin retrofitting: while ownership of storm drain infrastructure within the City of El Monte is split between the City and the Los Angeles County Flood Control District, the City records indicate that there are four priority "A" and three priority "B" catch basins, the remainder being priority "C." Six out of the seven priority "A" and "B" outlets have been equipped with automatic retractable screens or filter basket inserts.
- All sheltered transit stops are equipped with trash receptacles.
- Educational materials regarding stormwater pollution prevention have been distributed at citywide events, i.e. Billion Bottle March and other recycling events;
- Establishment of a city reporting hotline in addition to the advertising of the County's 888-CLEAN-LA hotline;
- A series of eight best management practices brochures, and recycling and anti-litter handouts are available at the City Code Enforcement, Community Services, Public Works Engineering and Maintenance counters.
- Outreach materials are provided at pre-construction meetings to developers and contractors, as part of the City's Public Works requirements for new projects;

- Outreach letters are annually mailed to all restaurant and commercial complexes;
- The City's standard "Construction Site Letter" is distributed to construction site supervisors and/or foremen by the City Building Inspectors, before the start of the rainy season;
- The City has intensified its efforts to educate youth on storm water pollution and has teamed up with Los Angeles County and Amigos De Los Rios to provide informative materials about protecting the environment.
- The City's website offers improved information on stormwater pollution prevention, litter, and recycling.

Proposed Program

This TMRP has been prepared by the City of El Monte to address point source contributions to Legg Lake.

The El Monte tributary area to the lake is 0.11 square miles, or 7% of Legg Lake Watershed. It includes residential and commercial sites located along Mountain View Road, from Garvey Avenue to the South city limits. The runoff is collected by twenty catch basins owned by the City and nineteen County-owned catch basins, and discharged into the lake at the Bond Issue 529 outfall.

The City will accept the existing trash generation study conducted by the County of Los Angeles, and the Baseline WLA of 509.48 gallons of trash per year assigned to El Monte by the Regional Board.

For point source implementation, the El Monte City Council has approved the installation of Regional Board Certified full capture devices in all thirty-nine catch basins

located within city limits and draining to Legg Lake. The City will annually report the implementation progress to the Regional Board, as required.

§2.3.3 The State of California Department of Transportation

Current Efforts

Caltrans maintains and operates the State Route LA-60 and the State Route LA-164 which both bisect the watershed of Legg Lake. To combat trash both within Caltrans right of ways and that which will ultimately make its way in to Legg Lake, Caltrans has established the following procedures to curtail the trash along its right-of-ways:

- Litter removal along road rights of ways twice a month.
- Right shoulders and center median are swept twice a month.
- As of June 2008, litter removal on State Route LA-60 will be conducted on a weekly basis.
- An on going Adopt-a- Highway available to the public
- An on going Public Education and Outreach Campaign – “Don’t Trash California”

Proposed Program

This TMRP has been prepared by Caltrans to address point source contributions to Legg Lake.

Wasteload Allocation

Caltrans is listed as a point source agency. The WLA assigned to Caltrans is 586.92 gallons per year based on the Caltrans Litter Management Pilot Study (LMPS).

Even though the LMPS was not intended for establishing a trash generation rate for the State Routes and related facilities, however Caltrans will accept this WLA at this time for the purpose of this TMDL until better data are developed in the future.

Compliance Strategies

Caltrans is identified as a point source agency in the TMDL. However, Caltrans may elect to implement full capture devices and institutional programs including a public education and outreach program, as well as participating in a MFAC to achieve the TMDL goals.

Point Source Approach

For point source implementation, Caltrans may retrofit Gross Solid Removal Devices (GSRD) or other full capture devices along State Route LA-60 at locations where feasible.

The GSRDs developed by Caltrans have been certified as full capture devices by the Regional Board. Several other Caltrans storm water treatment BMP's such as infiltration basins, detention basins, and media filters are currently being processed for full capture certification. Where site conditions permit, GSRDs and other full capture BMP's may be placed at the existing storm drain outfall locations.

Section 3 – Non-point Sources

Although the County was the only agency to receive a Load Allocation in the Legg Lake Trash TMDL for Non-Point Sources, subsequent field evaluations of Legg Lake revealed that both Caltrans and the City of South El Monte also have some non-point source trash that enters into the lake. Development of the TMRP for non-point sources was divided up geographically into two areas, the area surrounding the lake and the lake/shoreline.

§3.1 Non-point Source Monitoring Plan

Surrounding Lake Area

This portion of the non-point source monitoring plan was developed by a Technical Advisory Committee (TAC) made up of members representing the City of South El Monte, Caltrans, and the County. The major component of the monitoring plan is a device that will collect trash at critical areas between jurisdictional boundaries. The device, is a modified chain link fence and filter screen that will capture trash at those areas where geographical and man-made structures have concentrated the storm flows and trash carried by those flows. Several design drawings of these “fence/filter” BMP’s are found in Figures 1.4A and 1.4B. The “fence/filter(s)” are to be installed at jurisdictional boundaries. Each “fence/filter” will be strategically located to capture trash carried by runoff from each Jurisdiction.

Responsibility for the maintenance and operation of the “fence/filter(s)” lies with the jurisdiction upstream of the device. Maintenance and operation of the “fence/filter” includes its initial construction and weekly removal of the trash. Additional maintenance

may include repairs due to vandalism, as-needed trash removals, or other unforeseen acts. A total of ten “fence/filter(s)” have been proposed. A layout of the proposed improvements under this TMRP is attached in Figure 1.5, herein. The City of South El Monte and Caltrans will be responsible for a total of four “fence/filters” each; the remaining two will be under the jurisdiction of the County. The Jurisdictions have agreed to weekly monitoring/cleanings of the devices, and when necessary, the opening of a bypass grate, during heavy storm flows, but after the first flush has occurred.

During the weekly cleanings, the responsible jurisdiction will remove the trash collected within the “fence/filter(s)” and report that tonnage, or volume in order to develop a baseline trash measurement. This weekly collection will continue for two years, with the average measurement of those two years becoming the baseline trash level for each jurisdiction.

Lake and Shoreline

Legg Lake has a surface area of approximately 75 acres, and is made up of three water bodies. There is also approximately 22,000 linear feet of combined shoreline between all three of the lakes which make up Legg Lake. As noted in the MFAC, the County currently skims the lake surface for trash weekly and collects trash along the shoreline daily. This is done both with a boat and a multi-man crew utilizing modified hand tools to corral the trash on the lake and along the shoreline for pick-up and disposal.

The collected material includes both vegetation and trash. In order to accurately measure the amount of trash collected without having to manually separate the trash and vegetation, the County proposes a system of rapid trash assessment. In order to

quantify only the trash's value we are proposing to utilize the experienced field staff who regularly pick up the trash, to estimate the percentage of trash versus vegetative material. These staff will complete a form estimating the percentage of the trash they collected from the Lake surface versus vegetative waste. These daily percentages will then be averaged and used to determine a composite of trash versus vegetation for the reported tonnages. A sample of the form is attached in Figure 1.7, herein.

In order to quantify the amount of trash along the lake surface and shoreline, the weekly and daily collection of trash will now be separated from other trash collected from the park and reported by both volume and tonnage. The County will conduct a rapid assessment of the trash by utilizing the average percentage calculated via the "Trash Percentage Evaluation Form" to provide the necessary tonnage to develop a baseline allocation.

In addition, the County will set up ten photographic evaluation sites at critical areas around the lakes shoreline including at the discharge points for BI 1213 and 529. These locations are also seen in figure 1.5, attached. Photos will be taken and a survey completed weekly, providing further information on the previous week's weather and events at the park. A sample of this form is attached in Figure 1.6, herein. This will help the County to determine where and when trash levels can be expected to be highest and provide guidance for developing strategies to reduce the amount of trash within the Lake generated from the surrounding park area.

Health and Safety Plan

Los Angeles County Parks & Recreation Staff have been conducting trash removal from Legg Lake for decades. The staff is currently well versed in the

procedures for collecting trash from both the lake surface and shoreline. The new procedures outlined in this section, weekly photo evaluations and trash percentage estimation, will be taught to existing and new personnel through training classes.

Current Los Angeles County Parks & Recreation safety protocols are adequate for the proposed MFAC and will remain as guidance for the field staff in the collection and disposal of the trash.

§3.2 Reporting Plan Development

The data collected from the weekly monitoring shall be compiled to establish a baseline trash allocation in the first two years and subsequently to determine the performance of each jurisdiction to reduce trash levels by 20 percent annually. The data will be compiled and presented annually to the Regional Board. At a minimum the annual report will include the following information:

- Previous year's collected trash volume in pounds and tons with any associated dump tickets.
- Photographic evidence and completed surveys organized on a weekly basis
- Forms and documents relating to the implementation of the TMRP.
- Maintenance and operation routines for trash collection operations and documentation of any necessary repairs to fence filter devices.
- Any efforts or improvements not included in the monitoring/implementation plans to curtail trash deposition at the lake.
- Schedule of the monitoring/implementation plan improvements progress.
- The improvements and programs implemented within that reporting year.

The annual development of the non-point source Reporting Plan will be a collaborative effort of all of the Jurisdictional Group's members. Each Jurisdiction will provide the data collected and an analysis of the year's activities in an annual report that will be submitted to the Regional Board. Those Jurisdictions with both point and non-point source contributions to Legg Lake will be required to keep two sets of data, tracking the progress of their non-point and point source efforts separately.

§3.3 Implementation Strategies

§3.3.1 City Of South El Monte

In fulfillment of its contribution to the integrated TMRP, South El Monte has developed the following list of preferred strategies for control of non-storm water discharges to Legg Lake. The measures include structural and institutional BMP's as well as extensive education and outreach.

Structural BMP's

In concert with the County and Caltrans, South El Monte shall construct fence filter devices along Chico , Adelia, and Potrero Avenues:

- Chico Avenue - to include one fence filter device;
- Adelia Avenue – to include one fence filter device and 30 linear ft of chain link fence; and
- Potrero Avenue – to include two fence filter devices

Institutional Control BMP's

South El Monte has implemented specific institutional controls including CB screens and covers (partial capture devices), enhanced street sweeping, and enhanced litter abatement:

- CB screens/covers in all 63 CBs located within the watershed of the Legg Lake that are within the City's jurisdiction;
- Enhanced street sweeping in the Legg Lake Watershed area (organized on need of the TMDL, not the convenience of the City, i.e., it has been found through site analysis that more litter is deposited at or near the Lake on the weekend or holidays, therefore, street sweeping should occur immediately after the weekend or holidays); and
- Enhanced litter abatement through increased ticketing and enforcement of littering laws not only on public right of ways but also on private property where such litter and debris can be easily blown into the streets by wind or water action

Education and Outreach Activities

South El Monte shall conduct extensive outreach and education to the public and business community through seminars, direct mail outreach, incentive programs, and education through established neighborhood and community organizations including the Chamber of Commerce, home owner associations, schools, and local environmental and consumer groups.

§3.3.2 County of Los Angeles

Current Efforts

The County of Los Angeles' jurisdiction includes the maintenance and operation of Legg Lake and the Whittier Narrows Recreation Area. The County has implemented numerous water quality BMP's within the Whittier Narrows Recreation Area including:

- Park staff collects trash along the perimeter of the Lake and shoreline daily.
- The surface area of the Lake is skimmed once per week. Grounds maintenance workers use a small pontoon boat and modified maintenance tools to gather and push the trash against the shoreline where additional crews pick-up and properly dispose of the waste.
- Litter is also collected from the hundreds of trash cans that surround Legg Lake and the Whittier Narrows Recreation Area.

Proposed Program

In addition to the aforementioned current efforts, the County proposes to reduce the trash within Legg Lake by:

- The posting of "no littering" signage within the Whittier Narrows Recreation Area and around the Lake itself. This will heighten the public's awareness of their effect on water quality.
- Providing additional public education including a possible "don't trash our lake" campaign which would be prominently displayed within the park at all facilities as well as shown on the sides of numerous trash cans within the recreation area.

- Increasing the frequency of street sweeping within the main parking lot, as well as park roadways, during major holidays and other park events.
- Conducting extensive photo monitoring of the Lake and “hotspot” areas, where regularly scheduled photos are taken at specific times of day.
- Establishing Lake trash pickup boundaries with Whittier Narrows’ staff to separate the Lake trash from Recreation Area generated trash.
- Creating and posting easily understood signage at trash enclosures as well as an education program for grounds maintenance workers regarding the separation of trash from different sources (i.e. lake and shoreline versus the rest of the park) and where to deposit each.
- Providing additional trash bins around the Lake’s perimeter, as well as making trash bags available to large groups of people that are close to the Lake’s shoreline.

§3.3.3 The State of California Department of Transportation

Caltrans will continue to remove trash within the State right-of ways by implementing institutional programs such as roadway sweeping, trash pickups, Adopt-a-Highway, etc. Caltrans continues to carry out a public education and outreach campaign – “Don’t Trash California”, and above of all will partner with County of Los Angeles in its MFAC.

Institutional Programs

Caltrans removes litter from the State Highway systems on a regular basis by implementing various programs such as court referral program, Adopt-a-Highway program, regular roadway maintenance by sweeping and drain inlet cleaning.

Rosemead Boulevard, State Route LA-164, is a conventional highway. The TMDL indicates that “major boulevards that are currently under Caltrans’ jurisdiction, but affected by trash generated on municipal sites will be addressed by the cities of concerned”. Caltrans will continue coordinating and working with the County and City of El Monte to address trash on Rosemead Boulevard.

Public Education and Outreach Program

Caltrans implements “Don’t Trash California” Campaign as a Statewide Litter Outreach Program to increase public awareness on impacts by littering. Trash reduction is projected by behavior changes reported in a survey of residents in the County.

Minimum Frequency and Collection Program

Caltrans intends to partner with the County to participate in the MFAC programs that are developed for the park area immediately adjacent to the Legg Lakes and those MFAC by the other Responsible Jurisdictions, and participate in the trash monitoring programs developed for the park area and other areas.



**Trash Monitoring & Reporting Plan:
Legg Lake Trash TMDL**

TABLES

TABLE 1 - Monitoring & Implementation Plan Schedule - Point Sources

Date	09/08/2008	12/2008	01/2009 to 06/2009	06/2009 to 06/2011	06/2012	06/2013	06/2014	06/2015	06/2016
Action	Submit TMRP to Regional Board	Anticipated Acceptance of TMRP by Regional Board	Construct Improvements recommended in TMRP	Two year monitoring period	20% reduction of established trash baseline	40% reduction of established trash baseline	60% reduction of established trash baseline	80% reduction of established trash baseline	100% reduction of established trash baseline

TABLE 2 - Implementation Schedule - MFAC Program

Date	09/08/2008	12/2008	01/2009 to 06/2009	03/08/2010 and annually thereafter	03/08/2013
Action	Submit Notice of Intent to Comply with Conditional Waiver of Discharge Requirements	Anticipated Acceptance of MFAC/BMP & TMRP by Regional Board	Implement MFAC/BMP Program	Submit annual TMRP reports including proposal for revising MFAC/BMP	Reconsideration of Trash TMDL based on the effectiveness of MFAC/BMP Program



**Trash Monitoring & Reporting Plan:
Legg Lake Trash TMDL**

FIGURES

FIGURE 1.1
LEGG LAKE WATERSHED



FIGURE 1.2
Legg Lake Vicinity Map

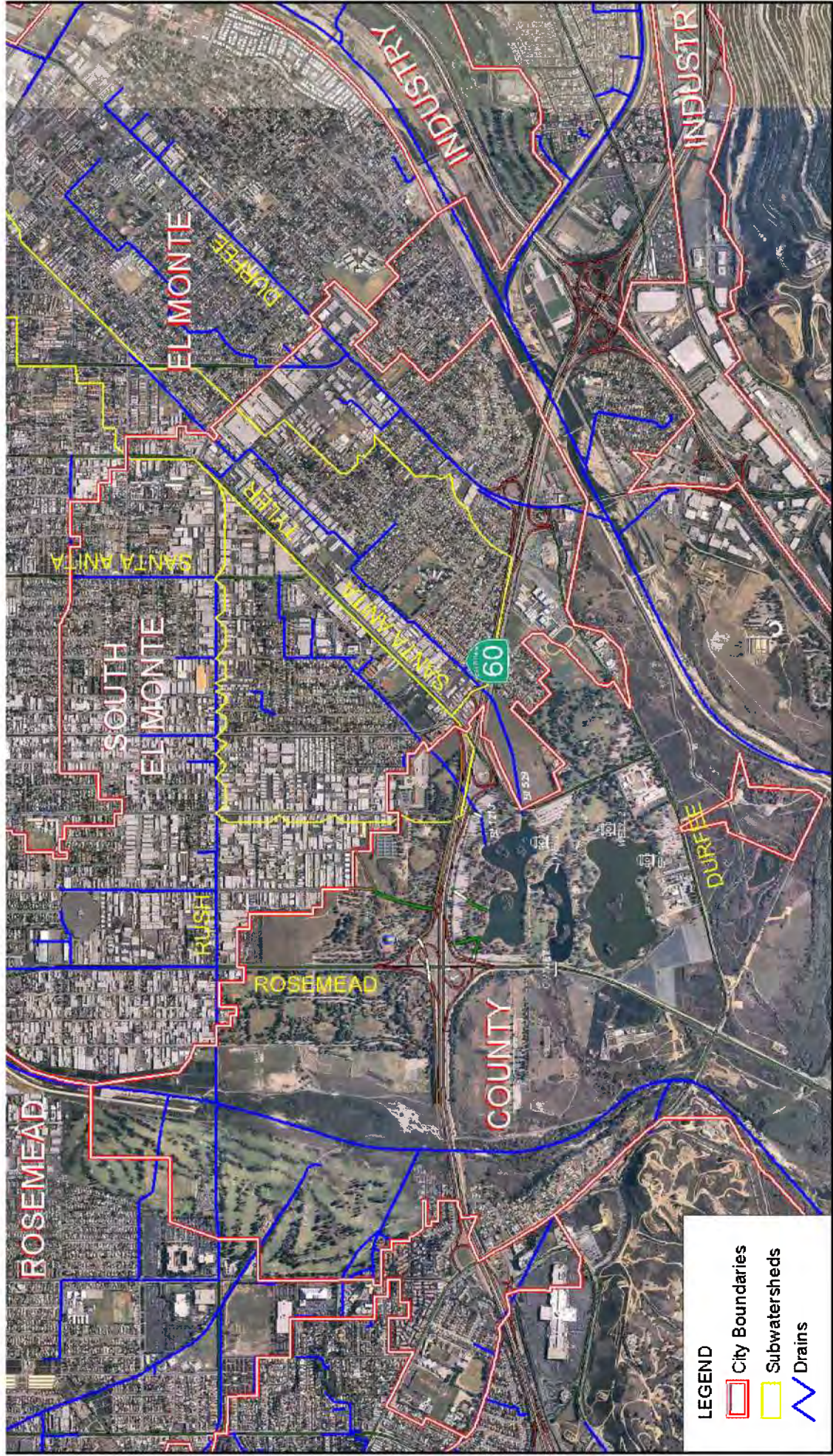

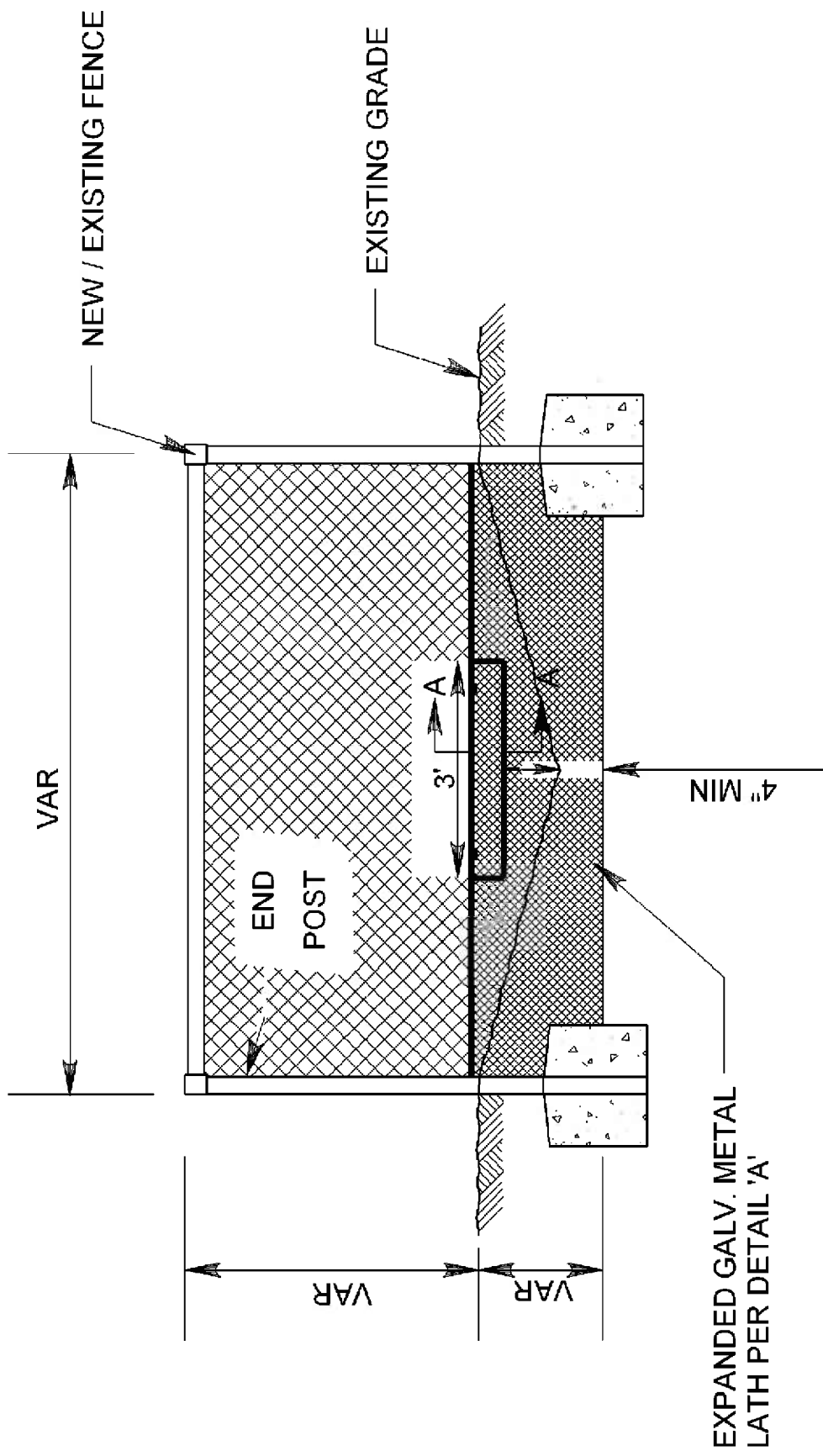

FENCE / FILTER TYPICAL SECTION
 AT VARIOUS LOCATIONS
 NOT TO SCALE

FIGURE 1.4A GRATED FENCE/FILTER DESIGN (1 OF 3)

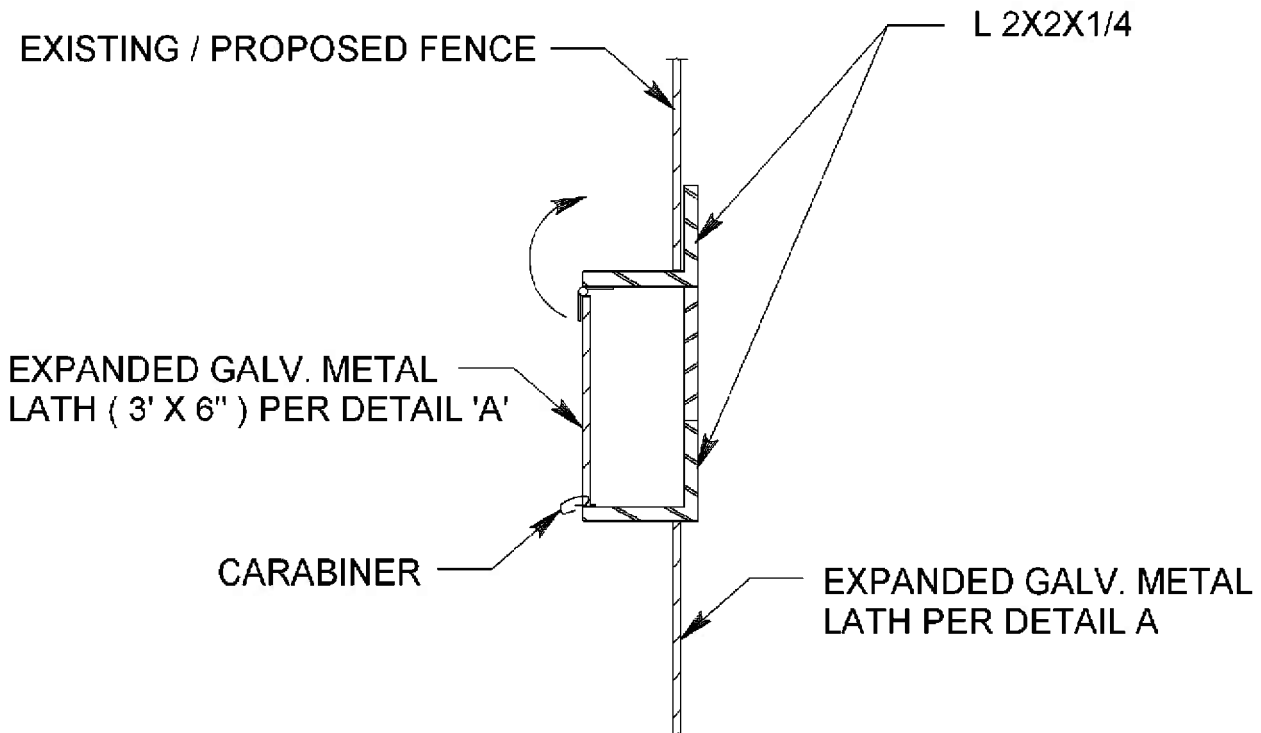

SECTION A-A
NOT TO SCALE

FIGURE 1.4A GRATED FENCE/FILTER DESIGN (2 OF 3)

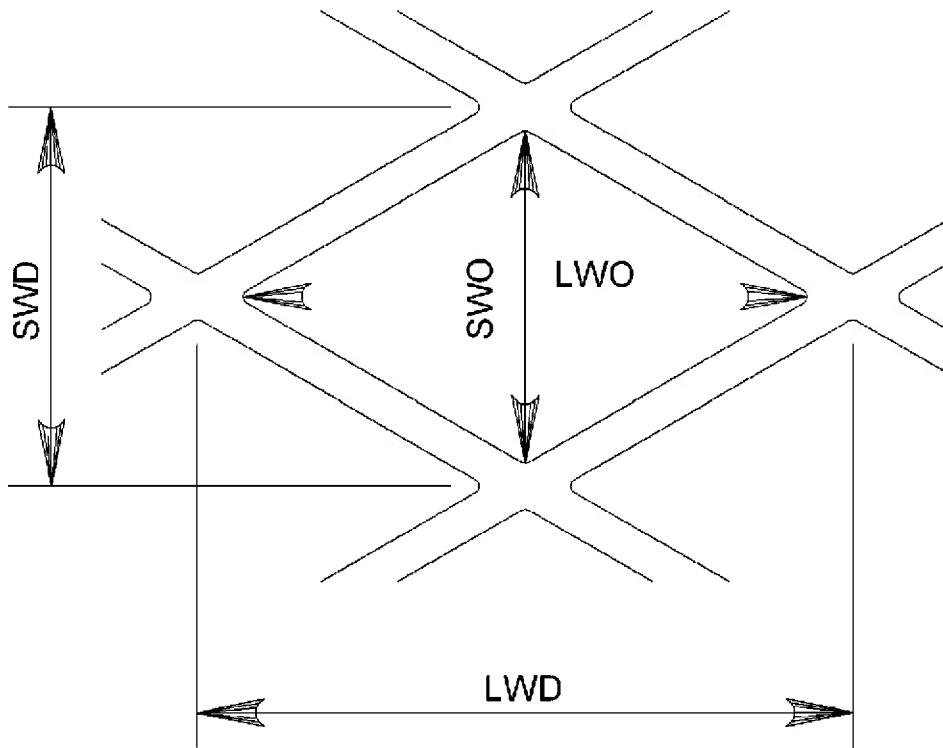

Galvanized Carbon Steel Expanded Metal - Flattened With Bond Shearing									
Style	Lbs. Per 100 Sq. Ft.	Design Size (Inches)		Opening Size (Inches)		Size Of Strands in (Inches)		Overall Thickness (Inches)	Percent Open Area
		SWD	LWD	SWO	LWO	Width	Thickness		
1/2" # 18	83	0.500	1.25	0.312	1.000	0.097	0.039	0.039	60.000

SWD - SHORT WAY OF DESIGN
 LWD - LONG WAY OF DESIGN

SWO - SHORT WAY OF OPENING
 LWO - LONG WAY OF OPENING

DETAIL 'A'
 NOT TO SCALE

FIGURE 1.4A GRATED FENCE/FILTER DESIGN (3 OF 3)

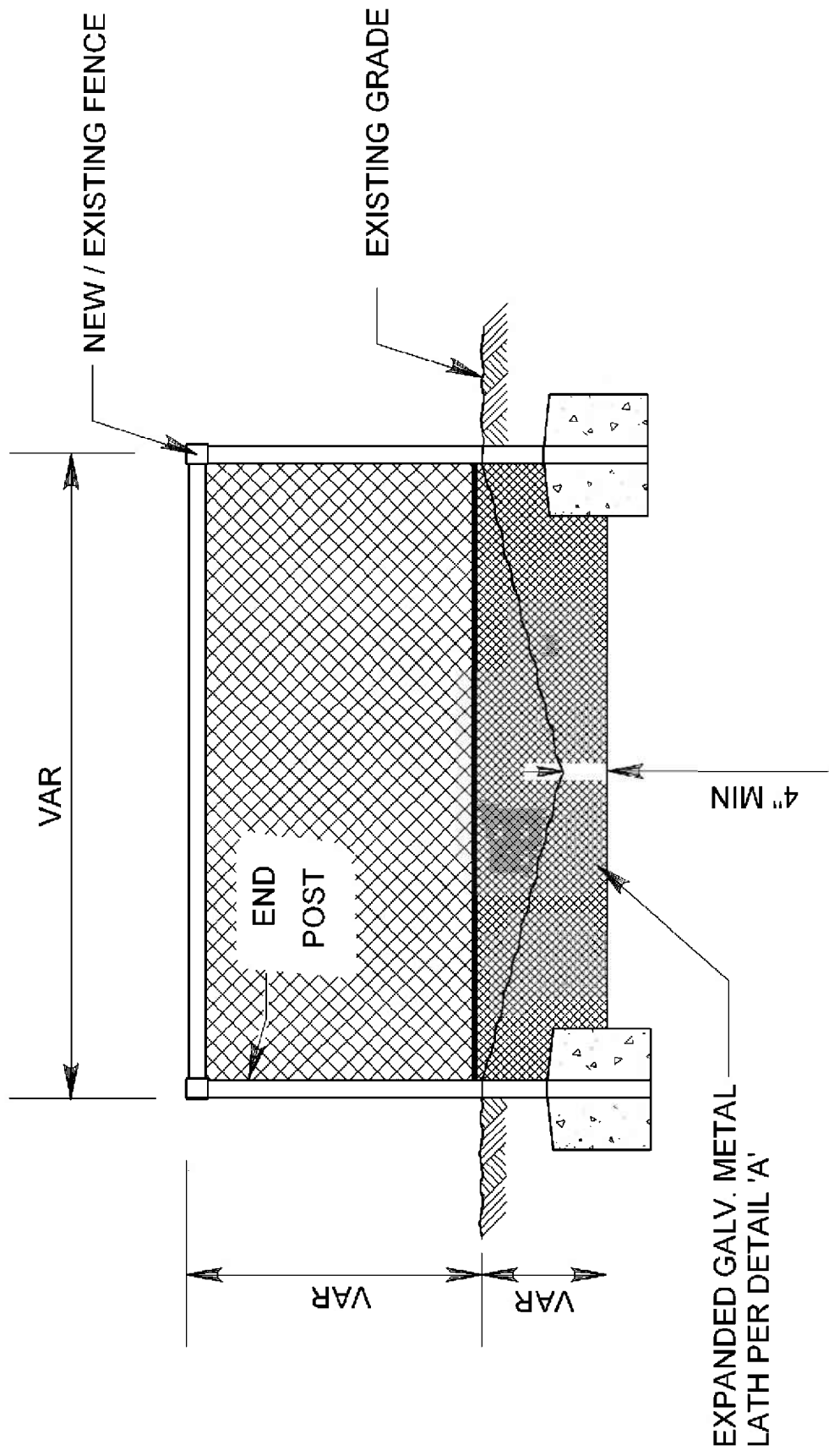

FENCE/FILTER TYPICAL SECTION
 AT VARIOUS LOCATIONS
 NOT TO SCALE

FIGURE 1.4B NON-GRATED FENCE/FILTER DESIGN (1 OF 2)

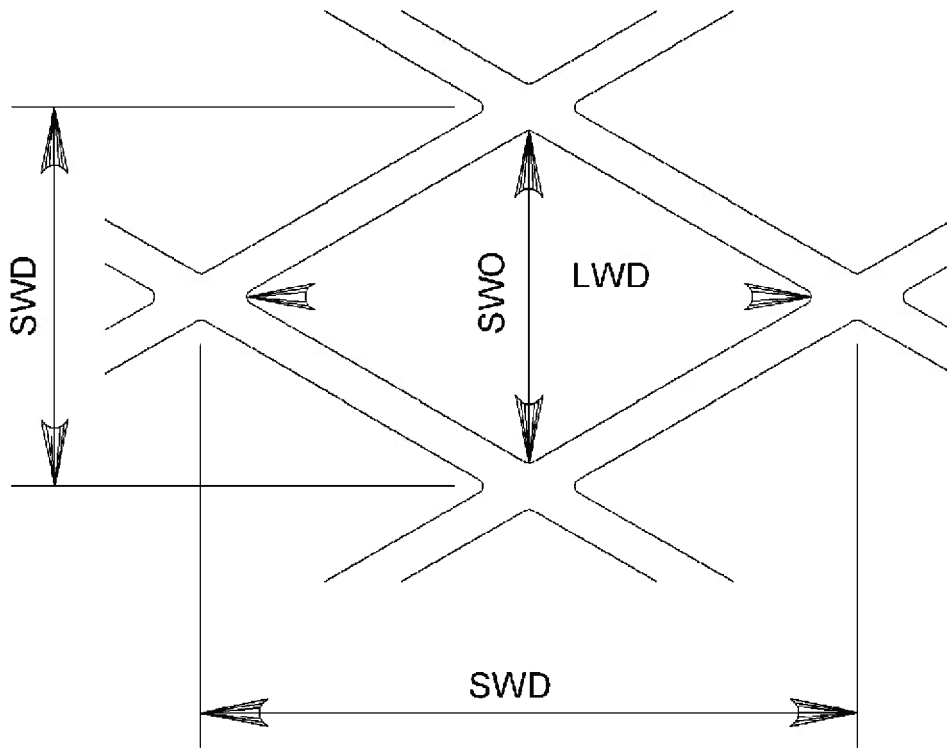

Galvanized Carbon Steel Expanded Metal - Flattened With Bond Shearing									
Style	Lbs. Per 100 Sq. Ft.	Design Size (Inches)		Opening Size (Inches)		Size Of Strands in (Inches)		Overall Thickness (Inches)	Percent Open Area
		SWD	LWD	SWO	LWO	Width	Thickness		
1/2" # 18	83	0.500	1.25	0.312	1.000	0.097	0.039	0.039	60.000

SWD - SHORT WAY OF DESIGN
 LWD - LONG WAY OF DESIGN

SWO - SHORT WAY OF OPENING
 LWO - LONG WAY OF OPENING

DETAIL 'A'
 NOT TO SCALE

FIGURE 1.4B NON-GRATED FENCE/FILTER DESIGN (2 OF 2)

FIGURE 1.5

Monitoring Plan, Proposed Improvements, and Photo Location Map



FIGURE 1.6

Legg Lake Photo Evaluation Weekly Survey

Date: _____

Name: _____

Day of the Week: _____

Previous Week's Weather

- W - Windy
- R - Rainy
- S - Sunny
- C - Cloudy

Day	S	M	T	W	T	F	S
Symbol(s)							

Event(s)

Date: _____ Type: _____

Date: _____ Type: _____

Date: _____ Type: _____

Photo File Name	Location	Photo File Name	Location
_____	1	_____	2
_____	3	_____	4
_____	5	_____	6
_____	7	_____	8
_____	9	_____	10

Comments: _____

FIGURE 1.7

Legg Lake Daily Trash Percentage Evaluation

Date: _____

Employee Name: _____

Day of the Week: _____

Weather:

Windy

Rainy

Sunny

Cloudy

Event

Normal Day

Carnival / Major Event

Other

Estimated % of Trash out of Total Collected: _____ %

Comments: _____

Appendix 3

Calculations for Data Quality Assessment

This appendix documents the calculations used to assess precision, accuracy, and completeness of the data.

Precision

Precision is a measure of the degree to which replicate measurements differ from one another. Precision assessed through calculation of field and laboratory duplicates, and matrix spike duplicates is expressed as the Relative Percent Difference (RPD).

RPD for laboratory and field duplicates is calculated as follows:

$$\text{RPD} = 100 \times \left(\frac{|\text{replicate 1} - \text{replicate 2}|}{(\text{replicate 1} + \text{replicate 2}) \div 2} \right)$$

RPD for matrix spike duplicates is calculated as follows:

$$\text{RPD} = 100 \times \left(\frac{|\text{recovery 1} - \text{recovery 2}|}{(\text{recovery 1} + \text{recovery 2}) \div 2} \right)$$

where *Recovery* is calculated as described for matrix spikes, below.

If assessed with three or more replicate measurements, precision should be expressed as Relative Standard Deviation (RSD). RSD is calculated as:

$$\text{RSD} = 100 \times \left(\frac{\text{standard deviation of replicated measurements}}{\text{average of replicate measurements}} \right)$$

Accuracy

Accuracy is the degree to which a measured value agrees with a true or expected value for a parameter. Accuracy is typically assessed using standard reference materials, laboratory control samples, and matrix spikes. Recovery of laboratory control samples and standard reference materials is calculated as:

$$\% \text{ Recovery} = 100 \times \left(\frac{\text{recovered concentration}}{\text{true spike concentration}} \right)$$

Recovery of matrix spikes is calculated as:

$$\% \text{ Recovery} = 100 \times \left(\frac{\text{total recovered concentration} - \text{sample concentration}}{\text{true spike concentration}} \right)$$

When sample concentrations are less than the method detection limit, a value of "0" (zero) will be used as the sample result concentration for purposes of calculating spike recoveries.

Completeness

Completeness may be defined as the number of valid measurements compared to the total number of measurements collected. Completeness is calculated as:

$$\% \text{ Completeness} = 100 \times \left(\frac{\text{number of valid measurements}}{\text{total number of measurements}} \right)$$

Appendix 4

Chapter 13 QA/QC Data Evaluation from
Caltrans Guidance Manual: Stormwater
Monitoring Protocols, 2nd Edition

SECTION 13

QA/QC DATA EVALUATION

All data reported by the analytical laboratory must be carefully reviewed to determine whether the project's data quality acceptability limits or objectives (DQOs) have been met. This section describes a process for evaluation of all laboratory data, including the results of all QA/QC sample analysis.

Before any results are reported by the laboratory, the deliverable requirements should be clearly communicated to the laboratory, as described in the "Laboratory Data Package Deliverables" discussion in *Section 12*.

The current section discusses QA/QC data evaluation in the following two parts:

KEY TOPICS

- **Initial Data Quality Screening**
- **Data Quality Evaluation**

The initial data quality screening identifies problems with laboratory reporting while they may still be corrected. When the data reports are received, they should be immediately checked for conformity to chain of custody requests to ensure that all requested analyses have been reported. The data are then evaluated for conformity to holding time requirements, conformity to reporting limit requests, analytical precision, analytical accuracy, and possible contamination during sampling and analysis. The data evaluation results in rejection, qualification, and narrative discussion of data points or the data as a whole. Qualification of data, other than rejection, does not necessary exclude use of the data for all applications. It is the decision of the data user, based on specifics of the data application, whether or not to include qualified data points.

➤ **INITIAL DATA QUALITY SCREENING**

The initial screening process identifies and corrects, when possible, inadvertent documentation or process errors introduced by the field crew or the laboratory. The initial data quality control screening should be applied using the following three-step process:

1. *Verification check between sampling and analysis plan (SAP), chain of custody forms, and laboratory data reports:* Chain of custody records should be compared with field logbooks and laboratory data reports to verify the accuracy of all sample identification and to ensure that all samples submitted for analysis have a value reported for each parameter requested. Any deviation from the SAP that has not yet

been documented in the field notes or project records should be recorded and corrected if possible.

Sample representativeness should also be assessed in this step. The minimum acceptable storm capture parameters (number of aliquots and percent storm capture) per amount of rainfall are specified in **Section 10**. Samples not meeting these criteria are generally not analyzed; however, selected analyses can be run at the Caltrans task manager's discretion. If samples not meeting the minimum sample representativeness criteria are analyzed, the resulting data should be rejected ("R") or qualified as estimated ("J"), depending upon whether the analyses were approved by Caltrans. Grab samples should be taken according to the timing protocols specified in the SAP. Deviations from the protocols will result in the rejection of the data for these samples or qualification of the data as estimated. The decision to reject a sample based on sample representativeness should be made prior to the submission of the sample to the laboratory, to avoid unnecessary analytical costs.

2. *Check of laboratory data report completeness:* As discussed in **Section 12**, the end product of the laboratory analysis is a data report that should include a number of QA/QC results along with the environmental results. QA/QC sample results reported by the lab should include both analyses requested by the field crew (field blanks, field duplicates, lab duplicates and MS/MSD analysis), as well as internal laboratory QA/QC results (method blanks and laboratory control samples).

There are often differences among laboratories in terms of style and format of reporting. Therefore, it is prudent to request in advance that the laboratory conform to the style and format approved by Caltrans as shown in **Section 14**. The Caltrans data reviewer should verify that the laboratory data package includes the following items:

- ✓ A narrative which outlines any problems, corrections, anomalies, and conclusions.
- ✓ Sample identification numbers.
- ✓ Sample extraction and analysis dates.
- ✓ Reporting limits for all analyses reported.
- ✓ Results of method blanks.
- ✓ Results of matrix spike and matrix spike duplicate analyses, including calculation of percent recovered and relative percent differences.
- ✓ Results of laboratory control sample analyses.
- ✓ Results of external reference standard analyses.
- ✓ Surrogate spike and blank spike analysis results for organic constituents.

- ✓ A summary of acceptable QA/QC criteria (RPD, spike recovery) used by the laboratory.

Items missing from this list should be requested from the laboratory.

3. *Check for typographical errors and apparent incongruities*: The laboratory reports should be reviewed to identify results that are outside the range of normally observed values. Any type of suspect result or apparent typographical error should be verified with the laboratory. An example of a unique value would be if a dissolved iron concentration has been reported lower than 500 µg/L for every storm event monitored at one location and then a value of 2500 µg/L is reported in a later event. This reported concentration of 2500 µg/L should be verified with the laboratory for correctness.

Besides apparent out-of-range values, the indicators of potential laboratory reporting problems include:

- Significant lack of agreement between analytical results reported for laboratory duplicates or field duplicates.
- Consistent reporting of dissolved metals results higher than total or total recoverable metals.
- Unusual numbers of detected values reported for blank sample analyses.
- Inconsistency in sample identification/labeling.

If the laboratory confirms a problem with the reported concentration, the corrected or recalculated result should be issued in an amended report, or if necessary the sample should be re-analyzed. If laboratory results are changed or other corrections are made by the laboratory, an amended laboratory report should be issued to update the project records.

➤ DATA QUALITY EVALUATION

The data quality evaluation process is structured to provide systematic checks to ensure that the reported data accurately represent the concentrations of constituents actually present in stormwater. Data evaluation can often identify sources of contamination in the sampling and analytical processes, as well as detect deficiencies in the laboratory analyses or errors in data reporting. Data quality evaluation allows monitoring data to be used in the proper context with the appropriate level of confidence.

QA/QC parameters that should be reviewed are classified into the following categories:

- ✓ Reporting limits

- ✓ Holding times
- ✓ Contamination check results (method, field, trip, and equipment blanks)
- ✓ Precision analysis results (laboratory, field, and matrix spike duplicates)
- ✓ Accuracy analysis results (matrix spikes, surrogate spikes, laboratory control samples, and external reference standards)

Each of these QA/QC parameters should be compared to data quality acceptability criteria, inalso known as the project’s data quality objectives (DQOs). The key steps that should be adhered to in the analysis of each of these QA/QC parameters are:

1. Compile a complete set of the QA/QC results for the parameter being analyzed.
2. Compare the laboratory QA/QC results to accepted criteria (DQOs).
3. Compile any out-of-range values and report them to the laboratory for verification.
4. Prepare a report that tabulates the success rate for each QA/QC parameter analyzed.

This process should be applied to each of the QA/QC parameters as discussed below.

Reporting Limits

Stormwater quality monitoring program DQOs should contain a list of acceptable reporting limits that the lab is contractually obligated to adhere to, except in special cases of insufficient sample volume or matrix interference problems. The reporting limits used should ensure a high probability of detection. , Table 12-1 provides recommended reporting limits for selected parameters.

Holding Times

Holding time represents the elapsed time between sample collection time and sample analysis time. Calculate the elapsed time between the sampling time and start of analysis, and compare this to the required holding time. For composite samples that are collected within 24-hours or less, the time of the final sample aliquot is considered the “sample collection time” for determining sample holding time. For analytes with critical holding times (48 hours), composite samples lasting longer than 24-hours require multiple bottle composite samples. Each of these composite samples should represent less than 24 hours of monitored flow, and subsamples from the composites should have been poured off and analyzed by the laboratory for those constituents with critical holding times (*see Section 12*). It is important to review sample holding times to ensure that analyses occurred within the time period that is generally accepted to maintain stable parameter concentrations. Table 12-1 contains the holding times for selected parameters. If holding times are exceeded, inaccurate concentrations or false negative results may be reported.

Samples that exceed their holding time prior to analysis are qualified as “estimated”, or may be rejected depending on the circumstances.

Contamination

Blank samples are used to identify the presence and potential source of sample contamination and are typically one of four types:

1. **Method blanks** are prepared and analyzed by the laboratory to identify laboratory contamination.
2. **Field blanks** are prepared by the field crew during sampling events and submitted to the laboratory to identify contamination occurring during the collection or the transport of environmental samples.
3. **Equipment blanks** are prepared by the field crew or laboratory prior to the monitoring season and used to identify contamination coming from sampling equipment (tubing, pumps, bailers, etc.).
4. **Trip blanks** are prepared by the laboratory, carried in the field, and then submitted to the laboratory to identify contamination in the transport and handling of volatile organics samples.
5. **Filter blanks** are prepared by field crew or lab technicians performing the sample filtration. Blank water is filtered in the same manner and at the same time as other environmental samples. Filter blanks are used to identify contamination from the filter or filtering process.

If no contamination is present, all blanks should be reported as “not detected” or “non-detect” (e.g., constituent concentrations should not be detected above the reporting limit). Blanks reporting detected concentrations (“hits”) should be noted in the written QA/QC data summary prepared by the data reviewer. In the case that the laboratory reports hits on method blanks, a detailed review of raw laboratory data and procedures should be requested from the laboratory to identify any data reporting errors or contamination sources. When other types of blanks are reported above the reporting limit, a similar review should be requested along with a complete review of field procedures and sample handling. Often times it will also be necessary to refer to historical equipment blank results, corresponding method blank results, and field notes to identify contamination sources. This is a corrective and documentative step that should be done as soon as the hits are reported.

If the blank concentration exceeds the laboratory reporting limit, values reported for each associated environmental sample must be evaluated according to USEPA guidelines for data evaluations of organics and metals (USEPA, 1991; USEPA, 1995) as indicated in Table 13-1.

Table 13-1. USEPA Guidelines for Data Evaluation

<i>Step</i>	<i>Environmental Sample</i>	<i>Phthalates and other common contaminants</i>	<i>Other Organics</i>	<i>Metals</i>
1.	Sample > 10X blank concentration	No action	No action	No action
2.	Sample < 10X blank concentration	Report associated environmental results as “non-detect” at the reported environmental concentration.	No action	Results considered an “upper limit” of the true concentration (note contamination in data quality evaluation narrative).
3.	Sample < 5X blank concentration	Report associated environmental results as “non-detect” at the reported environmental concentration.	Report associated environmental results as “non-detect” at the reported environmental concentration.	Report associated environmental results as “non-detect” at the reported environmental concentration.

Specifically, if the concentration in the environmental sample is less than five times the concentration in the associated blank, the environmental sample result is considered, for reporting purposes, “not-detected” *at the environmental sample result concentration* (phthalate and other common contaminant results are considered non-detect if the environmental sample result is less than ten times the blank concentration). The laboratory reports are not altered in any way. The qualifications resulting from the data evaluation are made to the evaluator’s data set for reporting and analysis purposes to account for the apparent contamination problem. For example, if dissolved copper is reported by the laboratory at 4 µg/L and an associated blank concentration for dissolved copper is reported at 1 µg/L, data qualification would be necessary. In the data reporting field of the database (see **Section 14**), the dissolved copper result would be reported as 4 µg/L, the numerical qualifier would be reported as “<”, the reporting limit would be left as reported by the laboratory, and the value qualifier would be reported as “U” (“not detected above the reported environmental concentration”).

When reported environmental concentrations are greater than five times (ten times for phthalates) the reported blank “hit” concentration, the environmental result is reported unqualified at the laboratory-reported concentration. For example, if dissolved copper is reported at 11 µg/L and an associated blank concentration for dissolved copper is reported at 1 µg/L, the dissolved copper result would still be reported as 11 µg/L.

Precision

Duplicate samples provide a measure of the data precision (reproducibility) attributable to sampling and analytical procedures. Precision can be calculated as the relative percent difference (RPD) in the following manner:

$$RPD_i = \frac{2 * |O_i - D_i|}{(O_i + D_i)} * 100\%$$

where:

RPD_i = Relative percent difference for compound i

O_i = Value of compound i in original sample

D_i = Value of compound i in duplicate sample

The resultant RPDs should be compared to the criteria specified in the project's DQOs. The DQO criteria shown in Table 13-2 below are based on the analytical method specifications and laboratory-supplied values. Project-specific DQOs should be developed with consideration to the analytical laboratory, the analytical method specifications, and the project objective. Table 13-2 should be used as a reference point as the least stringent set of DQO criteria for Caltrans monitoring projects.

Laboratory and Field Duplicates

Laboratory duplicates are samples that are split by the laboratory. Each half of the split sample is then analyzed and reported by the laboratory. A pair of field duplicates is two samples taken at the same time, in the same manner into two unique containers. Subsampling duplicates are two unique, ostensibly identical, samples taken from one composite bottle (see **Section 10**). Laboratory duplicate results provide information regarding the variability inherent in the analytical process, and the reproducibility of analytical results. Field duplicate analysis measures both field and laboratory precision, therefore, it is expected that field duplicate results would exhibit greater variability than lab duplicate results. Subsampling duplicates are used as a substitute for field duplicates in some situations and are also an indicator of the variability introduced by the splitting process.

The RPDs resulting from analysis of both laboratory and field duplicates should be reviewed during data evaluation. Deviations from the specified limits, and the effect on reported data, should be noted and commented upon by the data reviewer. Laboratories typically have their own set of maximum allowable RPDs for laboratory duplicates based on their analytical history. In most cases these values are more stringent than those listed in Table 13-2. Note that the laboratory will only apply these maximum allowable RPDs to laboratory duplicates. In most cases field duplicates are submitted "blind" (with pseudonyms) to the laboratory.

Environmental samples associated with laboratory duplicate results greater than the maximum allowable RPD (when the numerical difference is greater than the reporting limit) are qualified as “J” (estimated). When the numerical difference is less than the RL, no qualification is necessary. Field duplicate RPDs are compared against the maximum allowable RPDs used for laboratory duplicates to identify any pattern of problems with reproducibility of results. Any significant pattern of RPD exceedances for field duplicates should be noted in the data report narrative.

Corrective action should be taken to address field or laboratory procedures that are introducing the imprecision of results. The data reviewer can apply “J” (estimated) qualifiers to any data points if there is clear evidence of a field or laboratory bias issue that is not related to contamination. (Qualification based on contamination is assessed with blank samples.)

Laboratories should provide justification for any laboratory duplicate samples with RPDs greater than the maximum allowable value. In some cases, the laboratory will track and document such exceedances, however; in most cases it is the job of the data reviewer to locate these out-of-range RPDs. When asked to justify excessive RPD values for field duplicates, laboratories most often will cite sample splitting problems in the field. Irregularities should be included in the data reviewer’s summary, and the laboratory’s response should be retained to document laboratory performance, and to track potential chronic problems with laboratory analysis and reporting.

Accuracy

Accuracy is defined as the degree of agreement of a measurement to an accepted reference or true value. Accuracy is measured as the percent recovery (%R) of spike compound(s). Percent recovery of spikes is calculated in the following manner:

$$\%R = 100\% * [(C_s - C) / S]$$

where:

- %R = percent recovery
- C_s = spiked sample concentration
- C = sample concentration for spiked matrices
- S = concentration equivalent of spike added

Accuracy (%R) criteria for spike recoveries should be compared with the limits specified in the project DQOs. A list of typical acceptable recoveries is shown in Table 13-2. As in the case of maximum allowable RPDs, laboratories develop acceptable criteria for an allowable range of recovery percentages that may differ from the values listed in Table 13-2.

Percent recoveries should be reviewed during data evaluation, and deviations from the specified limits should be noted in the data reviewer's summary. Justification for out of range recoveries should be provided by the laboratory along with the laboratory reports, or in response to the data reviewer's summary.

Laboratory Matrix Spike and Matrix Spike Duplicate Samples

Evaluation of analytical accuracy and precision in environmental sample matrices is obtained through the analysis of laboratory matrix spike (MS) and matrix spike duplicate (MSD) samples. A matrix spike is an environmental sample that is spiked with a known amount of the constituent being analyzed. A percent recovery can be calculated from the results of the spike analysis. A MSD is a duplicate of this analysis that is performed as a check on matrix recovery precision. MS and MSD results are used together to calculate RPD as with the duplicate samples. When MS/MSD results (%R and RPD) are outside the project specifications, as listed in Table 13-2, the associated environmental samples are qualified as "estimates due to matrix interference". Surrogate standards are added to all environmental and QC samples tested by gas chromatography (GC) or gas chromatography-mass spectroscopy (GC-MS). Surrogates are non-target compounds that are analytically similar to the analytes of interest. The surrogate compounds are spiked into the sample prior to the extraction or analysis. Surrogate recoveries are evaluated with respect to the laboratory acceptance criteria to provide information on the extraction efficiency of every sample.

External Reference Standards

External reference standards (ERS) are artificial certified standards prepared by an external agency and added to a batch of samples. ERS's are not required for every batch of samples, and are often only run quarterly by laboratories. Some laboratories use ERS's in place of laboratory control spikes with every batch of samples. ERS results are assessed the same as laboratory control spikes for qualification purposes (see below). The external reference standards are evaluated in terms of accuracy, expressed as the percent recovery (comparison of the laboratory results with the certified concentrations). The laboratory should report all out-of-range values along with the environmental sample results. ERS values are qualified as "biased high" when the ERS recovery exceeds the acceptable recovery range and "biased low" when the ERS recovery is smaller than the recovery range.

Laboratory Control Samples

LCS analysis is another batch check of recovery of a known standard solution that is used to assess the accuracy of the entire recovery process. LCSs are much like ERS's except that a certified standard is not necessarily used with LCSs, and the sample is prepared internally by the laboratory so the cost associated with preparing a LCS sample is much lower than the cost of ERS preparation. LCSs are reviewed for percent recovery within

control limits provided by the laboratory. LCS out-of-range values are treated in the same manner as ERS out-of-range values. Because LCS and ERS analysis both check the entire recovery process, any irregularity in these results supersedes other accuracy-related qualification. Data are rejected due to low LCS recoveries when the associated environmental result is below the reporting limit.

A flow chart of the data evaluation process, presented on the following pages as Figures 13-1 (lab-initiated QA/QC samples) and 13-2 (field-initiated QA/QC), can be used as a general guideline for data evaluation. Boxes shaded black in Figures 13-1 and 13-2 designate final results of the QA/QC evaluation.

Table 13-2. Typical Control Limits for Precision and Accuracy for Analytical Constituents

Analyte	EPA Method Number or Standard Method	Maximum Allowable RPD	Recovery Upper Limit	Recovery Lower Limit
Conventionals				
BOD	405.1; SM 5210B	20%	80%	120%
COD	410.1; 410.4; SM 5220C; SM 5220D	20%	80%	120%
Hardness	130.2; 130.1; SM 2340B	20%	80%	120%
pH	150.1	20%	NA	NA
TOC/DOC	415.1	15%	85%	115%
TDS	160.1	20%	80%	120%
TSS	160.2	20%	80%	120%
Turbidity	180.1	20%	NA	NA
Nutrients				
NH3-N	350.2; 350.3	20%	80%	120%
NO3-N	300.0	20%	80%	120%
NO2-N	300.0	20%	80%	120%
NO3/NO2-N	353.2	20%	80%	120%
P	365.2	20%	80%	120%
Ortho-P	365.2; 365.3	20%	80%	120%
TKN	351.3	20%	80%	120%
Metals				
Ag	272.2; 200.8	20%	75%	125%
Al	200.9; 200.8	20%	75%	125%
Cd	213.2; 200.8	20%	75%	125%
Cr	218.2; 200.8	20%	75%	125%
Cu	220.2; 200.8	20%	75%	125%
Ni	249.2; 200.8	20%	75%	125%
Pb	239.2; 200.8	20%	75%	125%
Zn	289.2; 200.8	20%	75%	125%
As	206.3; 200.8	20%	75%	125%
Fe	200.9; SM 3500-Fe B	20%	75%	125%
Se	200.9; 270.3; 200.8	20%	75%	125%
Hg	1631	21%	79%	121%
Total Petroleum Hydrocarbons				
TPH (gasoline)	8015b	21%	45%	129%
TPH (diesel)		21%	45%	129%
TPH (motor oil)		21%	45%	129%
Oil & Grease	1664	18%	79%	114%
Pesticides and Herbicides				
Glyphosate	547	30%	70%	130%
OP Pesticides (esp. diazinon and chlorpyrifos)	8141; ELISA	25%	see method for constituent specific	
OC Pesticides	8081	25%		
Chlorinated Herbicides	8150; 8151	25%		
Carbamate Pesticides	8321	25%		
Miscellaneous Organic Constituents				
Base/Neutrals and Acids	625; 8270	30% to 50% (analyte dependent)		see method for constituent specific
PAHs	8310			
Purgeables	624; 8260	20%		
Purgeable Halocarbons	601	30%		see method, Table 2
Purgeable Aromatics	602	20%		see method for constituent specific
Miscellaneous Constituents				
Cyanide	335.2	20%	75	125
Bacteriological				
Fecal Coliform	SM 9221E	-	-	-
Total Coliform	SM 9221B	-	-	-

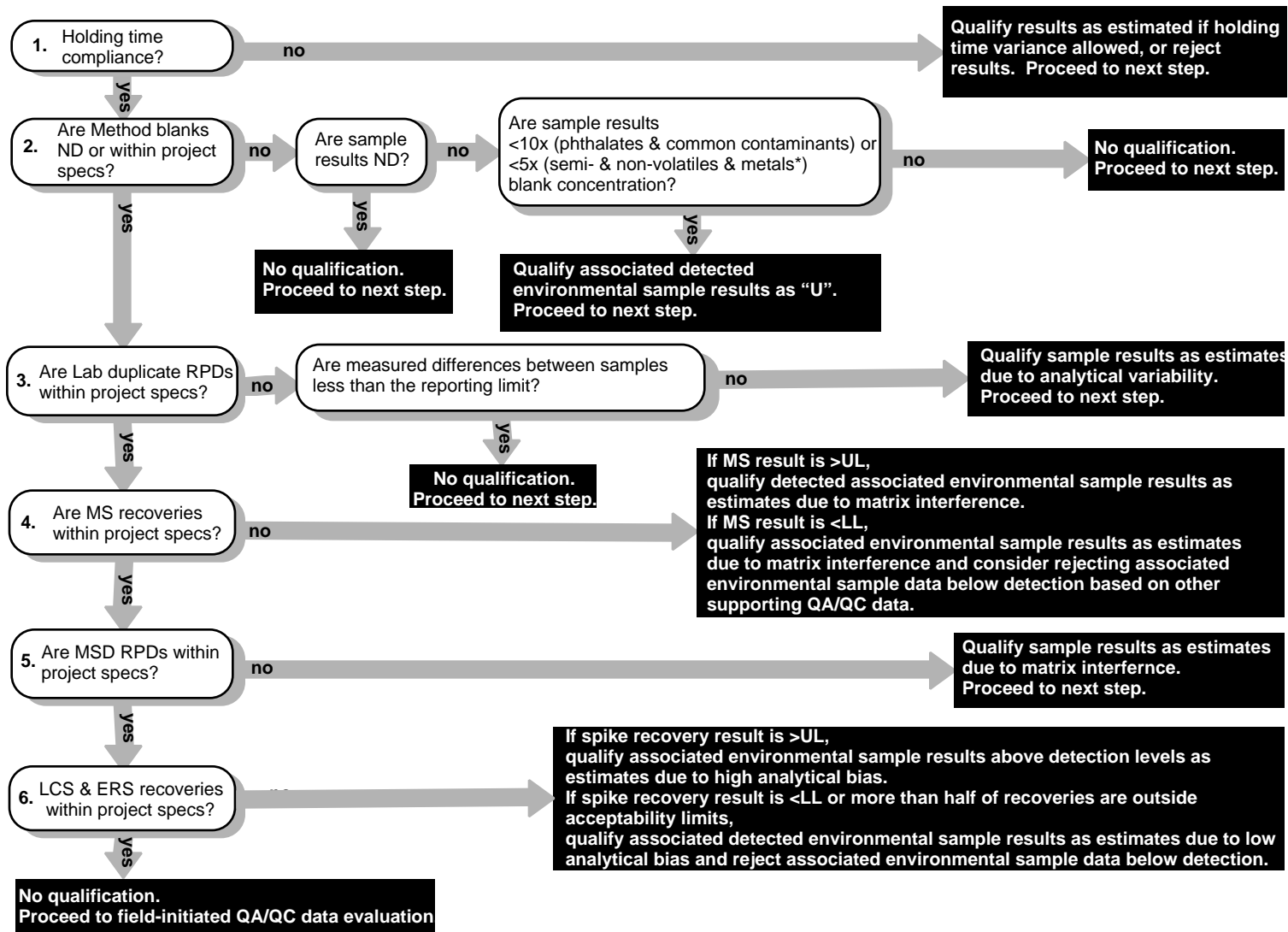

*Environmental results between 5x and 10x the blank concentration are qualified as “an upper limit on the true concentration” and the data user should be cautioned.

Figure 13-1. Technical Data Evaluation for Lab-Initiated QA/QC Samples

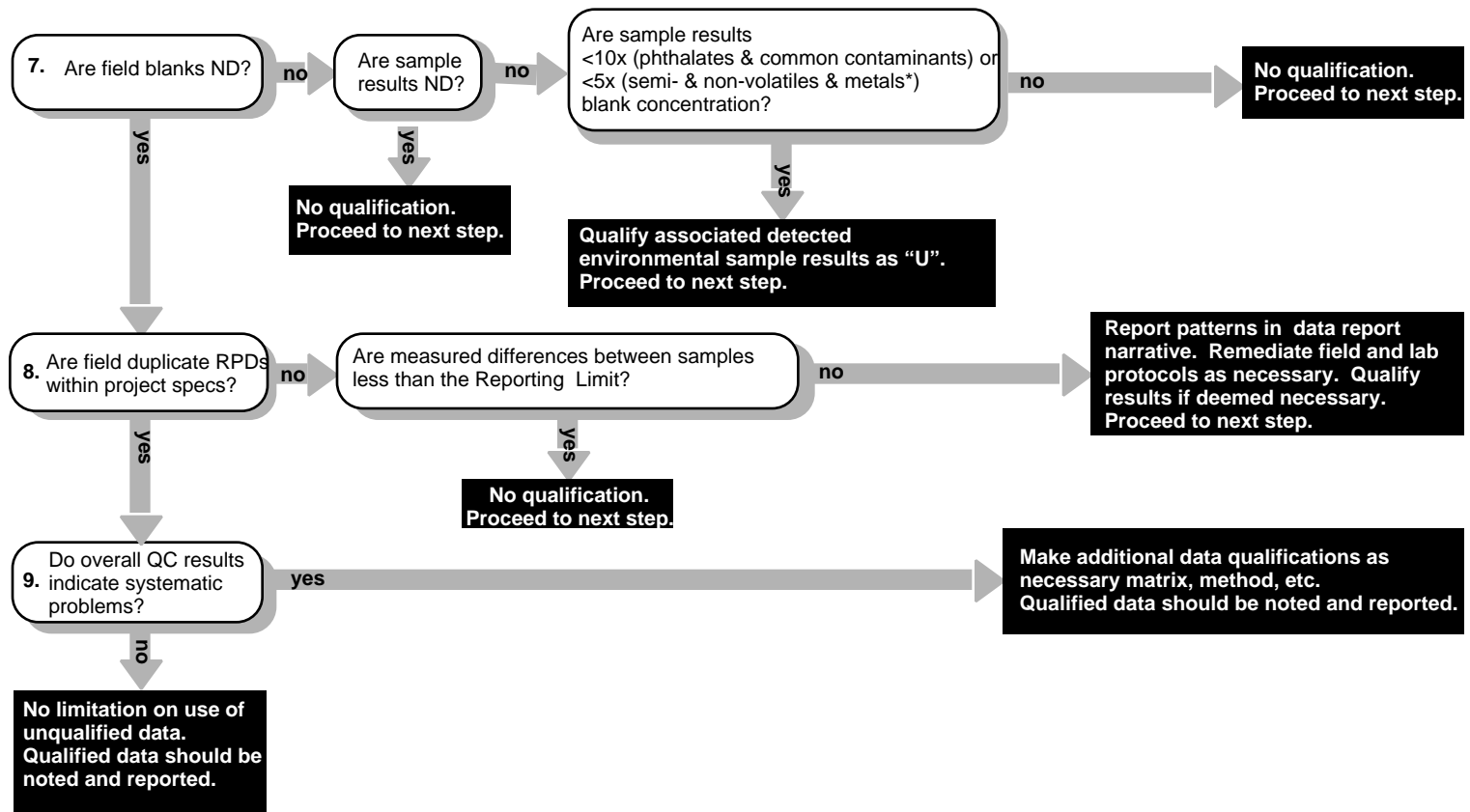

*Environmental results between 5x and 10x the blank concentration are qualified as "an upper limit on the true concentration" and the data user should be cautioned.

Figure 13-2. Technical Data Evaluation for Field-Initiated QA/QC Samples