



EDMUND G. BROWN JR.
GOVERNOR

MATTHEW ROMBOUF
SECRETARY FOR
ENVIRONMENTAL PROTECTION

California Regional Water Quality Control Board, San Diego Region

ORDER NO. R9-2012-0004
NPDES NO. CA0108031

WASTE DISCHARGE REQUIREMENTS
FOR THE FALLBROOK PUBLIC UTILITY DISTRICT
WASTEWATER TREATMENT PLANT NO. 1
DISCHARGE TO THE PACIFIC OCEAN VIA THE OCEANSIDE OCEAN OUTFALL

The following Discharger is subject to waste discharge requirements as set forth in this Order:

Table 1. Discharger and Facility Information

Discharger	Fallbrook Public Utility District
Name of Facility	Fallbrook Public Utility District Treatment Plant No. 1
Facility Address	1425 South Alturas Road Fallbrook, CA 92028
The U.S. Environmental Protection Agency (USEPA) and the California Regional Water Quality Control Board, San Diego Region have classified this discharge as a major discharge.	

Discharges by the Fallbrook Public Utility District from the Facility listed in Table 1 at the discharge point identified in Table 2 are subject to waste discharge requirements as set forth in this Order:

Table 2. Discharge Location

Discharge Point No.	Effluent Description	Discharge Point Latitude	Discharge Point Longitude	Receiving Water
001	POTW effluent	33° 09' 46" N	117° 23' 29" W	Pacific Ocean

Table 3. Administrative Information

This Order was adopted by the California Regional Water Quality Control Board, San Diego Region on:	August 8, 2012
This Order shall become effective on:	September 28, 2012
This Order shall expire on:	September 27, 2017
The Discharger shall file a Report of Waste Discharge in accordance with Title 23, California Code of Regulations, not later than 180 days in advance of the Order expiration date as application for issuance of new waste discharge requirements.	

I, David W. Gibson, Executive Officer, do hereby certify that this Order with all attachments is a full, true, and correct copy of an Order adopted by the California Regional Water Quality Control Board, San Diego Region, on August 8, 2012.

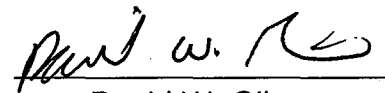

David W. Gibson
Executive Officer

Table of Contents

I. Facility Information - 4 -

II. Findings - 4 -

III. Discharge Prohibitions - 9 -

IV. Effluent Limitations and Discharge Specifications - 9 -

 A. Effluent Limitations and Performance Goals – Discharge Point No. 001 - 9 -

 B. Land Discharge Specifications – Not Applicable - 14 -

 C. Reclamation Specifications - 14 -

V. Receiving Water Limitations - 14 -

 A. Surface Water Limitations - 14 -

 B. Groundwater Limitations – Not Applicable - 16 -

VI. Provisions - 16 -

 A. Standard Provisions - 16 -

 B. Monitoring and Reporting Program (MRP) Requirements - 17 -

 C. Special Provisions - 17 -

 1. Reopener Provisions - 17 -

 2. Special Studies, Technical Reports and Additional Monitoring Requirements .. - 19 -

 3. Best Management Practices and Pollution Prevention – Not Applicable - 21 -

 4. Construction, Operation and Maintenance Specifications – Not Applicable - 21 -

 5. Special Provisions for Wastewater Facilities (POTWs Only) - 21 -

 6. Other Special Provisions – Not Applicable - 23 -

 7. Compliance Schedules - 23 -

VII. Compliance Determination - 24 -

List of Tables

Table 1. Discharger and Facility Information - 1 -

Table 2. Discharge Location - 1 -

Table 3. Administrative Information - 2 -

Table 4. Facility Information - 4 -

Table 5. Basin Plan Beneficial Uses of the Pacific Ocean - 6 -

Table 6. Ocean Plan Beneficial Uses of the Pacific Ocean - 6 -

Table 7. Effluent Limitations at M-001 (Secondary Effluent from Wastewater Treatment Plant No. 1) - 9 -

Table 8. Effluent Limitations at M-001 or M-002 - 10 -

Table 9. Performance Goals - 11 -

List of Attachments

Attachment A – Definitions A-1

Attachment B – Map B-1

Attachment C – Flow Schematic C-1

Attachment D – Standard Provisions D-1

Attachment E – Monitoring and Reporting Program E-1

Attachment F – Fact Sheet F-1

Attachment G – Discharge Prohibitions contained in the Ocean Plan and Basin Plan G-1

I. FACILITY INFORMATION

The following Discharger is subject to waste discharge requirements as set forth in this Order:

Table 4. Facility Information

Discharger	Fallbrook Public Utility District
Name of Facility	Fallbrook Public Utility District Treatment Plant No. 1
Facility Address	1425 South Alturas Road Fallbrook, CA 92028
Facility Contact, Title, and Phone	Jack Bebee, Engineering and Planning Manager, (760) 728-1125
Mailing Address	990 East Mission Road P.O. Box 2290, Fallbrook, CA 92088
Type of Facility	Publicly Owned Treatment Works (POTW)
Facility Permitted Discharge Flow Rate	2.7 million gallons per day (MGD)

II. FINDINGS

The California Regional Water Quality Control Board, San Diego Region (hereinafter San Diego Water Board), finds:

A. Background. The Fallbrook Public Utility District (hereinafter Discharger or FPUD) is currently discharging pursuant to Order No. R9-2006-002 and National Pollutant Discharge Elimination System (NPDES) Permit No. CA0108031. FPUD submitted a Report of Waste Discharge (ROWD), dated September 30, 2010, and applied for a NPDES permit renewal to discharge up to 2.7 MGD of treated wastewater to the Oceanside Ocean Outfall (Oceanside OO) from Treatment Plant No. 1, hereinafter Facility. The application was deemed complete on October 30, 2010.

B. Facility Description. FPUD owns and operates Treatment Plant No. 1, the FPUD land outfall pipeline, and the FPUD sanitary collection system, hereinafter FPUD Facilities. FPUD’s Treatment Plant No. 1 is a publicly owned treatment works (POTW) as defined in section 403.3, title 40 of the Code of Federal Regulations (40 CFR 403.3). FPUD provides municipal wastewater treatment services to a population of approximately 25,000 within the boundaries of the FPUD, treating primarily residential and commercial wastewater. There are no significant industrial users within the FPUD service area

Wastewater treatment processes at Treatment Plant No.1 include preliminary treatment by mechanical bar screening, aerated grit removal, primary sedimentation, aeration and secondary clarification (activated sludge treatment process), and chlorination. Sludge from the secondary treatment facilities is thickened, aerobically digested, and dewatered via centrifuge. Dewatered sludge is fed to a thermal dryer system to produce Class A EQ sewage sludge and disposed of via land application. If the dryer system is off-line, sewage sludge is dewatered via drying beds and hauled to a land application site in Yuma, Arizona by a contractor. Grit and screenings collected from preliminary treatment processes are collected and disposed of at a landfill in San Diego County.

Recycled water distributed from the Facility is regulated under a separate order, Order No. 91-39, which is not incorporated by reference into this permit. Treated wastewater from the Facility that is not distributed as recycled water, hereinafter referred to as effluent, is discharged to the

FPUD-owned land outfall pipeline. This pipeline conveys effluent to the Oceanside OO at the site of the City of Oceanside's La Salina Wastewater Treatment Plant. FPUD has a contractual agreement with the City of Oceanside to discharge up to 2.4 MGD on an annual average basis through the Oceanside OO. The Oceanside OO is owned and operated by the City of Oceanside.

The City of Oceanside is regulated under Order No. R9-2011-0016 (NPDES Permit No. CA0107433) and has a total flow limitation of 22.9 MGD. An additional 6.155 MGD of capacity is allocated to FPUD, US Marine Corps Base Camp Pendleton, and Genetech, Inc. Attachment B of this Order provides maps of the area around the Facility, land outfall pipelines, and the Oceanside OO. Attachment C of this Order provides flow schematics of the Facility.

- C. Legal Authorities.** This Order is issued pursuant to section 402 of the federal Clean Water Act (CWA) and implementing regulations adopted by the United States Environmental Protection Agency (USEPA) and chapter 5.5, division 7 of the California Water Code (CWC) (commencing with section 13370). It shall serve as a NPDES permit for point source discharges from this Facility to surface waters. This Order also serves as Waste Discharge Requirements (WDRs) pursuant to article 4, chapter 4, division 7 of the CWC (commencing with section 13260).
- D. Background and Rationale for Requirements.** The San Diego Water Board developed the requirements in this Order based on information submitted as part of the application, through monitoring and reporting programs, and other available information. The Fact Sheet (Attachment F), which contains background information and rationale for Order requirements, is hereby incorporated into this Order and constitutes part of the Findings for this Order. Attachments A through E and G are also incorporated into this Order.
- E. California Environmental Quality Act (CEQA).** Under CWC section 13389, this action to adopt a NPDES permit is exempt from the provisions of CEQA, Public Resources Code sections 21100-21177.
- F. Technology-Based Effluent Limitations.** Section 301(b) of the CWA and implementing USEPA permit regulations at 40 CFR 122.44, require that permits include conditions meeting applicable technology-based requirements at a minimum, and any more stringent effluent limitations necessary to meet applicable water quality standards. 40 CFR Part 133 establishes the minimum weekly and monthly average level of effluent quality attainable by secondary treatment for carbonaceous biochemical oxygen demand (CBOD₅), total suspended solids (TSS), and the instantaneous minimum and maximums for pH. The discharge authorized by this Order must meet minimum federal technology-based requirements based on Secondary Treatment Standards at 40 CFR Part 133. TBELs contained in Table A of the 2009 *Water Quality Control Plan for Ocean Waters of California, California Ocean Plan* (hereinafter Ocean Plan), which include grease and oil, TSS, settleable solids, turbidity, and pH, are also applicable to discharges from the Facility. A detailed discussion of the technology-based effluent limitations (TBELs) development is included in the Fact Sheet (Attachment F).
- G. Water Quality-Based Effluent Limitations.** Section 301(b) of the CWA and 40 CFR 122.44(d) require that permits include limitations more stringent than applicable federal technology-based requirements where necessary to achieve applicable water quality standards.

40 CFR 122.44(d)(1)(i) mandates that permits include effluent limitations for all pollutants that are or may be discharged at levels that have the reasonable potential to cause or contribute to an exceedance of a water quality standard, including numeric and narrative objectives within a standard. Where reasonable potential has been established for a pollutant, but there is no

numeric criterion or objective for the pollutant, water quality-based effluent limitations (WQBELs) must be established using: (1) USEPA criteria guidance under CWA section 304(a), supplemented where necessary by other relevant information; (2) an indicator parameter for the pollutant of concern; or (3) a calculated numeric water quality criterion, such as a proposed state criterion or policy interpreting the state’s narrative criterion, supplemented with other relevant information, as provided in 40 CFR 122.44(d)(1)(vi).

H. Water Quality Control Plans. The San Diego Water Board adopted a *Water Quality Control Plan for the San Diego Region* (hereinafter Basin Plan) on September 8, 1994 that designates beneficial uses, establishes water quality objectives, and contains implementation programs and policies to achieve those objectives for the Pacific Ocean and other receiving waters addressed through the plan. Subsequent revisions to the Basin Plan have also been adopted by the San Diego Water Board and approved by the State Water Resources Control Board (State Water Board). Beneficial uses applicable to the Pacific Ocean specified in the Basin Plan are as follows:

Table 5. Basin Plan Beneficial Uses of the Pacific Ocean

Discharge Point No.	Receiving Water Name	Beneficial Use(s)
001	Pacific Ocean	Industrial service supply; navigation; contact water recreation; non-contact water recreation; commercial and sport fishing; preservation of biological habitats of special significance; wildlife habitat; rare, threatened, or endangered species; marine habitat; aquaculture; migration of aquatic organisms; spawning, reproduction, and/or early development; and shellfish harvesting.

Requirements of this Order implement the Basin Plan.

I. California Ocean Plan. The State Water Board adopted the Ocean Plan in 1972 and amended it in 1978, 1983, 1988, 1990, 1997, 2000, 2005, and 2009. The State Water Board adopted the latest amendment on September 15, 2009 and it became effective on March 10, 2010. The Ocean Plan is applicable, in its entirety, to point source discharges to the ocean. The Ocean Plan identifies beneficial uses of ocean waters of the State to be protected as summarized below:

Table 6. Ocean Plan Beneficial Uses of the Pacific Ocean

Discharge Point No.	Receiving Water Name	Beneficial Use
001	Pacific Ocean	Industrial water supply; water contact and non-contact recreation, including aesthetic enjoyment; navigation; commercial and sport fishing; mariculture; preservation and enhancement of designated Areas of Special Biological Significance (ASBS); rare and endangered species; marine habitat; fish migration; fish spawning and shellfish harvesting.

In order to protect the beneficial uses, the Ocean Plan establishes water quality objectives and a program of implementation. Requirements of this Order implement the Ocean Plan.

J. Alaska Rule. On March 30, 2000, USEPA revised its regulation that specifies when new and revised state and tribal water quality standards (WQS) become effective for CWA purposes. (40 CFR 131.21; 65 Fed. Reg. 24641 (April 27, 2000).) Under the revised regulation (also known as the Alaska rule), new and revised standards submitted to USEPA after May 30, 2000, must be approved by USEPA before being used for CWA purposes. The final rule also provides that standards already in effect and submitted to USEPA by May 30, 2000 may be used for CWA purposes, whether or not approved by USEPA.

K. Stringency of Requirements for Individual Pollutants. This Order contains both TBELs and WQBELs for individual pollutants. The TBELs consist of restrictions on CBOD₅, TSS, pH, oil and grease, settleable solids, and turbidity. Restrictions on these pollutants are discussed in section IV.B of the Fact Sheet (Attachment F of this Order). This Order's technology-based pollutant restrictions implement the minimum, applicable federal technology-based requirements. These limitations are not more stringent than required by the CWA.

WQBELs have been scientifically derived to implement water quality objectives that protect beneficial uses. Both the beneficial uses and the water quality objectives have been approved pursuant to federal law and are the applicable federal water quality standards. The scientific procedures for calculating the individual WQBELs are based on the Ocean Plan, which was approved by USEPA on October 8, 2010. All beneficial uses and water quality objectives contained in the Basin Plan were approved under state law and submitted to and approved by USEPA prior to May 30, 2000. Any water quality objectives and beneficial uses submitted to USEPA prior to May 30, 2000, but not approved by USEPA before that date, are nonetheless "applicable water quality standards for purposes of the CWA" pursuant to 40 CFR 131.21(c)(1). This Order's restrictions on individual pollutants are no more stringent than required to implement the requirements of the CWA.

L. Antidegradation Policy. 40 CFR 131.12 requires that the State water quality standards include an antidegradation policy consistent with the federal policy. The State Water Board established California's antidegradation policy in State Water Board Resolution No. 68-16. Resolution No. 68-16 incorporates the federal antidegradation policy where the federal policy applies under federal law. Resolution No. 68-16 requires that existing quality of waters be maintained unless degradation is justified based on specific findings. The San Diego Water Board's Basin Plan implements, and incorporates by reference, both the State and federal antidegradation policies (San Diego Basin Plan Chapter 3, page 3-2). As discussed in detail in the Fact Sheet (Attachment F of this Order), the permitted discharge is consistent with the antidegradation provision of 40 CFR 131.12 and State Water Board Resolution No. 68-16.

M. Anti-Backsliding Requirements. Sections 402(o)(2) and 303(d)(4) of the CWA and federal regulations at 40 CFR 122.44(l) prohibit backsliding in NPDES permits. These anti-backsliding provisions require effluent limitations in a reissued permit to be as stringent as those in the previous permit, with some exceptions where limitations may be relaxed. Some effluent limitations in this Order are less stringent than those in the previous Order. As discussed in detail in the Fact Sheet (Attachment F of this Order), this relaxation of effluent limitations is consistent with the anti-backsliding requirements of the CWA and federal regulations.

N. Endangered Species Act. This Order does not authorize any act that results in the taking of a threatened or endangered species or any act that is now prohibited, or becomes prohibited in the future, under either the California Endangered Species Act (Fish and Game Code sections 2050 to 2097) or the Federal Endangered Species Act (16 USCA sections 1531 to 1544). This Order requires compliance with effluent limits, receiving water limits, and other requirements to

protect the beneficial uses of waters of the State. FPUD is responsible for meeting all requirements of the applicable Endangered Species Act.

- O. Monitoring and Reporting.** 40 CFR 122.48 requires that all NPDES permits specify requirements for recording and reporting monitoring results. CWC sections 13267 and 13383 authorize the San Diego Water Board to require technical and monitoring reports. The Monitoring and Reporting Program (MRP) establishes monitoring and reporting requirements to implement federal and State requirements. This MRP is provided in Attachment E of this Order.
- P. Standard and Special Provisions.** Standard Provisions, which apply to all NPDES permits in accordance with 40 CFR 122.41, and additional conditions applicable to specified categories of permits in accordance with 40 CFR 122.42, are provided in Attachment D of this Order. The San Diego Water Board has also included in this Order special provisions applicable to FPUD. A rationale for the special provisions contained in this Order is provided in the Fact Sheet (Attachment F of this Order).
- Q. Provisions and Requirements Implementing State Law.** Some of the provisions/requirements in subsections VI.C of this Order are included to implement State law only. These provisions/requirements are not required or authorized under the federal CWA; consequently, violations of these provisions/requirements are not subject to the enforcement remedies that are available for NPDES violations. As described in the fact sheet, the requirements of this Order take into consideration the beneficial uses to be protected, the water quality objectives reasonably required for that purpose, other waste discharges, the need to prevent nuisance, and the provisions of CWC section 13241.
- R. Executive Officer Delegation of Authority.** The San Diego Water Board by prior resolution has delegated all matters that may legally be delegated to its Executive Officer to act on its behalf pursuant to CWC section 13223. Therefore, the Executive Officer is authorized to act on the San Diego Water Board's behalf on any matter within this Order unless such delegation is unlawful under CWC section 13223 or this Order explicitly states otherwise
- S. Notification of Interested Parties.** The San Diego Water Board has notified FPUD and interested agencies and persons of its intent to prescribe Waste Discharge Requirements for the discharge and has provided them with an opportunity to submit their written comments and recommendations. Details of notification are provided in the Fact Sheet (Attachment F of this Order).
- T. Consideration of Public Comment.** The San Diego Water Board, in a public meeting, heard and considered all comments pertaining to the discharge. Details of the Public Hearing are provided in the Fact Sheet (Attachment F of this Order).

THEREFORE, IT IS HEREBY ORDERED, that Order No. R9-2006-002 is rescinded upon the effective date of this Order except for enforcement purposes, and, in order to meet the provisions contained in division 7 of the CWC (commencing with section 13000) and regulations adopted thereunder, and the provisions of the federal CWA and regulations and guidelines adopted thereunder, FPUD shall comply with the requirements in this Order.

III. DISCHARGE PROHIBITIONS

- A.** The discharge of waste from the Facility not treated by a secondary treatment process and not in compliance with the effluent limitations specified in section IV.A of this Order, and/or to a location other than Discharge Point No. 001, unless specifically regulated by this Order or separate waste discharge requirements, is prohibited.
- B.** The bypassing of untreated wastes is prohibited, except as allowed by Federal Standard Provisions I.G or I.H of this Order. (Attachment D).
- C.** The discharge of wastes from the Facility during dry-weather months (May to October) in excess of a monthly average effluent flow of 2.7 MGD, and during wet-weather months (November to April) in excess of a monthly average effluent flow of 3.6 MGD is prohibited.
- D.** The Discharger must comply with Ocean Plan Discharge Prohibitions, summarized in Attachment G, as a condition of this Order.
- E.** The Discharger must comply with Discharge Prohibitions contained in Chapter 4 of the Basin Plan, summarized in Attachment G, as a condition of this Order

IV. EFFLUENT LIMITATIONS AND DISCHARGE SPECIFICATIONS

A. Effluent Limitations and Performance Goals – Discharge Point No. 001

1. Final Effluent Limitations

- a.** FPU D shall maintain compliance with the following effluent limitations at Monitoring Locations M-001, as described in the attached MRP (Attachment E of this Order).

Table 7. Effluent Limitations at M-001 (Secondary Effluent from Wastewater Treatment Plant No. 1)

Parameter	Units	Effluent Limitations					
		Average Monthly	Average Weekly	Maximum Daily	Instantaneous Minimum	Instantaneous Maximum	6-Month Median
Carbonaceous Biochemical Oxygen Demand (5-day @ 20°C) (CBOD ₅) ¹	mg/L	25	40	--	--	--	--
	lbs/day	560	900	--	--	--	--
TSS ¹	mg/L	30	45	--	--	--	--
	lbs/day	680	1,000	--	--	--	--
Oil and Grease	mg/L	25	40	--	--	75	--
	lbs/day	560	900	--	--	1,700	--
Settleable Solids	ml/L	1.0	1.5	--	--	3.0	--
Turbidity	NTU	75	100	--	--	225	--
pH	standard units	--	--	--	6.0	9.0	--

¹ The average monthly percent removal of CBOD₅ and TSS shall not be less than 85 percent.

- b. FPUD shall maintain compliance with the following effluent limitations at Discharge Point No. 001, with compliance measured at Monitoring Locations M-001 or M-002 as described in the attached MRP (Attachment E of this Order):

Table 8. Effluent Limitations at M-001 or M-002

Parameter	Unit	Effluent Limitations ¹			
		6-Month Median	Maximum Daily	Instantaneous Maximum	Average Monthly
OBJECTIVES FOR PROTECTION OF MARINE AQUATIC LIFE					
Total Residual Chlorine ²	µg/L	180	700	5,300	
	lbs/day	4.0	16	120	
OBJECTIVES FOR PROTECTION OF HUMAN HEALTH – CARCINOGENS					
TCDD ³	µg/L	--	--	--	3.4E-07
	lbs/day	--	--	--	7.7E-09

¹ Scientific “E” notation is used to express effluent limitations. In scientific “E” notation, the number following the “E” indicates that position of the decimal point in the value. Negative numbers after the “E” indicate that the value is less than 1, and positive numbers after the “E” indicate that the value is greater than 1. In this notation a value of 6.1E-02 represents 6.1 x 10⁻² or 0.061, 6.1E+02 represents 6.1 x 10² or 610, and 6.1E+00 represents 6.1 x 10⁰ or 6.1.

² The water quality objectives for total chlorine residual applicable to intermittent discharges not exceeding two hours shall be determined through use of the following equation:

$$\log y = 0.43(\log x) + 1.8$$

where,

y = the water quality objective (in µg/L) to apply when chlorine is being discharged;

x = the duration of uninterrupted chlorine discharge in minutes.

Actual effluent limitations for total chlorine, when discharging intermittently, shall then be determined according to Implementation Procedures for Table B from the Ocean Plan and using a minimum probable dilution factor of 87 and a flow rate of 2.7 MGD.

³ TCDD equivalents represent the sum of concentrations of chlorinated dibenzodioxins (2,3,7,8-CDDs) and chlorinated dibenzofurans (2,3,7,8-CDFs) multiplied by their respective toxicity factors.

2. Performance Goals

- a. Constituents that do not have reasonable potential to cause or contribute to an exceedance of water quality objectives, or for which reasonable potential to cause or contribute to an exceedance of water quality objectives cannot be determined, are referred to as performance goal constituents and are assigned the performance goals listed in the following table. Performance goal constituents shall be monitored at M-001 or M-002, but the results will be used for informational purposes only, not compliance determination, because the listed performance goals are not enforceable as effluent limitations.

Table 9. Performance Goals

Parameter	Unit	Performance Goals ¹			
		6-Month Median	Maximum Daily	Instantaneous Maximum	30-Day Average
OBJECTIVES FOR PROTECTION OF MARINE AQUATIC LIFE					
Arsenic, Total Recoverable	µg/L	4.4E+02	2.6E+03	6.8E+03	--
Cadmium, Total Recoverable	µg/L	8.8E+01	3.5E+02	8.8E+02	--
Chromium VI, Total Recoverable ²	µg/L	1.8E+02	7.0E+02	1.8E+03	--
Copper, Total Recoverable	µg/L	9.0E+01	8.8E+02	2.5E+03	--
Lead, Total Recoverable	µg/L	1.8E+02	7.0E+02	1.8E+03	--
Mercury, Total Recoverable	µg/L	3.09E+00	1.4E+01	3.5E+01	--
Nickel, Total Recoverable	µg/L	4.4E+02	1.8E+03	4.4E+03	--
Selenium, Total Recoverable	µg/L	1.3E+03	5.3E+03	1.3E+04	--
Silver, Total Recoverable	µg/L	4.8E+01	2.3E+02	6.0E+02	--
Zinc, Total Recoverable	µg/L	1.1E+03	6.3E+03	1.7E+04	--
Cyanide, Total Recoverable ³	µg/L	8.8E+01	3.5E+02	8.8E+02	
Ammonia (expressed as nitrogen)	µg/L	5.3E+04	2.1E+05	5.3E+05	--
Acute Toxicity	TUa	--	2.9E+00	--	
Chronic Toxicity ⁴	TUc	--	8.8E+01	--	--
Phenolic Compounds (non-chlorinated) ⁵	µg/L	2.6E+03	1.1E+04	2.6E+04	--
Chlorinated Phenolics ⁶	µg/L	8.8E+01	3.5E+02	8.8E+02	--
Endosulfan ⁷	µg/L	7.9E-01	1.6E+00	2.4E+00	--
Endrin	µg/L	1.8E-01	3.5E-01	5.3E-01	--
HCH ⁸	µg/L	3.5E-01	7.0E-01	1.1E+00	--
Radioactivity	pCi/L	Not to exceed limits specified in Title 17, Division 1, Chapter 5, Subchapter 4, Group 3, Article 3, Section 30253 of the California Code of Regulations, Reference to Section 30253 is prospective, including future changes to any incorporated provisions of federal law, as the changes take effect.			

OBJECTIVES FOR PROTECTION OF HUMAN HEALTH – NONCARCINOGENS					
Acrolein	µg/L	--	--	--	1.9E+04
Antimony	µg/L	--	--	--	1.1E+05
Bis(2-chloroethoxy) Methane	µg/L	--	--	--	3.9E+02
Bis(2-chloroisopropyl) Ether	µg/L	--	--	--	1.1E+05
Chlorobenzene	µg/L	--	--	--	5.0E+04
Chromium (III), Total Recoverable	µg/L	--	--	--	1.7E+07
Di-n-butyl Phthalate	µg/L	--	--	--	3.1E+05
Dichlorobenzenes ⁹	µg/L	--	--	--	4.5E+05
Diethyl Phthalate	µg/L	--	--	--	2.9E+06
Dimethyl Phthalate	µg/L	--	--	--	7.2E+07
4,6-dinitro-2-methylphenol	µg/L	--	--	--	1.9E+04
2,4-dinitrophenol	µg/L	--	--	--	3.5E+02
Ethylbenzene	µg/L	--	--	--	3.6E+05
Fluoranthene	µg/L	--	--	--	1.3E+03
Hexachlorocyclopentadiene	µg/L	--	--	--	5.1E+03
Nitrobenzene	µg/L	--	--	--	4.3E+02
Thallium, Total Recoverable	µg/L	--	--	--	1.8E+02
Toluene	µg/L	--	--	--	7.5E+06
Tributyltin	µg/L	--	--	--	1.2E-01
1,1,1-trichloroethane	µg/L	--	--	--	4.8E+07
OBJECTIVES FOR PROTECTION OF HUMAN HEALTH – CARCINOGENS					
Acrylonitrile	µg/L	--	--	--	8.8E+00
Aldrin	µg/L	--	--	--	1.9E-03
Benzene	µg/L	--	--	--	5.2E+02
Benzidine	µg/L	--	--	--	6.1E-03
Beryllium	µg/L	--	--	--	2.9E+00
Bis(2-chloroethyl) Ether	µg/L	--	--	--	4.0E+00
Bis(2-ethylhexyl) Phthalate	µg/L	--	--	--	3.1E+02
Carbon Tetrachloride	µg/L	--	--	--	7.9E+01
Chlorodane	µg/L	--	--	--	2.0E-03
Chlorodibromomethane	µg/L	--	--	--	7.6E+02
Chloroform	µg/L	--	--	--	1.1E+04
DDT ¹⁰	µg/L	--	--	--	1.5E-02
1,4-dichlorobenzene	µg/L	--	--	--	1.6E+03
3,3'-dichlorobenzidine	µg/L	--	--	--	7.1E-01
1,2-dichloroethane	µg/L	--	--	--	2.5E+03
1,1-dichloroethylene	µg/L	--	--	--	7.9E+01
Dichlorobromomethane	µg/L	--	--	--	5.5E+02
Dichloromethane	µg/L	--	--	--	4.0E+04
1,3-dichloropropene	µg/L	--	--	--	7.8E+02
Dieldrin	µg/L	--	--	--	3.5E-03
2,4-dinitrotoluene	µg/L	--	--	--	2.3E+02
1,2-diphenylhydrazine	µg/L	--	--	--	1.4E+01
Halomethanes ¹¹	µg/L	--	--	--	1.1E+04

Heptachlor	µg/L	--	--	--	4.4E-03
Heptachlor Epoxide	µg/L	--	--	--	1.8E-03
Hexachlorobenzene	µg/L	--	--	--	1.8E-02
Hexachlorobutadiene	µg/L	--	--	--	1.2E+03
Hexachloroethane	µg/L	--	--	--	2.2E+02
Isophorone	µg/L	--	--	--	6.4E+04
N-nitrosodimethylamine	µg/L	--	--	--	6.4E+02
N-nitrosodi-N-propylamine	µg/L	--	--	--	3.3E+01
N-nitrosodiphenylamine	µg/L	--	--	--	2.2E+02
PAHs ¹²	µg/L	--	--	--	7.7E-01
PCBs ¹³	µg/L	--	--	--	1.7E-03
1,1,2-tetrachloroethane	µg/L	--	--	--	2.0E+02
Tetrachloroethylene	µg/L	--	--	--	1.8E+02
Toxaphene	µg/L	--	--	--	1.8E-02
Trichloroethylene	µg/L	--	--	--	2.4E+03
1,1,2-trichloroethane	µg/L	--	--	--	8.3E+02
2,4,6-trichlorophenol	µg/L	--	--	--	2.6E+01
Vinyl Chloride	µg/L	--	--	--	3.2E+03

- 1 Scientific "E" notation is used to express certain values. In scientific "E" notation, the number following the "E" indicates that position of the decimal point in the value. Negative numbers after the "E" indicate that the value is less than 1, and positive numbers after the "E" indicate that the value is greater than 1. In this notation a value of 6.1E-02 represents 6.1 x 10⁻² or 0.061, 6.1E+02 represents 6.1 x 10² or 610, and 6.1E+00 represents 6.1 x 10⁰ or 6.1.
- 2 Dischargers may, at their option, apply this performance goal as a total chromium performance goal.
- 3 If FPUD can demonstrate to the satisfaction of the San Diego Water Board (subject to USEPA approval) that an analytical method is available to reliably distinguish between strongly and weakly complexed cyanide, performance goals may be evaluated with the combined measurement of free cyanide, simple alkali metals cyanides, and weakly complexed organometallic cyanide complexes. In order for the analytical method to be acceptable, the recovery of free cyanide from metal complexes must be comparable to that achieved by the approved method in 40 CFR Part 136, as revised May 14, 1999.
- 4 Chronic toxicity expressed as Chronic Toxicity Units (TUc) = 100/NOEL, where NOEL (No Observed Effect Level) is expressed as the maximum percent effluent or receiving water that causes no observable effect on a test organism.
- 5 Non-chlorinated phenolic compounds represent the sum of 2,4-dimethylphenol, 4,6-Dinitro-2-methylphenol, 2,4-dinitrophenol, 2-methylphenol, 4-methylphenol, 2-Nitrophenol, 4-nitrophenol, and phenol.
- 6 Chlorinated phenolic compounds represent the sum of 4-chloro-3-methylphenol, 2-chlorophenol, pentachlorophenol, 2,4,5-trichlorophenol, and 2,4,6-trichlorophenol.
- 7 Endosulfan represents the sum of alpha-endosulfan, beta-endosulfan, and endosulfan sulfate.
- 8 HCH (hexachlorocyclohexane) represents the sum of the alpha, beta, gamma (Lindane), and delta isomers of hexachlorocyclohexane.
- 9 Dichlorobenzenes represent the sum of 1,2- and 1,3-dichlorobenzene.
- 10 DDT represents the sum of 4,4'DDT; 2,4'DDT; 4,4'DDE; 2,4'DDE; 4,4'DDD; and 2,4'DDD.
- 11 Halomethanes represent the sum of bromoform, bromomethane (methyl bromide), and chloromethane (methyl chloride).
- 12 PAHs (polynuclear aromatic hydrocarbons) represent the sum of acenaphthalene; anthracene; 1,2-benzanthracene; 3,4-benzofluoranthene; benzo[k]fluoranthene; 1,12-benzoperylene; benzo[a]pyrene; chrysene; dibenzo[a,h]anthracene; fluorene; indeno[1,2,3-cd]pyrene; phenanthrene; and pyrene.

¹³ PCBs (polychlorinated biphenyls) represent the sum of chlorinated biphenyls whose analytical characteristics resemble those of Aroclor-1016, Aroclor-1221, Aroclor-1232, Aroclor-1242, Aroclor-1248, Aroclor-1254, and Aroclor-1260.

3. Interim Effluent Limitations – Not Applicable

B. Land Discharge Specifications – Not Applicable

C. Reclamation Specifications

FPUD must continue to comply with the separate reclamation requirements established in San Diego Water Board Order No. 91-39 and any applicable future revised or renewal waste discharge requirements, which are not incorporated by reference into this Order.

V. RECEIVING WATER LIMITATIONS

A. Surface Water Limitations

The receiving water limitations set forth below are based on water quality objectives contained in the Basin Plan and Ocean Plan and are a required part of this Order. The FPUD discharge shall not cause or contribute to the following in the Pacific Ocean.

1. Bacterial Characteristics

- a.** Within a zone bounded by the shoreline and a distance of 3 nautical miles from the shoreline, including all kelp beds, the following bacterial objectives shall be maintained throughout the water column. The zone of initial dilution for ocean outfall is excluded.

30-day Geometric Mean – The following standards are based on the geometric mean of the five most recent samples from each site:

- i.** Total coliform density shall not exceed 1,000 per 100 ml;
- ii.** Fecal coliform density shall not exceed 200 per 100 ml; and
- iii.** Enterococcus density shall not exceed 35 per 100 ml.

Single Sample Maximum:

- i.** Total coliform density shall not exceed 10,000 per 100 ml;
- ii.** Fecal coliform density shall not exceed 400 per 100 ml;
- iii.** Enterococcus density shall not exceed 104 per 100 ml; and
- iv.** Total coliform density shall not exceed 1,000 per 100 ml when the fecal coliform/total coliform ratio exceeds 0.1.

- b.** The Initial Dilution Zone for any wastewater outfall shall be excluded from designation as kelp beds for purposes of bacterial standards. Adventitious assemblages of kelp plants on waste discharge structures (e.g., outfall pipes and diffusers) do not constitute kelp beds for purposes of bacterial standards.

- c. At all areas where shellfish may be harvested for human consumption, as determined by the San Diego Water Board, the median total coliform density shall not exceed 70 per 100 ml throughout the water column, and not more than 10 percent of the samples shall exceed 230 per 100 ml.

2. Physical Characteristics

- a. Floating particulates and grease and oils shall not be visible.
- b. The discharge of waste shall not cause aesthetically undesirable discoloration of the ocean surface.
- c. Natural light shall not be significantly reduced at any point outside the initial dilution zone as a result of the discharge of waste.
- d. The rate of deposition of inert solids and the characteristics of inert solids in the ocean sediments shall not be changed such that benthic communities are degraded.

3. Chemical Characteristics

- a. The dissolved oxygen concentration shall not at any time be depressed more than 10 percent from that which occurs naturally, as the result of the discharge of oxygen demanding waste materials.
- b. The pH shall not be changed at any time more than 0.2 units from that which occurs naturally.
- c. The dissolved sulfide concentration of waters in and near sediments shall not be significantly increased above that present under natural conditions.
- d. The concentration of substances set forth in Chapter II, Table B of the Ocean Plan, shall not be increased in marine sediments to levels that would degrade indigenous biota.
- e. The concentration of organic materials in marine sediments shall not be increased to levels that would degrade marine life.
- f. Nutrient materials shall not cause objectionable aquatic growths or degrade indigenous biota.
- g. Numerical water quality objectives established in Section II, Table B of the California Ocean Plan shall not be exceeded outside of the zone of initial dilution as a result of the discharges from the Facility.

4. Biological Characteristics

- a. Marine communities, including vertebrate, invertebrate, and plant species, shall not be degraded.
- b. The natural taste, odor, color of fish, shellfish, or other marine resources used for human consumption shall not be altered.

- c. The concentration of organic materials in fish, shellfish, or other marine resources used for human consumption shall not bioaccumulate to levels that are harmful to human health.

5. Radioactivity

- a. Discharge of radioactive waste shall not degrade marine life.

B. Groundwater Limitations – Not Applicable

VI. PROVISIONS

A. Standard Provisions

1. **Federal Standard Provisions.** FPUD shall comply with all Standard Provisions included in Attachment D of this Order.
2. **San Diego Water Board Standard Provisions.** FPUD shall comply with the following provisions:
 - a. FPUD shall comply with all requirements and conditions of this Order. Any permit non-compliance may constitute a violation of the CWA and/or the CWC and may be grounds for enforcement action, permit termination, revocation and reissuance, or modification, or for denial of an application for permit renewal, modification, or reissuance.
 - b. FPUD shall comply with all applicable federal, State, and local laws and regulations that pertain to sewage sludge handling, treatment, use and disposal, including CWA section 405 and USEPA regulations at 40 CFR Part 257.
 - c. FPUD's wastewater treatment facilities shall be supervised and operated by persons possessing certificates of appropriate grade pursuant to Title 23, Division 3, Chapter 26 of the California Code of Regulations (CCR).
 - d. All proposed new treatment facilities and expansions of existing treatment facilities shall be completely constructed and operable prior to initiation of the discharge from the new or expanded facilities. FPUD shall submit a certification report for each new treatment facility, expansion of an existing treatment facility, and re-ratings, the certification report shall be prepared by the design engineer. For re-ratings, the certification report shall be prepared by the engineer who evaluated the treatment facility capacity. The certification report shall:
 - i. Identify the design capacity of the treatment facility, including the daily and 30-day design capacity,
 - ii. Certify the adequacy of each component of the treatment facility, and
 - iii. Contain a requirement-by-requirement analysis, based on acceptable engineering practices, of the process and physical design of the facility to ensure compliance with this Order.

- iv. Contain the signature and engineering license number of the engineer preparing the certification report affixed to the report. If reasonable, the certification report shall be submitted prior to beginning construction. FPUD shall not initiate a discharge from an existing treatment facility at a daily flow rate in excess of its previously approved design capacity until:
 - (1) The certification report is received by the San Diego Water Board,
 - (2) The San Diego Water Board has received written notification of completion of construction (new treatment facilities and expansions only),
 - (3) An inspection of the facility has been made by the San Diego Water Board or their designated representatives (new treatment facilities and expansions only), and
 - (4) The San Diego Water Board has provided FPUD with written authorization to discharge at a daily flow rate in excess of its previously approved design capacity.
- e. All waste treatment, containment, and disposal facilities shall be protected against 100-year peak stream flows as defined by the San Diego County flood control agency.
- f. All waste treatment, containment, and disposal facilities shall be protected against erosion, overland runoff, and other impacts resulting from a 100-year, 24-hour storm event.
- g. This Order expires on September 27, 2017, after which, the terms and conditions of this permit are automatically continued pending issuance of a new permit, provided that all requirements of USEPA's NPDES regulations at 40 CFR 122.6 and the State's regulations at CCR Title 23, section 2235.4 regarding the continuation of expired permits and waste discharge requirements are met.
- h. FPUD's wastewater treatment facilities shall be operated and maintained in accordance with the operations and maintenance manual prepared by FPUD pursuant to the Clean Water Grant Program. A copy of this manual shall be at or near the treatment and disposal facilities and shall be available to operating personnel at all times.
- i. A copy of this Order shall be posted at a prominent location at or near the treatment and disposal facilities and shall be available to operating personnel at all times.

B. Monitoring and Reporting Program (MRP) Requirements

FPUD shall comply with the MRP, and future revisions thereto, in Attachment E of this Order.

C. Special Provisions

1. Reopener Provisions

- a. This Order may be reopened for modification to include an effluent limitation if monitoring establishes that the discharge causes, has the reasonable potential to cause, or contributes to an excursion above an Ocean Plan Table B water quality objective.

- b.** This Order may be reopened for modification of the receiving waters monitoring requirements, as the San Diego Water Board determines. The modification(s) can include, but is (are) not limited to, recommendations from Southern California Coastal Water Research Project (SCCWRP) or creation of a Regional Monitoring Program.
- c.** This Order may be modified, revoked and reissued, or terminated for cause including, but not limited to, the following;
 - i.** Violation of any terms or conditions of this Order.
 - ii.** Obtaining this Order by misrepresentation or failure to disclose fully all relevant facts.
 - iii.** A change in any condition that requires either a temporary or permanent reduction or elimination of the authorized discharge.

The filing of a request by FPUD for modifications, revocation and reissuance, or termination of this Order does not stay any condition of this Order. Notification by FPUD of planned operational or facility changes, or anticipated noncompliance with this Order does not stay any condition of this Order.

- d.** If any applicable toxic effluent standard or prohibition (including any schedule of compliance specified in such effluent standard or prohibition) is promulgated under section 307 (a) of the CWA for a toxic pollutant and that standard or prohibition is more stringent than any limitation on the pollutant in this Order, the San Diego Water Board may institute proceedings under these regulations to modify or revoke and reissue the Order to conform to the toxic effluent standard or prohibition.
- e.** This Order may be re-opened and modified, to incorporate in accordance with the provisions set forth in 40 CFR Parts 122 and 124, to include requirements for the implementation of the watershed management approach.
- f.** This Order may be reopened and modified, in accordance with the provisions set forth in 40 CFR Parts 122 and 124, to include new Minimum Levels (MLs).
- g.** This Order may be re-opened and modified to revise effluent limitations as a result of future Basin Plan Amendments, or the adoption of a total maximum daily load (TMDL) for the receiving water.
- h.** This Order may be re-opened upon submission by FPUD of adequate information, as determined by this San Diego Water Board, to provide for dilution credits or a mixing zone, as may be appropriate.
- i.** This Order may be re-opened and modified to revise the toxicity language once that language becomes standardized.
- j.** This Order may also be re-opened and modified, revoked and reissued, or terminated in accordance with the provisions of 40 CFR 122.44, 122.62 to 122.64, 125.62, and 125.62. Causes for taking such actions include, but are not limited to, failure to comply with any condition of this Order and permit, and endangerment to human health or the environment resulting from the permitted activity.

2. Special Studies, Technical Reports and Additional Monitoring Requirements

a. Spill Prevention and Response Plans

- i. For purposes of this section, a spill is a discharge of treated or untreated wastewater that occurs at or downstream of the Facility headworks in violation of Discharge Prohibition III.A of this Order, or a discharge of other materials related to treatment and operations of the Facility. This section does not include sanitary sewer overflows (SSOs) from the sewage collection system that are reportable under separate waste discharge requirements, not incorporated herein.
- ii. FPUD shall maintain and implement a Spill Prevention Plan (SPP) for the facilities owned and/or operated by FPUD in an up-to-date condition and shall amend the SPP whenever there is a change (e.g., in the design, construction, operation, or maintenance of the sewerage system or sewerage facilities) which materially affects the potential for spills. FPUD shall review and amend the SPP as appropriate after each spill from the Facility. The SPP and any amendments thereto shall be subject to the approval of the San Diego Water Board and shall be modified as directed by the San Diego Water Board. FPUD shall submit the SPP and any amendments thereto to the San Diego Water Board upon request of the San Diego Water Board. FPUD shall ensure that the up-to-date SPP is readily available to the sewerage system personnel at all times and that the sewerage system personnel are familiar with it.
- iii. FPUD shall maintain and implement a Spill Response Plan (SRP) for the Facility in an up-to-date condition and shall amend the SRP, as necessary. FPUD shall review and amend the SRP as appropriate after each spill from the Facility. The SRP and any amendments thereto shall be subject to the approval of the San Diego Water Board and shall be modified as directed by the San Diego Water Board. FPUD shall submit the SRP and any amendments thereto to the San Diego Water Board upon request of the San Diego Water Board. FPUD shall ensure that the up-to-date SRP is readily available to the sewerage system personnel at all times and that the sewerage system personnel are familiar with it.

b. Spill Reporting Requirements

FPUD shall report treated and untreated wastewater spills downstream of the plant headworks as defined in section VI.C.2.a.i above in accordance with the following procedures:

- i. If a spill results in a discharge of treated or untreated wastewater downstream of the plant headworks that is equal to or exceeds 1,000 gallons, and/or results in a discharge to a drainage channel and/or surface water, and/or results in a discharge to a storm drain that was not fully captured and returned to the sanitary sewer system, FPUD shall:
 - (a) Report the spill to the San Diego Water Board by telephone, by voice mail, or by FAX within 24 hours from the time FPUD becomes aware of the spill. FPUD shall inform the San Diego Water Board of the date of the spill, spill location and its final destination, time the spill began and ended, estimated total spill volume, and type of spill material.

- (b) Submit a written report, as well as any additional pertinent information, to the San Diego Water Board no later than five days from the time FPUD becomes aware of the spill.
 - (c) The San Diego Water Board may waive the above-required written report under this provision on a case-by-case basis if an oral report has been received within 24 hours.
- ii. If a spill results in a discharge of treated or untreated wastewater under 1,000 gallons and the discharge does not reach a drainage channel, surface waters, or storm drain, or reached a storm drain but was fully captured, FPUD is not required to notify the San Diego Water Board within 24 hours or provide a five-day written report.
 - iii. For spills of material other than treated or untreated wastewater that cause, may cause, or are caused by significant operational failure, or endangers or may endanger human health or the environment, FPUD shall notify the San Diego Water Board by telephone, by voice mail, or by FAX within 24 hours from the time FPUD becomes aware of the spill. FPUD shall inform the San Diego Water Board of the date of the spill, spill location and its final destination, time the spill began and ended, estimated total spill volume, and type of spill material.
 - iv. For all spills, FPUD shall include a detailed summary of spills in the monthly self-monitoring report for the month in which the spill occurred.
 - v. The spill reporting requirements contained in this Order do not relieve FPUD of responsibilities to report to other agencies, such as the California Emergency Management Agency (EMA) and the County of San Diego Department of Environmental Health Services.

c. Toxicity Reduction Requirements

If the performance goal for acute or chronic toxicity is exceeded in any one test, then within 15 days of the exceedance, FPUD shall begin conducting six additional tests, bi-weekly, over a 12 week period.

If either toxicity performance goal is exceeded in any of these six additional tests, then FPUD shall notify the San Diego Water Board. If the San Diego Water Board determines that the discharge consistently exceeds a toxicity performance goal, then FPUD shall initiate a Toxicity Reduction Evaluation (TRE)/Toxicity Identification Evaluation (TIE) in accordance with the TRE workplan, *Toxicity Reduction Evaluation Guidance for Municipal Wastewater Treatment Plants* (USEPA 833-B-99-002, 1999), and USEPA TIE guidance documents (Phase I, EPA/600/6-91/005F, 1992; Phase II, EPA/600/R-92/080, 1993; and Phase III, EPA/600/R-92/081, 1993). Once the source of toxicity is identified, FPUD shall take all reasonable steps to reduce the toxicity to meet the chronic toxicity performance goal identified in section IV.A.2.a of this Order.

Within 30 days of completion of the TRE/TIE, FPUD shall submit the results of the TRE/TIE, including a summary of the findings, data generated, a list of corrective actions necessary to achieve consistent compliance with all the performance goals of this Order and prevent recurrence of exceedances of those performance goals, and a time schedule for implementation of such corrective actions. The corrective actions and time schedule shall be modified at the direction of the San Diego Water Board.

If no toxicity is detected in any of these additional six tests, then FPUD may return to the testing frequency specified in the MRP.

d. Toxicity Reduction Evaluation (TRE)

FPUD shall review and update, as necessary, its TRE workplan in accordance with TRE procedures established by USEPA in the following guidance manuals.

- i. *Generalized Methodology for Conducting Industrial Toxicity Reduction Evaluations* (EPA/600/2-88/070).
- ii. *Toxicity Identification Evaluation, Phase I* (EPA/600/6-91/005F).
- iii. *Methods for Aquatic Toxicity Identification Evaluations, Phase II* (EPA/600/R-92/080).
- iv. *Methods for Aquatic Toxicity Identification Evaluations, Phase III* (EPA/600/R-92/081).

FPUD shall submit any revisions to its TRE workplan to the San Diego Water Board within 180 days of the adoption of this Order. The TRE workplan shall be subject to the approval of the San Diego Water Board and shall be modified as directed by the San Diego Water Board.

3. Best Management Practices and Pollution Prevention – Not Applicable

4. Construction, Operation and Maintenance Specifications – Not Applicable

5. Special Provisions for Wastewater Facilities (POTWs Only)

a. Treatment Plant Capacity

FPUD shall submit a written report to the San Diego Water Board within 90 days after the monthly average influent flow rate equals or exceeds 75 percent of the secondary treatment design capacity of the wastewater treatment and/or disposal facilities. FPUD's senior administrative officer shall sign a letter in accordance with Standard Provision V.B. (Attachment D of this Order) which transmits that report and certifies that that policy-making body is adequately informed of the influent flow rate relative to the Facility's design capacity. The report shall include the following:

- i. Average influent daily flow for the calendar month, the date on which the maximum daily flow occurred, and the rate of that maximum flow.
- ii. FPUD's best estimate of when the average daily influent flow for a calendar month will equal or exceed the design capacity of the facilities.
- iii. FPUD's intended schedule for studies, design, and other steps needed to provide additional treatment for the wastewater from the collection system before the waste flow exceeds the capacity of present units.

b. Pretreatment Program

- i. FPUD shall conduct an Industrial Waste Survey (IWS) of all the industrial users (IUs) in the service area of the Facility to determine whether any IUs are subject to pretreatment standards specified in 40 CFR Part 403. FPUD shall also perform a priority pollutant scan of the influent to the Facility. The IWS and priority pollutant monitoring is required during the 12-month period beginning on November 1, 2013. Based on results of the IWS, the priority pollutant scan, and the requirements of 40 CFR Part 403, FPUD shall submit a certification report indicating whether the Facility receives pollutants from any IU that would require FPUD to establish a pretreatment program in accordance with 40 CFR Part 403. The certification report, along with results of the IWS and priority pollutant monitoring, shall be submitted to the San Diego Water Board by December 1, 2014. If FPUD becomes aware of an IU in the service area of the Facility that would require development of a pretreatment program pursuant to 40 CFR Part 403, FPUD shall notify the San Diego Water Board and request a modification of this Order to include pretreatment program requirements. In such circumstances, FPUD shall develop and implement a pretreatment program in accordance with the requirements of CWA sections 307(b) and (c) and 402(b)(8) and 40 CFR Part 403. FPUD shall assure compliance with applicable federal and local pretreatment standards by the IUs within the service area of the Facility.
- ii. The San Diego Water Board may amend this Order, at any time, to require FPUD to develop and implement an industrial pretreatment program pursuant to the requirements of 40 CFR Part 403 if the San Diego Water Board finds that the Facility receives pollutants from an IU that is subject to pretreatment standards, or if other circumstances so warrant.

c. Sludge (Biosolids) Disposal Requirements

- i. The handling, treatment, use, management, and disposal of sludge and solids derived from wastewater treatment must comply with applicable provisions of CWA section 405 and USEPA regulations at 40 CFR Parts 257, 258, 501, and 503, including all monitoring, record keeping, and reporting requirements.
- ii. Sludge and wastewater solids must be disposed of in a municipal solid waste landfill, reused by land application, or disposed of in a sludge-only landfill in accordance with 40 CFR Parts 258 and 503 and Title 23, Chapter 15 of the CCR. If FPUD desires to dispose of solids and/or sludge in a different manner, a request for permit modification must be submitted to the USEPA and the San Diego Water Board at least 180 days prior to beginning the alternative means of disposal.
- iii. Sludge that is disposed of in a municipal solid waste landfill must meet the requirements of 40 CFR Part 258 pertaining to providing information to the public. In the annual self-monitoring report, FPUD shall include the amount of sludge placed in the landfill as well as the landfill to which it was sent.
- iv. All requirements of 40 CFR Part 503 and 23 CCR Chapter 15 are enforceable whether or not the requirements of those regulations are stated in an NPDES permit or any other permit issued to FPUD.

- v. FPUD shall take all reasonable steps to prevent and minimize any sludge use or disposal in violation of this Order that has a likelihood of adversely affecting human health or the environment.
- vi. Solids and sludge treatment, storage, and disposal or reuse shall not create a nuisance, such as objectionable odors or flies, and shall not result in groundwater contamination.
- vii. The solids and sludge treatment and storage site shall have adequate facilities to divert surface water runoff from adjacent areas to protect the boundaries of the site from erosion, and to prevent drainage from the treatment and storage site. Adequate protection is defined as protection, at the minimum, from a 100-year storm and protection from the highest possible tidal stage that may occur.
- viii. The discharge of sewage sludge and solids shall not cause waste material to be in position where it is, or can be, conveyed from the treatment and storage sites and deposited in waters of the State.
- ix. FPUD shall submit an annual report to the USEPA and the San Diego Water Board containing monitoring results and pathogen and vector attraction reduction requirements, as specified by 40 CFR Part 503. FPUD shall also report the quantity of sludge removed from the Facility and the disposal method. This self-monitoring report shall be postmarked by February 19 of each year and report for the period of the previous calendar year.

d. Collection System

On May 2, 2006, the State Water Board adopted State Water Board Order No. 2006-0003, a Statewide General WDR for Sanitary Sewer Systems. Order No. 2006-0003 requires that all public agencies that currently own or operate sanitary sewer systems apply for coverage under the General WDR. FPUD shall be subject to all applicable requirements of Order No. 2006-0003 and any future revisions thereto, the requirements of which are not incorporated herein.

Regardless of the coverage obtained under Order No. 2006-0003, FPUD's collection system is part of the treatment system that is subject to this Order. As such, pursuant to federal regulations, FPUD must properly operate and maintain its collection system [40 CFR 122.41(e)], report any non-compliance [40 CFR 122.41(l)(6) and (7)], and mitigate or prevent any discharge from the collection system in violation of this Order [40 CFR 122.41(d)].

6. Other Special Provisions – Not Applicable

7. Compliance Schedules

Prior to terminating disinfection of the Facility effluent, FPUD must submit a plan and time schedule that outlines the tasks and approaches to achieve full compliance with bacteria receiving water limitations, contained within the Ocean Plan, outside of the initial dilution zone of the Oceanside OO. The time schedule shall include timelines for design, construction and implementation of any new or improved facilities needed for compliance.

VII. COMPLIANCE DETERMINATION

Unless otherwise provided for by this Order, such as Standard Provisions I.G and I.H of Attachment D, or for just cause to decide otherwise, compliance with the effluent limitations contained in section IV of this Order will be determined as specified below:

A. Compliance with Average Monthly Effluent Limitation (AMEL)

If the average of daily discharges over a calendar month exceeds the AMEL for a given parameter, an alleged violation will be flagged and FPUD will be considered out of compliance for each day of that month for that parameter (e.g., resulting in 31 days of noncompliance in a 31-day month). The average of daily discharges over the calendar month that exceeds the AMEL for a parameter will be considered out of compliance for the month only. If only a single sample is taken during the calendar month and the analytical result for that sample exceeds the AMEL, FPUD will be considered out of compliance for that calendar month. For any one calendar month during which no sample (daily discharge) is taken, no compliance determination can be made for that calendar month.

B. Compliance with Average Weekly Effluent Limitation (AWEL)

If the average of daily discharges over a calendar week (Sunday through Saturday) exceeds the AWEL for a given parameter, an alleged violation will be flagged and FPUD will be considered out of compliance for each day of that week for that parameter, resulting in 7 days of noncompliance. The average of daily discharges over the calendar week that exceeds the AWEL for a parameter will be considered out of compliance for that week only. If only a single sample is taken during the calendar week and the analytical result for that sample exceeds the AWEL, FPUD will be considered out of compliance for that calendar week. For any one calendar week during which no sample (daily discharge) is taken, no compliance determination can be made for that calendar week.

C. Compliance with Maximum Daily Effluent Limitation (MDEL)

The MDEL shall apply to flow weighted 24-hour composite samples, or grab, as specified in the MRP (Attachment E of this Order). If a daily discharge exceeds the MDEL for a given parameter, an alleged violation will be flagged and FPUD will be considered out of compliance for that parameter for that one day only within the reporting period. For any one day during which no sample is taken, no compliance determination can be made for that day.

D. Compliance with Instantaneous Minimum Effluent Limitation

The instantaneous minimum effluent concentration limitation shall apply to grab sample determinations. If the analytical result of a single grab sample is lower than the instantaneous minimum effluent limitation for a parameter, a violation will be flagged and FPUD will be considered out of compliance for that parameter for that single sample. Non-compliance for each sample will be considered separately (e.g., the results of two grab samples taken within a calendar day that both are lower than the instantaneous minimum effluent limitation would result in two instances of noncompliance with the instantaneous minimum effluent limitation.)

E. Compliance with Instantaneous Maximum Effluent Limitation

The instantaneous maximum effluent concentration limitation shall apply to grab sample determinations. If the analytical result of a single grab sample is higher than the instantaneous maximum effluent limitation for a parameter, a violation will be flagged and FPUD will be considered out of compliance for that parameter for that single sample. Non-compliance for each sample will be considered separately (e.g., the results of two grab samples taken within a calendar day that both are lower than the instantaneous minimum effluent limitation would result in two instances of noncompliance with the instantaneous minimum effluent limitation.)

F. Compliance with 6-Month Median Effluent Limitation

If the median of daily discharges over any 180-day period exceeds the 6-month median effluent limitation for a given parameter, an alleged violation will be flagged and FPUD will be considered out of compliance for each day of that 180-day period for that parameter. The next assessment of compliance will occur after the next sample is taken. If only a single sample is taken during a given 180-day period and the analytical result for that sample exceeds the 6-month median, FPUD will be considered out of compliance for the 180-day period. For any 180-day period during which no sample is taken, no compliance determination can be made for the 6-month median limitation.

G. Mass and Concentration Limitations

Compliance with mass and concentration effluent limitations for the same parameter shall be determined separately with their respective limitations. When the concentration of a constituent in an effluent sample is determined to be “Not Detected” (ND) or “Detectable but not quantifiable” (DNQ), the corresponding mass emission rate (MER) determined from that sample concentration shall also be reported as “ND” or “DNQ”.

H. Percent Removal

Compliance with percent removal requirements for monthly average percent removal of carbonaceous biochemical oxygen demand and total suspended solids shall be determined separately for each wastewater treatment facility discharging through an outfall. For each wastewater treatment facility, the monthly average percent removal is the average of the calculated daily discharge percent removals only for days on which the constituent concentration is monitored in both the influent and effluent of the wastewater treatment facility at location specified in the MRP (Attachment E of this Order) within a calendar month.

The percent removal for each day shall be calculated according to the following equation:

$$\text{Daily discharge percent removal} = \frac{\text{Influent concentration} - \text{Effluent concentration}}{\text{Influent concentration}} \times 100\%$$

I. Ocean Plan Provisions for Table B Constituents

1. Sampling Reporting Protocols

- a. FPUD must report with each sample result the reported Minimum Level (ML) and the laboratory’s current Method Detection Limit (MDL).

- b.** FPUD must also report results of analytical determinations for the presence of chemical constituents in a sample using the following reporting protocols:
 - i.** Sample results greater than or equal to the reported ML must be reported “as measured” by the laboratory (i.e., the measured chemical concentration in the sample).
 - ii.** Sample results less than the reported ML, but greater than or equal to the laboratory’s MDL, must be reported as “Detected, but Not Quantified”, or DNQ. The laboratory must write the estimated chemical concentration of the sample next to DNQ as well as the words “Estimated Concentration” (may be shorted to “Est. Conc.”).
 - iii.** Sample results less than the laboratory’s MDL must be reported as “Not Detected”, or ND.

2. Compliance Determination

Sufficient sampling and analysis shall be required to determine compliance with the effluent limitation.

a. Compliance with Single-constituent Effluent Limitations

FPUD shall be deemed out of compliance with an effluent limitation or discharge specification if the concentration of the constituent in the monitoring sample is greater than the effluent limitation or discharge specification and greater than or equal to the ML.

b. Compliance with Effluent Limitations Expressed as a Sum of Several Constituents

FPUD is out of compliance with an effluent limitation that applies to the sum of a group of chemicals (e.g., PCBs) if the sum of the individual pollutant concentrations is greater than the effluent limitation. Individual pollutants of the group will be considered to have a concentration of zero if the constituent is reported as ND or DNQ.

c. Multiple Sample Data Reduction

The concentration of the pollutant in the effluent may be estimated from the result of a single sample analysis or by a measure of central tendency (arithmetic mean, geometric mean, median, etc.) of multiple sample analyses when all sample results are quantifiable (i.e., greater than or equal to the reported ML). When one or more sample results are reported as ND or DNQ, the central tendency concentration of the pollutant shall be the median (middle) value of the multiple samples. If, in an even number of samples, one or both of the middle values is ND or DNQ, the median will be the lower of the two middle values.

d. Mass Emission Rate

The mass emission rate (MER), in pounds per day, shall be obtained from the following calculation for any calendar day:

$$\text{Mass Emission Rate (lb/day)} = 8.34 \times Q \times C$$

In which Q and C are the flow rate in million gallons per day and the constituent concentration in mg/L, respectively, and 8.34 is a conversion factor (lb/gallon of water). If a composite sample is taken, then C is the concentration measured in the composite sample and Q is the average flow rate occurring during the period over which the samples are composited.

e. Bacterial Standards and Analysis

- i. The geometric mean used for determining compliance with bacterial standards is calculated with the following equation:

$$\text{Geometric Mean} = (C_1 \times C_2 \times \dots \times C_n)^{1/n}$$

Where n is the number of days samples were collected during the period and C is the concentration of bacteria (CFU/100 mL) found on each day of sampling.

- ii. For all bacterial analyses, sample dilutions should be performed so the range of values extends from 2 to 16,000 CFU (colony-forming units). The detection methods used for each analysis shall be reported with the results of the analysis. Detection methods used for coliforms (total and fecal) shall be those listed in 40 CFR Part 136 or any improved method determined by the San Diego Water Board (and approved by USEPA) to be appropriate. Detection methods used for enterococcus shall be those presented in USEPA publication USEPA 600/4-85/076, *Test Methods for Escherichia coli and Enterococci in Water by Membrane Filter Procedure*, listed under 40 CFR Part 136, or any other method approved by the San Diego Water Board.

f. Single Operational Upset

A single operational upset (SOU) that leads to simultaneous violations or more than one pollutant parameter shall be treated as a single violation and limits FPUD's liability in accordance with the following conditions:

- i. A SOU is broadly defined as a single unusual event that temporarily disrupts the usually satisfactory operation of a system in such a way that it results in violation of multiple pollutant parameters.
- ii. A Discharger may assert SOU to limit liability only for those violations which FPUD submitted notice of the upset as required in Section I.H of Attachment D of this Order.
- iii. For purposes outside of CWC section 13385(h) and (i), determination of compliance and civil liability (including any more specific definition of SOU), the requirements for Dischargers to assert the SOU limitation of liability, and the manner of counting violations, shall be in accordance with the USEPA Memorandum "Issuance of Guidance Interpreting Single Operational Upset" (September 27, 1989).
- iv. For purposes of CWC section 13385(h) and (i), determination of compliance and civil liability (including any more specific definition of SOU, the requirements for Dischargers to assert the SOU) limitation of liability, and the manner of counting violations shall be in accordance with CWC section 13385(f)(2).

J. Chronic Toxicity

Chronic toxicity is used to measure the acceptability of waters for supporting a healthy marine biota until approved methods are developed to evaluate biological response. Evaluation of the chronic toxicity performance goal established in section IV.A.2 of this Order for Discharge Point No. 001 shall be determined using critical life stage toxicity tests in accordance with procedures prescribed by the Ocean Plan and restated in the MRP (Attachment E of this Order). Chronic toxicity shall be expressed as Toxic Units Chronic (TUC), where:

$$TUC = 100 / NOEL$$

where NOEL is the No Observed Effect Level and is expressed as the maximum percent of effluent that causes no observable effect on a test organism, as determined by the result of a critical life stage toxicity test.

ATTACHMENT A – DEFINITIONS

Acute Toxicity

- a. Acute Toxicity (TUa)
Expressed in Toxic Units Acute (TUa)

$$TUa = \frac{100}{96\text{-hr } LC_{50}}$$

- b. Lethal Concentration 50% (LC_{50})

LC_{50} (percent waste giving 50% survival of test organisms) shall be determined by static or continuous flow bioassay techniques using standard marine test species as specified in 2009 California Ocean Plan (hereinafter Ocean Plan) Appendix III. If specific identifiable substances in wastewater can be demonstrated by the discharger as being rapidly rendered harmless upon discharge to the marine environment, but not as a result of dilution, the LC_{50} may be determined after the test samples are adjusted to remove the influence of those substances.

When it is not possible to measure the 96-hour LC_{50} due to greater than 50 percent survival of the test species in 100 percent waste, the toxicity concentration shall be calculated by the expression:

$$TUa = \frac{\log(100 - S)}{1.7}$$

where:

S = percentage survival in 100% waste. If S > 99, TUa shall be reported as zero.

Anti-Backsliding

Provisions in the Clean Water Act (CWA) and USEPA regulations [CWA 303 (d) (4); CWA 402 (o); Code of Federal Regulations (CFR) 122.44 (I)] require a reissued permit to be as stringent as the previous permit with some exceptions.

Antidegradation

Policies which ensure protection of water quality for a particular body where the water quality exceeds levels necessary to protect fish and wildlife propagation and recreation on and in the water. This also includes special protection of waters designated as outstanding natural resource waters.

Antidegradation plans are adopted by the State to minimize adverse effects on water.

Applicable Standards and Limitations

All State, interstate, and federal water quality standards and limitations to which a discharge, a sewage sludge use or disposal practice, or a related activity is subject under the CWA, including effluent limitations, water quality standards, standards of performance, toxic effluent standards or prohibitions, best management practices, pretreatment standards, and standards for sewage sludge use or disposal under sections 301, 302, 303, 304, 306, 307, 308, 403, and 405 of CWA.

Areas of Special Biological Significance (ASBS)

Those areas designated by the State Water Board as ocean areas requiring protection of species or biological communities to the extent that alteration of natural water quality is undesirable. All Areas of

Special Biological Significance are also classified as a subset of STATE WATER QUALITY PROTECTION AREAS.

Average Monthly Effluent Limitation (AMEL)

The highest allowable average of daily discharges over a calendar month, calculated as the sum of all daily discharges measured during a calendar month divided by the number of daily discharges measured during that month.

Average Weekly Effluent Limitation (AWEL)

The highest allowable average of daily discharges over a calendar week (Sunday through Saturday), calculated as the sum of all daily discharges measured during a calendar week divided by the number of daily discharges measured during that week.

Beneficial Uses of waters of the State may be protected against quality degradation include, but are not limited to, domestic, municipal, agricultural and industrial supply; power generation; recreation; aesthetic enjoyment; navigation; and preservation and enhancement of fish, wildlife, and other aquatic resources or preserves.

Best Management Practices (BMPs)

Schedules of activities, prohibitions of practices, maintenance procedures, and other management practices to prevent or reduce the pollution of waters of the United States. BMPs also include treatment requirements, operating procedures, and practices to control plant site runoff, spillage or leaks, sludge or waste disposal, or drainage from raw material storage.

Best Professional Judgment (BPJ)

The method used by permit writers to develop technology-based NPDES permit conditions on a case-by-case basis using all reasonably available and relevant data.

Bioaccumulative Pollutants

Those substances taken up by an organism from its surrounding medium through gill membranes, epithelial tissue, or from food and subsequently concentrated and retained in the body of the organism.

Bioassay

A test used to evaluate the relative potency of a chemical or a mixture of chemicals by comparing its effect on a living organism with the effect of a standard preparation on the same type of organism.

Biosolids

Sewage sludge that is used or disposed through land application, surface disposal, incineration, or disposal in a municipal solid waste landfill.

Carbonaceous Biochemical Oxygen Demand (CBOD)

The measurement of oxygen required for carbonaceous oxidation of a nonspecific mixture of organic compounds. Interference caused by nitrifying bacteria in the standard 5-day BOD test is eliminated by suppressing the nitrification reaction.

Certifying Official

All applications, including notices of intent (NOIs), must be signed as follows:

For a municipality, state, federal, or other public agency: By either a principal executive officer or ranking elected official. A principal executive officer of a federal agency includes (i) the chief executive

officer of the agency, or (ii) a senior executive officer having responsibility for the overall operations of a principal geographic unit of the agency.

Chemical Oxygen Demand (COD)

A measure of the oxygen-consuming capacity of inorganic and organic matter present in wastewater. COD is expressed as the amount of oxygen consumed in mg/L. Results do not necessarily correlate to the biochemical oxygen demand (BOD) because the chemical oxidant may react with substances that bacteria do not stabilize.

Chlordane

Shall mean the sum of chlordane-alpha, chlordane-gamma, chlordene-alpha, chlordene-gamma, nonachlor-alpha, nonachlor-gamma, and oxychlordane.

Chronic Toxicity

This parameter shall be used to measure the acceptability of waters for supporting a healthy marine biota until improved methods are developed to evaluate biological response.

- a. Chronic Toxicity (TUc)

Expressed as Toxic Units Chronic (TUc)

$$TUc = \frac{100}{NOEL}$$

- b. No Observed Effect Level (NOEL)

The NOEL is expressed as the maximum percent effluent or receiving water that causes no observable effect on a test organism, as determined by the result of a critical life stage toxicity test listed in Ocean Plan Appendix III.

Composite Sample

Sample composed of two or more discrete samples of at least 100 milliliters collected at periodic intervals during the operating hours of a facility over a 24-hour period. The aggregate sample will reflect the average water quality covering the compositing or sample period. For volatile pollutants, aliquots must be combined in the laboratory immediately before analysis. The composite must be flow proportional; either the time interval between each aliquot or the volume of each aliquot must be proportional to either stream flow at the time of sampling or the total stream flow since the collection of the previous aliquot. Aliquots may be collected manually or automatically.

Conventional Pollutants

Pollutants typical of municipal sewage, and for which municipal secondary treatment plants are typically designed; defined at 40 CFR 401.16 as BOD, Total Suspended Solids (TSS), fecal coliform bacteria, oil and grease, and pH.

Daily Discharge

Daily Discharge is defined as either: (1) the total mass of the constituent discharged over the calendar day (12:00 am through 11:59 pm) or any 24-hour period that reasonably represents a calendar day for purposes of sampling (as specified in the permit), for a constituent with limitations expressed in units of mass or; (2) the unweighted arithmetic mean measurement of the constituent over the day for a constituent with limitations expressed in other units of measurement (e.g., concentration).

The daily discharge may be determined by the analytical results of a composite sample taken over the course of one day (a calendar day or other 24-hour period defined as a day) or by the arithmetic mean of analytical results from one or more grab samples taken over the course of the day.

For composite sampling, if 1 day is defined as a 24-hour period other than a calendar day, the analytical result for the 24-hour period will be considered as the result for the calendar day in which the 24-hour period ends.

Daily Maximum Limit

The maximum allowable daily discharge of pollutant. Where daily maximum limitations are expressed in units of mass, the daily discharge is the total mass discharged over the course of the 24-hour period. Where daily maximum limitations are expressed in terms of a concentration, the daily discharge is the arithmetic average measurement of the pollutant concentration derived from all measurements taken that 24-hour period.

DDT

Shall mean the sum of 4,4'DDT, 2,4'DDT, 4,4'DDE, 2,4'DDE, 4,4'DDD, and 2,4'DDD.

Degrade (Degradation)

Degradation shall be determined by comparison of the waste field and reference site(s) for characteristic species diversity, population density, contamination, growth anomalies, debility, or supplanting of normal species by undesirable plant and animal species. Degradation occurs if there are significant differences in any of three major biotic groups, namely, demersal fish, benthic invertebrates, or attached algae. Other groups may be evaluated where benthic species are not affected, or are not the only ones affected.

Detected, but Not Quantified (DNQ)

Sample results that are less than the reported Minimum Level, but greater than or equal to the laboratory's method detection limit (MDL).

Dilution Credit

The amount of dilution granted to a discharge in the calculation of a water quality-based effluent limitation, based on the allowance of a specified mixing zone. It is calculated from the dilution ratio or determined through conducting a mixing zone study or modeling of the discharge and receiving water.

Dichlorobenzenes

Shall mean the sum of 1,2- and 1,3-dichlorobenzene.

Discharge when used without qualification means the discharge of a pollutant. Discharge of a pollutant means:

1. Any addition of any pollutant or combination of pollutants to waters of the United States from any point source, or
2. Any addition of any pollutant or combination of pollutants to the waters of the contiguous zone or the ocean from any point source other than a vessel or other floating craft that is being used as a means of transportation.

This definition includes additions of pollutants into waters of the United States from: surface runoff which is collected or channeled by man; discharges through pipes, sewers, or other conveyances

owned by a state, municipality, or other person which do not lead to a treatment works; and discharges through pipes, sewers, or other conveyances, leading into privately owned treatment works. This term does not include an addition of pollutants by any indirect Discharger.

Discharge Monitoring Report (DMR) means the USEPA uniform form, including any subsequent additions, revisions, or modifications for the reporting of self-monitoring results by permittees. DMRs must be used by approved states as well as by USEPA. The USEPA will supply DMRs to any approved state upon request. The USEPA national forms may be modified to substitute the state agency name, address, logo, and other similar information, as appropriate, in place of USEPA's.

Downstream Ocean Waters

Waters downstream or down current with respect to ocean currents.

Dredged Material

Any material excavated or dredged from the navigable waters of the United States, including material otherwise referred to as "spoil".

Effluent Limitation

Any restriction imposed by an Order on quantities, discharge rates, and concentrations of pollutants that are discharged from point sources into waters of the United States, the waters of the contiguous zone, or the ocean, except performance goals.

Endosulfan

The sum of endosulfan-alpha and -beta and endosulfan sulfate.

Grab Sample

An individual sample of at least 100 milliliters collected at a randomly selected time over a period not exceeding 15 minutes. The sample is taken from a waste stream on a one-time basis without consideration of the flow rate of the waste stream and without consideration of time of day.

Halomethanes shall mean the sum of bromoform, bromomethane (methyl bromide), and chloromethane (methyl chloride).

HCH shall mean the sum of the alpha, beta, gamma (Lindane), and delta isomers of hexachlorocyclohexane.

Initial Dilution

The process that results in the rapid and irreversible turbulent mixing of wastewater with ocean water around the point of discharge.

For a submerged buoyant discharge, characteristic of most municipal and industrial wastes that are released from the submarine outfalls, the momentum of the discharge and its initial buoyancy act together to produce turbulent mixing. Initial dilution in this case is completed when the diluting wastewater ceases to rise in the water column and first begins to spread horizontally.

For shallow water submerged discharges, surface discharges, and non-buoyant discharges, characteristic of cooling water wastes and some individual discharges, turbulent mixing results primarily from the momentum of discharge. Initial dilution, in these cases, is considered to be completed when the momentum induced velocity of the discharge ceases to produce significant mixing of the waste, or the diluting plume reaches a fixed distance from the discharge to be specified by the San Diego Water Board, whichever results in the lower estimate for initial dilution.

Instantaneous Maximum Effluent Limitation

The highest allowable value for any single grab sample or aliquot (i.e., each grab sample or aliquot is independently compared to the instantaneous maximum limitation).

Instantaneous Minimum Effluent Limitation

The lowest allowable value for any single grab sample or aliquot (i.e., each grab sample or aliquot is independently compared to the instantaneous minimum limitation).

Kelp Beds

For purposes of the bacteriological standards of the Ocean Plan, are significant aggregations of marine algae of the genera Macrocystis and Nereocystis. Kelp beds include the total foliage canopy of Macrocystis and Nereocystis plants throughout the water column.

Maximum Daily Effluent Limitation (MDEL)

The highest allowable daily discharge of a pollutant.

Method Detection Limit (MDL)

The minimum concentration of a substance that can be measured and reported with 99 percent confidence that the analyte concentration is greater than zero, as defined in Title 40 of the Code of Federal Regulations (CFR), Part 136, Attachment B.

Minimum Level (ML)

The concentration at which the entire analytical system must give a recognizable signal and acceptable calibration point. The ML is the concentration in a sample that is equivalent to the concentration of the lowest calibration standard analyzed by a specific analytical procedure, assuming that all the method specified sample weights, volumes, and processing steps have been followed.

Natural Light

Reduction of natural light may be determined by the San Diego Water Board by measurement of light transmissivity or total irradiance, or both, according to the monitoring needs of the San Diego Water Board.

Not Detected (ND)

Those sample results less than the laboratory's MDL.

Nuisance

CWC section 13050, subdivision (m), defines nuisance as anything which meets all of the following requirements:

1. Is injurious to health, or is indecent or offensive to the senses, or an obstruction to the free use of property, so as to interfere with the comfortable enjoyment of life or property.
2. Affects at the same time an entire community or neighborhood, or any considerable number of persons, although the extent of the annoyance or damage inflicted upon individuals may be unequal.
3. Occurs during, or as a result of, the treatment or disposal of wastes.

Ocean Waters

The territorial marine waters of the State as defined by California law to the extent these waters are outside of enclosed bays, estuaries, and coastal lagoons. If a discharge outside the territorial waters of the State could affect the quality of the waters of the State, the discharge may be regulated to assure no violation of the Ocean Plan will occur in ocean waters.

PAHs (polynuclear aromatic hydrocarbons)

The sum of acenaphthylene, anthracene, 1,2-benzanthracene, 3,4-benzofluoranthene, benzo[k]fluoranthene, 1,12-benzoperylene, benzo[a]pyrene, chrysene, dibenzo[ah]anthracene, fluorene, indeno[1,2,3-cd]pyrene, phenanthrene, and pyrene.

PCBs (polychlorinated biphenyls)

The sum of chlorinated biphenyls whose analytical characteristics resemble those of Aroclor-1016, Aroclor-1221, Aroclor-1232, Aroclor-1242, Aroclor-1248, Aroclor-1254, and Aroclor-1260.

Pollutant Minimization Program (PMP)

PMP means waste minimization and pollution prevention actions that include, but are not limited to, product substitution, waste stream recycling, alternative waste management methods, and education of the public and businesses. The goal of the PMP shall be to reduce all potential sources of Ocean Plan Table B pollutants through pollutant minimization (control) strategies, including pollution prevention measures as appropriate, to maintain the effluent concentration at or below the water quality-based effluent limitation. Pollution prevention measures may be particularly appropriate for persistent bioaccumulative priority pollutants where there is evidence that beneficial uses are being impacted. The San Diego Water Board may consider cost effectiveness when establishing the requirements of a PMP. The completion and implementation of a Pollution Prevention Plan, if required pursuant to CWC section 13263.3(d), shall be considered to fulfill the PMP requirements.

Publicly Owned Treatment Works (POTW)

The term Publicly Owned Treatment Works or POTW means a treatment works as defined by section 212 of the Clean Water Act, which is owned by a State or municipality [as defined by section 502(4) of the Act]. This definition includes any devices and systems used in the storage, treatment, recycling, and reclamation of municipal sewage or industrial wastes of a liquid nature. It also includes sewers, pipes, and other conveyances only if they convey wastewater to a POTW Treatment Plant. The term also means the municipality as defined in section 502(4) of the Act, which has jurisdiction over the Indirect Discharges to and the discharges from such a treatment works.

POTW Treatment Plant

The term POTW Treatment Plant means that portion of the POTW which is designed to provide treatment (including recycling and reclamation) of municipal sewage and industrial waste.

Reported Minimum Level

The ML (and its associated analytical method) chosen by the Discharger for reporting and compliance determination from the MLs included in this Order. The MLs included in this Order correspond to approved analytical methods for reporting a sample result that are selected by the San Diego Water Board either from Appendix II of the Ocean Plan in accordance with section III.C.5.a of the Ocean Plan or established in accordance with section III.C.5.b of the Ocean Plan. The ML is based on the proper application of method-based analytical procedures for sample preparation and the absence of any matrix interferences. Other factors may be applied to the ML depending on the specific sample preparation steps employed. For example, the treatment typically applied in cases where there are matrix-effects is to dilute the sample or sample aliquot by a factor of ten. In such cases, this additional factor must be applied to the ML in the computation of the reported ML.

Sanitary Sewer Overflow (SSO)

Any overflow, spill, release, discharge, or diversion of untreated or partially treated wastewater from a sanitary sewer system. SSOs include:

1. Overflows or releases of untreated or partially treated wastewater that reach waters of the United States;
2. Overflows or releases of untreated or partially treated wastewater that do not reach waters of the United States; and
3. Wastewater backups into buildings and on private property that are caused by blockages or flow conditions within the publicly/federally-owned portion of a sanitary sewer system.

Sanitary Sewer System

Any system of pipes, pump stations, sewer lines, or other conveyances, upstream of a wastewater treatment plant headworks used to collect and convey wastewater to the wastewater treatment facility. Temporary storage and conveyance facilities (such as vaults, temporary piping, construction trenches, wet wells, impoundments, tanks, etc.) are considered to be part of the sanitary sewer system, and discharges into these temporary storage facilities are not considered to be SSOs

Secondary Treatment Standards

Technology-based requirements for direct discharging municipal sewage treatment facilities. Standards are based on a combination of physical and biological processes typical for the treatment of pollutants in municipal sewage. Standards are expressed as a minimum level of effluent quality in terms of: BOD₅, TSS, and pH (except as provided for special considerations and treatment equivalent to secondary treatment).

Sewage Sludge

Sewage sludge means any solid, semi-solid, or liquid residue removed during the treatment of municipal waste water or domestic sewage. Sewage sludge includes, but is not limited to, solids removed during primary, secondary, or advanced waste water treatment, scum, septage, portable toilet pumpings, type III marine sanitation device pumpings (33 CFR Part 159), and sewage sludge products. Sewage sludge does not include grit or screenings, or ash generated during the incineration of sewage sludge. [40 CFR 122.2]

Shellfish

Organisms identified by the State of California Department of Public Health as shellfish for public health purposes (i.e., mussels, clams, and oysters).

Significant Difference

Defined as a statistically significant difference in the means of two distributions of sampling results at the 95 percent confidence level.

Six-month Median Effluent Limitation

The highest allowable moving median of all daily discharges for any 180-day period.

State Water Quality Protection Areas (SWQPAs)

Non-terrestrial marine or estuarine areas designated to protect marine species or biological communities from an undesirable alteration in natural water quality. All AREAS OF SPECIAL BIOLOGICAL SIGNIFICANCE (ASBS) that were previously designated by the State Water Board in Resolution Nos. 74-28, 74-32, and 75-61 are now also classified as a subset of State Water Quality Protection Areas and require special protections afforded by the Ocean Plan.

Technology-Based Effluent Limit

A permit limit for a pollutant that is based on the capability of a treatment method to reduce the pollutant to a certain concentration.

Toxic Pollutant

Pollutants or combinations of pollutants, including disease-causing agents, which after discharge and upon exposure, ingestion, inhalation, or assimilation into any organism, either directly from the environment or indirectly by ingestion through food chains, will, on the basis of information available to the Administrator of USEPA, cause death, disease, behavioral abnormalities, cancer, genetic mutations, physiological malfunctions, (including malfunctions in reproduction), or physical deformations, in such organisms or their offspring. Toxic pollutants also include those pollutants listed by the Administrator under CWA section 307(a)(1) and 40 CFR §401.15 or any pollutant listed under section 405(d) which relates to sludge management.

Toxicity Identification Evaluation (TIE)

A TIE is a set of procedures that seek to identify the specific chemical(s) responsible for toxicity. These procedures are generally performed in three phases (characterization, identification, and confirmation using aquatic organism toxicity tests).

Toxicity Reduction Evaluation (TRE)

A study conducted in a step-wise process designed to identify the causative agents of effluent or ambient toxicity, isolate the sources of toxicity, evaluate the effectiveness of toxicity control options, and then confirm the reduction in toxicity. The first steps of the TRE consist of the collection of data relevant to the toxicity, including additional toxicity testing, and an evaluation of facility operations and maintenance practices, and best management practices. A TIE may be required as part of the TRE, if appropriate.

Treatment Plant Capacity

For purposes of this Order, an average dry weather monthly effluent flow (May to October) of 2.7 MGD, and an average wet weather monthly effluent flow (November to April) of 3.6 mgd.

Untreated or Partially Treated Wastewater

Any volume of waste discharged from the sanitary sewer system upstream of a wastewater treatment plant headworks.

Waste

As used in the Ocean Plan, waste includes a Discharger's total discharge, of whatever origin (i.e., gross, not net, discharge).

Water Quality Control Plan

consists of a designation or establishment for the waters within a specified area of all of the following:

1. Beneficial uses to be protected.
2. Water quality objectives.
3. A program of implementation needed for achieving water quality objectives.

Water Quality Objectives means the limits or levels of water quality constituents or characteristics which are established for the reasonable protection of beneficial uses of water or the prevention of nuisance within a specific area.

Water Reclamation

The treatment of wastewater to render it suitable for reuse, the transportation of treated wastewater to the place of use, and the actual use of treated wastewater for a direct beneficial use or controlled use that would not otherwise occur.

Whole Effluent Toxicity (WET)

The total toxic effect of an effluent measured directly with a toxicity test.

Attachment B – Map

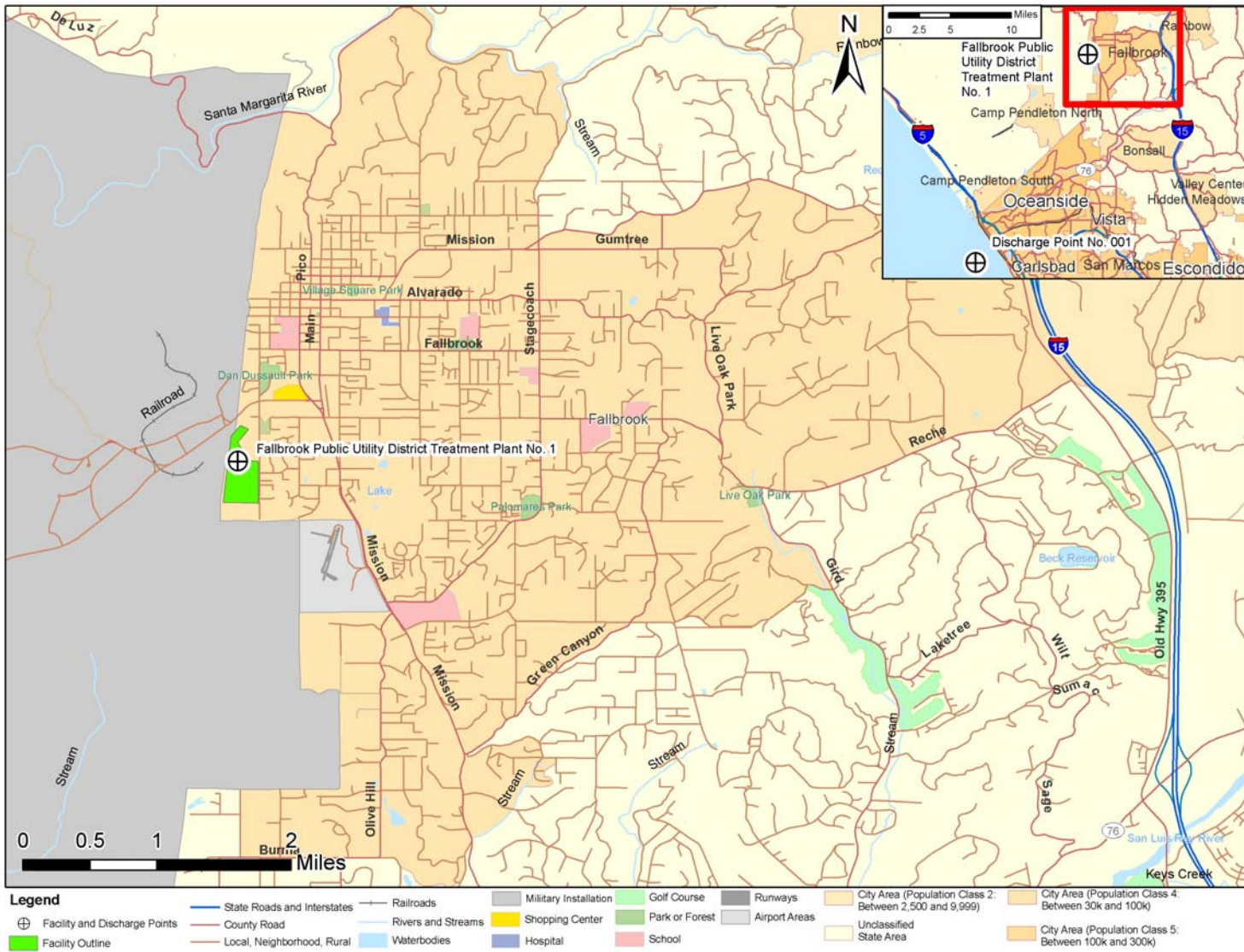

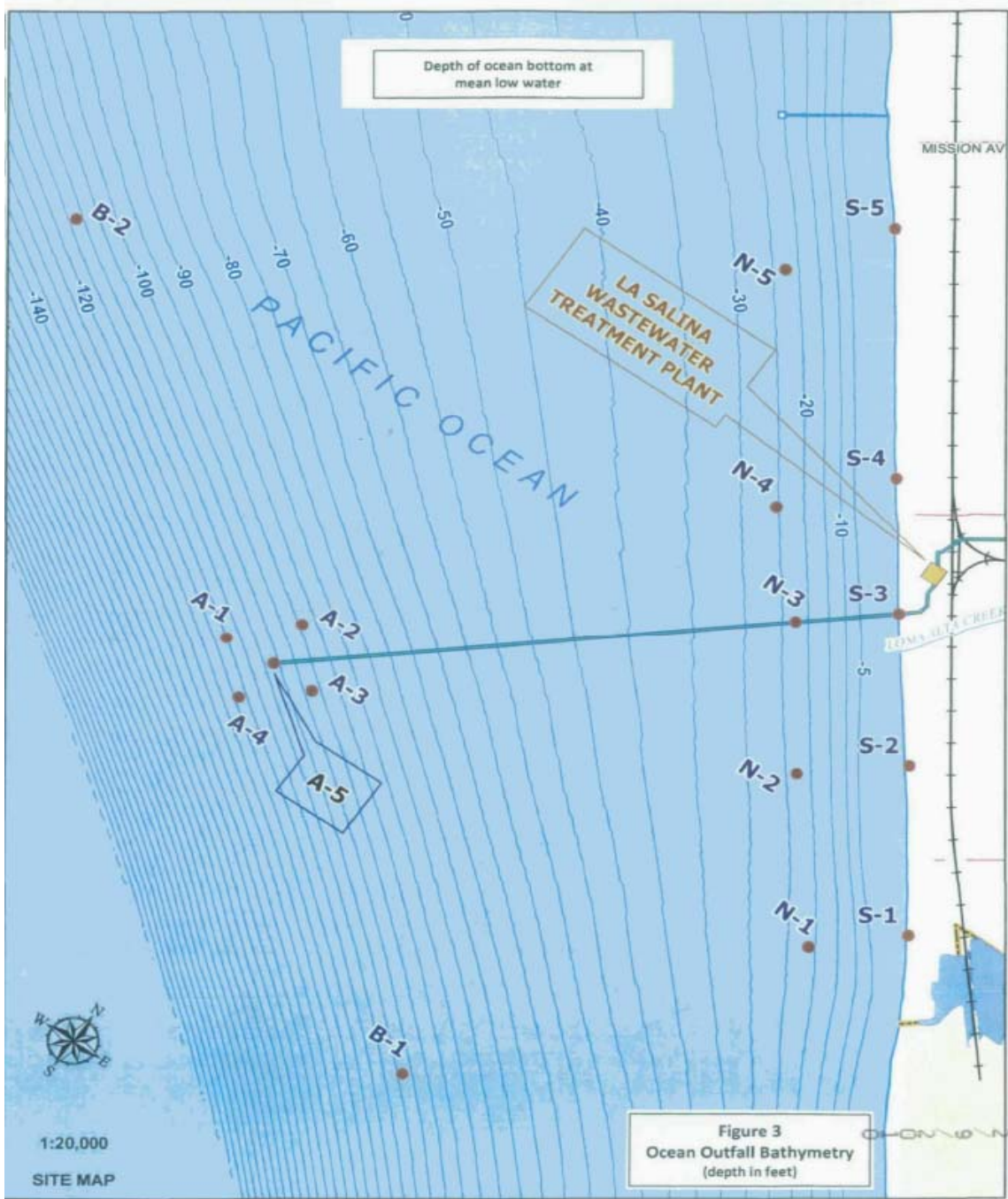

Attachment C – Flow Schematic

FALLBROOK PUBLIC UTILITY DISTRICT WASTEWATER TREATMENT PLANT NO. 1

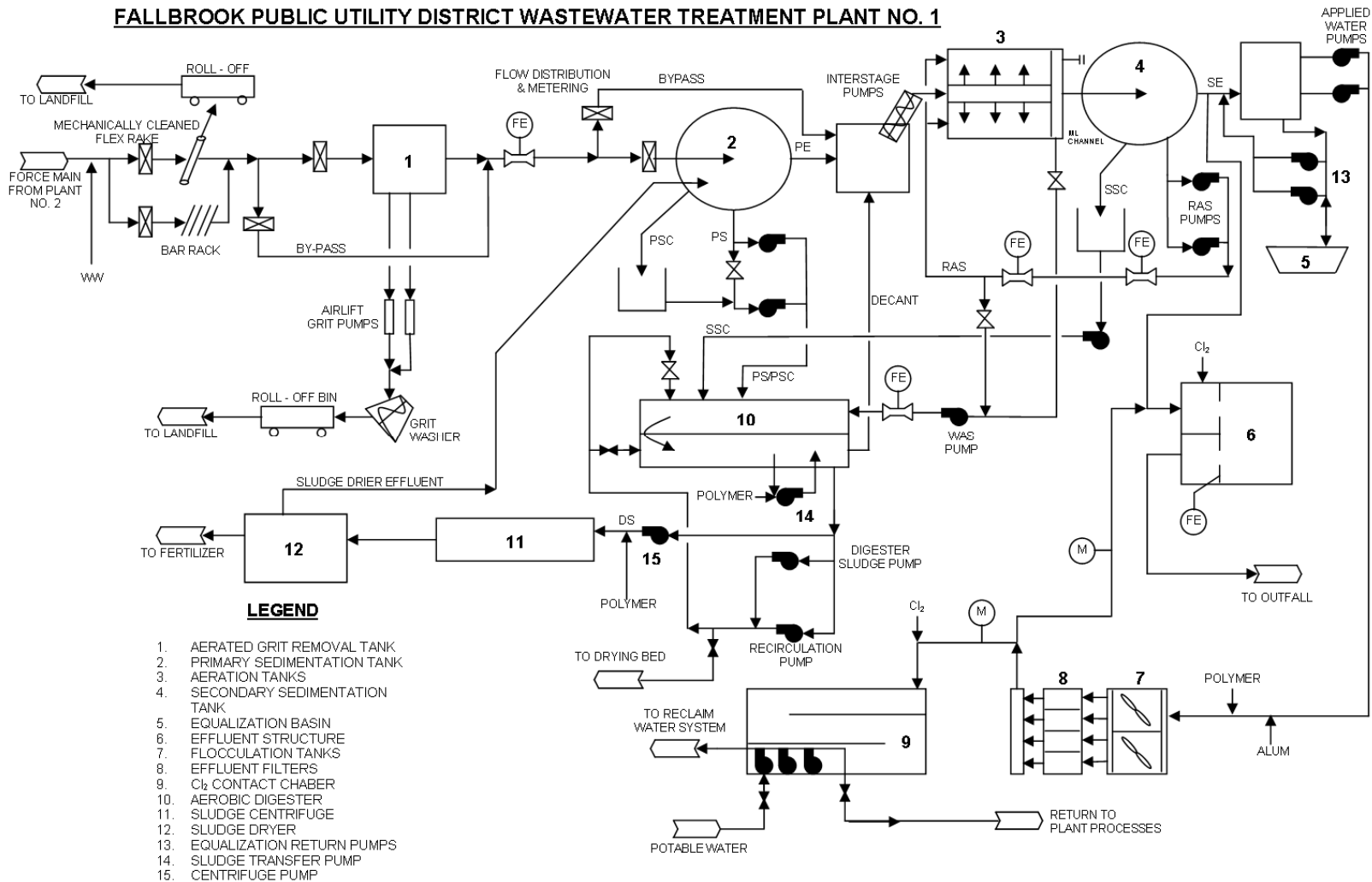

ATTACHMENT D – STANDARD PROVISIONS

I. STANDARD PROVISIONS – PERMIT COMPLIANCE

A. Duty to Comply

1. The Discharger must comply with all of the conditions of this Order. Any noncompliance constitutes a violation of the Clean Water Act (CWA) and the California Water Code (CWC) and is grounds for enforcement action; for permit termination, revocation and reissuance, or modification; or denial of a permit renewal application. (40 CFR 122.41(a))
2. The Discharger shall comply with effluent standards or prohibitions established under section 307(a) of the CWA for toxic pollutants and with standards for sewage sludge use or disposal established under section 405(d) of the CWA within the time provided in the regulations that establish these standards or prohibitions, even if this Order has not yet been modified to incorporate the requirement. (40 CFR 122.41(a)(1))

B. Need to Halt or Reduce Activity Not a Defense

It shall not be a defense for a Discharger in an enforcement action that it would have been necessary to halt or reduce the permitted activity in order to maintain compliance with the conditions of this Order. (40 CFR 122.41(c))

C. Duty to Mitigate

The Discharger shall take all reasonable steps to minimize or prevent any discharge or sludge use or disposal in violation of this Order that has a reasonable likelihood of adversely affecting human health or the environment. (40 CFR 122.41(d))

D. Proper Operation and Maintenance

The Discharger shall at all times properly operate and maintain all facilities and systems of treatment and control (and related appurtenances) which are installed or used by the Discharger to achieve compliance with the conditions of this Order. Proper operation and maintenance also includes adequate laboratory controls and appropriate quality assurance procedures. This provision requires the operation of backup or auxiliary facilities or similar systems that are installed by a Discharger only when necessary to achieve compliance with the conditions of this Order. (40 CFR 122.41(e))

E. Property Rights

1. This Order does not convey any property rights of any sort or any exclusive privileges. (40 CFR 122.41(g))
2. The issuance of this Order does not authorize any injury to persons or property or invasion of other private rights, or any infringement of State or local law or regulations. (40 CFR 122.5(c))

F. Inspection and Entry

The Discharger shall allow the San Diego Water Board, State Water Board, U.S. Environmental Protection Agency (USEPA), and/or their authorized representatives (including an authorized contractor acting as their representative), upon the presentation of credentials and other documents, as may be required by law, to (40 CFR 122.41(i); CWC, § 13383):

1. Enter upon the Discharger's premises where a regulated facility or activity is located or conducted, or where records are kept under the conditions of this Order (40 CFR 122.41(i)(1));
2. Have access to and copy, at reasonable times, any records that must be kept under the conditions of this Order (40 CFR 122.41(i)(2));
3. Inspect and photograph, at reasonable times, any facilities, equipment (including monitoring and control equipment), practices, or operations regulated or required under this Order (40 CFR 122.41(i)(3)); and
4. Sample or monitor, at reasonable times, for the purposes of assuring Order compliance or as otherwise authorized by the CWA or the CWC, any substances or parameters at any location. (40 CFR 122.41(i)(4))

G. Bypass

1. Definitions
 - a. "Bypass" means the intentional diversion of waste streams from any portion of a treatment facility. (40 CFR 122.41(m)(1)(i))
 - b. "Severe property damage" means substantial physical damage to property, damage to the treatment facilities, which causes them to become inoperable, or substantial and permanent loss of natural resources that can reasonably be expected to occur in the absence of a bypass. Severe property damage does not mean economic loss caused by delays in production. (40 CFR 122.41(m)(1)(ii))
2. Bypass not exceeding limitations. The Discharger may allow any bypass to occur which does not cause exceedances of effluent limitations, but only if it is for essential maintenance to assure efficient operation. These bypasses are not subject to the provisions listed in Standard Provisions – Permit Compliance I.G.3, I.G.4, and I.G.5 below. (40 CFR 122.41(m)(2))
3. Prohibition of bypass. Bypass is prohibited, and the San Diego Water Board may take enforcement action against a Discharger for bypass, unless (40 CFR 122.41(m)(4)(i)):
 - a. Bypass was unavoidable to prevent loss of life, personal injury, or severe property damage (40 CFR 122.41(m)(4)(i)(A));
 - b. There were no feasible alternatives to the bypass, such as the use of auxiliary treatment facilities, retention of untreated wastes, or maintenance during normal periods of equipment downtime. This condition is not satisfied if adequate back-up equipment

should have been installed in the exercise of reasonable engineering judgment to prevent a bypass that occurred during normal periods of equipment downtime or preventive maintenance (40 CFR 122.41(m)(4)(i)(B)); and

- c. The Discharger submitted notice to the San Diego Water Board as required under Standard Provisions – Permit Compliance I.G.5 below. (40 CFR 122.41(m)(4)(i)(C))
4. The San Diego Water Board may approve an anticipated bypass, after considering its adverse effects, if the San Diego Water Board determines that it will meet the three conditions listed in Standard Provisions – Permit Compliance I.G.3 above. (40 CFR 122.41(m)(4)(ii))
5. Notice
 - a. Anticipated bypass. If the Discharger knows in advance of the need for a bypass, it shall submit a notice, if possible at least 10 days before the date of the bypass. (40 CFR 122.41(m)(3)(i))
 - b. Unanticipated bypass. The Discharger shall submit notice of an unanticipated bypass as required in Standard Provisions - Reporting V.E below (24-hour notice). (40 CFR 122.41(m)(3)(ii))

H. Upset

Upset means an exceptional incident in which there is unintentional and temporary noncompliance with technology based permit effluent limitations because of factors beyond the reasonable control of the Discharger. An upset does not include noncompliance to the extent caused by operational error, improperly designed treatment facilities, inadequate treatment facilities, lack of preventive maintenance, or careless or improper operation. (40 CFR 122.41(n)(1))

1. Effect of an upset. An upset constitutes an affirmative defense to an action brought for noncompliance with such technology based permit effluent limitations if the requirements of Standard Provisions – Permit Compliance I.H.2 below are met. No determination made during administrative review of claims that noncompliance was caused by upset, and before an action for noncompliance, is final administrative action subject to judicial review. (40 CFR 122.41(n)(2))
2. Conditions necessary for a demonstration of upset. A Discharger who wishes to establish the affirmative defense of upset shall demonstrate, through properly signed, contemporaneous operating logs or other relevant evidence that (40 CFR 122.41(n)(3)):
 - a. An upset occurred and that the Discharger can identify the cause(s) of the upset (40 CFR 122.41(n)(3)(i));
 - b. The permitted facility was, at the time, being properly operated (40 CFR 122.41(n)(3)(ii));
 - c. The Discharger submitted notice of the upset as required in Standard Provisions – Reporting V.E.2.b below (24-hour notice) (40 CFR 122.41(n)(3)(iii)); and

- d. The Discharger complied with any remedial measures required under Standard Provisions – Permit Compliance I.C above. (40 CFR 122.41(n)(3)(iv))
3. Burden of proof. In any enforcement proceeding, the Discharger seeking to establish the occurrence of an upset has the burden of proof. (40 CFR 122.41(n)(4))

II. STANDARD PROVISIONS – PERMIT ACTION

A. General

This Order may be modified, revoked and reissued, or terminated for cause. The filing of a request by the Discharger for modification, revocation and reissuance, or termination, or a notification of planned changes or anticipated noncompliance does not stay any Order condition. (40 CFR 122.41(f))

B. Duty to Reapply

If the Discharger wishes to continue an activity regulated by this Order after the expiration date of this Order, the Discharger must apply for and obtain a new permit. (40 CFR 122.41(b))

C. Transfers

This Order is not transferable to any person except after notice to the San Diego Water Board. The San Diego Water Board may require modification or revocation and reissuance of the Order to change the name of the Discharger and incorporate such other requirements as may be necessary under the CWA and the CWC. (40 CFR 122.41(l)(3); 122.61)

III. STANDARD PROVISIONS – MONITORING

- A. Samples and measurements taken for the purpose of monitoring shall be representative of the monitored activity. (40 CFR 122.41(j)(1))
- B. Monitoring results must be conducted according to test procedures under 40 CFR Part 136 or, in the case of sludge use or disposal, approved under 40 CFR Part 136 unless otherwise specified in 40 CFR Part 503 unless other test procedures have been specified in this Order. (40 CFR 122.41(j)(4); 122.44(i)(1)(iv))

IV. STANDARD PROVISIONS – RECORDS

- A. Except for records of monitoring information required by this Order related to the Discharger's sewage sludge use and disposal activities, which shall be retained for a period of at least five years (or longer as required by 40 CFR Part 503), the Discharger shall retain records of all monitoring information, including all calibration and maintenance records and all original strip chart recordings for continuous monitoring instrumentation, copies of all reports required by this Order, and records of all data used to complete the application for this Order, for a period of at least three (3) years from the date of the sample, measurement, report or application. This period may be extended by request of the San Diego Water Board at any time. (40 CFR 122.41(j)(2))

B. Records of monitoring information shall include:

1. The date, exact place, and time of sampling or measurements (40 CFR 122.41(j)(3)(i));
2. The individual(s) who performed the sampling or measurements (40 CFR 122.41(j)(3)(ii));
3. The date(s) analyses were performed (40 CFR 122.41(j)(3)(iii));
4. The individual(s) who performed the analyses (40 CFR 122.41(j)(3)(iv));
5. The analytical techniques or methods used (40 CFR 122.41(j)(3)(v)); and
6. The results of such analyses. (40 CFR 122.41(j)(3)(vi))

C. Claims of confidentiality for the following information will be denied (40 CFR 122.7(b)):

1. The name and address of any permit applicant or Discharger (40 CFR 122.7(b)(1)); and
2. Permit applications and attachments, permits and effluent data. (40 CFR 122.7(b)(2))

V. STANDARD PROVISIONS – REPORTING

A. Duty to Provide Information

The Discharger shall furnish to the San Diego Water Board, State Water Board, or USEPA within a reasonable time, any information which the San Diego Water Board, State Water Board, or USEPA may request to determine whether cause exists for modifying, revoking and reissuing, or terminating this Order or to determine compliance with this Order. Upon request, the Discharger shall also furnish to the San Diego Water Board, State Water Board, or USEPA copies of records required to be kept by this Order. (40 CFR 122.41(h); CWC, § 13267)

B. Signatory and Certification Requirements

1. All applications, reports, or information submitted to the San Diego Water Board, State Water Board, and/or USEPA shall be signed and certified in accordance with Standard Provisions – Reporting V.B.2, V.B.3, V.B.4, and V.B.5 below. (40 CFR 122.41(k))
2. All permit applications shall be signed by either a principal executive officer or ranking elected official. For purposes of this provision, a principal executive officer of a federal agency includes: (i) the chief executive officer of the agency, or (ii) a senior executive officer having responsibility for the overall operations of a principal geographic unit of the agency (e.g., Regional Administrators of USEPA). (40 CFR 122.22(a)(3)).
3. All reports required by this Order and other information requested by the San Diego Water Board, State Water Board, or USEPA shall be signed by a person described in Standard Provisions – Reporting V.B.2 above, or by a duly authorized representative of that person. A person is a duly authorized representative only if:

- a. The authorization is made in writing by a person described in Standard Provisions – Reporting V.B.2 above (40 CFR 122.22(b)(1));
 - b. The authorization specifies either an individual or a position having responsibility for the overall operation of the regulated facility or activity such as the position of plant manager, operator of a well or a well field, superintendent, position of equivalent responsibility, or an individual or position having overall responsibility for environmental matters for the company. (A duly authorized representative may thus be either a named individual or any individual occupying a named position.) (40 CFR 122.22(b)(2)); and
 - c. The written authorization is submitted to the San Diego Water Board and State Water Board. (40 CFR 122.22(b)(3))
4. If an authorization under Standard Provisions – Reporting V.B.3 above is no longer accurate because a different individual or position has responsibility for the overall operation of the facility, a new authorization satisfying the requirements of Standard Provisions – Reporting V.B.3 above must be submitted to the San Diego Water Board and State Water Board prior to or together with any reports, information, or applications, to be signed by an authorized representative. (40 CFR 122.22(c))
 5. Any person signing a document under Standard Provisions – Reporting V.B.2 or V.B.3 above shall make the following certification¹:

“I certify under penalty of law that this document and all attachments were prepared under my direction or supervision in accordance with a system designed to assure that qualified personnel properly gather and evaluate the information submitted. Based on my inquiry of the person or persons who manage the system or those persons directly responsible for gathering the information, the information submitted is, to the best of my knowledge and belief, true, accurate, and complete. I am aware that there are significant penalties for submitting false information, including the possibility of fine and imprisonment for knowing violations.” (40 CFR 122.22(d))

C. Monitoring Reports

1. Monitoring results shall be reported at the intervals specified in the Monitoring and Reporting Program (Attachment E of this Order). (40 CFR 122.41(l)(4))
2. Monitoring results must be reported on a Discharge Monitoring Report (DMR) form or forms provided or specified by the San Diego Water Board or State Water Board for reporting results of monitoring of sludge use or disposal practices. (40 CFR 122.41(l)(4)(i))

¹ On March 3, 2000, USEPA issued a memorandum stating that a certification of “accuracy” in information submissions is a certification that the information provided is “accurate” as the layperson uses the term, rather than “accurate” as that term is used to describe the quantifiable performance of a measurement system. In USEPA documents associated with testing procedures for measuring whole effluent toxicity, the Agency stated that the “accuracy” of toxicity tests cannot be determined in a meaningful way. When a person certifies that the submission of WET testing information is “accurate” to the best of their knowledge and belief, the person certifies that the results obtained using the WET testing procedures are faithfully and truthfully transcribed on the information submission, and that the results were, in fact, results that were obtained using the specified testing procedures.

3. If the Discharger monitors any pollutant more frequently than required by this Order using test procedures approved under 40 CFR Part 136 or, in the case of sludge use or disposal, approved under 40 CFR Part 136 unless otherwise specified in 40 CFR Part 503, or as specified in this Order, the results of this monitoring shall be included in the calculation and reporting of the data submitted in the DMR or sludge reporting form specified by the San Diego Water Board. (40 CFR 122.41(l)(4)(ii))
4. Calculations for all limitations, which require averaging of measurements, shall utilize an arithmetic mean unless otherwise specified in this Order. (40 CFR 122.41(l)(4)(iii))

D. Compliance Schedules

Reports of compliance or noncompliance with, or any progress reports on, interim and final requirements contained in any compliance schedule of this Order, shall be submitted no later than 14 days following each schedule date. (40 CFR 122.41(l)(5))

E. Twenty Four-Hour Reporting

1. The Discharger shall report any noncompliance that may endanger health or the environment. Any information shall be provided orally within 24 hours from the time the Discharger becomes aware of the circumstances. A written submission shall also be provided within five (5) days of the time the Discharger becomes aware of the circumstances. The written submission shall contain a description of the noncompliance and its cause; the period of noncompliance, including exact dates and times, and if the noncompliance has not been corrected, the anticipated time it is expected to continue; and steps taken or planned to reduce, eliminate, and prevent reoccurrence of the noncompliance. (40 CFR 122.41(l)(6)(i))
2. The following shall be included as information that must be reported within 24 hours under this paragraph (40 CFR 122.41(l)(6)(ii)):
 - a. Any unanticipated bypass that exceeds any effluent limitation in this Order. (40 CFR 122.41(l)(6)(ii)(A))
 - b. Any upset that exceeds any effluent limitation in this Order. (40 CFR 122.41(l)(6)(ii)(B))
3. The San Diego Water Board may waive the above-required written report under this provision on a case-by-case basis if an oral report has been received within 24 hours. (40 CFR 122.41(l)(6)(iii))

F. Planned Changes

The Discharger shall give notice to the San Diego Water Board as soon as possible of any planned physical alterations or additions to the permitted facility. Notice is required under this provision only when (40 CFR 122.41(l)(1)):

1. The alteration or addition to a permitted facility may meet one of the criteria for determining whether a facility is a new source in 40 CFR 122.29(b) (40 CFR 122.41(l)(1)(i)); or

2. The alteration or addition could significantly change the nature or increase the quantity of pollutants discharged. This notification applies to pollutants that are not subject to effluent limitations in this Order. (40 CFR 122.41(l)(1)(ii))
3. The alteration or addition results in a significant change in the Discharger's sludge use or disposal practices, and such alteration, addition, or change may justify the application of permit conditions that are different from or absent in the existing permit, including notification of additional use or disposal sites not reported during the permit application process or not reported pursuant to an approved land application plan. (40 CFR 122.41(l)(1)(iii))

G. Anticipated Noncompliance

The Discharger shall give advance notice to the San Diego Water Board or State Water Board of any planned changes in the permitted facility or activity that may result in noncompliance with General Order requirements. (40 CFR 122.41(l)(2))

H. Other Noncompliance

The Discharger shall report all instances of noncompliance not reported under Standard Provisions – Reporting V.C, V.D, and V.E above at the time monitoring reports are submitted. The reports shall contain the information listed in Standard Provision – Reporting V.E above. (40 CFR 122.41(l)(7))

I. Other Information

When the Discharger becomes aware that it failed to submit any relevant facts in a permit application, or submitted incorrect information in a permit application or in any report to the San Diego Water Board, State Water Board, or USEPA, the Discharger shall promptly submit such facts or information. (40 CFR 122.41(l)(8))

VI. STANDARD PROVISIONS – ENFORCEMENT

- A. The San Diego Water Board is authorized to enforce the terms of this permit under several provisions of the CWC, including, but not limited to, sections 13385, 13386, and 13387.

VII. ADDITIONAL PROVISIONS – NOTIFICATION LEVELS

A. Publicly-Owned Treatment Works (POTWs)

All POTWs shall provide adequate notice to the San Diego Water Board of the following (40 CFR 122.42(b)):

1. Any new introduction of pollutants into the POTW from an indirect discharger that would be subject to sections 301 or 306 of the CWA if it were directly discharging those pollutants (40 CFR 122.42(b)(1)); and

- 2.** Any substantial change in the volume or character of pollutants being introduced into that POTW by a source introducing pollutants into the POTW at the time of adoption of the Order. (40 CFR 122.42(b)(2))
- 3.** Adequate notice shall include information on the quality and quantity of effluent introduced into the POTW as well as any anticipated impact of the change on the quantity or quality of effluent to be discharged from the POTW. (40 CFR 122.42(b)(3)).

ATTACHMENT E – MONITORING AND REPORTING PROGRAM

Table of Contents

I. General Monitoring Provisions..... E-2

II. Monitoring Locations E-3

III. Influent Monitoring Requirements..... E-4

 A. Monitoring Location M-INF..... E-4

IV. Effluent Monitoring Requirements E-4

 A. Monitoring Location M-001 E-4

V. Whole Effluent Toxicity Testing Requirements E-8

VI. Land Discharge Monitoring Requirements – Not Applicable E-10

VII. Reclamation Monitoring Requirements – Not Applicable..... E-10

VIII. Receiving Water Monitoring Requirements – Surface Water..... E-10

 A. Surf Zone Water Quality Monitoring E-10

 B. Near Shore Water Quality Monitoring E-11

 C. Off Shore Water Quality Monitoring E-12

 D. Benthic Monitoring E-13

 E. Additional Biological Monitoring – Demersal Fish and Macroinvertebrates..... E-13

IX. Other Monitoring Requirements..... E-14

 A. Kelp Bed Canopy E-14

 B. Regional Monitoring E-15

 C. Solids Monitoring E-15

X. Reporting Requirements..... E-15

 A. General Monitoring and Reporting Requirements..... E-15

 B. Self Monitoring Reports (SMRs) E-16

 C. Discharge Monitoring Reports (DMRs) E-19

 D. Other Reports E-19

List of Tables

Table E-1. Monitoring Station Locations..... E-3

Table E-2. Influent Monitoring at M-INF..... E-4

Table E-3. Effluent Monitoring at M-001 E-4

Table E-4. Effluent Monitoring at M-001 or M-002..... E-5

Table E-5. Whole Effluent Toxicity Testing E-8

Table E-6. Approved Test for Chronic Toxicity E-9

Table E-7. Near Shore Water Quality Reduced Monitoring Requirements E-11

Table E-8. Near Shore Water Quality Intensive Monitoring Requirements E-11

Table E-9. Off Shore Water Quality Reduced Monitoring Requirements..... E-12

Table E-10. Off Shore Water Quality Intensive Monitoring Requirements E-12

Table E-11. Sediment Monitoring Requirements E-13

Table E-12. Infauna Monitoring Requirements E-13

Table E-13. Demersal Fish and Macroinvertebrates Monitoring Requirements..... E-14

Table E-14. Monitoring Periods and Reporting Schedule..... E-16

ATTACHMENT E – MONITORING AND REPORTING PROGRAM (MRP)

The Code of Federal Regulations (40 CFR §122.48) require that all National Pollutant Discharge Elimination System (NPDES) permits specify monitoring and reporting requirements. California Water Code (CWC) sections 13267 and 13383 also authorize the California Regional Water Quality Control Board, San Diego Region (San Diego Water Board) to require technical and monitoring reports. This MRP establishes monitoring and reporting requirements, which implement the federal and State regulations.

I. GENERAL MONITORING PROVISIONS

- A.** Samples and measurements taken as required herein shall be representative of the volume and nature of the monitoring discharge. All samples shall be taken at the monitoring locations specified below and, unless otherwise specified, before the monitored flow joins or is diluted by any other waste stream, body of water, or substance. Monitoring locations shall not be changed without notification to and the approval of the San Diego Water Board. Samples shall be collected at times representative of “worst case” conditions with respect to compliance with the requirement of this Order.
- B.** Appropriate flow measurement devices and methods consistent with accepted scientific practices shall be selected and used to ensure the accuracy and reliability of measurements of the volume of monitored discharges. The devices shall be installed, calibrated and maintained to ensure that the accuracy of the measurement is consistent with the accepted capability of that type of device. Devices selected shall be capable of measuring flows with a maximum deviation of less than ± 5 percent from true discharge rates throughout the range of expected discharge volumes.
- C.** Monitoring must be conducted according to U.S. Environmental Protection Agency (USEPA) test procedures approved at 40 CFR Part 136, *Guidelines Establishing Test Procedures for the Analysis of Pollutants Under the Clean Water Act* as amended, or unless other test procedures are specified in this Order and/or in this MRP and/or by the San Diego Water Board.
- D.** All analyses shall be performed in a laboratory certified to perform such analyses by the California Department of Public Health (DPH) or a laboratory approved by the San Diego Water Board.
- E.** Records of monitoring information shall include information required under Standard Provision, Attachment D of this Order, section IV.
- F.** All monitoring instruments and devices used by FPUD to fulfill the prescribed monitoring program shall be properly maintained and calibrated as necessary to ensure their continued accuracy. All flow measurement devices shall be calibrated at least once per year, or more frequently, to ensure continued accuracy of the devices.
- G.** FPUD shall have, and implement, an acceptable written quality assurance (QA) plan for laboratory analyses. Duplicate chemical analyses must be conducted on a minimum of 10 percent of the samples or at least one sample per month, whichever is greater. A similar frequency shall be maintained for analyzing spiked samples. When requested by USEPA or the San Diego Water Board, FPUD will participate in the NPDES discharge monitoring report QA performance study. FPUD should have a success rate equal or greater than 80 percent.

- H. Analysis for toxic pollutants, including chronic toxicity, with performance goals based on water quality objectives of the 2005 California Ocean Plan (hereinafter Ocean Plan) shall be conducted in accordance with procedures described in the Ocean Plan and restated in this MRP.
- I. This permit may be modified in accordance with the requirements set forth at 40 CFR Parts 122 and 124, to include appropriate conditions or limits to address demonstrated effluent toxicity based on newly available information, or to implement any USEPA approved, new, State water quality standards applicable to effluent toxicity.

II. MONITORING LOCATIONS

FPUD shall establish the following monitoring locations to demonstrate compliance with the effluent limitations, discharge specifications, and other requirements in this Order:

Table E-1. Monitoring Station Locations

Discharge Point Name	Monitoring Location Name	Monitoring Location Description
--	M-INF	At a location where all influent flows to Treatment Plant No. 1 are accounted for in monitoring events; upstream of any in-plant return flows; and where representative samples of influent can be collected.
--	M-001	Downstream of any in-plant return flows and chlorine disinfection where representative samples of effluent treated solely at Treatment Plant No. 1 can be collected.
001	M-002	At a location other than M-001 where representative samples of effluent from Treatment Plant No. 1 can be collected before combining with wastewater from the City of Oceanside, US Marine Corps Base Camp Pendleton, and Genetech, Inc. Current location is near terminus of the Fallbrook Land Outfall and prior to connecting to the Oceanside Ocean Outfall
SURF ZONE STATIONS		
--	S1	Surf zone, 5,500 feet south of the outfall.
--	S2	Surf zone, 2,500 feet south of the outfall.
--	S3	Surf zone; at the outfall
--	S4	Surf zone, 2,000 feet north of the outfall.
--	S5	Surf zone, 5,800 feet north of the outfall.
NEAR SHORE STATIONS		
--	N1	Opposite S1, at the 30 foot depth contour, MLLW.
--	N2	Opposite S2, at the 30 foot depth contour, MLLW.
--	N3	Opposite S3, at the 30 foot depth contour, MLLW.
--	N4	Opposite S4, at the 30 foot depth contour, MLLW.
--	N5	Opposite S5, at the 30 foot depth contour, MLLW.
OFFSHORE STATIONS		
--	A1-A4	At the corners of a 1,000 ft x 1,000 ft square having one side parallel to shore and the intersection of its diagonals at the seaward end of the outfall.
--	A5	At the seaward end of the outfall.
--	B1	One mile downcoast from the outfall, and over the same depth contour as Station A5.
--	B2	One mile upcoast from the outfall and over the same depth contour as Station A5.

Discharge Point Name	Monitoring Location Name	Monitoring Location Description
BIOLOGICAL TRANSECTS		
--	T0	At the 20, 40, 60, and 80 foot depth contours along the transect located 50 feet downcoast of and parallel to the outfall.
--	T1	At the 20, 40, 60, and 80 foot depth contours along the transect located 1 mile downcoast of and parallel to the outfall.
--	T2	At the 20, 40, 60, and 80 foot depth contours along the transect located 1.5 miles downcoast of and parallel to the outfall.

III. INFLUENT MONITORING REQUIREMENTS

A. Monitoring Location M-INF

1. FPUD shall monitor the influent at M-INF, as follows.

Table E-2. Influent Monitoring at M-INF

Parameter	Units	Sample Type	Minimum Sampling Frequency	Required Analytical Test Method
Flow	MGD	Recorder/Totalizer	Continuous	--
Carbonaceous Biochemical Oxygen Demand (5-day @ 20°C) (CBOD ₅)	mg/L	24-hr Composite	1/Week	1
Total Suspended Solids (TSS)	mg/L	24-hr Composite	1/Week	1

¹ As required under 40 CFR Part 136.

IV. EFFLUENT MONITORING REQUIREMENTS

A. Monitoring Location M-001

1. FPUD shall monitor the effluent at M-001 as follows.

Table E-3. Effluent Monitoring at M-001

Parameter	Units	Sample Type	Minimum Sampling Frequency	Required Analytical Test Method
TSS	mg/L	24-hr Composite	1/Day ²	1,3,4
CBOD ₅	mg/L	24-hr composite	1/Day ²	1,3,4
Oil and Grease	mg/L	Grab	1/Month ⁵	1,3
Settleable Solids	mL/L	Grab	1/Day ²	1
Turbidity	NTU	24hr Composite	1/Week ⁵	1
pH	pH Units	Grab	1/Day ²	1

¹ As required under 40 CFR Part 136.

- ² Applies 5 days per week, except 7 days per week for at least 1 week in July or August of each year.
- ³ FPUD shall calculate and report the mass emission rate (MER) of the constituent for each sample taken. The MER shall be calculated in accordance with section VII.I.2.d of this Order.
- ⁴ FPUD shall calculate the monthly average percent removal for these constituents.
- ⁵ The minimum frequency of monitoring for this constituent is automatically increased to twice the minimum frequency specified, if any analysis for this constituent yields a result higher than the applicable effluent limitation or performance goal specified in this Order. The increased minimum frequency of monitoring shall remain in effect until the results of a minimum of four consecutive analyses for this constituent are below all applicable effluent limitations or performance goals specified in this Order.

2. FPUD shall monitor the effluent from M-001 or M-002 (Discharge Point No. 001) as follows.

Table E-4. Effluent Monitoring at M-001 or M-002

Parameter	Units	Sample Type	Minimum Sampling Frequency	Required Analytical Test Method
Temperature	°F	Grab	1/Week	1
Dissolved Oxygen	mg/L	Grab	1/Week	1
Flow	MGD	Recorder/Totalizer	Continuous	--
TABLE B PARAMETERS FOR PROTECTION OF MARINE AQUATIC LIFE				
Arsenic, Total Recoverable	µg/L	24-hr Composite	2/Year ^{2,3}	1
Cadmium, Total Recoverable	µg/L	24-hr Composite	2/Year ^{2,3}	1
Chromium (VI), Total Recoverable ⁴	µg/L	24-hr Composite	2/Year ^{2,3,4}	1
Copper, Total Recoverable	µg/L	24-hr Composite	2/Year ^{2,3}	1
Lead, Total Recoverable	µg/L	24-hr Composite	2/Year ^{2,3}	1
Mercury, Total Recoverable	µg/L	24-hr Composite	2/Year ^{2,3}	1
Nickel, Total Recoverable	µg/L	24-hr Composite	2/Year ^{2,3}	1
Selenium, Total Recoverable	µg/L	24-hr Composite	2/Year ^{2,3}	1
Silver, Total Recoverable	µg/L	24-hr Composite	2/Year ^{2,3}	1
Zinc, Total Recoverable	µg/L	24-hr Composite	2/Year ^{2,3}	1
Cyanide, Total Recoverable ⁵	µg/L	24-hr Composite	2/Year ^{2,3}	1,6
Chlorine, Total Residual	µg/L	Grab	1/Week ^{2,6}	1
Ammonia Nitrogen, Total (as N)	mg/L	24-hr Composite	1/Month ^{2,3}	1
Phenolic Compounds (nonchlorinated) ⁷	µg/L	24-hr Composite	2/Year ^{2,3}	1
Phenolic Compounds (chlorinated) ⁸	µg/L	24-hr Composite	2/Year ^{2,3}	1
Endosulfan ⁹	µg/L	24-hr Composite	2/Year ^{2,3}	1
Endrin	µg/L	24-hr Composite	2/Year ^{2,3}	1
HCH ¹⁰	µg/L	24-hr Composite	2/Year ^{2,3}	1
Radioactivity	pCi/L	24-hr Composite	2/Year ^{2,3}	1
TABLE B PARAMETERS FOR PROTECTION OF HUMAN HEALTH – NONCARCINOGENS				
Acrolein	µg/L	Grab	1/Year ^{2,3}	1
Antimony, Total Recoverable	µg/L	24-hr Composite	1/Year ^{2,3}	1
Bis (2-chloroethoxy) Methane	µg/L	Grab	1/Year ^{2,3}	1
Bis (2-chloroisopropyl) Ether	µg/L	Grab	1/Year ^{2,3}	1
Chlorobenzene	µg/L	Grab	1/Year ^{2,3}	1
Chromium (III), Total Recoverable	µg/L	24-hr Composite	1/Year ^{2,3}	1

Di-n-butyl Phthalate	µg/L	Grab	1/Year ^{2,3}	1
Dichlorobenzenes ¹¹	µg/L	Grab	1/Year ^{2,3}	1
Diethyl Phthalate	µg/L	Grab	1/Year ^{2,3}	1
Dimethyl Phthalate	µg/L	Grab	1/Year ^{2,3}	1
4,6-dinitro-2-methylphenol	µg/L	Grab	1/Year ^{2,3}	1
2,4-dinitrophenol	µg/L	Grab	1/Year ^{2,3}	1
Ethylbenzene	µg/L	Grab	1/Year ^{2,3}	1
Fluoranthene	µg/L	Grab	1/Year ^{2,3}	1
Hexachlorocyclopentadiene	µg/L	Grab	1/Year ^{2,3}	1
Nitrobenzene	µg/L	Grab	1/Year ^{2,3}	1
Thallium, Total Recoverable	µg/L	24-hr Composite	1/Year ^{2,3}	1
Toluene	µg/L	Grab	1/Year ^{2,3}	1
Tributyltin	µg/L	24-hr Composite	1/Year ^{2,3}	1
1,1,1-trichloroethane	µg/L	Grab	1/Year ^{2,3}	1
TABLE B PARAMETERS FOR PROTECTION OF HUMAN HEALTH – CARCINOGENS				
Acrylonitrile	µg/L	Grab	1/Year ^{2,3}	1
Aldrin	µg/L	Grab	1/Year ^{2,3}	1
Benzene	µg/L	Grab	1/Year ^{2,3}	1
Benzidine	µg/L	Grab	1/Year ^{2,3}	1
Beryllium, Total Recoverable	µg/L	24-hr composite	1/Year ^{2,3}	1
Bis (2-chloroethyl) Ether	µg/L	Grab	1/Year ^{2,3}	1
Bis (2-ethylhexyl) Phthalate	µg/L	Grab	1/Year ^{2,3}	1
Carbon Tetrachloride	µg/L	Grab	1/Year ^{2,3}	1
Chlordane	µg/L	Grab	1/Year ^{2,3}	1
Chlorodibromomethane	µg/L	Grab	1/Year ^{2,3}	1
Chloroform	µg/L	Grab	1/Year ^{2,3}	1
DDT ¹²	µg/L	Grab	1/Year ^{2,3}	1
1,4-dichlorobenzene	µg/L	Grab	1/Year ^{2,3}	1
3,3'-dichlorobenzidine	µg/L	Grab	1/Year ^{2,3}	1
1,2-dichloroethane	µg/L	Grab	1/Year ^{2,3}	1
1,1-dichloroethylene	µg/L	Grab	1/Year ^{2,3}	1
Dichlorobromomethane	µg/L	Grab	1/Year ^{2,3}	1
Dichloromethane	µg/L	Grab	1/Year ^{2,3}	1
1,3-dichloropropene	µg/L	Grab	1/Year ^{2,3}	1
Dieldrin	µg/L	Grab	1/Year ^{2,3}	1
2,4-dinitrotoluene	µg/L	Grab	1/Year ^{2,3}	1
1,2-diphenylhydrazine	µg/L	Grab	1/Year ^{2,3}	1
Halomethanes ¹³	µg/L	Grab	1/Year ^{2,3}	1
Heptachlor	µg/L	Grab	1/Year ^{2,3}	1
Heptachlor Epoxide	µg/L	Grab	1/Year ^{2,3}	1
Hexachlorobenzene	µg/L	Grab	1/Year ^{2,3}	1
Hexachlorobutadiene	µg/L	Grab	1/Year ^{2,3}	1
Hexachloroethane	µg/L	Grab	1/Year ^{2,3}	1
Isophorone	µg/L	Grab	1/Year ^{2,3}	1
N-nitrosodimethylamine	µg/L	Grab	1/Year ^{2,3}	1

N-nitrosodi-N-propylamine	µg/L	Grab	1/Year ^{2,3}	1
N-nitrosodiphenylamine	µg/L	Grab	1/Year ^{2,3}	1
PAHs ¹⁴	µg/L	Grab	1/Year ^{2,3}	1
PCBs ¹⁵	µg/L	Grab	1/Year ^{2,3}	1
TCDD equivalents ¹⁶	µg/L	Grab	2/Year ^{2,3}	1
1,1,2-tetrachloroethane	µg/L	Grab	1/Year ^{2,3}	1
Tetrachloroethylene	µg/L	Grab	1/Year ^{2,3}	1
Toxaphene	µg/L	Grab	1/Year ^{2,3}	1
Trichloroethylene	µg/L	Grab	1/Year ^{2,3}	1
1,1,2-trichloroethane	µg/L	Grab	1/Year ^{2,3}	1
2,4,6-trichlorophenol	µg/L	Grab	1/Year ^{2,3}	1
Vinyl Chloride	µg/L	Grab	1/Year ^{2,3}	1

¹ As required under 40 CFR Part 136.

² FPUD shall calculate and report the mass emission rate (MER) of the constituent for each sample taken. The MER shall be calculated in accordance with section VII.I.2.d of this Order.

³ The minimum frequency of monitoring for this constituent is automatically increased to twice the minimum frequency specified, if any analysis for this constituent yields a result higher than the applicable effluent limitation or performance goal specified in this Order. The increased minimum frequency of monitoring shall remain in effect until the results of a minimum of four consecutive analyses for this constituent are below all applicable effluent limitations or performance goals specified in this Order.

⁴ Dischargers may, at their option, apply this performance goal as a total chromium performance goal.

⁵ If a Discharger can demonstrate to the satisfaction of the San Diego Water Board (subject to USEPA approval) that an analytical method is available to reliably distinguish between strongly and weakly complexed cyanide, performance goals for cyanide may be met by the combined measurement of free cyanide, simple alkali metals cyanides, and weakly complexed organometallic cyanide complexes. In order for the analytical method to be acceptable, the recovery of free cyanide from metal complexes must be comparable to that achieved by the approved method in 40 CFR Part 136, as revised May 14, 1999.

⁶ Monitoring of total chlorine residual is not required on days when none of the treatment units that are subject to this Order use chlorine for disinfection. If only one sample is collected for total chlorine residual analysis on a particular day, that sample must be collected at the time when the concentration of total chlorine residual in the discharge would be expected to be greatest. The times of chlorine discharges on the days that samples are collected, and the time at which samples are collected, shall be reported.

⁷ Non-chlorinated phenolic compounds represent the sum of 2,4-dimethylphenol, 4,6-Dinitro-2-methylphenol, 2,4-dinitrophenol, 2-methylphenol, 4-methylphenol, 2-Nitrophenol, 4-nitrophenol, and phenol.

⁸ Chlorinated phenolic compounds represent the sum of 4-chloro-3-methylphenol, 2-chlorophenol, pentachlorophenol, 2,4,5-trichlorophenol, and 2,4,6-trichlorophenol.

⁹ Endosulfan represents the sum of alpha-endosulfan, beta-endosulfan, and endosulfan sulfate.

¹⁰ HCH (hexachlorocyclohexane) represents the sum of the alpha, beta, gamma (Lindane), and delta isomers of hexachlorocyclohexane.

¹¹ Dichlorobenzenes represent the sum of 1,2- and 1,3-dichlorobenzene.

¹² DDT represents the sum of 4,4' DDT; 2,4' DDT; 4,4' DDE; 2,4' DDE; 4,4' DDD; and 2,4' DDD.

¹³ Halomethanes represent the sum of bromoform, bromomethane (methyl bromide), and chloromethane (methyl chloride).

¹⁴ PAHs (polynuclear aromatic hydrocarbons) represent the sum of acenaphthalene; anthracene; 1,2-benzanthracene; 3,4-benzofluoranthene; benzo[k]fluoranthene; 1,12-benzoperylene; benzo[a]pyrene; chrysene; dibenzo[a,h]anthracene; fluorene; indeno[1,2,3-cd]pyrene; phenanthrene; and pyrene.

¹⁵ PCBs (polychlorinated biphenyls) represent the sum of chlorinated biphenyls whose analytical characteristics resemble those of Aroclor-1016, Aroclor-1221, Aroclor-1232, Aroclor-1242, Aroclor-1248, Aroclor-1254, and Aroclor-1260.

¹⁶ TCDD equivalents represent the sum of concentrations of chlorinated dibenzodioxins (2,3,7,8-CDDs) and chlorinated dibenzofurans (2,3,7,8-CDFs) multiplied by their respective toxicity factors, as shown by the table below. USEPA Method 8280 may be used to analyze TCDD equivalents.

Isomer Group	Toxicity Equivalence Factor
2,3,7,8 – tetra CDD	1.0
2,3,7,8 – penta CDD	0.5
2,3,7,8 – hexa CDD	0.1
2,3,7,8 – hepta CDD	0.01
octa CDD	0.001
2,3,7,8 – tetra CDF	0.1
1,2,3,7,8 – penta CDF	0.05
2,3,4,7,8 – penta CDF	0.5
2,3,7,8 – hexa CDFs	0.1
2,3,7,8 – hepta CDFs	0.01
Octa CDF	0.001

V. WHOLE EFFLUENT TOXICITY TESTING REQUIREMENTS

FPUD shall conduct chronic toxicity testing on effluent samples collected at Effluent Monitoring Station M-002 in accordance with the following schedule and requirements:

Table E-5. Whole Effluent Toxicity Testing

Test	Unit	Sample Type	Minimum Test Frequency
Screening period for chronic toxicity	TU _c	24-hr Composite	Every other year for 3 consecutive months, beginning with the calendar year 2011
Chronic Toxicity	TU _c	24-hr Composite	1/Quarter

Marine Organisms, 5th Edition, October 2002 (EPA-821-R-02-012).

Critical life stage toxicity tests shall be performed to measure chronic toxicity (TU_c). Testing shall be performed using methods outlined in *Short-Term Methods for Estimating the Chronic Toxicity of Effluent and Receiving Waters to West Coast Marine Estuarine Organisms* (Chapman, G.A., D.L. Denton, and J.M. Lazorchak, 1995) or *Procedures Manual for Conducting Toxicity Tests Developed by the Marine Bioassay Project* (State Water Board, 1996).

A screening period for chronic toxicity shall be conducted every other year beginning with the calendar year 2011. Each screening period shall consist of 3 consecutive months of WET tests, using a minimum of three test species with approved test protocols, from the following list (from the Ocean Plan). Repeat screening periods may be terminated after the first month if the most sensitive species is the same as the species previously found to be most sensitive. Other tests may be used, if they have been approved for such testing by the State Water Board. The test species shall include a fish, an invertebrate, and an aquatic plant. After the screening period, the most sensitive test species shall be used for the quarterly testing. Control and dilution water should be obtained from an unaffected area of the receiving water or should use lab water as appropriate. If the dilution water is different from the culture water, then culture water should be used in a second control. The sensitivity of the test organisms to a reference toxicant shall be determined concurrently with each bioassay test and reported with test results.

Table E-6. Approved Test for Chronic Toxicity

Species	Test	Tier ¹	Reference ²
giant kelp, <i>Macrocystis pyrifera</i>	percent germination; germ tube length	1	a, c
red abalone, <i>Haliotis rufescens</i>	abnormal shell development	1	a, c
oyster, <i>Crassostrea gigas</i> ; mussels, <i>Mytilus spp.</i>	abnormal shell development; percent survival	1	a, c
urchin, <i>Strongylocentrotus purpuratus</i> ; sand dollar, <i>Dendraster excentricus</i>	percent normal development	1	a, c
urchin, <i>Strongylocentrotus purpuratus</i> ; sand dollar, <i>Dendraster excentricus</i>	percent fertilization	1	a, c
shrimp, <i>Homesimysis costata</i>	percent survival; growth	1	a, c
shrimp, <i>Mysidopsis bahia</i>	percent survival; fecundity	2	b, d
topsmelt, <i>Atherinops affinis</i>	larval growth rate; percent survival	1	a, c
Silversides, <i>Menidia beryllina</i>	larval growth rate; percent survival	2	b, d

¹ First tier methods are preferred for compliance monitoring. If first tier organisms are not available, FPUD can use a second tier test method following approval by the San Diego Water Board.

² Protocol References:

- a. Chapman, G.A., D.L. Denton, and J.M. Lazorchak. 1995. Short-term Methods for Estimating the Chronic Toxicity of Effluents and Receiving Waters to West Coast Marine and Estuarine Organisms. USEPA Report No. EPA/600/R-95/136.
- b. Klemm, D.J., G.E. Morrison, T.J. Norberg-King, W.J. Peltier, and M.A. Heber. 1994. Short-term Methods for Estimating the Chronic Toxicity of Effluents and Receiving Water to Marine and Estuarine Organisms. USEPA Report No. EPA-600-4-91-003.
- c. SWRCB 1996. Procedures Manual for Conducting Toxicity Tests Developed by the Marine Bioassay Project. 96-1WQ.
- d. Weber, C.I., W.B. Horning, I.I., D.J. Klemm, T.W. Nieheisel, P.A. Lewis, E.L. Robinson, J. Menkedick and F. Kessler (eds). 1998. Short-term Methods for Estimating the Chronic Toxicity of Effluents and Receiving Waters to Marine and Estuarine Organisms. EPA/600/4-87/028. National Information Service, Springfield, VA.

If the performance goal for chronic toxicity is exceeded in any one test, then within 15 days of the exceedance, FPUD shall begin conducting six additional tests, bi-weekly, over a 12 week period. If the toxicity effluent limitation is exceeded in any of these six additional tests, then FPUD shall notify the San Diego Water Board. If the San Diego Water Board determines that the discharge consistently exceeds a toxicity performance goal, then FPUD shall initiate a TRE/TIE in accordance with the TRE workplan, Toxicity Reduction Evaluation Guidance for Municipal Wastewater Treatment Plants (USEPA 833-B-99-002, 1999), and USEPA TIE guidance documents (Phase I, EPA/600/6-91/005F, 1992; Phase II, EPA/600/R-92/080, 1993; and Phase III, EPA/600/R-92/081, 1993). Once the source of toxicity is identified, FPUD shall take all reasonable steps to reduce the toxicity to meet the chronic toxicity performance goal identified in section IV.A.2 of this Order.

Within 30 days of completion of the TRE/TIE, FPUD shall submit the results of the TRE/TIE, including a summary of the findings, data generated, a list of corrective actions necessary to achieve consistent compliance with all the toxicity limitations/performance goals of this Order and prevent recurrence of exceedances of those limitations/performance goals, and a time schedule for implementation of such corrective actions. The corrective actions and time schedule shall be modified at the direction of the San Diego Water Board.

If no toxicity is detected in any of these additional six tests, then FPUD may return to the testing frequency specified in the MRP.

VI. LAND DISCHARGE MONITORING REQUIREMENTS – NOT APPLICABLE

VII. RECLAMATION MONITORING REQUIREMENTS – NOT APPLICABLE

VIII. RECEIVING WATER MONITORING REQUIREMENTS – SURFACE WATER

The receiving water monitoring program required herein is also required by San Diego Water Board Order No. R9-2011-0016, which establishes limitations and conditions for discharges from the City of Oceanside, Oceanside OO. FPUD may conduct the required receiving water monitoring together with the City of Oceanside, US Marine Corps Base Camp Pendleton, and Genentech, as these entities discharge through the Oceanside OO.

Receiving water and sediment monitoring in the vicinity of the Oceanside OO shall be conducted as specified below. Station location, sampling, sampling preservation and analyses, when not specified, shall be by methods approved by the San Diego Water Board. The monitoring program may be modified by the San Diego Water Board at any time.

The receiving water and sediment monitoring program for the Oceanside OO may be conducted jointly with other dischargers to the Oceanside OO.

During monitoring events, if possible, sample stations shall be located using a land-based microwave positioning system or a satellite positioning system such as GPS. If an alternate navigation system is proposed, its accuracy should be compared to that of microwave and satellite based systems, and any compromises in accuracy shall be justified.

A. Surf Zone Water Quality Monitoring

All surf zone stations shall be monitored as follows.

1. Grab samples shall be collected and analyzed for total and fecal coliform and enterococcus bacteria at a minimum frequency of one time per week. As required by implementation procedures at section III.D of the Ocean Plan, measurement of enterococcus density shall be conducted at all stations where measurement of total and fecal coliform bacteria is required.

If a single sample exceeds any of the single sample bacterial standards, repeat sampling at that location shall be conducted to determine the extent and persistence of the exceedance. Repeat sampling shall be conducted within 24 hours of receiving analytical results and continued until the sample result is less than the single sample bacterial standards or until a sanitary survey is conducted to determine the source of the high bacterial densities.

Single sample bacterial standards include:

- i. Total coliform density will not exceed 10,000 per 100 ml; or
- ii. Fecal coliform density will not exceed 400 per 100 ml; or

- iii. Total coliform density will not exceed 1,000 per 100 ml when the ratio of fecal/total coliform exceeds 0.1;
 - iv. Enterococcus density will not exceed 104 per 100 ml.
2. At the same time Samples are collected from surf zone stations, the following information shall be recorded: observation of wind direction and speed; weather (cloudy, sunny, or rainy); current direction; tidal conditions; and observations of water color, discoloration, oil and grease; turbidity, odor, and materials of sewage origin in the water or on the beach; water temperature (°F); and status of the mouth of the Buena Vista Lagoon (open, closed, flow, etc.).

B. Near Shore Water Quality Monitoring

All near shore stations shall be monitored as follows.

1. Reduced Monitoring

If the San Diego Water Board determines that the effluent complies with the effluent limitations and performance goals at section IV.A of this Order and the receiving water limitations at section V.A of this Order at all times, only reduced near shore water quality monitoring specified below is required.

Table E-7. Near Shore Water Quality Reduced Monitoring Requirements

Determination	Units	Type of Sample	Minimum Frequency
Visual Observations	--	--	1/Month
Total Coliform Organisms	Number / 100 mL	Grab ¹	1/Month
Fecal Coliform Organisms	Number / 100 mL	Grab ¹	1/Month
Enterococcus	Number / 100 mL	Grab ¹	1/Month

¹ At the surface.

2. Intensive Monitoring

The intensive near shore water quality monitoring specified below is required during the 12-month period beginning November 1, 2013 through October 31, 2014, and must be submitted by December 1, 2014. This monitoring data will assist the San Diego Water Board in the evaluation of the Report of Waste Discharge. The intensive near shore water quality monitoring specified below may also be required if the San Diego Water Board determines that 1) the effluent does not at all times comply with the effluent limitations and performance goals of this Order; or 2) FPUD's discharge is causing or contributing to the receiving water limitations of this Order not being consistently achieved.

Table E-8. Near Shore Water Quality Intensive Monitoring Requirements

Determination	Units	Type of Sample	Minimum Frequency
Visual Observations	--	--	1/Month
Total Coliform Organisms	Number / 100 mL	Grab ¹	1/Month
Fecal Coliform Organisms	Number / 100 mL	Grab ¹	1/Month
Enterococcus	Number / 100 mL	Grab ¹	1/Month

¹ At the surface and mid-depth.

C. Off Shore Water Quality Monitoring

All off shore stations shall be monitored as follows.

1. Reduced Monitoring

If the San Diego Water Board determines that the effluent at all times complies with the effluent limitations and performance goals at section IV.A of this Order and the receiving water limitations at section V.A of this Order, only reduced off shore water quality monitoring specified below is required.

Table E-9. Off Shore Water Quality Reduced Monitoring Requirements

Determination	Units	Type of Sample	Minimum Frequency
Visual Observations	--	--	1/Month
Total Coliform Organisms	Number / 100 mL	Grab ¹	1/Month
Fecal Coliform Organisms	Number / 100 mL	Grab ¹	1/Month
Enterococcus	Number / 100 mL	Grab ¹	1/Month

¹ At surface and mid-depth.

2. Intensive Monitoring

The intensive off shore water quality monitoring specified below is required during the 12-month period beginning November 1, 2013 through October 31, 2014, and must be submitted by December 1, 2014. This monitoring data will assist the San Diego Water Board in the evaluation of the Report of Waste Discharge. The intensive off shore water quality monitoring specified below may also be required if the San Diego Water Board determines that 1) the effluent does not at all times comply with the effluent limitations and performance goals of this Order, or 2) the receiving water limitations of this Order are not being consistently achieved.

Table E-10. Off Shore Water Quality Intensive Monitoring Requirements

Determination	Units	Type of Sample	Minimum Frequency
Visual Observations	--	--	1/Month
Total Coliform Organisms	Number / 100 mL	Grab ¹	1/Month
Fecal Coliform Organisms	Number / 100 mL	Grab ¹	1/Month
Enterococcus	Number / 100 mL	Grab ¹	1/Month
Conductivity, Temperature, and Depth	Practical Salinity Units, °F, feet	Grab ²	1/Month
Dissolved Oxygen	mg/L	Grab ²	1/Month
Light Transmittance	percent	Instrument ²	1/Month
pH	standard units	Grab ³	1/Month

¹ At the surface and mid-depth.

² At the surface, mid-depth, and bottom.

³ At the surface.

D. Benthic Monitoring

The intensive monitoring specified below is required during the 12-month period beginning November 1, 2013 through October 31, 2014, and must be submitted by December 1, 2014. This monitoring data will assist the San Diego Water Board in the evaluation of the Report of Waste Discharge. The sediment monitoring specified below may also be required if the San Diego Water Board determines that 1) the effluent does not at all times comply with Effluent Limitations and Performance Goals of this Order or 2) FPUD’s discharge is causing or contributing to the receiving water limitations of this Order not being consistently achieved. Benthic monitoring shall be conducted at all off shore monitoring stations.

1. Sediment Characteristics. Analyses shall be performed on the upper 2 inches of core.

Table E-11. Sediment Monitoring Requirements

Determination	Units	Type of Sample	Minimum Frequency
Sulfides	mg/kg	Core	2/Year
Total Chlorinated Hydrocarbons	mg/kg	Core	2/Year
Biochemical Oxygen Demand (5-day @ 20°C)	mg/kg	Core	2/Year
Chemical Oxygen Demand	mg/kg	Core	2/Year
Particle Size Distribution	mg/kg	Core	2/Year
Arsenic	mg/kg	Core	1/Year
Cadmium	mg/kg	Core	1/Year
Total Chromium	mg/kg	Core	1/Year
Copper	mg/kg	Core	1/Year
Lead	mg/kg	Core	1/Year
Mercury	mg/kg	Core	1/Year
Nickel	mg/kg	Core	1/Year
Silver	mg/kg	Core	1/Year
Zinc	mg/kg	Core	1/Year
Cyanide	mg/kg	Core	1/Year
Phenolic Compounds	mg/kg	Core	1/Year
Radioactivity	pCi/kg	Core	1/Year

2. Infauna. Samples shall be collected with a Paterson, Smith-McIntyre, or orange-peel type dredge, having an open sampling area of not less than 124 square inches and a sediment capacity of not less than 210 cubic inches. The sediment shall be sifted through a 1-millimeter mesh screen and all organisms shall be identified to as low a taxon as possible.

Table E-12. Infauna Monitoring Requirements

Determination	Units	Sample Type	Minimum Frequency
Benthic Biota	Identification and enumeration	3 Grabs	2/Year

E. Additional Biological Monitoring – Demersal Fish and Macroinvertebrates

The intensive monitoring specified below is required during the 12-month period beginning November 1, 2013 through October 31, 2014, and must be submitted by December 1, 2014. This monitoring data will assist the San Diego Water Board in the evaluation of the Report of Waste Discharge, which is required to be submitted by FPUD within 180 days prior to the Order’s expiration date of September 27, 2017.

Table E-13. Demersal Fish and Macroinvertebrates Monitoring Requirements

Determination	Units	Minimum Frequency
Biological Transects	Identification and enumeration	Year 4

In rocky or cobble areas, a 30-meter band transect, 1 meter wide, shall be established on the ocean bottom. Operations at each underwater station shall include: (1) recording of water temperature (may be measured from a boat) and estimated visibility and pelagic macrobiota at each 10-foot depth increment throughout the water column and at the bottom; (2) recording of general bottom description; (3) enumeration by estimate of the larger plants and animals in the band transect area; (4) development of a representative photographic record of the sample area; and (5) within each band, three ¼-meter square areas shall be randomly selected, and all macroscopic plant and animal life shall be identified within each square to as low a taxon as possible, and measured. Sampling techniques will follow those employed by biologist divers of the California State Department of Fish and Game.

In sandy areas, a 30-meter band transect, 1 meter wide, shall be established on the ocean bottom. Operations at each underwater station shall include: (1) recording of water temperature (may be measured from a boat), and estimated visibility and pelagic macrobiota at each 10-foot depth increment throughout the water column and at the bottom; (2) recording of general bottom description; (3) recording of height, period, and crest direction of ripple marks; (4) recording of amount, description, and location of detritus on bottom; (5) creation of a representative photographic record of the area sampled; and (6) within each band, three cores of at least 42.5 cm² in area shall be randomly taken to a depth of 15 cm where possible, (the three cores may be taken from a boat) and the material removed sifted through at least a 1 mm mesh screen, and all organisms identified to as low a taxon as possible, enumerated, measured, and reproductive conditions assessed where feasible. Sampling techniques will follow those employed by biologist divers of the California State Department of Fish and Game.

For each epifauna and infauna, size frequency and distribution shall be shown for at least the three numerically largest populations identified to the lowest possible taxon and appropriate graphs showing the relationship between species frequency and population shall be plotted from each sample.

IX. OTHER MONITORING REQUIREMENTS

A. Kelp Bed Canopy

FPUD shall participate with other ocean dischargers in the San Diego Region in an annual regional kelp bed photographic survey. Kelp beds shall be monitored annually by means of vertical aerial infrared photography to determine the maximum aerial extent of the region’s coastal kelp beds within the calendar year. Surveys shall be conducted as close as possible to the time when kelp bed canopies cover the greatest area. The entire San Diego Region coastline, from the international boundary to the San Diego Region/Santa Ana Region boundary shall be photographed on the same day.

The images produced by the surveys shall be presented in the form of 1:24,000 scale photo-mosaic of the entire San Diego Region coastline. Onshore reference points, locations of all

ocean outfalls and diffusers, and the 30-foot mean lower low water (MLLW) and 60-foot (MLLW) depth contours shall be shown.

The aerial extent of the various kelp beds photographed in each survey shall be compared to that noted in surveys of previous years. Any significant losses which persist for more than one year shall be investigated by divers to determine the probable reason for the loss.

B. Regional Monitoring

The Discharger shall, as directed by the San Diego Water Board, participate with other regulated entities, other interested parties, and the San Diego Water Board in development, refinement, implementation, and coordination of regional monitoring and assessment programs to:

1. Determine the status and trends of conditions in ocean waters with regard to beneficial uses, e.g.
 - a. Are fish and shellfish safe to eat?
 - b. Is water quality safe for swimming?
 - c. Are ecosystems healthy?
2. Identify the stressors causing / contributing to conditions of concern;
3. Identify the sources of the stressors causing / contributing to conditions of concern; and
4. Evaluate the effectiveness (i.e., environmental outcomes) of actions taken to address such stressors and sources.

C. Solids Monitoring

FPUD shall report, annually, the volume of screenings, sludge [biosolids], grit, and other solids generated and/or removed during wastewater treatment and the locations where these waste materials are placed for disposal. Copies of all annual reports required by 40 CFR Part 503 shall be submitted to the San Diego Water Board at the same time they are submitted to the USEPA.

X. REPORTING REQUIREMENTS

A. General Monitoring and Reporting Requirements

1. FPUD shall comply with all Standard Provisions (Attachment D of this Order) related to monitoring, reporting, and recordkeeping.
2. Reports of marine monitoring surveys conducted to meet receiving water monitoring requirements of this MRP shall include, as a minimum, the following information:
 - a. A description of climatic and receiving water characteristics at the time of sampling (weather observations, floating debris, discoloration, wind speed and direction, swell or wave action, time of sampling, tide height, etc.).
 - b. A description of sampling stations, including differences unique to each station (e.g., station location, sediment grain size, distribution of bottom sediments, rocks, shell litter, calcareous worm tubes, etc.).

- c. A description of the sample collection and preservation procedures used in the survey.
 - d. A description of the specific method used for laboratory analysis.
 - e. An in-depth discussion of the results of the survey. All tabulations and computations shall be explained.
 - f. Annual reports will include detailed statistical analyses of all data. Methods may include, but are not limited to, various multivariate analyses such as cluster analysis, ordination, and regression. FPUD should also conduct additional analyses, as appropriate, to elucidate temporal and spatial trends in the data.
3. By March 1 of each year, FPUD shall submit an annual report to the San Diego Water Board and USEPA Region 9 that contains tabular and graphical summaries of the monitoring data obtained during the previous year. FPUD shall discuss the compliance record and corrective actions taken, or which may be taken, or which may be needed to bring the discharge into full compliance with the requirements of this Order and this MRP.

B. Self Monitoring Reports (SMRs)

1. The State Water Board and San Diego Water Board has notified FPUD to electronically submit Self-Monitoring Reports (SMRs) using the State Water Board’s California Integrated Water Quality System (CIWQS) Program Web site (<http://www.waterboards.ca.gov/ciwqs/index.html>). FPUD shall also submit hard copy SMRs, until notified otherwise. The CIWQS Web site will provide additional directions for SMR submittal in the event there will be service interruption for electronic submittal.
2. FPUD shall report in the SMR the results for all monitoring specified in this MRP under sections III through IX. FPUD shall submit monthly SMRs including the results of all required monitoring using USEPA-approved test methods or other test methods specified in this Order. If FPUD monitors any pollutant more frequently than required by this Order, the results of this monitoring shall be included in the calculations and reporting of the data submitted in the SMR.
3. Unless otherwise noted in the MRP, monitoring periods and reporting for all required monitoring shall be completed according to the following schedule:

Table E-14. Monitoring Periods and Reporting Schedule

Sampling Frequency/ Report Type	Monitoring Period Begins	Monitoring Period	SMR Due Date
Continuous	First day of the calendar month following the permit effective date or on permit effective date if that date is first day of the month.	All	First day of second calendar month following month of sampling.
1/Day	First day of the calendar month following the permit effective date or on permit effective date if that date is first day of the month.	(Midnight through 11:59 PM) or any 24-hour period that reasonably represents a calendar day for purposes of sampling.	First day of second calendar month following month of sampling.

Sampling Frequency/ Report Type	Monitoring Period Begins	Monitoring Period	SMR Due Date
1/Week	First Sunday of the calendar month following the permit effective date or on permit effective date if on a Sunday.	Sunday through Saturday	First day of second calendar month following month of sampling.
1/Month	First day of calendar month following permit effective date or on permit effective date if that date is first day of the month.	First day of calendar month through last day of calendar month	First day of second calendar month following month of sampling.
1/Quarter	Closest of January 1, April 1, July 1, or October 1 following (or on) permit effective date.	January 1 through March 31 April 1 through June 30 July 1 through September 30 October 1 through December 31	May 1 August 1 November 1 February 1
2/Year	Closest of January 1 or July 1 following (or on) permit effective date.	January 1 through June 30 July 1 through December 31	August 1 March 1
Significant Industrial User Compliance Status Report	Closest of January 1 or July 1 following (or on) permit effective date.	January 1 through June 30 July 1 through December 31	September 1 March 1
1/Year Pretreatment Program Compliance Schedule – progress report	January 1 following (or on) permit effective date.	January 1 through December 31	March 1
Biosolids Report	January 1 following (or on) permit effective date.	January 1 through December 31	February 19
Intensive Monitoring	November 1, 2013	November 1, 2013 through October 31, 2014	December 1, 2014

4. Reporting Protocols. FPUD shall report with each sample result the applicable reported Minimum Level (ML) and the current Method Detection Limit (MDL), as determined by the procedure in 40 CFR Part 136. For each numeric effluent limitation or performance goal for a parameter identified in Table B of the Ocean Plan, FPUD shall not use a ML greater than that specified in Appendix II of the Ocean Plan.

FPUD shall report the results of analytical determinations for the presence of chemical constituents in a sample using the following reporting protocols:

- a. Sample results greater than or equal to the reported ML shall be reported as measured by the laboratory (i.e., the measured chemical concentration in the sample).

- b. Sample results less than the minimum level (ML), but greater than or equal to the laboratory's MDL, shall be reported as "Detected, but Not Quantified," or DNQ. The estimated chemical concentration of the sample shall also be reported.

For the purposes of data collection, the laboratory shall write the estimated chemical concentration next to DNQ as well as the words "Estimated Concentration" (may be shortened to "Est. Conc."). The laboratory may, if such information is available, include numerical estimates of the data quality for the reported result. Numerical estimates of data quality may be percent accuracy (+ a percentage of the reported value), numerical ranges (low to high), or any other means considered appropriate by the laboratory.

- c. Sample results less than the laboratory's MDL shall be reported as "Not Detected," or ND.
- d. Dischargers are to instruct laboratories to establish calibration standards so that the ML value (or its equivalent if there is differential treatment of samples relative to calibration standards) is the lowest calibration standard. At no time is FPUD to use analytical data derived from extrapolation beyond the lowest point of the calibration curve.

5. Compliance Determination. Compliance with effluent limitations for reportable pollutants shall be determined using sample reporting protocols defined above and Attachment A of this Order. For purposes of reporting and administrative enforcement by the Regional and State Water Boards, FPUD shall be deemed out of compliance with effluent limitations if the concentration of the reportable pollutant in the monitoring sample is greater than the effluent limitation and greater than or equal to the reported ML.

6. Multiple Sample Data. When determining compliance with a measure of central tendency (arithmetic mean, geometric mean, median, etc.) of multiple sample analyses and the data set contains one or more reported determinations of DNQ or ND, FPUD shall compute the median in place of the arithmetic mean in accordance with the following procedure:

- a. The data set shall be ranked from low to high, ranking the reported ND determinations lowest, DNQ determinations next, followed by quantified values (if any). The order of the individual ND or DNQ determinations is unimportant.
- b. The median value of the data set shall be determined. If the data set has an odd number of data points, then the median is the middle value. If the data set has an even number of data points, then the median is the average of the two values around the middle unless one or both of the points are ND or DNQ, in which case the median value shall be the lower of the two data points where DNQ is lower than a value and ND is lower than DNQ.

7. FPUD shall submit SMRs in accordance with the following requirements:

- a. When electronic submittal of data is required and CIWQS does not provide for entry into a tabular format within the system, FPUD shall electronically submit the data in a tabular format as an attachment.
- b. Clearly identify violations of the waste discharge requirements; discuss corrective actions taken or planned; and the proposed time schedule for corrective actions.

Identified violations must include a description of the requirement that was violated and a description of the violation.

- c. When hard copies are required, SMRs must be submitted to the San Diego Water Board, signed and certified as required by the Standard Provisions (Attachment D of this Order), to the address listed below:

**9174 Sky Park Court, Suite 100
 San Diego, CA 92123-4340**

C. Discharge Monitoring Reports (DMRs)

1. At any time during the term of this permit, the State or San Diego Water Board may notify FPUD to electronically submit SMRs that will satisfy federal requirements for submittal of Discharge Monitoring Reports (DMRs). Until such notification is given, FPUD shall submit DMRs in accordance with the requirements described below.
2. DMRs must be signed and certified as required by the standard provisions (Attachment D of this Order). FPUD shall submit the original DMR and one copy of the DMR to the address listed below:

STANDARD MAIL	FEDEX/UPS/ OTHER PRIVATE CARRIERS
State Water Resources Control Board Division of Water Quality c/o DMR Processing Center PO Box 100 Sacramento, CA 95812-1000	State Water Resources Control Board Division of Water Quality c/o DMR Processing Center 1001 I Street, 15 th Floor Sacramento, CA 95814

3. All discharge monitoring results must be reported on the official USEPA pre-printed DMR forms (EPA Form 3320-1). Forms that are self-generated will not be accepted unless they follow the exact same format of USEPA Form 3320-1.

D. Other Reports

1. FPUD shall report the results of any chronic toxicity testing, TRE/TIE, FPUD Treatment Plant No. 1 Capacity Study, Sludge Disposal Report, and Pretreatment Report, as required by Special Provisions – VI.C. of this Order. FPUD shall submit reports with the first monthly SMR scheduled to be submitted on or immediately following the report due date.

Attachment F – Fact Sheet

Table of Contents

I.	Permit Information	F-3
II.	Facility Description	F-4
	A. Description of Wastewater and Biosolids Treatment or Controls.....	F-4
	B. Discharge Points and Receiving Waters	F-5
	C. Summary of Existing Requirements and Self-Monitoring Report (SMR) Data	F-6
	D. Compliance Summary	F-7
	E. Planned Changes	F-8
III.	Applicable Plans, Policies, and Regulations.....	F-8
	A. Legal Authorities.....	F-8
	B. California Environmental Quality Act (CEQA).....	F-8
	C. State and Federal Regulations, Policies, and Plans	F-8
	D. Impaired Water Bodies on CWA 303(d) List.....	F-10
	E. Other Plans, Policies and Regulations	F-10
IV.	Rationale For Effluent Limitations and Discharge Specifications	F-11
	A. Discharge Prohibitions.....	F-11
	B. Technology-Based Effluent Limitations	F-12
	C. Water Quality-Based Effluent Limitations (WQBELs)	F-14
	1. Scope and Authority	F-14
	2. Applicable Beneficial Uses and Water Quality Criteria and Objectives.....	F-15
	3. Determining the need for WQBELs	F-15
	4. WQBEL Calculations	F-20
	5. Whole Effluent Toxicity (WET).....	F-22
	D. Final Effluent Limitations	F-23
	1. Final Effluent Limitations	F-23
	2. Satisfaction of Anti-Backsliding Requirements	F-24
	3. Satisfaction of Antidegradation Policy	F-25
	4. Stringency of Requirements for Individual Pollutants	F-26
	E. Performance Goals.....	F-26
	F. Interim Effluent Limitations – Not Applicable	F-30
	G. Land Discharge Specifications – Not Applicable	F-30
	H. Reclamation Specifications	F-30
V.	Rationale for Receiving Water Limitations.....	F-30
VI.	Rationale for Monitoring and Reporting Requirements	F-30
	A. Influent Monitoring	F-31
	B. Effluent Monitoring.....	F-31
	C. Whole Effluent Toxicity Testing Requirements	F-31
	D. Receiving Water Monitoring	F-31
	E. Other Monitoring Requirements.....	F-32
VII.	Rationale for Provisions	F-33
	A. Standard Provisions	F-33
	B. Special Provisions	F-33
	1. Reopener Provisions	F-33

2. Special Studies and Additional Monitoring Requirements	F-33
3. Best Management Practices and Pollution Prevention – Not Applicable	F-35
4. Construction, Operation, and Maintenance Specifications – Not Applicable	F-35
5. Special Provisions for Wastewater Facilities	F-35
6. Other Special Provisions – Not Applicable	F-36
7. Compliance Schedules	F-36
VIII. Public Participation	F-36
A. Notification of Interested Parties	F-36
B. Written Comments	F-37
C. Public Hearing	F-37
D. Waste Discharge Requirements Petitions	F-37
E. Information and Copying	F-37
F. Register of Interested Persons	F-38
G. Additional Information	F-38

List of Tables

Table F-1. Facility Information	F-3
Table F-2. Facility Information	F-6
Table F-3. Historic Effluent Limitations and Monitoring Data at M-001	F-6
Table F-4. Historic Effluent Limitations and Monitoring Data at Discharge Point No. 001 (M-002)	F-7
Table F-5. Basin Plan Beneficial Uses	F-8
Table F-6. Ocean Plan Beneficial Uses	F-9
Table F-7. Summary of Technology-Based Effluent Limitations Based on Secondary Treatment Standards	F-13
Table F-8. Summary of Technology-Based Effluent Limitations Based on Table A of the Ocean Plan	F-14
Table F-9. RPA Results Summary	F-17
Table F-10. Pollutants Having Background Concentrations	F-21
Table F-11. Example Parameter Water Quality Objectives	F-21
Table F-12. Summary of Water Quality-based Effluent Limitations – Discharge Point No. 001	F-22
Table F-13.a. Technology Based Effluent Limitations at M-001	F-23
Table F-13.b. Effluent Limitations Based on Table B of the Ocean Plan at M-002 (Discharge Point No. 001)	F-24
Table F-14. Performance Goals Based on the Ocean Plan	F-27

ATTACHMENT F – FACT SHEET

As described in section II of this Order, this Fact Sheet includes the legal requirements and technical rationale that serve as the basis for the requirements of this Order.

This Order has been prepared under a standardized format to accommodate a broad range of discharge requirements for Dischargers in California. Only those sections or subsections of this Order that are specifically identified as “not applicable” have been determined not to apply to this Discharger. Sections or subsections of this Order not specifically identified as “not applicable” are fully applicable to this Discharger.

I. PERMIT INFORMATION

The following table summarizes administrative information related to the Facility.

Table F-1. Facility Information

WDID	9 000000115
Discharger	Fallbrook Public Utility District
Name of Facility	Fallbrook Public Utility District Treatment Plant No. 1
Facility Address	1425 South Alturas Road Fallbrook, CA 92028
Facility Contact, Title and Phone	Jack Bebee, Engineering and Planning Manager, (760) 728-1125
Authorized Person to Sign and Submit Reports	Jack Bebee, Engineering and Planning Manager, (760) 728-1125
Mailing Address	P.O. Box 2290, Fallbrook, CA 92028
Billing Address	Same as Mailing Address
Type of Facility	Municipal Publicly Owned Treatment Works (POTW)
Major or Minor Facility	Major
Threat to Water Quality	1
Complexity	A
Pretreatment Program	No
Reclamation Requirements	Producer and Distributor (regulated under separate waste discharge requirements (WDRs))
Facility Permitted Flow Rate	2.7 million gallons per day (MGD)
Facility Design Flow	2.7 MGD
Watershed	Pacific Ocean
Receiving Water	Pacific Ocean
Receiving Water Type	Ocean

- A.** The Fallbrook Public Utility District (hereinafter Discharger or FPUD) is the owner and operator of the Fallbrook Public Utility District Treatment Plant No. 1 (hereinafter Facility), a municipal POTW.

For the purposes of this Order, references to the “discharger” or “permittee” in applicable federal and state laws, regulations, plans, or policy are held to be equivalent to references to FPUD herein.

- B.** The Facility discharges treated secondary effluent through the Oceanside OO, which is owned and operated by the City of Oceanside, to the Pacific Ocean, a water of the United States, and currently regulated under Order No. R9-2006-002, which was adopted on April 12, 2006 and expires on June 1, 2011. The terms and conditions of the current Order have been automatically continued and remain in effect until new Waste Discharge Requirements and an NPDES permit are adopted and effective pursuant to this Order.
- C.** FPUD filed a Report of Waste Discharge (ROWD) and submitted an application for renewal of its WDRs and National Pollutant Discharge Elimination System (NPDES) permit on September 30, 2010.

II. FACILITY DESCRIPTION

A. Description of Wastewater and Biosolids Treatment or Controls

FPUD owns and operates the Facility, FPUD land outfall pipe, and FPUD sanitary sewer system. These facilities are collectively referred to as FPUD's Facilities in this Order. This Order establishes discharge prohibitions, limitations, and conditions to regulate discharges of effluent consisting of treated wastewater from FPUD's Facilities to the Pacific Ocean; these discharges were regulated by Order No. R9-2006-002 (NPDES permit No. CA0108031) that expired on June 1, 2011, but was administratively continued until the effective date of this Order.

FPUD provides wastewater collection, treatment, and disposal services for approximately 25,000 people utilizing residential service connections within the FPUD service area. Additionally, the Facility provides treatment and disposal services for approximately 10,000 gallons of wastewater generated by the Fallbrook US Naval Weapons Station. Currently, FPUD is not required to have an industrial pretreatment program since the Facility does not accept contributions from any industrial dischargers or sources subject to pretreatment standards.

The Facility is located at 1425 South Alturas Road, Fallbrook CA 92028 in San Diego County, adjacent to Fallbrook Creek. Wastewater treatment unit operations and processes at the Facility consist of mechanical bar screening, aerated grit removal, primary sedimentation, aeration and secondary clarification (activated sludge treatment process), chlorination, and filtration. Treated wastewater is discharged to the Pacific Ocean through the Oceanside OO. Secondary treatment design capacity is currently 2.70 MGD average daily flow. The annual average daily flow in 2008 was 1.75 MGD, and in 2009 was 1.71 MGD.

Screenings from the headworks and solids from grit removal at the Facility are collected on-site and trucked to a landfill in San Diego County, California. Sludge from the secondary treatment facilities is thickened aerobically, digested, and dewatered via centrifuge. Dewatered sludge are fed to a thermal dryer system to produce Class A EQ sewage sludge and disposed of via land application. If the dryer system is off-line, sewage sludge is dewatered via drying beds and hauled to a land application site in Yuma, Arizona by a contractor.

B. Discharge Points and Receiving Waters

The Facility discharges secondary effluent to the Oceanside OO via pump stations and a land outfall system. FPUD has a contractual agreement with the City of Oceanside to discharge up to 2.4 MGD of treated effluent through the Oceanside OO on an annual average basis.

The City of Oceanside owns and operates the Oceanside OO which begins at the City of Oceanside La Salina Wastewater Treatment Plant site just north of the mouth of the Loma Alta Creek and extends southwesterly approximately 8,850 feet offshore to a depth of approximately 100 feet. The Oceanside OO contains a 38-inch internal diameter steel pipe with a 1-inch thick cement mortar interior lining and 2.75-inch thick cement mortar outer jacket. The Oceanside OO has a 35.75-inch internal diameter. The Oceanside OO terminates with a 230-foot diffuser collinear with the rest of the outfall and extends to a depth of approximately 108 feet. The diffuser has fourteen 5-inch diameter ports and ten 4-inch diameter ports. The terminus of the diffuser is located at Latitude 33° 09' 46" North, Longitude 117° 23' 29" West.

The City of Oceanside has a contract with FPUD for the discharge of an average annual flowrate of 2.4 MGD of treated wastewater through the Oceanside OO, subject to waste discharge requirements contained in this Order. The City of Oceanside also has a contract with the United States Marine Corp Base Camp Pendleton (USMCBCP) for the discharge of up to 3.6 MGD of undisinfected secondary effluent through the Oceanside OO, subject to waste discharge requirements contained in Order No. R9-2008-0096 (NPDES Permit No. CA0109347). The City of Oceanside also has a contract with the industrial discharger Genentech to discharge brine flow up to 0.85 MGD through the Oceanside OO, subject to waste discharge requirements contained in Order No. R9-2008-0082 (NPDES Permit No. CA0109193). The combined permitted flow rate from all parties discharging through the Oceanside OO was 29.055 MGD.

Section II.B of the Fact Sheet for Order No. R9-2006-002 stated that the design capacity of the Oceanside OO is an average daily flow of 30 MGD, with a maximum rated peak-day capacity of 45 MGD. However, during an inspection of the Oceanside OO in 2009, the City of Oceanside determined that the outfall interior diameter is 35.75-inches, not 36-inches as shown in construction drawings. The City of Oceanside 2009 inspection also determined that a coating of soft muck is currently coating the entire interior circumference of the outfall pipe, reducing outfall capacity. Further, a sediment survey of the diffuser confirmed a sediment buildup, particularly near the end of the diffuser, also contributing to a loss of outfall capacity. The City of Oceanside submitted these findings to the San Diego Water Board in a 2010 Ocean Outfall Capacity Report. The report concludes that the current available capacity of the Oceanside OO is 22.6 MGD, significantly less than the previously reported 30 MGD. However, the City of Oceanside reported that this capacity is sufficient until 2015, when wet weather flows may result in an exceedance of the Oceanside OO capacity.

Below is a table displaying projected peak flows to the Oceanside OO.

Table F-2. Facility Information

Source	Peak Day Flow (MGD)	Projected Peak Flow (MGD) Under Wet Weather Conditions ¹		
		Current	Projected 2015	Projected 2020
City of Oceanside	15.75 ²	18.22 ⁷	19.93 ⁷	20.70 ⁷
Mission Basin Desalination Facility	1.3 ³	1.26	1.26 ³	1.26 ³
Genentech, Inc.	0.11 ²	0.11 ⁴	0.2 ⁴	0.2 ⁴
Camp Pendleton	2.8 ⁵	2.8 ⁵	2.8 ⁵	2.8 ⁵
FPUD	2.5 ⁶	2.5 ⁶	2.5 ⁶	2.5 ⁶
Total	21.18	24.89 ⁷	26.69 ⁷	27.46 ⁷

¹ From Ocean Outfall Capacity Evaluation Report (Carrollo Engineers, 2010). Assumes a 30 million gallon effluent storage pond at the City of Oceanside San Luis Rey Water Reclamation Facility (SLRWF) is not utilized.

² Observed maximum day flow during 2009.

³ Based on typical peak day brine flow observed in 2009.

⁴ Based on flow projections from Genentech, Inc.

⁵ Historic Camp Pendleton peak wet weather discharge to the Oceanside OO, which occurred during wet weather period in winter of 2005.

⁶ Historic FPUD peak wet weather discharge to the Oceanside OO, which occurred during wet weather period in winter 2005.

⁷ Combined projected peak inflow to the La Salina Wastewater Treatment Plant and SLRWF. Actual wet weather discharge flows from the two plants to the Oceanside OO will be lower than these projected values through the use of effluent storage capacity at the SLRWF.

Prior to 2016, the City of Oceanside plans to clean muck and debris from the interior of the outfall which will serve to increase the outfall capacity to 23.4 MGD and provide sufficient capacity until approximately 2025.

C. Summary of Existing Requirements and Self-Monitoring Report (SMR) Data

Effluent limitations contained in Order No. R9-2006-002 for discharges from the Facility and representative monitoring data obtained at Monitoring Location M-001 and M-002 (Discharge Point No. 001) are as follows:

Table F-3. Historic Effluent Limitations and Monitoring Data at M-001

Parameter	Units	Effluent Limitation			Monitoring Data (July 2005 – February 2010)		
		Average Monthly	Average Weekly	Maximum Daily	Highest Average Monthly Discharge	Highest Average Weekly Discharge	Highest Daily Discharge
Carbonaceous Biochemical Oxygen Demand (5-day @ 20°C) (CBOD ₅)	mg/L	25	40	--	16	32	--
	% Removal	85	--	--	93 ²	--	--
Total Suspended Solids (TSS)	mg/L	30	45	--	7.9	19	--
	% Removal	85	--	--	97 ²	--	--
pH	standard units	--	--	6.0 – 9.0 ¹	--	--	6.2 ² /7.6

¹ Between 6.0 and 9.0 at all times.

² Minimum.

Table F-4. Historic Effluent Limitations and Monitoring Data at Discharge Point No. 001 (M-002)

Parameter	Units	Effluent Limitation			Monitoring Data (July 2005 – February 2010)		
		Average Monthly	Average Weekly	Maximum Daily	Highest Average Monthly Discharge	Highest Average Weekly Discharge	Highest Daily Discharge
Oil and Grease	mg/L	25	40	75 ¹	ND	ND	ND
Settleable Solids	mL/L	1.0	1.5	3.0 ¹	1.0	0.26	5.0
Turbidity	NTU	75	100	225 ¹	4.7	16	53
Chronic Toxicity	TUc ²	--	--	88 ¹	--	--	25 ²

ND – Not detected

NR – Not Reported

¹ Applied as an instantaneous maximum effluent limitation.

² Chronic toxicity expressed as Chronic Toxicity Units (TUc) = 100/NOEL, where NOEL (No Observed Effect Level) is expressed as the maximum percent effluent or receiving water that causes no observable effect on a test organism.

D. Compliance Summary

1. Compliance Evaluation Inspections (CEI) of Treatment Plant No. 1 were conducted on October 22, 2007, January 15, 2009, and on April 8, 2010. Compliance issues noted by the inspectors were as follows:
 - a. On October 22, 2007, FPUD failed to properly report mass emission loadings for CBOD, TSS, and BOD between June 1, 2006 and the date of the inspection. Additionally, the inspector noted that oil and grease grab samples had not been collected according to the procedures under 40 CFR Part 136.
 - b. On February 28, 2008, FPUD did not report a value in the self-monitoring report for total suspended solids (TSS); however, the TSS value did not exceed the permit limitation.
 - c. On January 15, 2009, FPUD failed to properly report mass emission loadings for CBOD, TSS, and BOD between June 1, 2006 and the date of the inspection.
 - d. In the January 15, 2009 and April 8, 2010 CEI Reports, the inspector noted that FPUD's sampling methods for oil and grease were not in accordance with 40 CFR Part 136, as required in Order No. R9-20069-0002, Attachment E, Monitoring and Reporting Program.
2. From June 2006 to June 2010, according to the Discharger's reports, there were nine deficient monitoring violations and three effluent limitations violations. A notice of violation was issued for all of these violations on July 17, 2012.

E. Planned Changes

FPUD plans to upgrade existing process facilities without capacity increase.

III. APPLICABLE PLANS, POLICIES, AND REGULATIONS

The requirements contained in the proposed Order are based on the requirements and authorities described in this section.

A. Legal Authorities

This Order is issued pursuant to section 402 of the federal Clean Water Act (CWA) and implementing regulations adopted by the United States Environmental Protection Agency (USEPA) and chapter 5.5, division 7 of the California Water Code (CWC) (commencing with section 13370). It shall serve as a NPDES permit for point source discharges from this facility to surface waters. This Order also serves as WDRs pursuant to article 4, chapter 4, division 7 of the CWC (commencing with section 13260).

B. California Environmental Quality Act (CEQA)

Under CWC section 13389, this action to adopt an NPDES permit is exempt from the provisions of CEQA, Public Resources Code sections 21100 through 21177.

C. State and Federal Regulations, Policies, and Plans

1. Water Quality Control Plans. The Regional Water Quality Control Board (San Diego Water Board) adopted a *Water Quality Control Plan for the San Diego Basin* (hereinafter Basin Plan) on September 8, 1994 that designates beneficial uses, establishes water quality objectives, and contains implementation programs and policies to achieve those objectives. The Basin Plan was subsequently approved by the State Water Board on December 13, 1994. Subsequent revisions to the Basin Plan have also been adopted by the San Diego Water Board and approved by the State Water Board. The Basin Plan designates beneficial uses, establishes water quality objectives, and contains implementation programs and policies to achieve those objectives for all waters addressed through the plan.

Table F-5. Basin Plan Beneficial Uses

Discharge Point No.	Receiving Water Name	Beneficial Use(s)
001	Pacific Ocean	Industrial service supply; navigation; contact water recreation; non-contact water recreation; commercial and sport fishing; preservation of biological habitats of special significance; wildlife habitat; rare, threatened, or endangered species; marine habitat; aquaculture; migration of aquatic organisms; spawning, reproduction, and/or early development; and shellfish harvesting.

Requirements of this Order implement the Basin Plan.

- 2. California Ocean Plan.** The State Water Board adopted the *Water Quality Control Plan for Ocean Waters of California, California Ocean Plan* (hereinafter Ocean Plan) in 1972 and amended it in 1978, 1983, 1988, 1990, 1997, 2000, 2005, and 2009. The State Water Board adopted the latest amendment on September 15, 2009 and it became effective on March 10, 2010. The Ocean Plan is applicable, in its entirety, to point source discharges to the ocean. The Ocean Plan identifies beneficial uses of ocean waters of the State to be protected as summarized below:

Table F-6. Ocean Plan Beneficial Uses

Discharge Point No.	Receiving Water	Beneficial Uses
001	Pacific Ocean	Industrial water supply; water contact and non-contact recreation, including aesthetic enjoyment; navigation; commercial and sport fishing; mariculture; preservation and enhancement of designated Areas of Special Biological Significance (ASBS); rare and endangered species; marine habitat; fish migration; fish spawning and shellfish harvesting.

In order to protect beneficial uses, the Ocean Plan establishes water quality objectives and a program of implementation. Requirements of this Order implement the Ocean Plan.

- 3. Alaska Rule.** On March 30, 2000, USEPA revised its regulation that specifies when new and revised state and tribal water quality standards (WQS) become effective for CWA purposes (40 CFR 131.21, 65 Fed. Reg. 24641 (April 27, 2000)). Under the revised regulation (also known as the Alaska Rule), new and revised standards submitted to USEPA after May 30, 2000, must be approved by USEPA before being used for CWA purposes. The final rule also provides that standards already in effect and submitted to USEPA by May 30, 2000, may be used for CWA purposes, whether or not approved by USEPA.
- 4. Antidegradation Policy.** 40 CFR 131.12 requires that the State water quality standards include an antidegradation policy consistent with the federal policy. The State Water Board established California’s antidegradation policy in State Water Board Resolution No. 68-16. Resolution No. 68-16 incorporates the federal antidegradation policy where the federal policy applies under federal law. Resolution No. 68-16 requires that existing water quality be maintained unless degradation is justified based on specific findings. The San Diego Water Board’s Basin Plan implements, and incorporates by reference, both the State and federal antidegradation policies (San Diego Basin Plan Chapter 3, pages 3-2 & 3-3). The permitted discharge must be consistent with the antidegradation provision of 40 CFR 131.12 and State Water Board Resolution No. 68-16.
- 5. Anti-Backsliding Requirements.** Sections 402(o)(2) and 303(d)(4) of the CWA and 40 CFR 122.44(l) prohibit backsliding in NPDES permits. These anti-backsliding provisions require that effluent limitations in a reissued permit must be as stringent as those in the previous permit, with some exceptions in which limitations may be relaxed.

D. Impaired Water Bodies on CWA 303(d) List

On June 28, 2007, USEPA approved the list of impaired water bodies, prepared by the State Water Board pursuant to section 303(d) of the CWA, which are not expected to meet applicable water quality standards after implementation of technology-based effluent limitations for point sources. The 303(d) list for waters in the vicinity of the Oceanside OO include:

1. 0.5 miles of the Pacific Ocean at the mouth of the San Luis Rey River for indicator bacteria;
2. 1.1 miles of the Pacific Ocean shoreline at the mouth of Loma Alta Creek for indicator bacteria;
3. 1.2 miles of the Pacific Ocean shoreline at Buena Vista Creek for indicator bacteria.

Impairment has been detected in the above waters. Some of the receiving water monitoring locations required by this permit may be within the current 303(d) listed waterbodies. The San Diego Water Board will take these considerations into account the fact when determining compliance. An applicable Total Maximum Daily Load has not been adopted for this pollutant/waterbody combination and a waste load allocation has not been assigned for FPUD's discharge under this Order.

E. Other Plans, Policies and Regulations

1. **Secondary Treatment Regulations.** 40 CFR Part 133 establishes the minimum levels of effluent quality to be achieved by secondary treatment. These limitations, established by the USEPA, are incorporated into this Order, except where more stringent limitations are required by other applicable plans, policies, or regulations.
2. **Storm Water.** Sewage treatment works with a design flow of 1.0 MGD or greater are required to comply with Water Quality Order No. 97-03-DWQ (NPDES General Permit No. CAS000001), WDRs for Dischargers of Storm Water Associated with Industrial Activity, Excluding Construction Activities. FPUD is currently regulated under the General Permit, which is not incorporated into this Permit by reference.

F. Provisions and Requirements Implementing State Law

Pursuant to CWC section 13263, the provisions and requirements contained in this Order that implement State law shall take into consideration the beneficial uses to be protected, the water quality objectives reasonably required for that purpose, other waste discharges, the need to prevent nuisance, and the provisions of CWC section 13241.

The beneficial uses (CWC section 13241 (a)) and water quality objectives (CWC section 13241 (c)) serve as the basis for the development of the water quality based effluent limitations as described in section IV. Of the Fact Sheet. Other waste discharges are described in paragraph II.B of this fact sheet. There is a clear need to prevent potential nuisance conditions resulting from the inadequate treatment of sewage.

In addition to the above, CWC section 13241 requires consideration of:

Section 13241(b) Environmental characteristics of the hydrographic unit under consideration, including the quality of water available thereto. As noted in paragraph III.D, some of the receiving water monitoring locations required by this permit may be within the current 303(d) listed waterbodies.

Section 13241(d) Economic considerations. No party has submitted current or future cost information on the facility. Based upon the State Water Board's Wastewater User Charge Survey Report, dated May 2008, the monthly rates for agencies with both collection and treatment systems ranged from \$25 to \$82.50, with an average rate of \$44.22 as compared to FPUD's reported monthly rate of \$42.78.

Section 13241(e) The need to develop housing within the region. FPUD has not indicated that development in the area requires expansion of the capacity of the treatment facility.

Section 13241(f) The need to develop and use recycled water. The San Diego Water Board supports FPUD's efforts to develop and to supply recycle water to users. The need to supply recycled water is the reason that the San Diego Water Board is prescribing a time schedule for FPUD to comply Ocean Plan total residual chlorine standards.

IV. RATIONALE FOR EFFLUENT LIMITATIONS AND DISCHARGE SPECIFICATIONS

The CWA requires point source dischargers to control the amount of conventional, non-conventional, and toxic pollutants that are discharged into the waters of the United States. The control of pollutants discharged is established through effluent limitations and other requirements in NPDES permits. There are two principal bases for effluent limitations in the CFR: 40 CFR 122.44(a) requires that permits include applicable technology-based limitations and standards; and 40 CFR 122.44(d) requires that permits include water quality-based effluent limitations (WQBELs) to attain and maintain applicable numeric and narrative water quality criteria to protect the beneficial uses of the receiving water.

A. Discharge Prohibitions

This Order retains the discharge prohibitions from Order No. R9-2006-002, as described below. Compliance determination language is included in section VII of this Order to accurately describe how violations of these prohibitions are determined. Discharges from the Facility to surface waters in violation of prohibitions contained in this Order are violations of the CWA and therefore are subject to third party lawsuits. Discharges from the Facility to land in violation of prohibitions contained in this Order are violations of the CWC and are not subject to third party lawsuits under the CWA because the CWC does not contain provisions allowing third party lawsuits.

1. Prohibitions III.A, III.B, and III.C of this Order are based on Order No. R9-2006-002 and are included in order to clearly define what types of discharges are prohibited.

2. This Order prohibits the discharge of wastes in excess of the design criteria for Treatment Plant No. 1. As such, Prohibitions III.C prohibit the discharge of wastes in excess of the design criteria for the Facility.
3. CWC section 13243 provides that the San Diego Water Board, in a water quality control plan, may specify certain conditions where the discharge of wastes, or certain types of wastes, that could affect the quality of waters in the State is prohibited. This Order includes the Basin Plan and Ocean Plan prohibitions as Discharge Prohibitions, section III.D and E.

Order No. R9-2006-002 prohibited discharges of waste to Areas of Special Biological Significance and the discharge of sludge to the ocean. Because these prohibitions are expressly included in the Ocean Plan prohibitions, which are included in this Order as prohibition section III.D and for convenience listed in Attachment G of this Order, these requirements are not retained in the prohibitions of this Order.

B. Technology-Based Effluent Limitations

1. Scope and Authority

Section 301(b) of the CWA and implementing USEPA permit regulations at 40 CFR 122.44 require that permits include conditions meeting applicable technology-based requirements at a minimum, and any more stringent effluent limitations necessary to meet applicable water quality standards. Discharges authorized by this Order must meet minimum federal technology-based requirements based on Secondary Treatment Standards at 40 CFR Part 133. Discharges must also meet technology-based effluent limitations (TBELs) based on Ocean Plan Table A.

Regulations promulgated in 40 CFR 125.3(a)(1) require TBELs for municipal Dischargers to be placed in NPDES permits based on Secondary Treatment Standards or Equivalent to Secondary Treatment Standards.

The Federal Water Pollution Control Act Amendments of 1972 (PL 92-500) established the minimum performance requirements for POTWs [defined in 40 CFR 304(d)(1)]. Section 301(b)(1)(B) of that Act requires that such treatment works must, as a minimum, meet effluent limitations based on secondary treatment as defined by the USEPA Administrator.

Based on this statutory requirement, USEPA developed secondary treatment regulations, which are specified in 40 CFR Part 133. These technology-based regulations apply to all municipal wastewater treatment plants and identify the minimum level of effluent quality attainable by secondary treatment in terms of biochemical oxygen demand (BOD₅), TSS, and pH.

2. Applicable Technology-Based Effluent Limitations

- a. **Federal Regulations.** 40 CFR Part 133 establishes the minimum weekly and monthly average level of effluent quality attainable by secondary treatment for BOD₅ and TSS. 40 CFR 133.102(a)(4) allows for effluent limitations for

carbonaceous biological oxygen demand (CBOD₅) to be applied in lieu of effluent limitations for BOD₅ where BOD₅ may not provide a reliable measure of the oxygen demand of the effluent. USEPA has determined that a 30-day average effluent limitation of 25 mg/L and a 7-day average effluent limitation of 40 mg/L are effectively equivalent to the secondary treatment standards for BOD₅.

- b. 40 CFR 133.102, in describing the minimum level of effluent quality attainable by secondary treatment, states that the 30-day average percent removal of BOD₅ and TSS shall not be less than 85 percent. This Order contains a limitation requiring an average of 85 percent removal of CBOD₅ and TSS over each calendar month.

The secondary treatment regulations at 40 CFR Part 133 also require that pH be maintained between 6.0 and 9.0 standard units.

These TBELs are applicable to each of the POTWs prior to the commingling of their respective effluents with any other wastewater. Thus, compliance with these effluent limitations must be determined at internal outfall locations upstream of the location where these wastewaters commingle with other wastewaters.

TBELs based on secondary treatment standards for CBOD₅, TSS, and pH are summarized in the following table.

Table F-7. Summary of Technology-Based Effluent Limitations Based on Secondary Treatment Standards

Parameter	Units	Effluent Limitations				
		Average Monthly	Average Weekly	Maximum Daily	Instantaneous Minimum	Instantaneous Maximum
CBOD ₅	mg/L	25	40	--	--	--
	Lbs/day	560	900			
	% Removal	85	--	--	--	--
TSS	mg/L	30	45	--	--	--
	Lbs/day	680	1,000			
	% Removal	85	--	--	--	--
pH	standard units	--	--	--	6.0	9.0

- c. **Ocean Plan.** The Ocean Plan is applicable, in its entirety, to point source discharges to the ocean. Therefore, the discharge of wastewater to the Pacific Ocean at Discharge Point No. 001 is subject to the Ocean Plan.

The Ocean Plan establishes water quality objectives, general requirements for management of waste discharged to the ocean, effluent quality requirements for waste discharges, discharge prohibitions, and general provisions. Further, Table A of the Ocean Plan establishes TBELs for POTWs and industrial discharges for which effluent limitation guidelines have not been established. Order No. R9-2006-002 established numeric effluent limitations based on Table A of the Ocean

Plan at Monitoring Location M-001 or M-002. Because the Table A effluent limitations are technology-based, the San Diego Water Board finds that the Table A effluent limitations are applicable to Treatment Plant No. 1 and FPUD shall be responsible for achieving compliance with the effluent limitations prior to the contributing wastewaters commingling with effluent from other facilities discharging effluent at the Oceanside OO.

Because secondary treatment standards contain effluent limitations for TSS that are more stringent than Table A of the Ocean Plan, the more stringent effluent limitations for TSS will be applied to discharges from Treatment Plant No. 1. The TBELs from the Ocean Plan are summarized below:

Table F-8. Summary of Technology-Based Effluent Limitations Based on Table A of the Ocean Plan

Parameter	Units	Effluent Limitations				
		Average Monthly	Average Weekly	Maximum Daily	Instantaneous Minimum	Instantaneous Maximum
Oil and Grease	mg/L	25	40	--	--	75
	Lbs/day	560	900			1700
Settleable Solids	mL/L	1.0	1.5	--	--	3.0
Turbidity	NTU	75	100	--	--	225
pH	standard units	--	--	--	6.0	9.0

C. Water Quality-Based Effluent Limitations (WQBELs)

1. Scope and Authority

Section 301(b) of the CWA and 40 CFR 122.44(d) require that permits include limitations more stringent than applicable federal technology-based requirements where necessary to achieve applicable water quality standards.

40 CFR 122.44(d)(1)(i) mandates that permits include effluent limitations for all pollutants that are or may be discharged at levels that have reasonable potential to cause or contribute to an exceedance of a water quality standard, including numeric and narrative objectives within a standard. Where reasonable potential has been established for a pollutant, but there is no numeric criterion or objective for the pollutant, WQBELs must be established using: (1) USEPA criteria guidance under CWA section 304(a), supplemented where necessary by other relevant information; (2) an indicator parameter for the pollutant of concern; or (3) a calculated numeric water quality criterion, such as a proposed state criterion or policy interpreting the state's narrative criterion, supplemented with other relevant information, as provided in 40 CFR 122.44(d)(1)(vi).

The process for determining reasonable potential and calculating WQBELs when necessary is intended to protect the designated uses of the receiving water as specified in the Basin Plan and Ocean Plan, and achieve applicable water quality objectives and criteria that are contained in the Ocean Plan.

2. Applicable Beneficial Uses and Water Quality Criteria and Objectives

The Basin Plan and Ocean Plan designate beneficial uses, establishes water quality objectives, and contain implementation programs and policies to achieve those objectives for all waters.

- a. Basin Plan.** The beneficial uses specified in the Basin Plan applicable to the Pacific Ocean are summarized in section III.C.1 of this Fact Sheet. The Basin Plan includes water quality objectives for pH applicable to the receiving water.

The Basin Plan states, “*The terms and conditions of the State Board’s “Water Quality Control Plan for Ocean Waters of California” (Ocean Plan), “Water Quality Control Plan for Control of Temperature in the Coastal and Interstate Waters and Enclosed Bays and Estuaries of California” (Thermal Plan), and any revisions thereto are incorporated into this Basin Plan by reference. The terms and conditions of the Ocean Plan and Thermal Plan apply to the ocean waters within this Region.*”

- b. Ocean Plan.** The beneficial uses specified in the Ocean Plan for the Pacific Ocean are summarized in section III.C.2 of this Fact Sheet. The Ocean Plan also includes water quality objectives for the ocean receiving water for bacterial characteristics, physical characteristics, chemical characteristics, biological characteristics, and radioactivity.

Table B of the Ocean Plan includes the following water quality objectives for toxic pollutants and whole effluent toxicity:

- i. 6-month median, daily maximum, and instantaneous maximum objectives for 21 chemicals and chemical characteristics, including total residual chlorine and chronic toxicity, for the protection of marine aquatic life.
- ii. 30-day average objectives for 20 non-carcinogenic chemicals for the protection of human health.
- iii. 30-day average objectives for 42 carcinogenic chemicals for the protection of human health.
- iv. Daily maximum objectives for acute and chronic toxicity.

3. Determining the need for WQBELs

Order No. R9-2006-002 contained effluent limitations for non-conventional and toxic pollutant parameters in Table B of the California Ocean Plan. For this Order, the need for effluent limitations based on water quality objectives in Table B of the Ocean Plan was re-evaluated in accordance with 40 CFR 122.44(d) and guidance for statistically determining the “reasonable potential” for a discharged pollutant to exceed an objective, as outlined in the revised *Technical Support Document for Water Quality-based Toxics Control* (TSD; EPA/505/2-90-001, 1991) and the Ocean Plan Reasonable Potential Analysis (RPA) Appendix VI that was adopted by the State Water Board on September 15, 2009. The statistical approach combines knowledge of effluent variability (as estimated by a coefficient of variation) with the

uncertainty due to a limited amount of effluent data to estimate a maximum effluent value at a high level of confidence. This estimated maximum effluent value is based on a lognormal distribution of daily effluent values. Projected receiving water values (based on the estimated maximum effluent value or the reported maximum effluent value and minimum probable initial dilution) can then be compared to the appropriate objective to determine potential for an exceedance of that objective and the need for an effluent limitation. According to the Ocean Plan amendment, the RPA can yield three endpoints: 1) Endpoint 1, an effluent limitation is required and monitoring is required; 2) Endpoint 2, an effluent limitation is not required and the San Diego Water Board may require monitoring; 3) Endpoint 3, the RPA is inconclusive, monitoring is required, and an existing effluent limitation may be retained or a permit reopener clause may be included to allow inclusion of an effluent limitation if future monitoring warrants the inclusion. Endpoint 3 is typically the result when there are fewer than 16 data points and all are censored data (i.e., below quantitation or method detection levels for an analytical procedure).

The implementation provisions for Table B in section III.C of the Ocean Plan specify that the minimum initial dilution is the lowest average initial dilution within any single month of the year. Dilution estimates are to be based on observed waste flow characteristics, observed receiving water density structure, and the assumption that no currents of sufficient strength to influence the initial dilution process flow across the discharge structure. Before establishing a dilution credit for a discharge, it must first be determined if, and how much, receiving water is available to dilute the discharge. Prior to issuance of Order No. R9-2006-002, the State Water Board had determined the minimum initial dilution factor (D_m), for the Oceanside OO to be 87 to 1. This determination was based on flow from the Facility and additional discharges from the City of Oceanside's La Salina and San Luis Rey wastewater treatment plants, the Mission Basin Desalting Facility, USMC Camp Pendleton, and Genentech, yielding a total flow rate of 29.055 MGD. No additions or modifications to the Facility or the Oceanside OO have been proposed that would alter the previously determined dilution characteristics. Therefore, the previous D_m of 87 to 1 will be retained in the current Order and applied to WQBELs established herein.

Conventional pollutants were not considered as part of the RPA. TBELs for these pollutants are included in this Order as described in section IV.B of this Fact Sheet.

Using the RPcalc 2.0 software tool developed by the State Water Board for conducting reasonable potential analyses, the San Diego Water Board has conducted the RPA for the constituents in Table F-9. For parameters without reasonable potential a narrative limit statement to comply with all Ocean Plan objectives requirements is provided. This Order includes desirable maximum effluent concentrations for constituents that do not have reasonable potential which were derived using the effluent limitation determination procedure described above and are referred to in this Order as "performance goals", not as enforceable "numeric effluent limitations". FPUD is required to monitor for these constituents as stated in the MRP (Attachment E of this Order) to gather data for use in reasonable potential analyses for future permit renewals.

Effluent data provided in FPU D's monitoring reports for the Facility from July 2006 through July 2009 were used in the RPA. A minimum probable initial dilution of 87 to 1 was considered in this evaluation.

A summary of the RPA results is provided below:

Table F-9. RPA Results Summary

Parameter	Units	n ¹	MEC ^{2,4}	Most Stringent Criteria	Background	RPA Endpoint ³
Arsenic	µg/L	7	<0.0044	8 ⁵	3 ⁶	3
Cadmium	µg/L	7	<0.002	1 ⁵	0	3
Chromium (VI)	µg/L	7	2.3	2 ⁵	0	3
Copper	µg/L	7	26	3 ⁵	2 ⁶	2
Lead	µg/L	7	<0.003	2 ⁵	0	3
Mercury	µg/L	7	0.12	0.04 ⁵	0.0005 ⁶	3
Nickel	µg/L	7	3.3	5 ⁵	0	2
Selenium	µg/L	7	<0.008	15 ⁵	0	3
Silver	µg/L	7	<0.006	0.7 ⁵	0.16 ⁶	3
Zinc	µg/L	7	51	20 ⁵	8 ⁶	2
Cyanide	µg/L	7	20	1 ⁵	0	3
Total Residual Chlorine	µg/L	1617	6600	2 ⁵	0	1
Ammonia	µg/L	68	26,000	600 ⁵	0	2
Acute Toxicity	TUa	12	0.41	0.3 ⁷	0	2
Chronic Toxicity ⁸	TUc	20	25	1 ⁷	0	2
Phenolic Compounds ⁹	µg/L	7	0.730	30 ⁵	0	2
Chlorinated Phenolics ¹⁰	µg/L	7	<0.096	1 ⁵	0	3
Endosulfan ¹¹	µg/L	7	0.049	0.009 ⁵	0	3
Endrin	µg/L	7	<0.0019	0.002 ⁵	0	3
HCH ¹²	µg/L	7	0.014	0.004 ⁵	0	3
Radioactivity	pCi/L			1 ³	0	
Acrolein	µg/L	4	<1.3	220 ¹⁴	0	3
Antimony	µg/L	4	<0.006	1,200 ¹⁴	0	3
Bis(2-chloroethoxy)methane	µg/L	4	<0.096	4.4 ¹⁴	0	3
Bis(2-chloroisopropyl)ether	µg/L	4	<0.096	1,200 ¹⁴	0	3
Chlorobenzene	µg/L	4	<0.36	570 ¹⁴	0	3
Chromium (III) ¹⁵	µg/L	4	2.3	190,000 ¹⁴	0	3
Di-n-butyl phthalate	µg/L	4	0.21	3,500 ¹⁴	0	3
Dichlorobenzenes ¹⁶	µg/L	4	<0.096	5,100 ¹⁴	0	3
Diethyl phthalate	µg/L	4	0.89	33,000 ¹⁴	0	2
Dimethyl phthalate	µg/L	4	0.87	820,000 ¹⁴	0	2
4,6-Dinitro-2-methylphenol	µg/L	4	<0.19	220 ¹⁴	0	3
2,4-Dinitrophenol	µg/L	NA	NA	4.0 ¹⁴	0	--
Ethylbenzene	µg/L	4	<0.25	4,100 ¹⁴	0	3
Fluoranthene	µg/L	4	<0.096	15 ¹⁴	0	3
Hexachlorocyclopentadiene	µg/L	4	<0.096	58 ¹⁴	0	3
Nitrobenzene	µg/L	4	<0.096	4.9 ¹⁴	0	3
Thallium	µg/L	4	<0.007	2 ¹⁴	0	3
Toluene	µg/L	4	0.69	85,000 ¹⁴	0	3
Tributyltin	µg/L	4	0.028	0.0014 ¹⁴	0	3
1,1,1-Trichloroethane	µg/L	4	<0.3	540,000 ¹⁴	0	3
Acrylonitrile	µg/L	4	<0.7	0.10 ¹⁴	0	3
Aldrin	µg/L	4	<0.0014	0.000022 ¹⁴	0	3

Parameter	Units	n ¹	MEC ^{2,4}	Most Stringent Criteria	Background	RPA Endpoint ³
Benzene	µg/L	4	<0.28	5.9 ¹⁴	0	3
Benidine	µg/L	4	<0.96	0.000069 ¹⁴	0	3
Beryllium	µg/L	4	<0.0009	0.033 ¹⁴	0	3
Bis(2-chloroethyl) ether	µg/L	4	<0.096	0.045 ¹⁴	0	3
Bis(2-ethylhexyl) phthalate	µg/L	4	9.7	3.5 ¹⁴	0	2
Carbon tetrachloride	µg/L	4	<0.28	0.90 ¹⁴	0	3
Chlordane	µg/L	4	<0.019	0.000023 ¹⁴	0	3
Chlorodibromomethane	µg/L	4	1.1	8.6 ¹⁴	0	2
Chloroform	µg/L	4	9.2	130 ¹⁴	0	2
DDT ¹⁷	µg/L	2	<0.002	0.00017 ¹⁴	0	3
1,4-Dichlorobenzene	µg/L	4	0.46	18 ¹⁴	0	3
3,3-Dichlorobenzidine	µg/L	4	<0.38	0.0081 ¹⁴	0	3
1,2-Dichloroethane	µg/L	4	<0.28	28 ¹⁴	0	3
1,1-Dichloroethylene	µg/L	4	<0.32	0.9 ¹⁴	0	3
Dichlorobromomethane	µg/L	4	2.8	6.2 ¹⁴	0	2
Dichloromethane	µg/L	4	<0.7	450 ¹⁴	0	3
1,3-Dichloropropene	µg/L	4	<0.32	8.9 ¹⁴	0	3
Dieldrin	µg/L	4	<0.0019	0.00004 ¹⁴	0	3
2,4-Dinitrotoluene	µg/L	4	1.3	2.6 ¹⁴	0	3
1,2-Diphenylhydrazine	µg/L	4	<0.096	0.16 ¹⁴	0	3
Halomethanes ¹⁸	µg/L	4	5.3	130 ¹⁴	0	3
Heptachlor	µg/L	4	<0.0028	0.00005 ¹⁴	0	3
Heptachlor Epoxide	µg/L	4	<0.0024	0.00002 ¹⁴	0	3
Hexachlorobenzene	µg/L	4	<0.096	0.00021 ¹⁴	0	3
Hexachlorobutadiene	µg/L	4	<0.1	14 ¹⁴	0	3
Hexachloroethane	µg/L	4	<0.19	2.5 ¹⁴	0	3
Isophorone	µg/L	4	<0.096	730 ¹⁴	0	3
N-nitrosodimethylamine	µg/L	4	0.095	7.3 ¹⁴	0	3
N-nitrosodi-N-propylamine	µg/L	4	<0.096	0.38 ¹⁴	0	3
N-nitrosodiphenylamine	µg/L	4	<0.096	2.5 ¹⁴	0	3
PAHs ¹⁹	µg/L	4	<0.096	0.0088 ¹⁴	0	3
PCBs ²⁰	µg/L	4	<0.1	0.000019 ¹⁴	0	3
TCDD equivalents ²¹	pg/L	4	0.0009	0.0000039 ¹⁴	0	1
1,1,2,2-Tetrachloroethane	µg/L	4	<0.24	2.3 ¹⁴	0	3
Tetrachloroethylene	µg/L	4	<0.26	2.0 ¹⁴	0	3
Toxaphene	µg/L	3	<0.069	0.00021 ¹⁴	0	3
Trichloroethylene	µg/L	4	<0.26	27 ¹⁴	0	3
1,1,2-Trichloroethane	µg/L	4	<0.3	9.4 ¹⁴	0	3
2,4,6-Trichlorophenol	µg/L	4	0.23	0.29 ¹⁴	0	3
Vinyl Chloride	µg/L	4	<0.26	36 ¹⁴	0	3

Parameter	Units	n ¹	MEC ^{2,4}	Most Stringent Criteria	Background	RPA Endpoint ³
-----------	-------	----------------	--------------------	-------------------------	------------	---------------------------

NA = Not Available

- 1 Number of data points available for the RPA.
- 2 If there is a detected value, the highest reported value is summarized in the table. If there are no detected values, the lowest MDL is summarized in the table.
- 3 End Point 1 – RP determined, limit required, monitoring required.
End Point 2 – Discharger determined not to have RP, monitoring may be established.
End Point 3 – RPA was inconclusive, carry over previous limits if applicable, and establish monitoring.
- 4 Note that the reported MEC does not account for dilution. The RPA does account for dilution; therefore it is possible for a parameter with an MEC in exceedance of the most stringent criteria not to present a RP (i.e. Endpoint 1).
Based on the 6-Month Median in the Table B of the Ocean Plan.
- 5 Based on the 6-Month Median in the Table B of the Ocean Plan.
- 6 Background concentrations contained in Table C of the Ocean Plan.
- 7 Based on the Daily Maximum in Table B of the Ocean Plan.
- 8 Chronic toxicity expressed as Chronic Toxicity Units (TUc) = 100/NOEL, where NOEL (No Observed Effect Level) is express as the maximum percent effluent of receiving water that causes no observable effect on a test organism.
- 9 Non-chlorinated phenolic compounds represent the sum of 2,4-dimethylphenol, 4,6-Dinitro-2-methylphenol, 2,3-dinitrophenol, 2-methylphenol, 4-methylphenol, 2-nitrophenol, 4-nitrophenol, and phenol.
- 10 Chlorinated phenolic compounds represent the sum of 4-chloro-3-methylphenol, 2-chlorophenol, pentachlorophenol, 2,4,5-trichlorophenol, and 2,4,6-trichlorophenol.
- 11 Endosulfan represents the sum of alpha-endosulfan, beta-endosulfan, and endosulfan sulfate.
- 12 HCH (hexachlorocyclohexane) represents the sum of the alpha, beta, gamma (Lindane), and delta isomers of hexachlorocyclohexane.
- 13 Not to exceed limits specified in Title 17, Division 1, Chapter 5, Subchapter 4, Group 3, Article 3, Section 30253 of the California Code of Regulations. Radioactivity at levels that exceed the applicable criteria are not expected in the discharge.
- 14 Based on 30-Day Average in Table B of the Ocean Plan.
- 15 Chromium data was reported as Total Chromium and is summarized under Chromium (VI).
- 16 Dichlorobenzenes represent the sum of 1,2- and 1,3-dichlorobenzene.
- 17 DDT represents the sum of 4,4'DDT; 2,4'DDT; 4,4'DDE; 2,4'DDE; 4,4'DDD; and 2,4'DDD.
- 18 Halomethanes represent the sum of bromoform, bromomethane (methyl bromide), and chloromethane (methyl chloride).
- 19 PAHs (polynuclear aromatic hydrocarbons) represent the sum of acenaphthalene; anthracene; 1,2-benzanthracene; 3,4-benzofluoranthene; benzo[k]fluoranthene; 1,12-benzoperylene; benzo[a]pyrene; chrysene; dibenzo[a,h]anthracene; fluorene; indeno[1,2,3-cd]pyrene; phenanthrene; and pyrene.
- 20 PCBs (polychlorinated biphenyls) represent the sum of chlorinated biphenyls whose analytical characteristics resemble those of Aroclor-1016, Aroclor-1221, Aroclor-1232, Aroclor-1242, Aroclor-1248, Aroclor-1254, and Arcolor-1260.
- 21 TCDD equivalents represent the sum of concentrations of chlorinated dibenzodioxins (2,3,7,8-CDDs) and chlorinated dibenzofurans (2,3,7,8-CDFs) multiplied by their respective toxicity factors, as shown by the table below. USEPA Method 8280 may be used to analyze TCDD equivalents.

Isomer Group	Toxicity Equivalence Factor
2,3,7,8 – tetra CDD	1.0
2,3,7,8 – penta CDD	0.5
2,3,7,8 – hexa CDD	0.1
2,3,7,8 – hepta CDD	0.01
octa CDD	0.001
2,3,7,8 – tetra CDF	0.1
1,2,3,7,8 – penta CDF	0.05
2,3,4,7,8 – penta CDF	0.5
2,3,7,8 – hexa CDFs	0.1
2,3,7,8 – hepta CDFs	0.01
Octa CDF	0.001

Consistent with 40 CFR 122.44(l)(2)(i)(B), effluent limitations from Order No. R9-2006-002 are not retained for constituents for which the RPA results indicated Endpoint 2. Instead performance goals have been assigned for these constituents. Parameters for which Endpoint 2 was concluded are determined not to have reasonable potential, thus it is inappropriate to establish or retain effluent limitations for these parameters.

For parameters for which Endpoint 3 was concluded, the reasonable potential analysis was inconclusive. For parameters for which Endpoint 3 was concluded and previous effluent limitations had not been established, reasonable potential was not determined. For parameters for which new data is available, and the reasonable potential analysis results are inconclusive, effluent limitations have been retained. During the current permit reissuance, none of the parameters for which effluent limitations had been established in the previous Order were determined to be Endpoint 3.

Reasonable potential to cause or contribute to an exceedance of water quality objectives contained within the Ocean Plan (i.e. Endpoint 1) was determined for TCDD equivalents and total residual chlorine, thus effluent limitations for TCDD equivalents and total residual chlorine have been established in this Order based on the initial dilution of 87 to 1, as discussed below.

The monitoring and reporting program (MRP) in Attachment E of this Order is designed to obtain additional information for these constituents to determine if reasonable potential exists for these constituents in future permit renewals and/or updates.

4. WQBEL Calculations

- a. From the Table B water quality objectives of the Ocean Plan, effluent limitations and performance goals are calculated according to the following equation for all pollutants, except for acute toxicity (if applicable) and radioactivity:

$$C_e = C_o + D_m (C_o - C_s) \text{ where,}$$

C_e = the effluent limitation ($\mu\text{g/L}$)

C_o = the water quality objective to be met at the completion of initial dilution ($\mu\text{g/L}$)

C_s = background seawater concentration

D_m = minimum probable initial dilution expressed as parts seawater per part wastewater

- b. Initial dilution (D_m) has been determined to be 87 to 1 by the San Diego Water Board through the application of USEPA's dilution model, Visual Plumes.
- c. Table C of the Ocean Plan establishes background concentrations for some pollutants to be used when determining reasonable potential (represented as " C_s "). In accordance with Table B implementing procedures, C_s equals zero for

all pollutants not established in Table C. The background concentrations provided in Table C are summarized below:

Table F-10. Pollutants Having Background Concentrations

Pollutant	Background Seawater Concentration
Arsenic	3 µg/L
Copper	2 µg/L
Mercury	0.0005 µg/L
Silver	0.16 µg/L
Zinc	8 µg/L

- d. As an example of how effluent limitations and performance goals have been calculated, the performance goals for cyanide are determined as follows:

Water quality objectives from the Ocean Plan for cyanide are:

Table F-11. Example Parameter Water Quality Objectives

Parameter	Units	6-Month Median	Daily Maximum	Instantaneous Maximum
Cyanide	µg/L	1	4	10

Using the equation, $C_e = C_o + D_m (C_o - C_s)$, effluent limitations/performance goals are calculated as follows.

Cyanide

$$C_e = 1 + 87 (1 - 0) = 88 \text{ (6-Month Median)}$$

$$C_e = 4 + 87 (4 - 0) = 352 \text{ (Daily Maximum)}$$

$$C_e = 10 + 87 (10 - 0) = 880 \text{ (Instantaneous Maximum)}$$

Based on the implementing procedures described above, effluent limitations and performance goals have been calculated for all Table B pollutants from the Ocean Plan and incorporated into this Order.

- e. 40 CFR 122.45(f)(1) requires effluent limitations be expressed in terms of mass, with some exceptions, and 40 CFR 122.45(f)(2) allows pollutants that are limited in terms of mass to additionally be limited in terms of other units of measurement. This Order includes effluent limitations expressed in terms of mass and concentration. In addition, pursuant to the exceptions to mass limitations provided in 40 CFR 122.45(f)(1), some effluent limitations are not expressed in terms of mass, such as pH and temperature, and when the applicable standards are expressed in terms of concentration (e.g., CTR criteria and MCLs) and mass limitations are not necessary to protect the beneficial uses of the receiving water.

Mass-based effluent limitations were calculated using the following equation:

$$\text{lbs/day} = \text{permitted flow (MGD)} \times \text{pollutant concentration (mg/L)} \times 8.34$$

f. A summary of the WQBELs established in this Order are provided below:

Table F-12. Summary of Water Quality-based Effluent Limitations – Discharge Point No. 001

Parameter	Unit	Effluent Limitations ¹			
		6-Month Median	Maximum Daily	Instantaneous Maximum	Average Monthly
OBJECTIVES FOR PROTECTION OF MARINE AQUATIC LIFE					
Total Residual Chlorine ²	µg/L	180	700	5,300	--
	lbs/day	4.0	16	120	--
OBJECTIVES FOR PROTECTION OF HUMAN HEALTH – CARCINOGENS					
TCDD ³	µg/L	--	--	--	3.4E-07
	lbs/day	--	--	--	7.7E-09

¹ Scientific “E” notation is used to express effluent limitations. In scientific “E” notation, the number following the “E” indicates that position of the decimal point in the value. Negative numbers after the “E” indicate that the value is less than 1, and positive numbers after the “E” indicate that the value is greater than 1. In this notation a value of 6.1E-02 represents 6.1×10^{-2} or 0.061, 6.1E+02 represents 6.1×10^2 or 610, and 6.1E+00 represents 6.1×10^0 or 6.1.

² The water quality objectives for total chlorine residual applicable to intermittent discharges not exceeding two hours shall be determined through use of the following equation:

$$\log y = 0.43(\log x) + 1.8$$

where,

y = the water quality objective (in µg/L) to apply when chlorine is being discharged;

x = the duration of uninterrupted chlorine discharge in minutes.

Actual effluent limitations for total chlorine, when discharging intermittently, shall then be determined according to Implementation Procedures for Table B from the Ocean Plan and using a minimum probable dilution factor of 87 and a flow rate of 2.7 MGD.

³ TCDD equivalents represent the sum of concentrations of chlorinated dibenzodioxins (2,3,7,8-CDDs) and chlorinated dibenzofurans (2,3,7,8-CDFs) multiplied by their respective toxicity factors.

g. A summary of the performance goals is provided in Table F-14 of this Fact Sheet.

5. Whole Effluent Toxicity (WET)

a. Implementing provisions at section III.C.4.c.(4) of the Ocean Plan require chronic toxicity monitoring for ocean waste discharges with minimum initial dilution factors that fall below 100:1 at the edge of the mixing zone. Using quarterly chronic WET testing conducted between January 2005 and November 2006 to conduct the RPA, resulted in Endpoint 2, and an effluent limitation for chronic toxicity is not required. However, consistent with Order No. R9-2006-002, this Order contains a performance goal and quarterly monitoring for chronic toxicity. Based on the methods established by the Ocean Plan, a maximum daily performance goal of 88 TUC is established in this Order.

b. Implementing provisions at section III.C.4.c.(3) of the Ocean Plan states that the San Diego Water Board may require acute toxicity testing in addition to chronic toxicity monitoring for ocean waste discharges with minimum initial dilution factors ranging from 100:1 to 350:1 as necessary for the protection of beneficial

uses of ocean waters. The Oceanside OO has been granted a dilution ratio of 87:1 and the results of the RPA do not indicate reasonable potential for acute toxicity, thus monitoring for acute toxicity is not necessary and has been discontinued.

D. Final Effluent Limitations

1. Final Effluent Limitations

The following tables list the effluent limitations established by this Order. Where this Order establishes mass emission limitations, these limitations have been derived based on a flow of 2.7 MGD.

Table F-13.a. Technology Based Effluent Limitations at M-001

Parameter	Units	Effluent Limitations					
		Average Monthly	Average Weekly	Maximum Daily	Instantaneous Minimum	Instantaneous Maximum	6-Month Median
Carbonaceous Biochemical Oxygen Demand (5-day @ 20°C) ¹	mg/L	25	40	--	--	--	--
	lbs/day	560	900	--	--	--	--
Total Suspended Solids ¹	mg/L	30	45	--	--	--	--
	lbs/day	680	1,000	--	--	--	--
Oil and Grease	mg/L	25	40	--	--	75	--
	lbs/day	560	900	--	--	1,700	--
Settleable Solids	ml/L	1.0	1.5	--	--	3.0	--
Turbidity	NTU	75	100	--	--	225	--
pH	standard units	--	--	--	6.0	9.0	--

¹ The average monthly percent removal of CBOD₅ and TSS shall not be less than 85 percent.

Table F-13.b. Effluent Limitations Based on Table B of the Ocean Plan at M-001 or M-002 (Discharge Point No. 001)

Parameter	Unit	Effluent Limitations ¹			
		6-Month Median	Maximum Daily	Instantaneous Maximum	Average Monthly
OBJECTIVES FOR PROTECTION OF MARINE AQUATIC LIFE					
Total Residual Chlorine ²	µg/L	180	700	5,300	--
	lbs/day	4.0	16	120	--
OBJECTIVES FOR PROTECTION OF HUMAN HEALTH – CARCINOGENS					
TCDD ³	µg/L	--	--	--	3.4E-07
	lbs/day	--	--	--	7.7E-09

¹ Scientific “E” notation is used to express effluent limitations. In scientific “E” notation, the number following the “E” indicates that position of the decimal point in the value. Negative numbers after the “E” indicate that the value is less than 1, and positive numbers after the “E” indicate that the value is greater than 1. In this notation a value of 6.1E-02 represents 6.1×10^{-2} or 0.061, 6.1E+02 represents 6.1×10^2 or 610, and 6.1E+00 represents 6.1×10^0 or 6.1.

² The water quality objectives for total chlorine residual applicable to intermittent discharges not exceeding two hours shall be determined through use of the following equation:

$$\log y = 0.43(\log x) + 1.8$$

where,

y = the water quality objective (in µg/L) to apply when chlorine is being discharged;

x = the duration of uninterrupted chlorine discharge in minutes.

Actual effluent limitations for total chlorine, when discharging intermittently, shall then be determined according to Implementation Procedures for Table B from the Ocean Plan and using a minimum probable dilution factor of 87 and a flow rate of 2.7 MGD.

³ TCDD equivalents represent the sum of concentrations of chlorinated dibenzodioxins (2,3,7,8-CDDs) and chlorinated dibenzofurans (2,3,7,8-CDFs) multiplied by their respective toxicity factors.

2. Satisfaction of Anti-Backsliding Requirements

The technology based effluent limitations in this Order are at least as stringent as the effluent limitations in the previous Order.

Effluent limitations from Order No. R9-2006-002 are not retained for constituents for which RPA results indicated Endpoint 2, or Endpoint 3 when previous effluent limitations had not been established; instead performance goals have been assigned for these constituents. Parameters for which Endpoint 2 was concluded are determined not to have reasonable potential, thus it is inappropriate to establish effluent limitations for these parameters. For parameters for which Endpoint 3 was concluded and previous effluent limitations had not been established, reasonable potential was not determined. For parameters for which new data is available, and a reasonable potential analysis determined that reasonable potential does not exist, effluent limitations have been removed as allowed under 40 CFR 122(l)(2)(i)(B), and performance goals have been established in their place. The MRP for this Order is designed to obtain additional information for these constituents to determine if reasonable potential exists for these constituents in future permit renewals and/or updates.

This permit complies with all applicable federal and State anti-backsliding regulations.

3. Satisfaction of Antidegradation Policy

WDRs for FPUD must conform with federal and State antidegradation policies provided at 40 CFR 131.12 and in State Water Board Resolution No. 68-16, *Statement of Policy with Respect to Maintaining High Quality of Waters in California*. The antidegradation policies require that beneficial uses and the water quality necessary to maintain those beneficial uses in the receiving waters of the discharge shall be maintained and protected, and, if existing water quality is better than the quality required to maintain beneficial uses, the existing water quality shall be maintained and protected unless allowing a lowering of water quality is necessary to accommodate important economic and social development or consistent with maximum benefit to the people of California. When a significant lowering of water quality is allowed by the San Diego Water Board, an antidegradation analysis is required in accordance with the State Water Board's Administrative Procedures Update (July 2, 1990), *Antidegradation Policy Implementation for NPDES Permitting*.

a. Technology-based Effluent Limitations

The TBELs are at least as stringent as the previous effluent limitations, and no degradation of the receiving water is expected.

b. Water Quality-based Effluent Limitations

The WQBELs contained in this Order have been modified from previous NPDES permits for FPUD, including Order No. R9-2006-002, to remove effluent limitations for some parameters after an RPA was conducted. In accordance with the State Water Board's Administrative Procedures Update (APU) No. 90-004, the San Diego Water Board assessed the potential impact of the modified effluent limitations on existing water quality and the need for an antidegradation analysis.

Effluent limitations were not included in this Order for constituents which reasonable potential to exceed the water quality objectives was not indicated following an RPA although the previous permit included effluent limitations for those constituents. The procedures for conducting the RPA are explained in section IV.C.3 of this Fact Sheet. For constituents for which effluent limitations were not included, performance goals were included which will indicate the level of discharge at which possible water quality impacts may be significant. The removal of effluent limitations by itself is not expected to cause a change in the physical nature of the effluent discharged and is not expected to impact beneficial uses nor cause a reduction of the water quality of the receiving water. Coupled with the inclusion of performance goals and retention of the monitoring program for constituents without effluent limitations, the existing water quality is expected to be maintained. For these reasons, the San Diego Water Board has determined that an antidegradation analysis is not required to consider the possible impacts resulting from the removal of effluent limitations following a RPA.

4. Stringency of Requirements for Individual Pollutants

This Order contains both TBELs and WQBELs for individual pollutants. The TBELs consist of restrictions on CBOD₅, TSS, oil and grease, settleable solids, turbidity, and pH. Restrictions on these constituents are discussed in section IV.B of this Fact Sheet. This Order's technology-based pollutant restrictions implement the minimum, applicable federal technology-based requirements. These limitations are not more stringent than required by the CWA.

WQBELs have been scientifically derived to implement water quality objectives that protect beneficial uses. Both the beneficial uses and the water quality objectives have been approved pursuant to federal law and are the applicable federal water quality standards. The scientific procedures for calculating the individual WQBELs are based on the Ocean Plan, which was approved by USEPA on February 14, 2006. All beneficial uses and water quality objectives contained in the Basin Plan were approved under State law and submitted to and approved by USEPA prior to May 30, 2000. Any water quality objectives and beneficial uses submitted to USEPA prior to May 30, 2000, but not approved by USEPA before that date, are nonetheless "applicable water quality standards for purposes of the CWA" pursuant to 40 CFR 131.21(c)(1). Collectively, this Order's restrictions on individual pollutants are no more stringent than required to implement the requirements of the CWA.

E. Performance Goals

Constituents that do not have reasonable potential are listed as performance goals in this Order. Performance goals serve to maintain existing treatment levels and effluent quality and supports State and federal antidegradation policies. Additionally, performance goals provide all interested parties with information regarding the expected levels of pollutants in the discharge that should not be exceeded in order to maintain the water quality objectives established in the Ocean Plan. Performance goals are not effluent limitations or standards as defined by the Clean Water Act for the regulation of the discharge. Effluent concentrations above the performance goals will not be considered as violations of the permit but serve as red flags that indicate the potential for water quality concerns. Repeated red flags may prompt the San Diego Water Board to reopen and amend the permit to replace performance goals for constituents of concern with effluent limitations or the San Diego Water Board may coordinate such actions with the next permit renewal.

The following table lists the performance goals established by this Order. A minimum probable initial dilution factor of 87:1 was used in establishing the performance goals.

Table F-14. Performance Goals Based on the Ocean Plan

Parameter	Unit	Performance Goals ¹			
		6-Month Median	Maximum Daily	Instantaneous Maximum	30-Day Average
OBJECTIVES FOR PROTECTION OF MARINE AQUATIC LIFE					
Arsenic, Total Recoverable	µg/L	4.4E+02	2.6E+03	6.8E+03	--
Cadmium, Total Recoverable	µg/L	8.8E+01	3.5E+02	8.8E+02	--
Chromium VI, Total Recoverable ²	µg/L	1.8E+02	7.0E+02	1.8E+03	--
Copper, Total Recoverable	µg/L	9.0E+01	8.8E+02	2.5E+03	--
Lead, Total Recoverable	µg/L	1.8E+02	7.0E+02	1.8E+03	--
Mercury, Total Recoverable	µg/L	3.09E+00	1.4E+01	3.5E+01	--
Nickel, Total Recoverable	µg/L	4.4E+02	1.8E+03	4.4E+03	--
Selenium, Total Recoverable	µg/L	1.3E+03	5.3E+03	1.3E+04	--
Silver, Total Recoverable	µg/L	4.8E+01	2.3E+02	6.0E+02	--
Zinc, Total Recoverable	µg/L	1.1E+03	6.3E+03	1.7E+04	--
Cyanide, Total Recoverable	µg/L	8.8E+01	3.5E+02	8.8E+02	
Ammonia (expressed as nitrogen)	µg/L	5.3E+04	2.1E+05	5.3E+05	--
Acute Toxicity	TUa	--	2.9E+00	--	
Chronic Toxicity ³	TUc	--	8.8E+01	--	--
Phenolic Compounds (non-chlorinated) ⁴	µg/L	2.6E+03	1.1E+04	2.6E+04	--
Chlorinated Phenolics ⁵	µg/L	8.8E+01	3.5E+02	8.8E+02	--
Endosulfan ⁶	µg/L	7.9E-01	1.6E+00	2.4E+00	--
Endrin	µg/L	1.8E-01	3.5E-01	5.3E-01	--
HCH ⁷	µg/L	3.5E-01	7.0E-01	1.1E+00	--
Radioactivity	pCi/L	Not to exceed limits specified in Title 17, Division 1, Chapter 5, Subchapter 4, Group 3, Article 3, Section 30253 of the California Code of Regulations, Reference to Section 30253 is prospective, including future changes to any incorporated provisions of federal law, as the changes take effect.			

OBJECTIVES FOR PROTECTION OF HUMAN HEALTH – NONCARCINOGENS					
Acrolein	µg/L	--	--	--	1.9E+04
Antimony	µg/L	--	--	--	1.1E+05
Bis(2-chloroethoxy) Methane	µg/L	--	--	--	3.9E+02
Bis(2-chloroisopropyl) Ether	µg/L	--	--	--	1.1E+05
Chlorobenzene	µg/L	--	--	--	5.0E+04
Chromium (III), Total Recoverable	µg/L	--	--	--	1.7E+07
Di-n-butyl Phthalate	µg/L	--	--	--	3.1E+05
Dichlorobenzenes ⁸	µg/L	--	--	--	4.5E+05
Diethyl Phthalate	µg/L	--	--	--	2.9E+06
Dimethyl Phthalate	µg/L	--	--	--	7.2E+07
4,6-dinitro-2-methylphenol	µg/L	--	--	--	1.9E+04
2,4-dinitrophenol	µg/L	--	--	--	3.5E+02
Ethylbenzene	µg/L	--	--	--	3.6E+05
Fluoranthene	µg/L	--	--	--	1.3E+03
Hexachlorocyclopentadiene	µg/L	--	--	--	5.1E+03
Nitrobenzene	µg/L	--	--	--	4.3E+02
Thallium, Total Recoverable	µg/L	--	--	--	1.8E+02
Toluene	µg/L	--	--	--	7.5E+06
Tributyltin	µg/L	--	--	--	1.2E-01
1,1,1-trichloroethane	µg/L	--	--	--	4.8E+07
OBJECTIVES FOR PROTECTION OF HUMAN HEALTH – CARCINOGENS					
Acrylonitrile	µg/L	--	--	--	8.8E+00
Aldrin	µg/L	--	--	--	1.9E-03
Benzene	µg/L	--	--	--	5.2E+02
Benzidine	µg/L	--	--	--	6.1E-03
Beryllium	µg/L	--	--	--	2.9E+00
Bis(2-chloroethyl) Ether	µg/L	--	--	--	4.0E+00
Bis(2-ethylhexyl) Phthalate	µg/L	--	--	--	3.1E+02
Carbon Tetrachloride	µg/L	--	--	--	7.9E+01
Chlorodane	µg/L	--	--	--	2.0E-03
Chlorodibromomethane	µg/L	--	--	--	7.6E+02
Chloroform	µg/L	--	--	--	1.1E+04
DDT ⁹	µg/L	--	--	--	1.5E-02
1,4-dichlorobenzene	µg/L	--	--	--	1.6E+03
3,3'-dichlorobenzidine	µg/L	--	--	--	7.1E-01
1,2-dichloroethane	µg/L	--	--	--	2.5E+03
1,1-dichloroethylene	µg/L	--	--	--	7.9E+01
Dichlorobromomethane	µg/L	--	--	--	5.5E+02
Dichloromethane	µg/L	--	--	--	4.0E+04
1,3-dichloropropene	µg/L	--	--	--	7.8E+02
Dieldrin	µg/L	--	--	--	3.5E-03
2,4-dinitrotoluene	µg/L	--	--	--	2.3E+02

1,2-diphenylhydrazine	µg/L	--	--	--	1.4E+01
Halomethanes ¹⁰	µg/L	--	--	--	1.1E+04
Heptachlor	µg/L	--	--	--	4.4E-03
Heptachlor Epoxide	µg/L	--	--	--	1.8E-03
Hexachlorobenzene	µg/L	--	--	--	1.8E-02
Hexachlorobutadiene	µg/L	--	--	--	1.2E+03
Hexachloroethane	µg/L	--	--	--	2.2E+02
Isophorone	µg/L	--	--	--	6.4E+04
N-nitrosodimethylamine	µg/L	--	--	--	6.4E+02
N-nitrosodi-N-propylamine	µg/L	--	--	--	3.3E+01
N-nitrosodiphenylamine	µg/L	--	--	--	2.2E+02
PAHs ¹¹	µg/L	--	--	--	7.7E-01
PCBs ¹²	µg/L	--	--	--	1.7E-03
1,1,2,2-tetrachloroethane	µg/L	--	--	--	2.0E+02
Tetrachloroethylene	µg/L	--	--	--	1.8E+02
Toxaphene	µg/L	--	--	--	1.8E-02
Trichloroethylene	µg/L	--	--	--	2.4E+03
1,1,2-trichloroethane	µg/L	--	--	--	8.3E+02
2,4,6-trichlorophenol	µg/L	--	--	--	2.6E+01
Vinyl Chloride	µg/L	--	--	--	3.2E+03

¹ Scientific "E" notation is used to express certain values. In scientific "E" notation, the number following the "E" indicates that position of the decimal point in the value. Negative numbers after the "E" indicate that the value is less than 1, and positive numbers after the "E" indicate that the value is greater than 1. In this notation a value of 6.1E-02 represents 6.1×10^{-2} or 0.061, 6.1E+02 represents 6.1×10^2 or 610, and 6.1E+00 represents 6.1×10^0 or 6.1.

² Dischargers may, at their option, apply this performance goal as a total chromium performance goal.

³ Chronic toxicity expressed as Chronic Toxicity Units (TUc) = 100/NOEL, where NOEL (No Observed Effect Level) is expressed as the maximum percent effluent or receiving water that causes no observable effect on a test organism.

⁴ Non-chlorinated phenolic compounds represent the sum of 2,4-dimethylphenol, 4,6-Dinitro-2-methylphenol, 2,4-dinitrophenol, 2-methylphenol, 4-methylphenol, 2-Nitrophenol, 4-nitrophenol, and phenol.

⁵ Chlorinated phenolic compounds represent the sum of 4-chloro-3-methylphenol, 2-chlorophenol, pentachlorophenol, 2,4,5-trichlorophenol, and 2,4,6-trichlorophenol.

⁶ Endosulfan represents the sum of alpha-endosulfan, beta-endosulfan, and endosulfan sulfate.

⁷ HCH (hexachlorocyclohexane) represents the sum of the alpha, beta, gamma (Lindane), and delta isomers of hexachlorocyclohexane.

⁸ Dichlorobenzenes represent the sum of 1,2- and 1,3-dichlorobenzene.

⁹ DDT represents the sum of 4,4'DDT; 2,4'DDT; 4,4'DDE; 2,4'DDE; 4,4'DDD; and 2,4'DDD.

¹⁰ Halomethanes represent the sum of bromoform, bromomethane (methyl bromide), and chloromethane (methyl chloride).

¹¹ PAHs (polynuclear aromatic hydrocarbons) represent the sum of acenaphthalene; anthracene; 1,2-benzanthracene; 3,4-benzofluoranthene; benzo[k]fluoranthene; 1,12-benzoperylene; benzo[a]pyrene; chrysene; dibenzo[a,h]anthracene; fluorene; indeno[1,2,3-cd]pyrene; phenanthrene; and pyrene.

¹² PCBs (polychlorinated biphenyls) represent the sum of chlorinated biphenyls whose analytical characteristics resemble those of Aroclor-1016, Aroclor-1221, Aroclor-1232, Aroclor-1242, Aroclor-1248, Aroclor-1254, and Aroclor-1260.

F. Interim Effluent Limitations

Order No. R9-2012-0005 supplements the requirements of Order No. R9-2012-0004 and establishes a Time Schedule for FPUD to comply with the final total residual chlorine effluent limitations prescribed in Order No. R9-2012-0004 (NPDES Permit NO. CA0108031). Order No. R9-2012-0005 includes the following interim effluent limitation¹ for total residual chlorine at Monitoring Location M-001 or M-002, as described in Order No. R9-2012-0004, to be effective until **March 31, 2016** or when the Discharger achieves compliance, whichever is earlier:

Table 2: Interim Total Residual Chlorine Effluent Limitations

Parameter	Unit	Effluent Limitations			
		6-Month Median	Maximum Daily	Instantaneous Maximum	Average Monthly
Total Residual Chlorine	mg/L	5.4	11.12	11.12	
	lbs/day	122	252	252	

G. Land Discharge Specifications – Not Applicable

H. Reclamation Specifications

FPUD must continue to comply with the separate reclamation requirements established in San Diego Water Board Order No. 91-39 and any applicable future revised or renewal waste discharge requirements, which are not incorporated by reference into this Permit.

V. RATIONALE FOR RECEIVING WATER LIMITATIONS

Receiving water limitations of this Order are derived from the water quality objectives for ocean waters established by the Basin Plan and the Ocean Plan.

The water contact bacterial standards in the previous Order No. R9-2006-002, which were based on the language in the 2001 Ocean Plan, have changed. The language in the 2009 Ocean Plan now specifies that the Water-Contact Standards apply to ocean waters within California's jurisdiction designated by the San Diego Water Board as having REC-1 beneficial uses. Because the San Diego Water Board has not completed a process to designate specific areas where the water-contact standards apply, Ocean Plan Bacterial Standards apply throughout all ocean waters in the San Diego Region. Thus, the applicable standards are included in this Order. See section VII.B.7 of this Fact Sheet for additional information on compliance with the 2009 Ocean Plan bacterial standards.

VI. RATIONALE FOR MONITORING AND REPORTING REQUIREMENTS

40 CFR 122.48 requires that all NPDES permits specify requirements for recording and reporting monitoring results. CWC sections 13267 and 13383 authorize the San Diego

¹ The interim effluent limitations are based on effluent performance data from July 1, 2012 through July 31, 2011 for the Discharger where 99.9% of the data points lie within 3.3 standard deviations of the mean.

Water Board to require technical and monitoring reports. The MRP (Attachment E of this Order), establishes monitoring and reporting requirements to implement federal and State requirements. The following provides the rationale for the monitoring and reporting requirements contained in the MRP for this Facility.

A. Influent Monitoring

Influent monitoring is required to determine the effectiveness of the source control program, to assess the performance of treatment facilities, and to evaluate compliance with effluent limitations. Influent monitoring frequencies and sample types for flow, CBOD₅, and TSS have been retained from Order No. R9-2006-002. Refer to section III.A of Attachment E of this Order for a summary of influent monitoring requirements.

B. Effluent Monitoring

Effluent monitoring is required to determine compliance with the permit conditions and to identify operational problems and improve plant performance. Effluent monitoring also provides information on wastewater characteristics and flows for use in interpreting water quality and biological data. Effluent monitoring requirements for most of the parameters have been retained from Order No. R9-2006-002. Effluent monitoring for TCDD equivalents have been increased from annually to semiannually based on the results of the RPA and to determine compliance with the newly established effluent limitations. Order No. R9-2006-002 gave FPUD the option of sampling for parameters contained in Table B of the Ocean Plan at either Monitoring Location M-001 (located at the end of the Facility treatment train) or at Monitoring Location M-002 (located near the terminus of the Fallbrook Land Outfall prior to joining the Oceanside OO). This option permits FPUD reasonable flexibility in their sampling regimen (i.e., sampling for whole effluent toxicity and total residual chlorine may be conducted at M-002) and has been retained.

C. Whole Effluent Toxicity Testing Requirements

As described in section IV.C.5 of this Fact Sheet, quarterly chronic WET testing is required by this Order to evaluate compliance with Table B water quality objective and evaluate any potential synergistic effects associated with pollutants in the effluent.

D. Receiving Water Monitoring

1. Surface Water

a. Microbiological (Near Shore and Off Shore)

The near shore and off shore water quality sampling program is designed to help evaluate the fate of the wastewater plume under various conditions and to determine if the Ocean Plan standards are being negatively impacted by the discharge. Further, bacterial sampling is required to provide data to help track the wastewater plume in the offshore waters, to evaluate compliance with recreational water standards in the kelp beds, and to address issues of beach water quality at the shoreline stations. Monitoring requirements for total coliform organisms, fecal coliform organisms, and enterococcus bacteria have been

established in this Order, consistent with Order No. R9-2006-002 and consistent with the City of Oceanside's Order No. R9-2011-0016.

b. Benthic Monitoring

Sediment and infauna monitoring is required to help evaluate the potential effects of the discharge on the physical and chemical properties of the sediment and biological communities in the vicinity of the discharge, consistent with Order No. R9-2006-002.

c. Fish and Invertebrate

Fish and invertebrate monitoring is required to assess the effects of the discharge on local fish and megabenthic invertebrate communities in the surrounding area of the discharge location, consistent with Order No. R9-2006-002.

E. Other Monitoring Requirements

- 1. Kelp Bed Monitoring.** Kelp bed monitoring is intended to assess the extent to which the discharge of wastes may affect the aerial extent and health of coastal kelp beds. The aerial extent of the various kelp beds photographed in each survey will provide a baseline for future monitoring to help evaluate any significant and persistent losses to the kelp beds.
- 2. Regional Monitoring.** The purpose of regional monitoring programs (such as the Southern California Bight Regional Monitoring Program, which is coordinated by the Southern California Coastal Water Research Project) is to address questions about conditions in and influences on water bodies with regard to beneficial uses. This is done using scientifically sound and cost-effective monitoring designs and coordinating the efforts of various parties involved in monitoring. The Discharger is required to participate in regional monitoring programs pursuant to 40 CFR 122.48 and CWC sections 13225, 13267, and 13383.

FPUD may request to reduce the level of effort devoted to other monitoring so that resources can be reallocated to regional monitoring by submitting a proposal to the San Diego Water Board and USEPA for such changes (including sampling, analytical, and/or reporting work).

- 3. Solids Monitoring.** FPUD is required to monitor solids generated at the Facility pursuant to 40 CFR Part 503. FPUD shall report, annually, the volume of screenings, sludges, grit, and other solids generated and/or removed during wastewater treatment and the locations where these waste materials are placed for disposal.

VII. RATIONALE FOR PROVISIONS

A. Standard Provisions

Standard Provisions, which apply to all NPDES permits in accordance with 40 CFR 122.41, and additional conditions applicable to specified categories of permits in accordance with 40 CFR 122.42, are provided in Attachment D to the Order.

40 CFR 122.41(a)(1) and (b) through (n) establish conditions that apply to all State-issued NPDES permits. These conditions must be incorporated into the permits either expressly or by reference. If incorporated by reference, a specific citation to the regulations must be included in the Order. 40 CFR 123.25(a)(12) allows the State to omit or modify conditions to impose more stringent requirements. In accordance with 40 CFR 123.25, this Order omits federal conditions that address enforcement authority specified in 40 CFR 122.41(j)(5) and (k)(2) because the enforcement authority under the CWC is more stringent. In lieu of these conditions, this Order incorporates by reference CWC section 13387(e).

B. Special Provisions

1. Reopener Provisions

This Order may be re-opened and modified, revoked, and reissued or terminated in accordance with the provisions of 40 CFR Parts 122, 123, 124, and 125. The San Diego Water Board may reopen the permit to modify permit conditions and requirements [including, but not limited to, increased/ modified receiving water requirements and participation in the Southern California Coastal Water Research Project (SCCWRP) model monitoring program]. Causes for modifications include the promulgation of new regulations, modification in sludge use or disposal practices, or adoption of new regulations by the State Water Board or San Diego Water Board, including revisions to the Basin Plan.

2. Special Studies and Additional Monitoring Requirements

a. Spill Prevention and Response Plans

The CWA largely prohibits any discharge of pollutants from point sources to waters of the United States except as authorized under an NPDES permit. In general, any point source discharge of sewage effluent to waters of the United States must comply with technology-based, secondary treatment standards, at a minimum, and any more stringent requirements necessary to meet applicable water quality standards and other requirements. The unpermitted discharge of wastewater to waters of the United States is illegal under the CWA. Further, the Basin Plan prohibits discharges of waste to land, except as authorized by WDRs of the terms described in CWC section 13264. The Basin Plan also prohibits the unauthorized discharge of treated or untreated sewage to waters of the State or to a storm water conveyance system. Further, Discharge Prohibition III.A of the Order prohibits the discharge of waste from the Facility not treated by secondary treatment process and not in compliance with the effluent limitations of the Order and/or to a location other than Discharge Point No. 001.

Sanitary collection and treatment systems experience periodic failures resulting in discharges that may affect waters of the State. There are many factors which may affect the likelihood of a spill. To ensure appropriate funding, management and planning to reduce the likelihood of a spill, and increase the spill preparedness, this Order requires FPUD to maintain and implement Spill Prevention and Response Plans.

b. Spill Reporting Requirements.

To determine compliance with Discharge Prohibition III.A and provide appropriate notification to the general public for the protection of public health, spill reporting requirements have been established in section VI.C.2.b of this Order.

c. Whole Effluent Toxicity (WET)

Implementing provisions at section III.C.4.c.(4) of the Ocean Plan require chronic toxicity monitoring for ocean waste discharges with minimum initial dilution of less than 100:1. Based on methods of the Ocean Plan, a maximum daily performance goal of 88 TUc is established in this Order and quarterly monitoring is retained from Order No. R9-2006-002.

As described further in section IV.C.5.b of this Fact Sheet, this Order does not require acute toxicity testing.

This Order requires FPUD to update, as necessary, its Toxicity Reduction Evaluation (TRE) workplan, and submit any revisions of the TRE workplan within 180 days of the effective date of this Order. The workplan shall describe steps FPUD intends to follow if the performance goal for chronic toxicity (88 TUc) is exceeded.

If the performance goal for chronic toxicity is exceeded in any one test, then within 15 days of the exceedance, FPUD shall begin conducting six additional tests, bi-weekly, over a 12 week period. If the toxicity performance goal is exceeded in any of these six additional tests, then FPUD shall notify the San Diego Water Board and Director. If the San Diego Water Board and Director determine that the discharge consistently exceeds a toxicity performance goal, then FPUD shall initiate a TRE/TIE in accordance with the TRE workplan, *Toxicity Reduction Evaluation Guidance for Municipal Wastewater Treatment Plants* (USEPA 833-B-99-002, 1999), and USEPA Toxicity Identification Evaluation (TIE) guidance documents (Phase I, EPA/600/6-91/005F, 1992; Phase II, EPA/600/R-92/080, 1993; and Phase III, EPA/600/R-92/081, 1993). Once the source of toxicity is identified, FPUD shall take all reasonable steps to reduce the toxicity to meet the chronic toxicity performance goal identified in section IV.A.2 of this Order.

Within 30 days of completion of the TRE/TIE, FPUD shall submit the results of the TRE/TIE, including a summary of the findings, data generated, a list of corrective actions necessary to achieve consistent compliance with all the toxicity limitations/performance goals of this Order and prevent recurrence of exceedances of those limitations/performance goals, and a time schedule for

implementation of such corrective actions. The corrective actions and time schedule shall be modified at the direction of the San Diego Water Board.

If no toxicity is detected in any of these additional six tests, then FPUD may return to the testing frequency specified in the MRP.

- 3. Best Management Practices and Pollution Prevention – Not Applicable**
- 4. Construction, Operation, and Maintenance Specifications – Not Applicable**
- 5. Special Provisions for Wastewater Facilities**

- a. Treatment Plant Capacity**

Consistent with Order No. R9-2006-002, this Order requires FPUD to perform a treatment plant capacity study to serve as an indicator for the San Diego Water Board of the Facility's increasing hydraulic capacity and growth in the service area.

FPUD shall submit a written report to the San Diego Water Board within 90 days after the monthly average influent flow rate equals or exceeds 75 percent of the secondary treatment design capacity of the wastewater treatment and/or disposal facilities. FPUD's senior administrative officer shall sign a letter in accordance with Standard Provision V.B. (Attachment D of this Order) which transmits that report and certifies that that policy-making body is adequately informed of the influent flow rate relative to the Facility's design capacity. The report shall include the following:

- Average influent daily flow for the calendar month, the date on which the maximum daily flow occurred, and the rate of that maximum flow.
- FPUD's best estimate of when the average daily influent flow for a calendar month will equal or exceed the design capacity of the facilities.
- FPUD's intended schedule for studies, design, and other steps needed to provide additional treatment for the wastewater from the collection system and/or control the flow rate before the waste flow exceeds the capacity of present units.

- b. Pretreatment Program**

Because the Facility does not currently receive discharges from industries that are subject to USEPA's pretreatment standards, FPUD is not currently required to develop and implement an industrial pretreatment program. Consistent with Order No. R9-2006-002, this Order requires FPUD to perform an Industrial Waste Survey (IWS) and influent priority pollutant monitoring to determine whether a pretreatment program is required pursuant to 40 CFR Part 403.

- c. Biosolids**

The use and disposal of biosolids is regulated under federal and State laws and regulations, including permitting requirements and technical standards included in 40 CFR Part 503. FPUD is required to comply with the standards and time schedules contained in 40 CFR Part 503.

Title 27, CCR, Division 2, Subdivision 1, section 20005 establishes approved methods for the disposal of collected screenings, residual sludge, biosolids, and other solids removed from liquid wastes. Requirements to ensure FPUD disposes of solids in compliance with State and federal regulations have been included in this Order.

d. Collection System

The State Water Board issued General Waste Discharge Requirements for Sanitary Sewer Systems, Water Quality Order No. 2006-0003-DWQ (General Order) on May 2, 2006, which is not incorporated herein by reference. The General Order requires public agencies that own or operate sanitary sewer systems with greater than 1 mile of pipes or sewer lines to enroll for coverage under the General Order. The General Order requires agencies to develop sanitary sewer management plans (SSMPs) and report all sanitary sewer overflows (SSOs), among other requirements and prohibitions.

Furthermore, the General Order contains requirements for operation and maintenance of collection systems and for reporting and mitigating SSOs. Public agencies that are discharging wastewater into the Facility were required to obtain enrollment for regulation under the General Order by December 1, 2006.

6. Other Special Provisions – Not Applicable

7. Compliance Schedules

FPUD currently disinfects Facility effluent with chlorine to meet State Health requirements for recycled water. Prior to terminating disinfection of their effluent, FPUD must submit a plan and time schedule that outlines the tasks and approaches to achieve full compliance with bacteria receiving water limitations, contained within the Ocean Plan, outside of the initial dilution zone of the Oceanside OO. The time schedule shall include timelines for design, construction and implementation of any new or improved facilities needed for compliance.

VIII. PUBLIC PARTICIPATION

The San Diego Water Board is considering the issuance of WDRs that will serve as an NPDES permit for the Facility. As a step in the WDR adoption process, the San Diego Water Board has developed tentative WDRs. The San Diego Water Board encourages public participation in the WDR adoption process.

A. Notification of Interested Parties

The San Diego Water Board has notified FPUD and interested agencies and persons of its intent to prescribe WDRs for the discharge and has provided them with an opportunity

to submit their written comments and recommendations. Notification was published in the San Diego Union-Tribune and the North County Times on June 15, 2012 and posted on the San Diego Water Board web site on June 15, 2012.

B. Written Comments

Interested persons are invited to submit written comments concerning these tentative WDRs. Comments must be submitted either in person or by mail to the Executive Office at the San Diego Water Board at the address above on the cover page of this Order.

To be fully responded and considered by the San Diego Water Board, written comments must be received at the San Diego Water Board offices by 5:00 p.m. on July 16, 2012.

C. Public Hearing

The San Diego Water Board will hold a public hearing on the tentative WDRs during its regular board meeting on the following date and time and at the following location:

Date: August 8, 2012
Time: 9:00 AM
Location: Regional Water Quality Control Board
Regional Board Meeting Room
9174 Sky Park Court, Suite 100
San Diego, CA 92123

Interested persons are invited to attend. At the public hearing, the San Diego Water Board will hear testimony, if any, pertinent to the discharge, WDRs, and permit. Oral testimony will be heard; however, for accuracy of the record, important testimony should be in writing.

Please be aware that dates and venues may change. Our Web address is http://www.waterboards.ca.gov/sandiego/board_info/agendas/, where you can access the current agenda for changes in dates and locations.

D. Waste Discharge Requirements Petitions

Any aggrieved person may petition the State Water Resources Control Board to review the decision of the San Diego Water Board regarding the final WDRs. The petition must be submitted within 30 days of the San Diego Water Board's action to the following address:

State Water Resources Control Board
Office of Chief Counsel
P.O. Box 100, 1001 I Street
Sacramento, CA 95812-0100

E. Information and Copying

The Report of Waste Discharge (RWD), related documents, tentative effluent limitations and special provisions, comments received, and other information are on file and may be inspected at the address above at any time between 8:30 a.m. and 4:45 p.m., Monday

through Friday. Copying of documents may be arranged through the San Diego Water Board by calling (858) 467-2952.

F. Register of Interested Persons

Any person interested in being placed on the mailing list for information regarding the WDRs and NPDES permit should contact the San Diego Water Board, reference this facility, and provide a name, address, and phone number.

G. Additional Information

Requests for additional information or questions regarding this Order should be directed to Mr. Ben Neill at (858) 467-2983 or via email at bneill@waterboards.ca.gov.

ATTACHMENT G – DISCHARGE PROHIBITIONS CONTAINED IN THE 2005 CALIFORNIA OCEAN PLAN AND BASIN PLAN

I. Ocean Plan Discharge Prohibitions

1. The Discharge of any radiological chemical, or biological warfare agent or high-level radioactive waste into the ocean is prohibited.
2. Waste shall not be discharged to designated Areas of Special Biological Significance except as provided in Chapter III.E. of the Ocean Plan.
3. Pipeline discharge of sludge to the ocean is prohibited by federal law; the discharge of municipal and industrial waste sludge directly to the ocean, or into a waste stream that discharges to the ocean, is prohibited. The discharge of sludge digester supernatant directly to the ocean, or to a waste stream that discharges to the ocean without further treatment, is prohibited.
4. The by-passing of untreated wastes containing concentrations of pollutants in excess of those of Table A or Table B [of the Ocean Plan] is prohibited.

II. Basin Plan Discharge Prohibitions

1. The discharge of waste to waters of the State in a manner causing, or threatening to cause a condition of pollution, contamination or nuisance as defined in CWC section 13050, is prohibited.
2. The discharge of waste to land, except as authorized by WDRs of the terms described in CWC section 13264 is prohibited.
3. The discharge of pollutants or dredged or fill material to waters of the United States except as authorized by an NPDES permit or a dredged or fill material permit (subject to the exemption described in CWC section 13376) is prohibited.
4. Discharges of recycled water to lakes or reservoirs used for municipal water supply or to inland surface water tributaries thereto are prohibited, unless this San Diego Water Board issues an NPDES permit authorizing such a discharge; the proposed discharge has been approved by the State of California Department of Public Health and the operating agency of the impacted reservoir; and the discharger has an approved fail-safe long-term disposal alternative.
5. The discharge of waste to inland surface waters, except in cases where the quality of the discharge complies with applicable receiving water quality objectives, is prohibited. Allowances for dilution may be made at the discretion of the San Diego Water Board. Consideration would include streamflow data, the degree of treatment provided and safety measures to ensure reliability of facility performance. As an example, discharge of secondary effluent would probably be permitted if streamflow provided 100:1 dilution capability.
6. The discharge of waste in a manner causing flow, ponding, or surfacing on lands not owned or under the control of the discharger is prohibited, unless the discharge is authorized by the San Diego Water Board.

7. The dumping, deposition, or discharge of waste directly into waters of the State, or adjacent to such waters in any manner which may permit its being transported into the waters, is prohibited unless authorized by the San Diego Water Board.
8. Any discharge to a storm water conveyance system that is not composed entirely of storm water is prohibited unless authorized by the San Diego Water Board. [The federal regulations, 40 CFR 122.26(b)(13), define storm water as storm water runoff, snow melt runoff, and surface runoff and drainage. 40 CFR 122.26(b)(2) defines an illicit discharge as any discharge to a storm water conveyance system that is not composed entirely of storm water except discharges pursuant to an NPDES permit and discharges resulting from fire fighting activities.] [Section 122.26 amended at 56 FR 56553, November 5, 1991; 57 FR 11412, April 2, 1992].
9. The unauthorized discharge of treated or untreated sewage to waters of the State or to a storm water conveyance system is prohibited.
10. The discharge of industrial wastes to conventional septic tank/ subsurface disposal systems, except as authorized by the terms described in CWC section 13264, is prohibited.
11. The discharge of radioactive wastes amenable to alternative methods of disposal into the waters of the State is prohibited.
12. The discharge of any radiological, chemical, or biological warfare agent into waters of the State is prohibited.
13. The discharge of waste into a natural or excavated site below historic water levels is prohibited unless the discharge is authorized by the San Diego Water Board.
14. The discharge of sand, silt, clay, or other earthen materials from any activity, including land grading and construction, in quantities which cause deleterious bottom deposits, turbidity or discoloration in waters of the State or which unreasonably affect, or threaten to affect, beneficial uses of such waters is prohibited.
15. The discharge of treated or untreated sewage from vessels to Mission Bay, Oceanside Harbor, Dana Point Harbor, or other small boat harbors is prohibited.
16. The discharge of untreated sewage from vessels to San Diego Bay is prohibited.
17. The discharge of treated sewage from vessels to portions of San Diego Bay that are less than 30 feet deep at MLLW is prohibited.
18. The discharge of treated sewage from vessels, which do not have a properly functioning USCG certified Type 1 or Type II marine sanitation device, to portions of San Diego Bay that are greater than 30 feet deep at MLLW is prohibited.