

Exhibit No. 19

**CALIFORNIA REGIONAL WATER QUALITY CONTROL BOARD - SAN DIEGO REGION
WATERSHED PROTECTION PROGRAM**

FACILITY INSPECTION REPORT

FACILITY: Valencia
WDID/FILE NO.: 937C369143

INSPECTION DATE/TIME: 5/13/2015; 11:30 am

REPRESENTATIVE(S) PRESENT DURING INSPECTION:

NAME: Wayne Chiu

AFFILIATION: San Diego Water Board

NAME: Frank Melbourn

AFFILIATION: San Diego Water Board

NAME: _____

AFFILIATION: _____

San Altos Lemon Grove LLC
NAME OF OWNER, AGENCY OR PARTY RESPONSIBLE FOR DISCHARGE

BCA Development, Inc.
FACILITY OR DEVELOPER NAME (if different from owner)

5780 Fleet Avenue
Carlsbad, CA 92008
OWNER MAILING ADDRESS

1350 San Altos Place
Lemon Grove, CA 91945
FACILITY ADDRESS

Ben Anderson, 714-966-1544
OWNER CONTACT NAME AND PHONE #

Same
FACILITY OR DEVELOPER CONTACT NAME AND PHONE #

APPLICABLE WATER QUALITY LICENSING REQUIREMENTS:

- | | |
|---|---|
| <input type="checkbox"/> MS4 URBAN RUNOFF REQUIREMENTS | <input type="checkbox"/> GENERAL OR INDIVIDUAL WASTE DISCHARGE REQUIREMENTS OR NPDES |
| <input checked="" type="checkbox"/> CONSTRUCTION GENERAL PERMIT | <input type="checkbox"/> GENERAL OR INDIVIDUAL WAIVER OF WASTE DISCHARGE REQUIREMENTS |
| <input type="checkbox"/> CALTRANS GENERAL PERMIT | <input type="checkbox"/> SECTION 401 WATER QUALITY CERTIFICATION |
| <input type="checkbox"/> INDUSTRIAL GENERAL PERMIT | <input type="checkbox"/> CWC SECTION 13264 |

INSPECTION TYPE (Check One):

- "A" TYPE COMPLIANCE--COMPREHENSIVE INSPECTION IN WHICH SAMPLES ARE TAKEN. (EPA TYPE S)
- "B" TYPE COMPLIANCE--A ROUTINE NONSAMPLING INSPECTION. (EPA TYPE C)
- NONCOMPLIANCE FOLLOW-UP--INSPECTION MADE TO VERIFY CORRECTION OF A PREVIOUSLY IDENTIFIED VIOLATION.
- ENFORCEMENT FOLLOW-UP--INSPECTION MADE TO VERIFY THAT CONDITIONS OF AN ENFORCEMENT ACTION ARE BEING MET.
- COMPLAINT--INSPECTION MADE IN RESPONSE TO A COMPLAINT.
- PRE-REQUIREMENT--INSPECTION MADE TO GATHER INFO. RELATIVE TO PREPARING, MODIFYING, OR RESCINDING REQUIREMENTS.
- NO EXPOSURE CERTIFICATION (NEC) - VERIFICATION THAT THERE IS NO EXPOSURE OF INDUSTRIAL ACTIVITIES TO STORM WATER.
- NOTICE OF TERMINATION REQUEST FOR INDUSTRIAL FACILITIES OR CONSTRUCTION SITES - VERIFICATION THAT THE FACILITY OR CONSTRUCTION SITE IS NOT SUBJECT TO PERMIT REQUIREMENTS.
- COMPLIANCE ASSISTANCE INSPECTION - OUTREACH INSPECTION DUE TO DISCHARGER'S REQUEST FOR COMPLIANCE ASSISTANCE.

INSPECTION FINDINGS:

Y WERE VIOLATIONS NOTED DURING THIS INSPECTION? (YES/NO/PENDING SAMPLE RESULTS)

Facility: Valencia
Inspection Date: 5/13/2015

I. COMPLIANCE HISTORY / PURPOSE OF INSPECTION

On December 2, 2014, the City of Lemon Grove (City) issued a Stop Work/Notice of Violation to the Valencia construction site (WDID 9 37C369143) for failing to implement construction storm water best management practices (BMPs) required by local ordinances. The City's inspection report issued with the Stop Work/Notice of Violation noted inadequate implementation of erosion controls, entrance/exit stabilization, and stockpile management and warned the project manager that a "discharge is imminent" without adequate BMPs. The site was required to stop work and implement BMPs to be prepared for a storm event that occurred on December 3 and 4, 2014.

The site failed to implement BMPs before the storm, resulting in unauthorized discharges of sediment and sediment-laden storm water from the site to the City's municipal separate storm sewer system (MS4). The City issued a second Stop Work/Notice of Violation on December 4, 2014 for the illegal discharges to the City's MS4. The City conducted a follow up inspection on December 9, 2014 and noted the same BMP deficiencies identified before the December 3 and 4, 2014 storm event, as well as additional deficiencies in perimeter sediment controls. The inspection report provided recommendations for locations that needed to be addressed and types of BMPs. The site again failed to implement BMPs before a subsequent storm event that occurred on December 11, 2014, again resulting in unauthorized discharges of sediment and sediment-laden storm water from the site to the City's MS4. On December 11, 2014, the City issued an Administrative Citation to the site requiring BMPs to be implemented by December 15, 2014 before monetary penalties would begin. The Stop Work/Notice of Violation issued on December 2 and 4, 2014 and the Administrative Citation issued on December 11, 2014 by the City are attached to the end of this inspection report.

On December 15, 2014, Wayne Chiu of the San Diego Water Board inspected the site for compliance with the requirements of the Statewide Construction General Storm Water Permit, Order No. 2009-0009-DWQ (CGP). According to the Storm Water Multiple Application & Report Tracking System (SMARTS), the site is a Risk Level 2 construction site, disturbing over 18 acres, and owned by San Alto Lemon Grove LLC. The developer of the site is BCA Development, Inc. During the inspection, the San Diego Water Board observed evidence of inadequate implementation of stockpile management, vehicle storage and maintenance, erosion control, sediment control, run-on and runoff control, and inspection, maintenance, and repair requirements. In addition, there was evidence of inadequate implementation of additional erosion and sediment controls required for Risk Level 2 construction sites. On December 19, 2014, the San Diego Water Board issued Notice of Violation No. R9-2014-0153 to the Discharger and requested a written response demonstrating that the violations were corrected. The Discharger provided a written response, dated January 1, 2015. On January 26, 2015, the City provided written notification to the San Diego Water Board that the Stop Work had been removed for the site on January 22, 2015.

Facility: Valencia
Inspection Date: 5/13/2015

On March 27, 2015, the San Diego Water Board conducted a follow up inspection to determine if the site had adequately implemented BMPs that achieve BAT and BCT for a Risk Level 2 construction site. While standing at the intersection of Orlando Drive and Seville Way on the site, San Diego Water Board inspector, Frank Melbourn, warned Discharger representatives that the failure to have erosion and sediment control BMPs on Seville Way was a violation of the CGP, and would likely result in a sediment discharge from the site if there were to be a rain event. Discharger representatives claimed that if the site were to have another rain event, they would build a dirt berm at the top of Seville Way to prevent runoff from discharging down Seville Way. San Diego Water Board inspector, Wayne Chiu, found that the Discharger implemented corrective actions that largely addressed the violations identified in Notice of Violation No. R9-2015-0153.

On May 8, 2015, Frank Melbourn of the San Diego Water Board inspected the site following a rain event of approximately 0.5 inches. The inspector observed inadequate implementation of erosion controls in several inactive areas and active areas, perimeter sediment controls, linear sediment controls on several slopes, and run-on and runoff controls within and around the site. Evidence of sediment transport through the site observed on paved streets within the site, and an unauthorized discharge of sediment from the site to the Encanto Channel (a tributary to Chollas Creek) and Akins Road adjacent to the site.

On May 13, 2015, Wayne Chiu and Frank Melbourn of the San Diego Water Board conducted a subsequent inspection to determine if the site was implementing BMPs in preparation for a rain event forecasted for the following day.

II. FINDINGS

1. Several **stockpiles observed without adequate containment** (See Photos 1 and 2). All construction sites are required to contain and securely protect stockpiled waste material from wind and rain at all times unless actively being used.
2. Construction **equipment and vehicles observed without** appropriate BMPs (e.g. **drip pans**) to prevent oil, grease, or fuel to leak in to the ground, storm drains, or surface waters (See Photo 3). All construction sites are required to prevent oil, grease or fuel to leak in to the ground, storm drains, or surface waters, and to place all equipment and vehicles, which are to be fueled, maintained and stored in a designated area fitted with appropriate BMPs.
3. Several **areas were observed to be inactive**, or could be scheduled to be inactive, **without effective soil cover** to control potential erosion. Several completed building pads and several inactive slopes (See Photos 4 through 6) lacked any effective soil cover for erosion control. All construction sites are required to provide effective soil cover for inactive areas (i.e. areas that have been disturbed and not scheduled to be re-disturbed for at least 14 days) and all finished slopes, open space, utility backfill, and completed lots.

Facility: Valencia
Inspection Date: 5/13/2015

4. **Active areas** were observed to **lack appropriate erosion control BMPs** (runoff control and soil stabilization) to prevent erosion during storm events (See Photos 7 through 12). Risk Level 2 construction sites are required to implement appropriate erosion control BMPs (runoff control and soil stabilization) in conjunction with sediment control BMPs for areas under active construction.
5. Several slopes throughout the site were observed to **lack linear sediment controls** along the toe and grade breaks of exposed slopes (See Photos 1, 5, 6, 8, 9, 11, and 12). Risk Level 2 construction sites are required to apply linear sediment controls along the toe of the slope, face of the slopes, and at the grade breaks of exposed slopes to comply with sheet flow lengths given in Table 1 of Attachment D to the CGP.
6. Lack of effective perimeter sediment controls observed (See Photos 13 and 14). All construction sites are required to establish and maintain effective perimeter controls and stabilize all construction entrances and exits to sufficiently control erosion and sediment discharges from the site.
7. **Lack of effective run-on and runoff controls** observed within and around the site (See Photos 7 through 14). All construction sites are required to effectively manage run-on, all runoff within the site and all runoff that discharges off the site.
8. There were no personnel on site that appeared to be implementing BMPs to prepare for the forecasted rain event, such as erosion control measures or controls within the site to reduce sheet flow runoff lengths in active areas, or inspecting the perimeter controls for areas requiring additional attention, repairs, or maintenance.

III. COMMENTS AND RECOMMENDATIONS

Comments

1. There is evidence that good site management "housekeeping" BMPs were not being adequately implemented (See Findings 1 and 2).
2. There is evidence that erosion controls were not adequately implemented for several inactive areas contributing to discharges of sediment from the site (See Finding 3).
3. There is evidence that erosion controls were not adequately implemented for several active areas prior to storm events (See Finding 4).
4. There is evidence that linear sediment controls were not adequately implemented for several exposed slopes (See Finding 5).

Facility: Valencia
 Inspection Date: 5/13/2015

5. There is evidence that perimeter sediment controls, as well as run-on and runoff controls, were not adequately implemented (See Findings 6 and 7).
6. There is evidence that either the QSP was not adequately identifying and recommending implementation of good site management "housekeeping," erosion control, sediment control, and run-on/runoff control BMPs, or the owner/developer was not directing the implementation of the BMPs as recommended by the QSP (See Finding 8).
7. There was evidence observed during the inspection that the site has not implemented BMPs to meet BCT Technology Based Effluent Limitations (TBELs) under Section V.A.2 of the CGP, as required for all construction sites, which resulted in the unauthorized discharges of sediment and sediment-laden water from the site observed or documented on December 4, 11, and 15, 2014 (See Compliance History discussion and Findings 1 through 8).

Recommendations

The Discharger has failed to maintain compliance with the requirements of the CGP even after repeated enforcement actions by the City of Lemon Grove and the San Diego Water Board. A formal enforcement action should be issued to the Discharger for this continued and repeated noncompliance with the requirements of the CGP.

IV. SIGNATURE SECTION

Wayne Chiu
 STAFF INSPECTOR

 SIGNATURE

5/13/2015
 INSPECTION DATE

Eric Becker
 REVIEWED BY SUPERVISOR

 SIGNATURE

5/20/15
 DATE

SMARTS:

Tech Staff Info & Use	
WDID	937C369143
Place ID	SM-828060
Inspection ID	2025695
Violation ID	857243

Facility: Valencia
Inspection Date: 5/13/2015



Photo 1



Photo 2

Photos 1 and 2 shows soil **stockpiles** covered with black plastic **without adequate containment**. Slope in Photo 1 covered with white plastic lacks linear sediment controls at the based and at grade break along top of slope.



Photo 3

Photo 3 shows **construction vehicle without** appropriate BMPs (e.g. **drip pans**) to prevent oil, grease, or fuel to leak in to the ground, storm drains, or surface waters.

Facility: Valencia
Inspection Date: 5/13/2015



Photo 4



Photo 5



Photo 6

Photos 4 through 6 show several **inactive areas**, or areas that can be made to be inactive, **lacking any effective soil cover**. Photo 4 shows a completed lot that could have been stabilized with an effective soil cover and protected from activity. Photo 5 shows a slope that appeared to be inactive and potentially finished without effective soil cover. Photo 6 shows a slope in front of a building being constructed that could have been stabilized with an effective soil cover and made to be inactive.

Facility: Valencia
Inspection Date: 5/13/2015



Photo 7



Photo 8



Photo 9



Photo 10



Photo 11



Photo 12

Photos 9 through 12 showed several **active areas** of the site that **lacked** any evidence of **soil stabilization** measures ready to be implemented to reduce erosion potential or other measures to reduce sheet flow lengths. Photos 8, 9, 11, and 12 are slopes toward where runoff would flow toward a low point and perimeter of the site.

Facility: Valencia
Inspection Date: 5/13/2015



Photo 13



Photo 14

Photos 13 and 14 show areas of the perimeter where additional attention, repair, or maintenance is necessary to ensure the site has effective perimeter sediment controls to prevent erosion and sediment discharges from the site.

**CALIFORNIA REGIONAL WATER QUALITY CONTROL BOARD - SAN DIEGO REGION
WATERSHED PROTECTION PROGRAM**

FACILITY INSPECTION REPORT

FACILITY: Valencia Hills **INSPECTION DATE/TIME:** May 15, 2015; 13:30 **WDID/FILE NO.:** 93 7C369143

REPRESENTATIVE(S) PRESENT DURING INSPECTION:

NAME: <u>Frank Melbourn</u>	AFFILIATION: <u>San Diego Water Board</u>
NAME: <u>Tim Anderson, Site Superintendent</u>	AFFILIATION: <u>New Pointe Communities, Inc.</u>
NAME: <u>Tyler Sandstrom, Project Manager</u>	AFFILIATION: <u>New Pointe Communities, Inc.</u>

San Altos-Lemon Grove, LLC
NAME OF OWNER, AGENCY OR PARTY RESPONSIBLE FOR DISCHARGE

BCA Development, Inc.
FACILITY OR DEVELOPER NAME (if different from owner)

5780 Fleet Avenue
Carlsbad, CA 92008
OWNER MAILING ADDRESS

1350 San Altos Place
Lemon Grove, CA 91945
FACILITY ADDRESS

Ben Anderson, 714-966-1544
OWNER CONTACT NAME AND PHONE #

Same
FACILITY OR DEVELOPER CONTACT NAME AND PHONE #

APPLICABLE WATER QUALITY LICENSING REQUIREMENTS:

- | | |
|---|---|
| <input type="checkbox"/> MS4 URBAN RUNOFF REQUIREMENTS | <input type="checkbox"/> GENERAL OR INDIVIDUAL WASTE DISCHARGE REQUIREMENTS OR NPDES |
| <input checked="" type="checkbox"/> CONSTRUCTION GENERAL PERMIT | <input type="checkbox"/> GENERAL OR INDIVIDUAL WAIVER OF WASTE DISCHARGE REQUIREMENTS |
| <input type="checkbox"/> CALTRANS GENERAL PERMIT | <input type="checkbox"/> SECTION 401 WATER QUALITY CERTIFICATION |
| <input type="checkbox"/> INDUSTRIAL GENERAL PERMIT | <input type="checkbox"/> CWC SECTION 13264 |

INSPECTION TYPE (Check One):

- "A" TYPE COMPLIANCE--COMPREHENSIVE INSPECTION IN WHICH SAMPLES ARE TAKEN. (EPA TYPE S)
- "B" TYPE COMPLIANCE--A ROUTINE NONSAMPLING INSPECTION. (EPA TYPE C)
- NONCOMPLIANCE FOLLOW-UP--INSPECTION MADE TO VERIFY CORRECTION OF A PREVIOUSLY IDENTIFIED VIOLATION.
- ENFORCEMENT FOLLOW-UP--INSPECTION MADE TO VERIFY THAT CONDITIONS OF AN ENFORCEMENT ACTION ARE BEING MET.
- COMPLAINT--INSPECTION MADE IN RESPONSE TO A COMPLAINT.
- PRE-REQUIREMENT--INSPECTION MADE TO GATHER INFO. RELATIVE TO PREPARING, MODIFYING, OR RESCINDING REQUIREMENTS.
- NO EXPOSURE CERTIFICATION (NEC) - VERIFICATION THAT THERE IS NO EXPOSURE OF INDUSTRIAL ACTIVITIES TO STORM WATER.
- NOTICE OF TERMINATION REQUEST FOR INDUSTRIAL FACILITIES OR CONSTRUCTION SITES - VERIFICATION THAT THE FACILITY OR CONSTRUCTION SITE IS NOT SUBJECT TO PERMIT REQUIREMENTS.
- COMPLIANCE ASSISTANCE INSPECTION - OUTREACH INSPECTION DUE TO DISCHARGER'S REQUEST FOR COMPLIANCE ASSISTANCE.

INSPECTION FINDINGS:

Y WERE VIOLATIONS NOTED DURING THIS INSPECTION? (YES/NO/PENDING SAMPLE RESULTS)

Facility: Valencia Hills
Inspection Date: May 15, 2015

I. COMPLIANCE HISTORY / PURPOSE OF INSPECTION

Follow-up to May 13, 2015, San Diego Water Board inspection to determine if Best Management Practices (BMPs) were deployed, and if so were they effective and in compliance with the State Water Resources Control Board's General Construction Storm Water Permit, Order No. 2009-0009-DWQ, NPDES No. CAS000002, as amended by Order Nos. 2010-0014-DWQ and 2012-0006-DWQ (Permit), during the storm event of May 14-15, 2015.

II. FINDINGS

1. During the inspection, the sky was mostly cloudy with sporadic sprinkles. There were light winds; and the temperature was in the low 60's (Fahrenheit). The National Oceanic and Atmospheric Administration (NOAA) weather station for La Mesa reported receiving 0.74 inches of precipitation on May 15, 2015; and 0.11 inches on May 14, 2015. The NOAA Lemon Grove station did not collect weather information; therefore the closest NOAA station to Lemon Grove was cited.
2. I met Tim Anderson (949-275-6739), site superintendent for New Pointe Communities, Inc., at the site and I received permission from him to walk the site and to take photographs during the site inspection. Tim informed me that New Pointe Communities, Inc. had taken over for BCA Development, Inc., and that Bob Rowdine of Guardian Capital Realty will be submitting a Change of Information (COI) form. We walked the 19-acre site together and stopped at various points along the way to discuss the effectiveness of installed BMPs, identify areas that were out of compliance, and to discuss options for employing BMPs to come into compliance with the Permit. Tim stated that he had been on site since 6 a.m., and that he and his work crews had been adjusting BMPs throughout the day to improve their effectiveness during the storm event. Around 1:40 p.m., we were joined by Tyler Sandstrom.
3. Many flat graded areas have **no erosion or sediment control measures** in violation of the Permit (Attachment D §§ D.2 and E.3). Tim assured me during the walk through that next week he will spray the areas with a soil stabilizer. Tim also expressed confidence that the dirt berms on the north end of Tangelos Place and at the north end of Seville Way will hold back accumulated storm water runoff and eroded sediment. Tim additionally said that Tangelos Place will be paved next week.

Facility: Valencia Hills
Inspection Date: May 15, 2015

4. A few gravel bag chevrons were observed on Orlando Drive and Avalon Way. There was evidence of trapped sediment behind the chevrons. I recommended that Tim consider increasing the number of chevrons in order to slow down the runoff and trap more sediment. I also pointed out that sediment in the street indicates the need for erosion control measures on the graded areas of the site. At most there were three chevrons on the north side of Avalon Way. After the inspection, while I was in my office, I reviewed the site's Storm Water Pollution Prevention Plan (SWPPP) that was uploaded to the SMARTS database, and it indicated that there should be 14 chevrons.
5. Parkway planters and front yards along Avalon Way had **no erosion control** measures and many erosion rills were observed. Gravel bags were employed at the lowest ends of the parkway planters and front yards to contain sediment. I discussed the use of sprayed soil stabilization here with Tim. Tim stated that the parkway planters and front yards will be landscaped within the next few weeks. Again the BMPs noted in the SWPPP were not installed in the field at the site.
6. Additional gravel bags (to increase freeboard) were added at the creek crossing near the San Altos Place site entrance in an attempt to prevent sediment discharges into the creek. I advised Tim to consider spraying the graded areas with soil stabilization.
7. Gravel bags were placed in front of the storm drain inlet located at the east end of Akins Avenue. This was also done for the large storm drain inlet along the south end of Tangelos Place.
8. The ripped white plastic stockpile covers on the south side of Seville Way have been replaced with black plastic.

III. COMMENTS

Comments

1. There is evidence that either the QSP was not adequately identifying and recommending implementation of good site management "housekeeping," erosion control, sediment control, and run-on/runoff control BMPs, or the owner/developer was not directing the implementation of the BMPs as recommended by the QSP.
2. The majority of the BMPs specified in the SWPPP have not been installed in the field.

CALIFORNIA REGIONAL WATER QUALITY CONTROL BOARD-SAN DIEGO REGION

Facility: Valencia Hills
 Inspection Date: May 15, 2015

IV. SIGNATURE SECTION

Frank Melbourn	<i>Frank Melbourn</i>	May 22, 2015
STAFF INSPECTOR	SIGNATURE	INSPECTION DATE
Eric Becker	<i>Eric Becker</i>	5/24/15
REVIEWED BY SUPERVISOR	SIGNATURE	DATE

SMARTS:

Tech Staff Info & Use	
WDID	937C369143
Place ID	SM-828060
Inspection ID	2025772
Violation ID	857267



Photograph No. 1: IMG_0350.jpg, taken by Frank Melbourn, San Diego Water Board

Photograph No. 1 looks north from Tangelos Place onto Evelyn Street (behind green fence). The photograph displays an earthen berm holding back storm water runoff and eroded sediment. The soil on this side of the construction site is highly erodible. Sprayed erosion control can be seen on the slopes, as well as fiber rolls for sediment control. Large gravel and a rocker plate are installed at the site entrance as sediment controls. There was an **absence of erosion controls** on the graded street. There were **no sediment controls** but for the earthen berm.

Facility: Valencia Hills
Inspection Date: May 15, 2015



Photograph No. 2: IMG_0354.jpg, taken by Frank Melbourn, San Diego Water Board

Photograph No. 2 looks south down Tangelos Place. The photograph displays a muddy thoroughfare without erosion and sediment control measures. Some, but not all of the stockpiles are covered with black plastic.

Facility: Valencia Hills
Inspection Date: May 15, 2015



Photograph No. 3: IMG_0356.jpg, taken by Frank Melbourn, San Diego Water Board

Photograph No. 3 looks southeast down Avalon Way. The photograph displays sediment buildup behind a gravel back chevron or check dam in the gutter. Gravel bags were also used as sediment controls on this house lot to decrease the sediment discharge to the curb. The downhill storm drain inlet is connected to an on-site sediment basin. Spraying a soil stabilizer on the graded housing pads would reduce the erosive threat and sediment load to the street and basin.

Facility: Valencia Hills
Inspection Date: May 15, 2015



Photograph No. 4: IMG_0359.jpg, taken by Frank Melbourn, San Diego Water Board

Photograph No. 4 looks northeast and upstream of the creek from the creek crossing near the San Altos Place entrance. The photograph displays the addition of a row of gravel bags to reduce the likelihood of a sediment discharge to the creek. Spraying the area with a soil stabilizer would greatly reduce the threat of a sediment discharge to the creek.

Facility: Valencia Hills
Inspection Date: May 15, 2015



Photograph No. 5: IMG_0366.jpg, taken by Frank Melbourn, San Diego Water Board

Photograph No. 5 looks west from the south end of Tangelos Place at a storm drain inlet protected with gravel bags. There are no erosion or sediment control measures on Tangelos Place. Erosion rills and sediment buildup are displayed.



CITY OF LEMON GROVE ADMINISTRATIVE CITATION

A) TYPE OF VIOLATION

Circle One: Warning 1st Citation \$100 2nd Citation \$200 3rd Citation \$500 4th Citation \$1,000

Payment of \$ 1,000.00 is due no later than 10/22/2015 to the City of Lemon Grove.
The City accepts cash, check or credit card.

If the violation is not corrected by the date specified therein and/or payment is not received by the date above, the next level of citation may be issued, other enforcement actions may occur, and penalties may be assessed (25% and interest at the rate of 10% per month). Payment of fine does not excuse or discharge the failure to correct violation identified below.

B) RESPONSIBLE PARTY INFORMATION

Person Cited: Anderson (Last Name) Tim (First Name)

Circle One: Property Owner Tenant Business Owner Other Site Representative

Mailing Address: 3194-62 AIRPORT LOOP DRIVE, COSTA MESA, CA 92626

Business Name (if applicable): NEW POINT HOMES
CC: PHIL DOWLEY, CODE ENFORCEMENT FILE

C) VIOLATION(S) INFORMATION

Date (Violation Observed): 9/15/2015 Time (Violation Observed): 2pm

Location of Violation: 1350 SAN AITO'S PL/VALENCIA (Street Address) (APN)

Violation(s) Observed (Code Section and Description):
8.48.060 18.08.560 INADEQUATE BMP'S - SEE ATTACHED INSPECTION
18.08.170 EVIDENCE OF DISCHARGE REPORTS
18.08.190

D) CORRECTION(S) REQUIRED (with date to complete corrections)

INSTALL BMP'S PER RECOMMENDATIONS, ATTACHED REPORT

E) SERVICING CITATION INFORMATION

Enforcing Officer Name: Gary Harper Phone No.: 615 439-1272 Signature: [Signature] Date: 9/22/15
Person Cited - Signature Acknowledging Receipt: [Signature] Date: 9/22/15

Citation Served (circle one): In Person By Mail Posted on Property

This citation may be appealed within thirty (30) days from date of correction identified in Section D. To request an appeal, a Request an Appeal Hearing form (available at City Hall) should be completed and returned to City Hall. In the event a Hardship Waiver is requested, the Request for an Appeal Hearing and Hardship Waiver forms are required within fifteen (15) days from the correction date identified in Section D.



CITY OF LEMON GROVE
3232 Main Street, Lemon Grove, CA 91945

NPDES STORMWATER PROGRAM CONSTRUCTION STORMWATER COMPLIANCE INSPECTION FORM

Inspector Name /Signature/Date/Time: TAD NAKATANI [Signature] 9/15/15 2:00 PM

Inspection: Permit-Required Inspection Follow-up Inspection Other (Explain) _____

Construction Project Priority: High Medium Low

Approximate rainfall since last inspection: ~.8 inches

GENERAL INFORMATION

Grading or Building Permit #: GR-1692

Project Name & Type: Valencia Subdivision

Project Location & Address: San Altos Place

Contractor's Name & Telephone #: Anderson Development (949) 275-6739

Property Owner & Telephone #: San Altos LLC

Is this Project Greater than an Acre? Yes No N/A

If yes: Provide Record of Waste Discharge Identification Number (WDID#): 937C369143

Does this Project have an NOI/SWPPP Available? Yes No N/A

Is Weather Triggered Action Plan Completed? Yes No N/A

Is More than 17 Acres of Cleared or Graded Areas Left Exposed at Any Given Time? Yes No N/A

Sufficient Standby BMPs Onsite to Protect Site Within 48 Hours of Predicted Storm? Yes No N/A

Are Routine Self-Inspections Being Conducted by Developer/Owner? Yes No N/A

Project Site is in What Sub-Watershed: Chollas Creek 908.22 Sweetwater River 909.12

BMP	Yes	No	N/A	Description/Explanation	Effective Yes/No
Soil Stabilization and Erosion Prevention					
Preservation of existing vegetation?			<input checked="" type="checkbox"/>		
Physical Stabilization: Hydraulic Mulch, Hydroseeding, Soil Binders, Straw Mulch	<input checked="" type="checkbox"/>			Significant areas lack erosion control. Evidence of erosion throughout site	No
Geotextiles, Plastic Covers, Erosion Prevention Blankets, Wood Mulching	<input checked="" type="checkbox"/>			" "	No
Site Drainage: Outlet Protection/Slope Drain			<input checked="" type="checkbox"/>		
Inlet/Outlet Protection			<input checked="" type="checkbox"/>		
Sediment Control/Containment					
Perimeter Protection: Silt Fencing, Gravel Bags, Fiber Rolls	<input checked="" type="checkbox"/>			Some spots lack perimeter control (silt fence)	No
Storm Drain inlet protection: Sediment Trap, De-silting Basin, Gravel Bag Barrier	<input checked="" type="checkbox"/>			No inlet protection on drain near SE corner	No
Tracking Controls: Stabilized Entrance/Exit Road Stabilization, Tire Wash, Street Sweeping	<input checked="" type="checkbox"/>			Significant sediment on streets within project & in gutters on Akins. TCM needed on all driveways where vehicles will be driving	No

BMP	Yes	No	N/A	Description/Explanation	Effective Yes/No
Materials and Equipment Management					
Are materials and wastes stored in a manner that minimizes or eliminates the potential to discharge these materials to the storm drain system, is secondary containment used?	X				Yes
Are material stockpiles protected: covered, contained and located away from non-storm water discharges?	X			Some small sediment piles are not protected	No
Are heavy equipment and vehicles parked in designated areas with permeable surface?	X				Yes
Are appropriate spill response and containment measures kept on the site?	X				Yes
Are wastes managed and stored properly (Solid, liquid, sanitary, concrete, hazardous)		X		Some litter/waste throughout site	No
Are concrete washouts properly installed, maintained with no evidence of discharges.	X				Yes
Is timely service and removal provided to prevent waste containers and sanitary facilities from overflowing?	X				Yes
Non-Storm Water Management					
Is the site free of evidence of illegal connections and/or illicit discharges?	X				Yes
Discharge Locations					
Are the discharge locations free of significant erosion or sediment transport?		X		Some sediment in road and gutter near SE corner	No
Other					
Are there any other potential storm water pollution issues/concerns?	X			Sediment will need to be cleaned out of basins & erosion control inlets needs repair	No
Was there any employee or subcontractor training on stormwater BMPs?				Not discussed	

RECOMMENDED CORRECTIVE ACTION

SEE NEXT PAGE

Have any corrective actions from the previous inspection NOT been implemented? Yes No NA
 If NO, and if it has been more than 30 days since the corrective action was originally required, explain why more than 30 days was necessary to resolve the deficiency: less than 30 days since previous insp.

VIOLATIONS

- No violations noted at time of inspection/investigation.
- No violations; however, recommended corrective actions required
 - Inspection Form as Correct Work Notice Correct Work Notice Issued on: _____
- Violation: Illegal Discharge/Illegal Connection/Improper BMPs Implementation
 - Stop Work Notice Issued on: _____
- Violation

Construction BMP Recommendations

Site: VALENCIA

Date: 9/15/15

Recommendations:

- ① UTILIZE EROSION CONTROLS ON ALL DISTURBED AREAS PRIOR TO RAIN EVENTS, OR WHEN THEY ARE INACTIVE, WHICHEVER COMES FIRST
- ② PROTECT EXPOSED AREA FROM RUN-ON AND MAKE SURE AREA IS FULLY COVERED
- ③ ADD/IMPROVE PERIMETER CONTROLS
- ④ ADD TC-1 IF VEHICLES WILL BE DRIVING ACROSS DRIVEWAY
- ⑤ CLEAN SEDIMENT OUT OF ROADWAYS & GUTTER
- ⑥ ADD INLET PROTECTION
- ⑦ CLEAN SEDIMENT OUT OF BIORETENTION BASINS, SIGNIFICANT ACCUMULATION, ESPECIALLY BY INLETS
- ⑧ REPAIR EROSION BY BASIN INLETS. ALSO RECOMMEND CLEARING OBSTRUCTIONS IN OUTLET RISER STRUCTURE
- ⑨ PICK UP TRASH

Exhibit No. 23



D-MAX Engineering, Inc.

Consultants in Water & Environmental Sciences

Memo

Date: January 16, 2015

To: Leon Firsht, Malik Tamimi

Cc: John Quenzer

From: Tad Nakatani

Subject: Summary of Inspections and Sampling at Valencia Construction Site between December 9, 2014 and January 14, 2015

Per the City's request, D-MAX conducted multiple visits to the Valencia construction site to perform inspections and to collect storm water runoff samples. Table 1 summarizes the dates of all inspection and sampling visits.

Table 1. Inspection and Sampling Attempt Dates

Date	Activity
12/9/2014	Inspection
12/11/2014	Inspection
12/12/2014	Sampling
12/16/2014	Inspection
12/17/2014	Sampling
12/31/2014	Sampling
1/6/2015	Inspection
1/14/2015	Inspection

Summary of Inspections

Several significant BMP deficiencies were observed during the initial inspection on December 9, when the site was already under a Stop Work Notice from the City. Most significantly, there were several areas that lacked adequate erosion control BMPs, and there was also evidence of concentrated flows being directed to unstabilized areas, causing significant erosion. D-MAX documented these deficiencies and provided BMP recommendations as requested by the City. D-MAX re-inspected the site two days later on December 11 and observed that the majority of the deficiencies had not been corrected. On December 12, D-MAX visited the site during a rain event and collected samples of runoff from the site. Turbidity measurements were above 500 NTU for two samples taken near the southeast corner of the site and were above 400 NTU for a sample taken near the northeast corner of the site.

During the next inspection on December 16, some additional BMP deficiencies had been addressed, but the progress was still not sufficient. D-MAX returned to the site the following day to attempt to collect a sample, but the rain had already stopped, and no runoff sample was collected. D-MAX did observe sediment on the roadway outside of the southeast corner of the



site. A power-washing contractor was in the process of cleaning the road when D-MAX visited the site. D-MAX returned to the site on the morning of December 31 to attempt to collect another runoff sample, but once again the rain had stopped several hours before the site visit. D-MAX observed some sediment in the roadway again, but it appeared to be less than during the previous visit. D-MAX sampled water ponded at two locations just outside the southeast corner of the site. Turbidity was measured at 250 NTU and 235 NTU at these locations, but these measurements likely do not accurately reflect the turbidity of runoff since there had been time for sediment to settle out.

During the inspection on January 6, D-MAX observed that most of the major BMP deficiencies had been addressed, but a few still remained unresolved.

D-MAX performed its most recent inspection on January 14. D-MAX's assessment from this inspection is that the developer has made sufficient improvements to the site, and it is appropriate to lift the Stop Work Notice. There were some minor BMP deficiencies during the January 14 inspection, and the developer will still be required to address these promptly. However, the major deficiencies that led to the Stop Work Notice have been addressed, and the overall state of the site has been improved to the point where it no longer poses the severe risk of sediment discharges that it did in December.

Table 2 provides a summary of the different BMP deficiencies observed during inspections as well as the corrective actions that had been implemented as of January 14, 2015.

**Table 2. Summary of BMP Deficiencies Observed and Corrective Actions Taken**

BMP Deficiency	Corrective Action(s) Taken
Several lots lacked adequate erosion control BMPs.	Additional lots were hydroseeded. Some smaller areas were protected with plastic sheeting
Numerous slopes on the edges of lots were not sufficiently stabilized and protected from concentrated flows, and rills/gullies had formed.	Slopes were repaired where possible. BMPs were added upstream of slopes to prevent concentrated flows. Plastic sheeting was used in select areas to create protected spillways where concentrated flows could not be eliminated. Improved growth of hydroseed on slopes was also observed. All of the larger rills were addressed, but a few small rills still remained on January 14. The developer is required to address these areas still.
Sidewalls at the edges of lots also lacked erosion controls and several showed signs of erosion.	Sidewalls were protected with plastic sheeting.
Portions of the slope on the western edge of the site lacked full stabilization.	Additional fiber rolls were installed. Plastic sheeting was used to create protected spillways in areas where upstream contours were causing flows to concentrate.
Dirt roadways lacked sufficient stabilization and sediment controls.	Roads were compacted and large berms were built on them. A portion of the road that is inactive was hydroseeded.
Runoff from a significant portion of the site was being directed as concentrated flow to an unstabilized area in the site's southeast corner.	The developer built up an embankment to redirect flows away from this area and toward a settling area.
Some stockpiles lacked adequate cover	Covers were put on stockpiles.
The developer did not have sufficient quantities of BMP materials on site.	Additional gravel bags, fiber rolls, and silt fences were delivered to the site.
A significant amount of sediment was observed along the roadway at the southeast corner of the site.	Sweeping did not effectively remove all sediment, so a power-washing contractor was hired and removed the sediment from the road.
Gravel bag inlet protection BMPs were not always in place	Gravel bags were put in place to protect on-site and downstream off-site inlets.
Filter fabric used as part of inlet protection became potentially clogged by hydroseeding materials	Filter fabric was replaced.
Stockpiles were placed close to a drain inlet. The inlet is elevated above the ground height in that area, decreasing the risk of discharge, but stockpiles still need to be relocated away from the drain.	This deficiency was first observed on January 6. On January 14, the stockpiles had been covered, but they had not been moved sufficiently far enough away from the drain inlet. The developer is still required to address this item.
Sediment control BMPs were lacking or damaged in places.	A significant amount of additional silt fences and gravel bags were added to the site perimeter and the perimeters of lots.



Summary of Inspections and Sampling at Valencia Construction Site
January 16, 2015
Page 4 of 6



Photo 1. Lot lacking erosion control BMPs



Photo 2. Hydroseed added to a lot



Photo 3. Evidence of erosion at edge of a lot



Photo 4. Rills filled in, area re-hydroseeded, silt fence added to perimeter of lot.



Summary of Inspections and Sampling at Valencia Construction Site

January 16, 2015

Page 6 of 6



Photo 5. Sidewall without adequate erosion control



Photo 6 Sidewall protected with plastic sheeting.



CITY OF LEMON GROVE
3232 Main Street, Lemon Grove, CA 91945

NPDES STORMWATER PROGRAM CONSTRUCTION STORMWATER COMPLIANCE INSPECTION FORM

Inspector Name /Signature/Date/Time: TAD NAKATANI [Signature] 1/6/15 10:30AM

Inspection: Permit-Required Inspection Follow-up Inspection Other (Explain) _____

Construction Project Priority: High Medium Low

GENERAL INFORMATION

Grading or Building Permit #: GR-1692

Project Name & Type: VALENCIA SUBDIVISION

Project Location & Address: SAN ALTOS PLACE

Contractor's Name & Telephone #: ANDERSON DEVELOPMENT (949) 275-6739

Property Owner & Telephone #: SAN ALTOS LLC

Is this Project Greater than an Acre? Yes No N/A

If yes: Provide Record of Waste Discharge Identification Number (WDID#): 937C369143

Does this Project have an NOI/SWPPP Available? Yes No N/A

Is Weather Triggered Action Plan Completed? Yes No N/A

Is Advanced Treatment Implemented Appropriately? Yes No N/A

Is More than 17 Acres of Cleared or Graded Areas Left Exposed at Any Given Time? Yes No N/A

Is 125% of Materials to Install Standby BMPs Available? Yes No N/A

Are Routine Self-Inspections Being Conducted by Developer/Owner? Yes No N/A
Unclear: Have additional silt fences but may need more after installing on more lots

Project Site is in What Sub-Watershed: Chollas Creek 908.22 Sweetwater River 909.12

Nearest Conveyances or Water Bodies: ENCANTO CHANNEL TO CHOLLAS CREEK

BMP	Yes	No	N/A	Description/Explanation	Effective Yes/No
Soil Stabilization and Erosion Prevention					
Preservation of existing vegetation?			X		
Physical Stabilization: Hydraulic Mulch, Hydroseeding, Soil Binders, Straw Mulch	X			Area near Akins entrance not fully stabilized. Several gullies unprote ctcd	No
Geotextiles, Plastic Covers, Erosion Prevention Blankets, Wood Mulching	X			Additional gravel bags needed at base of plastic spillway on south side. Sidewalls lack plastic covering	No
Site Drainage: Outlet Protection/Slope Drain		X			
Inlet/Outlet Protection		X			
Sediment Control/Containment					
Perimeter Protection: Silt Fencing, Gravel Bags, Fiber Rolls	X			Additional fiber rolls needed on slope on west side	No
Storm Drain inlet protection: Sediment Trap, De-silting Basin, Gravel Bag Barrier	X			Fabric on drain in basin clogged with hydroseed. Bags along Akins have been removed & not replaced yet	No

BMP	Yes	No	N/A	Description/Explanation	Effective Yes/No
Tracking Controls: Stabilized Entrance/Exit Road Stabilization, Tire Wash, Street Sweeping	X				Yes
Materials and Equipment Management					
Are materials and wastes stored in a manner that minimizes or eliminates the potential to discharge these materials to the storm drain system, is secondary containment used?	X				Yes
Are material stockpiles protected: covered, contained and located away from non-storm water discharges?	X			Uncovered stockpiles reported as active	Yes
Are heavy equipment and vehicles parked in designated areas with permeable surface?	X				Yes
Are appropriate spill response and containment measures kept on the site?	X				Yes
Are wastes managed and stored properly (Solid, liquid, sanitary, concrete, hazardous)	X				Yes
Are concrete washouts properly installed, maintained with no evidence of discharges.	X				Yes
Is timely service and removal provided to prevent waste containers and sanitary facilities from overflowing?	X				Yes
Non-Storm Water Management					
Is the site free of evidence of illegal connections and/or illicit discharges?	X				Yes
Discharge Locations					
Are the discharge locations free of significant erosion or sediment transport?	X				Yes
Other					
Are there any other potential storm water pollution issues/concerns?	X			Stockpiles are too close to drain in NE Basin. Need to be moved or removed	No
Was there any employee or subcontractor training on stormwater BMPs?			X	Not Discussed	

VIOLATIONS

- No violations noted at time of inspection/investigation
- No violations; however, recommended corrective actions required
 - Inspection Form as Correct Work Notice Correct Work Notice Issued on: _____
- Violation: Illegal Discharge/Illegal Connection/Improper BMPs Implementation
 - Stop Work Notice Issued on: Ongoing stop work Admin. citation

RECOMMENDED CORRECTIVE ACTION

See next page for recommendations

Construction BMP Recommendations

Site: VALENCIA SUBDIVISION

Date: 1/6/15

Recommendations: (SEE MAP ON NEXT PAGE FOR LOCATIONS)

- ① FULLY STABILIZE AREA. UTILIZE OTHER EROSION CONTROL BMPs (E.G. VISQUEPE OR EROSION CONTROL BLANKETS) IF HYDROSEED GROWTH IS NOT SUFFICIENT
- ② CLEAN OR REPLACE FILTER FABRIC
- ③ MOVE OR REMOVE STOCKPILES THAT ARE ADJACENT TO DRAIN
- ④ REPAIR GULLIES AND PREVENT CONCENTRATED FLOW TO AREA
- ⑤ REPAIR & STABILIZE SLOPE
- ⑥ USE EROSION CONTROLS TO STABILIZE EXPOSED SIDEWALLS. CONSIDER METHODS OTHER THAN HYDROSEED SINCE THERE IS EVIDENCE OF FAILURE
- ⑦ STABILIZE AREA IF INACTIVE OR RAIN IN FORECAST
- ⑧ ADD GRAVEL BAGS AT BOTTOM OF SPILLWAY
- ⑨ REPLACE GRAVEL BAGS ALONG AKINS





CITY OF LEMON GROVE
3232 Main Street, Lemon Grove, CA 91945

NPDES STORMWATER PROGRAM CONSTRUCTION STORMWATER COMPLIANCE INSPECTION FORM

Inspector Name /Signature/Date/Time: TAD NAKATANI [Signature] 1/14/15 7:15AM

Inspection: Permit-Required Inspection Follow-up Inspection Other (Explain) _____

Construction Project Priority: High Medium Low

GENERAL INFORMATION

Grading or Building Permit #: GR-1692

Project Name & Type: VALENCIA SUBDIVISION

Project Location & Address: SAN ALTOS PLACE

Contractor's Name & Telephone #: ANDERSON DEVELOPMENT (949) 275-6739

Property Owner & Telephone #: SAN ALTOS LLC

Is this Project Greater than an Acre? Yes No N/A

If yes: Provide Record of Waste Discharge Identification Number (WDID#): 937C369143

Does this Project have an NOI/SWPPP Available? Yes No N/A

Is Weather Triggered Action Plan Completed? Yes No N/A

Is Advanced Treatment Implemented Appropriately? Yes No N/A

Is More than 17 Acres of Cleared or Graded Areas Left Exposed at Any Given Time? Yes No N/A

Is 125% of Materials to Install Standby BMPs Available? Yes No N/A

Are Routine Self-Inspections Being Conducted by Developer/Owner? Yes No N/A

Project Site is in What Sub-Watershed: Chollas Creek 908.22 Sweetwater River 909.12

Nearest Conveyances or Water Bodies: ENCANTO CHANNEL TO CHOLLAS CREEK

BMP	Yes	No	N/A	Description/Explanation	Effective Yes/No
Soil Stabilization and Erosion Prevention					
Preservation of existing vegetation?			X		
Physical Stabilization: Hydraulic Mulch, Hydroseeding, Soil Binders, Straw Mulch	X			Some areas near Alkins where hydro-seeding has not grown. Some remaining gullies on edges of lots.	No
Geotextiles, Plastic Covers, Erosion Prevention Blankets, Wood Mulching	X			Most sidewalks have been covered but a couple in the northern part of site lack protection	No
Site Drainage: Outlet Protection/Slope Drain		X			
Inlet/Outlet Protection		X			
Sediment Control/Containment					
Perimeter Protection: Silt Fencing, Gravel Bags, Fiber Rolls	X			Broken silt fence near San Altos	No
Storm Drain inlet protection: Sediment Trap, De-silting Basin, Gravel Bag Barrier					

BMP	Yes	No	N/A	Description/Explanation	Effective Yes/No
Tracking Controls: Stabilized Entrance/Exit Road Stabilization, Tire Wash, Street Sweeping	X				Yes
Materials and Equipment Management					
Are materials and wastes stored in a manner that minimizes or eliminates the potential to discharge these materials to the storm drain system, is secondary containment used?	X				Yes
Are material stockpiles protected: covered, contained and located away from non-storm water discharges?		X		Wood/scrub pile should be removed or protected	No
Are heavy equipment and vehicles parked in designated areas with permeable surface?	X				Yes
Are appropriate spill response and containment measures kept on the site?	X				Yes
Are wastes managed and stored properly (Solid, liquid, sanitary, concrete, hazardous)	X				Yes
Are concrete washouts properly installed, maintained with no evidence of discharges.	X				Yes
Is timely service and removal provided to prevent waste containers and sanitary facilities from overflowing?	X				Yes
Non-Storm Water Management					
Is the site free of evidence of illegal connections and/or illicit discharges?	X				Yes
Discharge Locations					
Are the discharge locations free of significant erosion or sediment transport?	X				Yes
Other					
Are there any other potential storm water pollution issues/concerns?	X			stockpiles are located too close to drain in NE Basin. Remove or relocate them outside of basin per discussion	No
Was there any employee or subcontractor training on stormwater BMPs?			X		

VIOLATIONS

- No violations noted at time of inspection/investigation
- No violations; however, recommended corrective actions required
 - Inspection Form as Correct Work Notice Correct Work Notice Issued on: _____
- Violation: Illegal Discharge/Illegal Connection/Improper BMPs Implementation
 - Stop Work Notice Issued on: ongoing stop work/Admin. citation

RECOMMENDED CORRECTIVE ACTION

see next page for recommendations

Construction BMP Recommendations

Site: VALENCIA SUBDIVISION

Date: 1/14/15

Recommendations:

- ① STABILIZE REMAINING SMALL AREAS THAT LACK FULL HYDROSEED OR VISQUENE COVER
- ② INSTALL EROSION CONTROLS ON REMAINING SIDEWALLS
- ③ REMOVE THE STOCKPILES THAT ARE NEAR THE DRAIN OR RELOCATE THEM OUTSIDE OF THE BASIN
- ④ REPAIR BROKEN SILT FENCE
- ⑤ STABILIZE AREA IF INACTIVE OR RAIN IN FORECAST
- ⑥ REMOVE OR PROTECT WOOD/SCRAP PILE
- ⑦ REPAIR MINOR RILLS AND PROTECT AGAINST CONCENTRATED FLOWS IN THE AREA

1/14/15





CITY OF LEMON GROVE ADMINISTRATIVE CITATION

A) TYPE OF VIOLATION

Circle One: Warning 1st Citation \$100 2nd Citation \$200 3rd Citation \$500 **6th Citation \$1,000**

Payment of \$ 1,000 is due no later than NOV 6, 2015 to the City of Lemon Grove.
The City accepts cash, check or credit card.

If the violation is not corrected by the date specified therein and/or payment is not received by the date above, the next level of citation may be issued, other enforcement actions may occur, and penalties may be assessed (25% and interest at the rate of 10% per month). Payment of fine does not excuse or discharge the failure to correct violation identified below.

B) RESPONSIBLE PARTY INFORMATION

Person Cited: Anderson (Last Name) Tim (First Name)

Circle One: Property Owner Tenant Business Owner Other Developer

Mailing Address: 3194-62 Airport Loop Dr. Costa Mesa, CA 92626

Business Name (if applicable): New Point Homes

C) VIOLATION(S) INFORMATION

Date (Violation Observed): OCT 5, 2015 Time (Violation Observed): 2:30pm

Location of Violation: SAN ANGE (VALENCIA) (Street Address) (APN)

Violation(s) Observed (Code Section and Description):
PER GRADING PLANS, # ~~2671~~ 2671, GRADING PERMIT #2014-01, SITE IS NOT IN COMPLIANCE WITH SHEET 11A, "EROSION CONTROL NOTES." SEE PHOTOS

D) CORRECTION(S) REQUIRED (with date to complete corrections)

17 DAYS OR BEFORE RAIN EVENT, SITE TO BE IN SUBSTANTIAL COMPLIANCE WITH GRADING PLANS

E) SERVICING CITATION INFORMATION

Enforcing Officer Name: GARY HARPER Phone No. 619 454-1272 Signature [Signature] Date OCT 5, 2015

Person Cited – Signature Acknowledging Receipt _____ (Date)

Citation Served (circle one): In Person **By Mail** Posted on Property
EMAIL

This citation may be appealed within thirty (30) days from date of correction identified in Section D. To request an appeal, a Request an Appeal Hearing form (available at City Hall) should be completed and returned to City Hall. In the event a Hardship Waiver is requested, the Request for an Appeal Hearing and Hardship Waiver forms are required within fifteen (15) days from the correction date identified in Section D.

Erosional SEDIMENT CONTROL VALENCIA OCT 5, 2015



Erosion/Sediment Control Valencia Oct 5, 2015



Erosion Control / Stockpile VALNCIA OCT 5, 2015



VALENCIA OCT 5, 2015 FAILURE TO MAINTAIN BARRIERS, EROSION CONTROL



Bmp Failure Valencia Oct 5, 2015



Erosion Control VALENCIA OCT 5, 2015



Exhibit No. 27
Site: Valencia Hills

Penalty Methodology Decisions
R9-2015-0110

Discharge Violation: Potential for Harm

Violations	Harm/Potential Harm to Beneficial Uses [0 -5]	Physical, Chemical, Biological or Thermal Characteristics [0 -4]	Susceptibility to Cleanup or Abatement [0 or 1]	Total Potential for Harm [0 - 10]
Violation 1	3	2	1	6

Discharge Violation

Violations	Total Potential for Harm [0 - 10]	Deviation from Requirement [minor, moderate, major]	Total per Day	Days of Violation	Statutory Max per [WC § 13385]	Culpability [0.5 - 1.5]	Cleanup and Cooperation [0.75 - 1.5]	History of Violations	Liability Amount	Economic Benefit	Liability	
											Minimum	Maximum
Violation 1	6	major	0.22	6	\$10,000	1.3	1.1	1.0	\$18,876	\$9,476	\$10,424	\$60,000

Non-Discharge Violations

Violations	Potential for Harm minor, moderate, major	Deviation from Requirement [minor, moderate, major]	Total per Day	Days of Violation	Statutory Max per [WC § 13385]	Culpability [0.5 - 1.5]	Cleanup and Cooperation [0.75 - 1.5]	History of Violations	Liability Amount	Economic Benefit	Liability	
											Minimum	Maximum
Violation 2	moderate	moderate	0.35	10	\$10,000	1.3	1.1	1.0	\$50,050	\$1,088	\$1,197	\$100,000
Violation 3	moderate	major	0.55	2	\$10,000	1.3	1.1	1.0	\$15,730	\$823	\$905	\$20,000
Violation 4	moderate	major	0.55	22	\$10,000	1.3	1.1	1.0	\$173,030	\$5,966	\$6,563	\$220,000
Violation 5	moderate	moderate	0.35	14	\$10,000	1.3	1.1	1.0	\$70,070	\$2,175	\$2,393	\$140,000
Violation 6	moderate	major	0.55	22	\$10,000	1.3	1.1	1.0	\$173,030	\$5,966	\$6,563	\$220,000
Violation 7	moderate	major	0.55	9	\$10,000	1.3	1.1	1.0	\$70,785	\$700	\$770	\$90,000
Violation 8	moderate	moderate	0.35	7	\$10,000	1.3	1.1	1.0	\$35,035	\$420	\$462	\$70,000
Violation 9	moderate	moderate	0.35	10	\$10,000	1.3	1.1	1.0	\$50,050	\$211	\$232	\$100,000
Violation 10	moderate	moderate	0.35	3	\$10,000	1.3	1.0	1.0	\$13,650	\$420	\$462	\$30,000
Violation 11	minor	moderate	0.25	9	\$10,000	1.3	1.1	1.0	\$32,175	\$315	\$347	\$90,000
Violation 12	major	moderate	0.55	7	\$10,000	1.3	1.1	1.0	\$55,055	\$1,985	\$2,184	\$70,000
Violation 13	minor	major	0.35	15	\$10,000	1.3	1.1	1.0	\$75,075	\$378	\$416	\$150,000

\$1,360,000

Ability to Pay & Continue in Business [Yes, No, Partly, Unknown]		Other
Yes		N/A

Other Factors as Justice May Require Costs of Investigation & Enforcement		Other
\$15,763		N/A

Total Liabilities
\$832,611

Total Liability (All liabilities plus staff costs)
\$848,374

Exhibit No. 28

Economic Benefit Calculation and Supporting Documentation

San Altos Lemon Grove, LLC - Valencia Hills (Region 9 - San Diego)

Caution: Use this spreadsheet as an "information only tool". It is not linked to BEN and will do no calculations. Please check with the ORPP economist Madalene Ransom (916 322-8417) before using this information to run BEN. And, contact your OE attorney before using the BEN results in preparing an ACLC or other actions that may in any way be controversial.

Compliance Action (List the actions which would have prevented the violation)	One-Time Nondepreciable Expenditure			Annual Cost		Non-Compliance Date	Compliance Date	Penalty Payment Date	Benefit of Noncompliance
	Amount	Date ¹	Delayed? ²	Amount	Date ¹				
1. Discharges: Spray three acres of bonded fiber matrix (\$4,000/acre), install 500 gravel bags (\$1/ea.) and install 1,000 feet of Fiber Rolls (\$1/ft.).	\$13,500	11/1/2009	N	\$0		12/1/2014	12/16/2015	12/16/2015	\$9,476
2. Stockpiles: Install 500 feet of fiber rolls (\$1/ft.) and 15,000 square feet (5x3,000) of plastic (\$0.07/square feet).	\$1,550	11/1/2009	N	\$0		12/2/2014	12/16/2015	12/16/2015	\$1,088
3. Vehicles: Install 5 drip pads (\$257.14 ea.).	\$1,286	1/21/2015	N	\$0		12/15/2014	12/16/2015	12/16/2015	\$823
4. Erosion Inactive: Spray two acres of bonded fiber matrix (\$4,000/acre), and install 500 gravel bags (\$1/ea.).	\$8,500	11/1/2009	N	\$0		12/1/2014	12/16/2015	12/16/2015	\$5,966
5. Perimeter Sediment BMPs: Install 500 feet of fiber rolls (\$1/ft.), 200 gravel bags (\$1/ea.), and a stabilized entrance (\$2,400 ea.).	\$3,100	11/1/2009	N	\$0		12/4/2014	5/15/2015	12/16/2015	\$2,175
6. Erosion Active: Spray two acres of bonded fiber matrix (\$4,000/acre) and install 500 feet of fiber rolls (\$1/ft.).	\$8,500	11/1/2009	N	\$0		12/1/2014	12/16/2015	12/16/2015	\$5,966
7. Linear Sediment: Install 1,000 feet of fiber rolls (\$1/ft.).	\$1,000	11/1/2009	N	\$0		12/15/2014	12/16/2015	12/16/2015	\$700
8. Run-On/Runoff: Install 500 feet of fiber rolls (\$1/ft.) and 100 gravel bags (\$1/bag).	\$600	11/1/2009	N	\$0		12/15/2014	12/16/2015	12/16/2015	\$420
9. Remove Sed Roads: Four hours of street sweeping (\$75/hr.).	\$300	11/1/2009	N	\$0		12/2/2014	12/8/2014	12/16/2015	\$211
10. Storm Drain Inlet Protection: Install and maintain inlet protection (\$200/ea.).	\$600	11/1/2009	N	\$0		12/8/2014	12/9/2014	12/16/2015	\$420
11. Waste Stockpiles: Install 175 feet fiber rolls (\$1/ft.) and 4,000 sq. ft. of plastic (\$0.07/square feet).	\$455	11/1/2009	N	\$0		1/6/2015	1/15/2015	12/16/2015	\$315
12. Chemical Storage:	\$3,213	9/2/2015	N	\$0		3/18/2015	3/25/2015	12/16/2015	\$1,985
13. Concrete Waste: Rent one concrete washout bin (delivery \$475 plus 8% fuel surcharge, and \$7/day).	\$618	9/15/2014	N	\$0		3/18/2015	3/25/2015	12/16/2015	\$378
Totals	calculated by BEN								\$29,923

Cost Index for Inflation:	PCI		PCI	See Table 1 below for Index choices.	Date/Time of Information:
---------------------------	-----	--	-----	--------------------------------------	---------------------------

Income Tax Schedule: **C** See Table 2 below for choices.

Discount/Compound Rate: **7.5%** This percentage provided by BEN

Source: USEPA BEN Model: **Version 5.5.0**

Person gathering information: **Frank Melbourn**

¹ Date cost estimate was made.

² Enter "y" if delayed, and "n" if avoided.

Violation No. 1

Unauthorized Discharge of Sediment
(6 days)

Fiber Rolls

SE-5

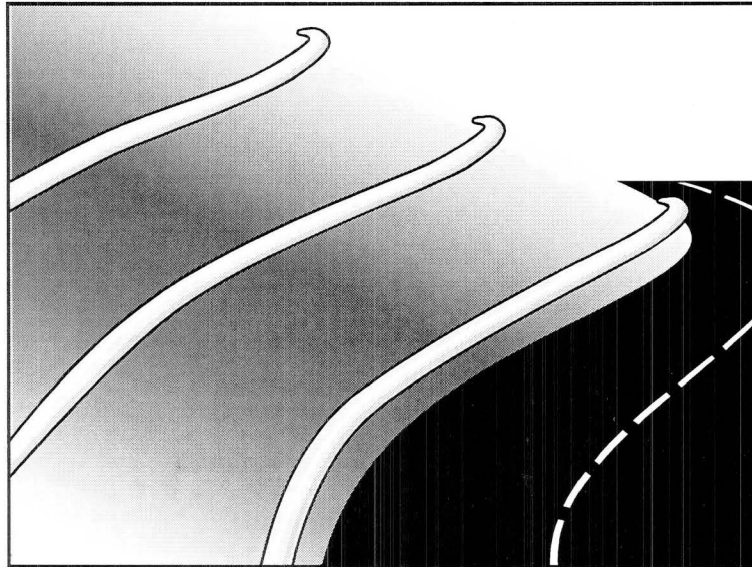

Description and Purpose

A fiber roll consists of straw, coir, or other biodegradable materials bound into a tight tubular roll wrapped by netting, which can be photodegradable or natural. Additionally, gravel core fiber rolls are available, which contain an imbedded ballast material such as gravel or sand for additional weight when staking the rolls are not feasible (such as use as inlet protection). When fiber rolls are placed at the toe and on the face of slopes along the contours, they intercept runoff, reduce its flow velocity, release the runoff as sheet flow, and provide removal of sediment from the runoff (through sedimentation). By interrupting the length of a slope, fiber rolls can also reduce sheet and rill erosion until vegetation is established.

Suitable Applications

Fiber rolls may be suitable:

- Along the toe, top, face, and at grade breaks of exposed and erodible slopes to shorten slope length and spread runoff as sheet flow.
- At the end of a downward slope where it transitions to a steeper slope.
- Along the perimeter of a project.
- As check dams in unlined ditches with minimal grade.
- Down-slope of exposed soil areas.
- At operational storm drains as a form of inlet protection.

Categories

EC	Erosion Control	<input checked="" type="checkbox"/>
SE	Sediment Control	<input checked="" type="checkbox"/>
TC	Tracking Control	
WE	Wind Erosion Control	
NS	Non-Stormwater Management Control	
WM	Waste Management and Materials Pollution Control	

Legend:

- Primary Category
- Secondary Category

Targeted Constituents

Sediment	<input checked="" type="checkbox"/>
Nutrients	
Trash	
Metals	
Bacteria	
Oil and Grease	
Organics	

Potential Alternatives

- SE-1 Silt Fence
- SE-6 Gravel Bag Berm
- SE-8 Sandbag Barrier
- SE-14 Biofilter Bags



Fiber Rolls

SE-5

- Around temporary stockpiles.

Limitations

- Fiber rolls are not effective unless trenched in and staked.
- Not intended for use in high flow situations.
- Difficult to move once saturated.
- If not properly staked and trenched in, fiber rolls could be transported by high flows.
- Fiber rolls have a very limited sediment capture zone.
- Fiber rolls should not be used on slopes subject to creep, slumping, or landslide.
- Rolls typically function for 12-24 months depending upon local conditions.

Implementation

Fiber Roll Materials

- Fiber rolls should be prefabricated.
- Fiber rolls may come manufactured containing polyacrylamide (PAM), a flocculating agent within the roll. Fiber rolls impregnated with PAM provide additional sediment removal capabilities and should be used in areas with fine, clayey or silty soils to provide additional sediment removal capabilities. Monitoring may be required for these installations.
- Fiber rolls are made from weed free rice straw, flax, or a similar agricultural material bound into a tight tubular roll by netting.
- Typical fiber rolls vary in diameter from 9 in. to 20 in. Larger diameter rolls are available as well.

Installation

- Locate fiber rolls on level contours spaced as follows:
 - Slope inclination of 4:1 (H:V) or flatter: Fiber rolls should be placed at a maximum interval of 20 ft.
 - Slope inclination between 4:1 and 2:1 (H:V): Fiber Rolls should be placed at a maximum interval of 15 ft. (a closer spacing is more effective).
 - Slope inclination 2:1 (H:V) or greater: Fiber Rolls should be placed at a maximum interval of 10 ft. (a closer spacing is more effective).
- Prepare the slope before beginning installation.
- Dig small trenches across the slope on the contour. The trench depth should be 1/4 to 1/3 of the thickness of the roll, and the width should equal the roll diameter, in order to provide area to backfill the trench.

Fiber Rolls

SE-5

- It is critical that rolls are installed perpendicular to water movement, and parallel to the slope contour.
- Start building trenches and installing rolls from the bottom of the slope and work up.
- It is recommended that pilot holes be driven through the fiber roll. Use a straight bar to drive holes through the roll and into the soil for the wooden stakes.
- Turn the ends of the fiber roll up slope to prevent runoff from going around the roll.
- Stake fiber rolls into the trench.
 - Drive stakes at the end of each fiber roll and spaced 4 ft maximum on center.
 - Use wood stakes with a nominal classification of 0.75 by 0.75 in. and minimum length of 24 in.
- If more than one fiber roll is placed in a row, the rolls should be overlapped, not abutted.
- See typical fiber roll installation details at the end of this fact sheet.

Removal

- Fiber rolls can be left in place or removed depending on the type of fiber roll and application (temporary vs. permanent installation). Typically, fiber rolls encased with plastic netting are used for a temporary application because the netting does not biodegrade. Fiber rolls used in a permanent application are typically encased with a biodegradable material and are left in place. Removal of a fiber roll used in a permanent application can result in greater disturbance.
- Temporary installations should only be removed when up gradient areas are stabilized per General Permit requirements, and/or pollutant sources no longer present a hazard. But, they should also be removed before vegetation becomes too mature so that the removal process does not disturb more soil and vegetation than is necessary.

Costs

Material costs for regular fiber rolls range from \$20 - \$30 per 25 ft roll.

Material costs for PAM impregnated fiber rolls range between 7.00-\$9.00 per linear foot, based upon vendor research.

Inspection and Maintenance

- BMPs must be inspected in accordance with General Permit requirements for the associated project type and risk level. It is recommended that at a minimum, BMPs be inspected weekly, prior to forecasted rain events, daily during extended rain events, and after the conclusion of rain events.
- Repair or replace split, torn, unraveling, or slumping fiber rolls.
- If the fiber roll is used as a sediment capture device, or as an erosion control device to maintain sheet flows, sediment that accumulates in the BMP should be periodically removed

Fiber Rolls

SE-5

in order to maintain BMP effectiveness. Sediment should be removed when sediment accumulation reaches one-third the designated sediment storage depth.

- If fiber rolls are used for erosion control, such as in a check dam, sediment removal should not be required as long as the system continues to control the grade. Sediment control BMPs will likely be required in conjunction with this type of application.
- Repair any rills or gullies promptly.

References

Stormwater Quality Handbooks - Construction Site Best Management Practices (BMPs) Manual, State of California Department of Transportation (Caltrans), March 2003.

Erosion and Sediment Control Manual, Oregon Department of Environmental Quality, February 2005.

Fiber Rolls

SE-5

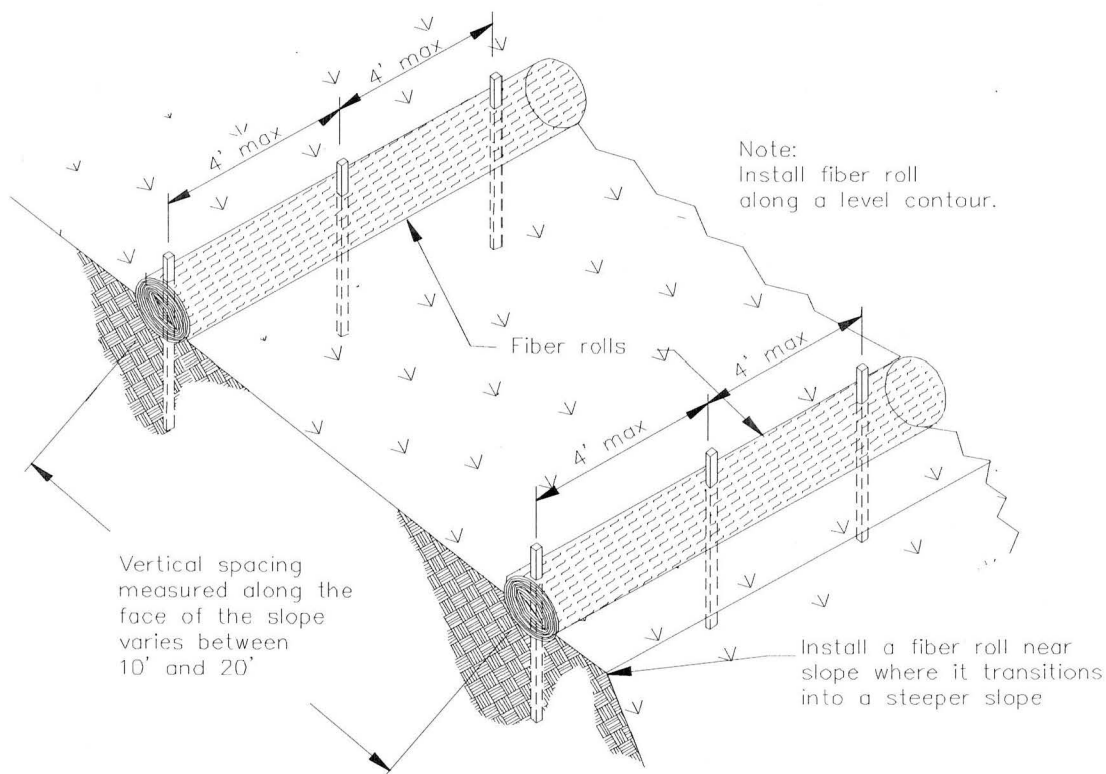

TYPICAL FIBER ROLL INSTALLATION

N.T.S.

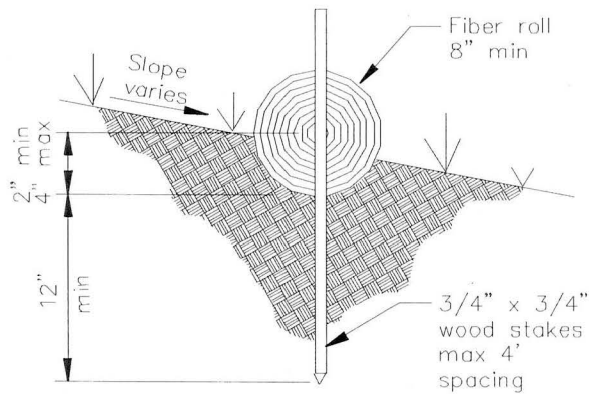

ENTRENCHMENT DETAIL

N.T.S.

Hydraulic Mulch

EC-3

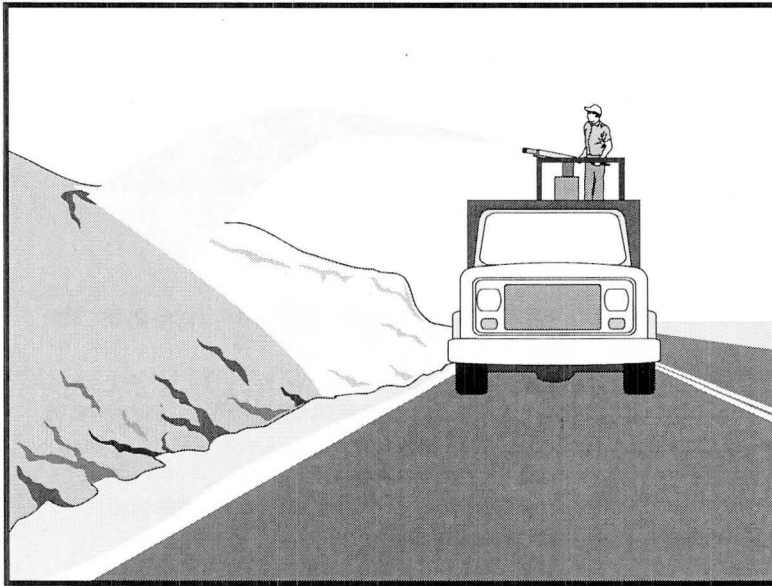

Categories

EC	Erosion Control	<input checked="" type="checkbox"/>
SE	Sediment Control	
TC	Tracking Control	
WE	Wind Erosion Control	<input checked="" type="checkbox"/>
NS	Non-Stormwater Management Control	
WM	Waste Management and Materials Pollution Control	

Legend:

- Primary Category
- Secondary Category

Targeted Constituents

Sediment	<input checked="" type="checkbox"/>
Nutrients	
Trash	
Metals	
Bacteria	
Oil and Grease	
Organics	

Potential Alternatives

- EC-4 Hydroseeding
- EC-5 Soil Binders
- EC-6 Straw Mulch
- EC-7 Geotextiles and Mats
- EC-8 Wood Mulching
- EC-14 Compost Blanket
- EC-16 Non-Vegetative Stabilization

Description and Purpose

Hydraulic Mulch consists of various types of fibrous materials mixed with water and sprayed onto the soil surface in slurry form to provide a layer of temporary protection from wind and water erosion.

Suitable Applications

Hydraulic mulch as a temporary, stand alone, erosion control BMP is suitable for disturbed areas that require temporary protection from wind and water erosion until permanent soil stabilization activities commence. Examples include:

- Rough-graded areas that will remain inactive for longer than permit-required thresholds (e.g., 14 days) or otherwise require stabilization to minimize erosion or prevent sediment discharges.
- Soil stockpiles.
- Slopes with exposed soil between existing vegetation such as trees or shrubs.
- Slopes planted with live, container-grown vegetation or plugs.
- Slopes burned by wildfire.

Hydraulic mulch can also be applied to augment other erosion control BMPs such as:



Hydraulic Mulch

EC-3

- In conjunction with straw mulch (see EC-6 Straw Mulch) where the rate of hydraulic mulch is reduced to 100-500 lbs per acre and the slurry is applied over the straw as a tackifying agent to hold the straw in place.
- Supplemental application of soil amendments, such as fertilizer, lime, gypsum, soil bio-stimulants or compost.

Limitations

In general, hydraulic mulch is not limited by slope length, gradient or soil type. However, the following limitations typically apply:

- Most hydraulic mulch applications, particularly bonded fiber matrices (BFMs), require at least 24 hours to dry before rainfall occurs.
- Temporary applications (i.e., without a vegetative component) may require a second application in order to remain effective for an entire rainy season.
- Treatment areas must be accessible to hydraulic mulching equipment.
- Availability of water sources in remote areas for mixing and application.
- As a stand-alone temporary BMP, hydraulic mulches may need to be re-applied to maintain their erosion control effectiveness, typically after 6-12 months depending on the type of mulch used.
- Availability of hydraulic mulching equipment may be limited just prior to the rainy season and prior to storms due to high demand.
- Cellulose fiber mulches alone may not perform well on steep slopes or in coarse soils.

Implementation

- Where feasible, it is preferable to prepare soil surfaces prior to application by roughening embankments and fill areas with a crimping or punching type roller or by track walking.
- The majority of hydraulic mulch applications do not necessarily require surface/soil preparation (See EC-15 Soil Preparation) although in almost every case where re-vegetation is included as part of the practice, soil preparation can be beneficial. One of the advantages of hydraulic mulch over other erosion control methods is that it can be applied in areas where soil preparation is precluded by site conditions, such as steep slopes, rocky soils, or inaccessibility.
- Avoid mulch over spray onto roads, sidewalks, drainage channels, existing vegetation, etc.
- Hydraulic mulching is generally performed utilizing specialized machines that have a large water-holding/mixing tank and some form of mechanical agitation or other recirculation method to keep water, mulch and soil amendments in suspension. The mixed hydraulic slurry can be applied from a tower sprayer on top of the machine or by extending a hose to areas remote from the machine.

Hydraulic Mulch

EC-3

- Where possible apply hydraulic mulch from multiple directions to adequately cover the soil. Application from a single direction can result in shadowing, uneven coverage and failure of the BMP.
- Hydraulic mulch can also include a vegetative component, such as seed, rhizomes, or stolons (see EC-4 Hydraulic Seed).
- Typical hydraulic mulch application rates range from 2,000 pounds per acre for standard mulches (SMs) to 3,500 pounds per acre for BFMs. However, the required amount of hydraulic mulch to provide adequate coverage of exposed topsoil may appear to exceed the standard rates when the roughness of the soil surface is changed due to soil preparation methods (see EC-15 Soil Preparation) or by slope gradient.
- Other factors such as existing soil moisture and soil texture can have a profound effect on the amount of hydraulic mulch required (i.e. application rate) applied to achieve an erosion-resistant covering.
- Avoid use of mulch without a tackifier component, especially on slopes.
- Mulches used in the hydraulic mulch slurry can include:
 - Cellulose fiber
 - Thermally-processed wood fibers
 - Cotton
 - Synthetics
 - Compost (see EC-14, Compost Blanket)
- Additional guidance on the comparison and selection of temporary slope stabilization methods is provided in Appendix F of the Handbook.

Categories of Hydraulic Mulches

Standard Hydraulic Mulch (SM)

Standard hydraulic mulches are generally applied at a rate of 2,000 pounds per acre and are manufactured containing around 5% tackifier (i.e. soil binder), usually a plant-derived guar or psyllium type. Most standard mulches are green in color derived from food-color based dyes.

Hydraulic Matrices (HM) and Stabilized Fiber Matrices (SFM)

Hydraulic matrices and stabilized fiber matrices are slurries which contain increased levels of tackifiers/soil binders; usually 10% or more by weight. HMs and SFMs have improved performance compared to a standard hydraulic mulch (SM) because of the additional percentage of tackifier and because of their higher application rates, typically 2,500 – 4,000 pounds per acre. Hydraulic matrices can include a mixture of fibers, for example, a 50/50 blend of paper and wood fiber. In the case of an SFM, the tackifier/soil binder is specified as a polyacrylamide (PAM).

Hydraulic Mulch

EC-3

weekly, prior to forecasted rain events, daily during extended rain events, and after the conclusion of rain events.

- Areas where erosion is evident should be repaired and BMPs re-applied as soon as possible. Care should be exercised to minimize the damage to protected areas while making repairs, as any area damaged will require re-application of BMPs.
- Compare the number of bags or weight of applied mulch to the area treated to determine actual application rates and compliance with specifications.

References

Soil Stabilization BMP Research for Erosion and Sediment Controls: Cost Survey Technical Memorandum, State of California Department of Transportation (Caltrans), July 2007.

Controlling Erosion of Construction Sites, Agriculture Information #347, U.S. Department of Agriculture (USDA), Natural Resources Conservation Service (NRCS) (formerly Soil Conservation Service – SCS).

Guides for Erosion and Sediment Control in California, USDA Soils Conservation Service, January 1991.

Manual of Standards of Erosion and Sediment Control Measures, Association of Bay Area Governments, May 1995.

Sedimentation and Erosion Control, An Inventory of Current Practices Draft, US EPA, April 1990.

Soil Erosion by Water, Agriculture Information Bulletin #513, U.S. Department of Agriculture, Soil Conservation Service.

Stormwater Quality Handbooks Construction Site Best Management Practices (BMPs) Manual, State of California Department of Transportation (Caltrans), March 2003.

Guidance Document: Soil Stabilization for Temporary Slopes, State of California Department of Transportation (Caltrans), November 1999

Stormwater Management of the Puget Sound Basin, Technical Manual, Publication #91-75, Washington State Department of Ecology, February 1992.

Water Quality Management Plan for the Lake Tahoe Region, Volume II, Handbook of Management Practices, Tahoe Regional Planning Agency, November 1988.

Violation No. 2

Failure to Implement Material Stockpile BMPs
(10 days)

Fiber Rolls

SE-5

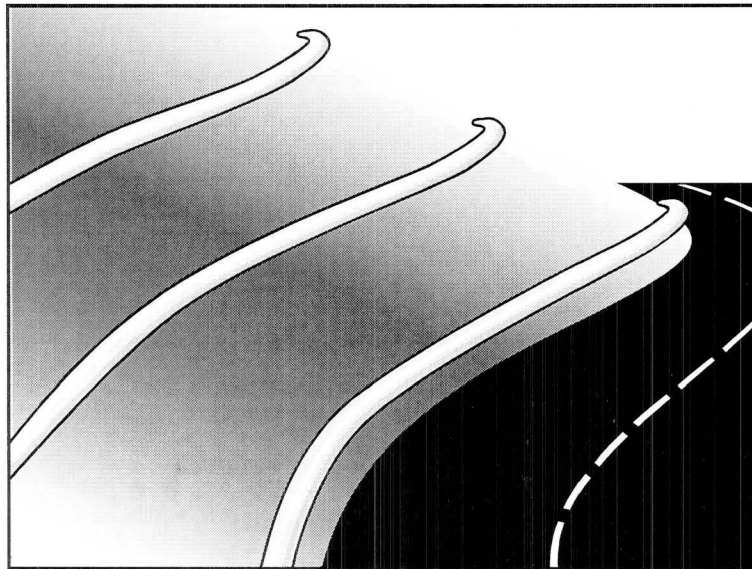

Description and Purpose

A fiber roll consists of straw, coir, or other biodegradable materials bound into a tight tubular roll wrapped by netting, which can be photodegradable or natural. Additionally, gravel core fiber rolls are available, which contain an imbedded ballast material such as gravel or sand for additional weight when staking the rolls are not feasible (such as use as inlet protection). When fiber rolls are placed at the toe and on the face of slopes along the contours, they intercept runoff, reduce its flow velocity, release the runoff as sheet flow, and provide removal of sediment from the runoff (through sedimentation). By interrupting the length of a slope, fiber rolls can also reduce sheet and rill erosion until vegetation is established.

Suitable Applications

Fiber rolls may be suitable:

- Along the toe, top, face, and at grade breaks of exposed and erodible slopes to shorten slope length and spread runoff as sheet flow.
- At the end of a downward slope where it transitions to a steeper slope.
- Along the perimeter of a project.
- As check dams in unlined ditches with minimal grade.
- Down-slope of exposed soil areas.
- At operational storm drains as a form of inlet protection.

Categories

EC	Erosion Control	<input checked="" type="checkbox"/>
SE	Sediment Control	<input checked="" type="checkbox"/>
TC	Tracking Control	
WE	Wind Erosion Control	
NS	Non-Stormwater Management Control	
WM	Waste Management and Materials Pollution Control	

Legend:

- Primary Category
- Secondary Category

Targeted Constituents

Sediment	<input checked="" type="checkbox"/>
Nutrients	
Trash	
Metals	
Bacteria	
Oil and Grease	
Organics	

Potential Alternatives

- SE-1 Silt Fence
- SE-6 Gravel Bag Berm
- SE-8 Sandbag Barrier
- SE-14 Biofilter Bags



Fiber Rolls

SE-5

- Around temporary stockpiles.

Limitations

- Fiber rolls are not effective unless trenched in and staked.
- Not intended for use in high flow situations.
- Difficult to move once saturated.
- If not properly staked and trenched in, fiber rolls could be transported by high flows.
- Fiber rolls have a very limited sediment capture zone.
- Fiber rolls should not be used on slopes subject to creep, slumping, or landslide.
- Rolls typically function for 12-24 months depending upon local conditions.

Implementation

Fiber Roll Materials

- Fiber rolls should be prefabricated.
- Fiber rolls may come manufactured containing polyacrylamide (PAM), a flocculating agent within the roll. Fiber rolls impregnated with PAM provide additional sediment removal capabilities and should be used in areas with fine, clayey or silty soils to provide additional sediment removal capabilities. Monitoring may be required for these installations.
- Fiber rolls are made from weed free rice straw, flax, or a similar agricultural material bound into a tight tubular roll by netting.
- Typical fiber rolls vary in diameter from 9 in. to 20 in. Larger diameter rolls are available as well.

Installation

- Locate fiber rolls on level contours spaced as follows:
 - Slope inclination of 4:1 (H:V) or flatter: Fiber rolls should be placed at a maximum interval of 20 ft.
 - Slope inclination between 4:1 and 2:1 (H:V): Fiber Rolls should be placed at a maximum interval of 15 ft. (a closer spacing is more effective).
 - Slope inclination 2:1 (H:V) or greater: Fiber Rolls should be placed at a maximum interval of 10 ft. (a closer spacing is more effective).
- Prepare the slope before beginning installation.
- Dig small trenches across the slope on the contour. The trench depth should be 1/4 to 1/3 of the thickness of the roll, and the width should equal the roll diameter, in order to provide area to backfill the trench.

Fiber Rolls

SE-5

- It is critical that rolls are installed perpendicular to water movement, and parallel to the slope contour.
- Start building trenches and installing rolls from the bottom of the slope and work up.
- It is recommended that pilot holes be driven through the fiber roll. Use a straight bar to drive holes through the roll and into the soil for the wooden stakes.
- Turn the ends of the fiber roll up slope to prevent runoff from going around the roll.
- Stake fiber rolls into the trench.
 - Drive stakes at the end of each fiber roll and spaced 4 ft maximum on center.
 - Use wood stakes with a nominal classification of 0.75 by 0.75 in. and minimum length of 24 in.
- If more than one fiber roll is placed in a row, the rolls should be overlapped, not abutted.
- See typical fiber roll installation details at the end of this fact sheet.

Removal

- Fiber rolls can be left in place or removed depending on the type of fiber roll and application (temporary vs. permanent installation). Typically, fiber rolls encased with plastic netting are used for a temporary application because the netting does not biodegrade. Fiber rolls used in a permanent application are typically encased with a biodegradable material and are left in place. Removal of a fiber roll used in a permanent application can result in greater disturbance.
- Temporary installations should only be removed when up gradient areas are stabilized per General Permit requirements, and/or pollutant sources no longer present a hazard. But, they should also be removed before vegetation becomes too mature so that the removal process does not disturb more soil and vegetation than is necessary.

Costs

Material costs for regular fiber rolls range from \$20 - \$30 per 25 ft roll.

Material costs for PAM impregnated fiber rolls range between 7.00-\$9.00 per linear foot, based upon vendor research.

Inspection and Maintenance

- BMPs must be inspected in accordance with General Permit requirements for the associated project type and risk level. It is recommended that at a minimum, BMPs be inspected weekly, prior to forecasted rain events, daily during extended rain events, and after the conclusion of rain events.
- Repair or replace split, torn, unraveling, or slumping fiber rolls.
- If the fiber roll is used as a sediment capture device, or as an erosion control device to maintain sheet flows, sediment that accumulates in the BMP should be periodically removed

Fiber Rolls

SE-5

in order to maintain BMP effectiveness. Sediment should be removed when sediment accumulation reaches one-third the designated sediment storage depth.

- If fiber rolls are used for erosion control, such as in a check dam, sediment removal should not be required as long as the system continues to control the grade. Sediment control BMPs will likely be required in conjunction with this type of application.
- Repair any rills or gullies promptly.

References

Stormwater Quality Handbooks - Construction Site Best Management Practices (BMPs) Manual, State of California Department of Transportation (Caltrans), March 2003.

Erosion and Sediment Control Manual, Oregon Department of Environmental Quality, February 2005.

Fiber Rolls

SE-5

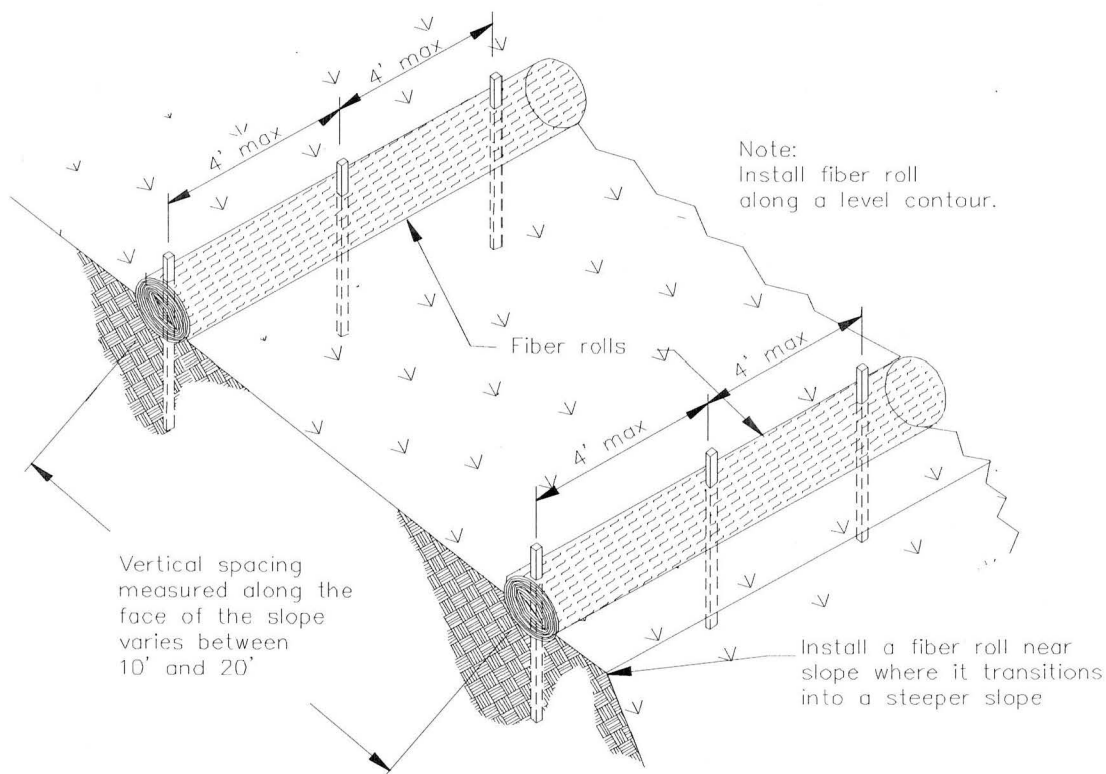

TYPICAL FIBER ROLL INSTALLATION

N.T.S.

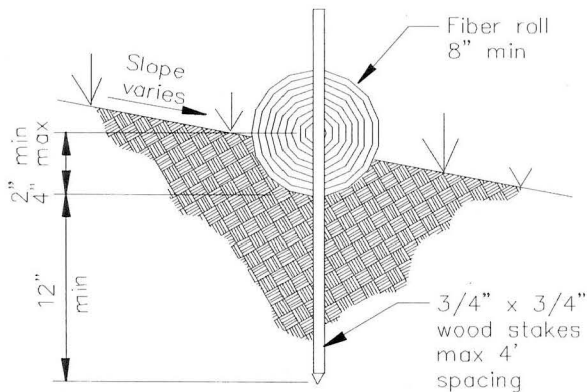

ENTRENCHMENT DETAIL

N.T.S.



Select Your Store

Help Center | Services | Credit Center | Gift Cards

Departments | Project Center | Promotions | Search All

Search bar with magnifying glass icon and Cart (0)

Home > Paint > Drop Cloths & Plastic Sheeting > Poly Film



Polar Plastics 6-Mil Clear Poly Reinforced Plastic Sheeting - 20' x 50' Roll

Model Number: 5680090 | Menards® SKU: 5680090
Variation: Clear

Online Price **\$74.98**



Online Availability

- Ship to Home
Available for immediate shipment
- Ship to Store - Free!

Quantity

Add to Cart

Add to My List

Description

- Add to Compare
- Add to Gift Registry

Click image for a larger view.
Hover to zoom in.

Store Availability

Enter Your ZIP Code for Store Information

Description & Documents

For everything from simple dust protection to heavy-duty construction projects, Polar Plastics has a fitting solution. Their strong, durable plastics come in a variety of sizes, thicknesses and colors to perfectly meet the requirements of your project. This reinforced sheeting is the epitome of strength when it comes to plastic sheeting. With two layers of low-density polyethylene and hundreds of nylon strings forming a diamond scrim pattern, this sheeting makes a great long-term cover for heavy-duty equipment or the perfect dust and debris shield. Use as much or as little as you need!

- Two layers of low-density polyethylene with nylon strings running through and between
- Reinforced diamond scrim pattern is ideal for heavy-duty applications
- Commonly used for building enclosures, crawl spaces and as a long-lasting equipment cover
- Reinforced design stops tears and punctures
- Perfect for weather, water and dust protection
- Made in USA
- 6-mil thickness is the nominal size

Dimensions: 20' x 50'



MSDS Document: [101025_001.pdf](#) [106044_001.pdf](#)

To read PDF files, you need the Adobe Acrobat Reader 6.0 or higher. If you don't have it, [click here](#) and download it for free from Adobe's site.

Guests Who Viewed This Item Also Viewed These Products



Polar Plastics 6-Mil Clear Poly All-Purpose Plastic Sheeting - 20' x 100' Roll

\$72.98



Polar Plastics 6-Mil Clear Poly Reinforced Plastic Sheeting - 12' x 100' Roll

\$84.98

Please Note: Prices, promotions, styles and availability may vary by store and online. While we do our best to provide accurate item availability information, we cannot guarantee in-stock status and availability as inventory is sold and received continuously throughout the day. Inventory last updated 8/17/2015 at 5:00am EST. Online orders and products purchased in-store qualify for rebate redemption. Rebates are provided in the form of a merchandise credit check which can only be used in a Menards® store.

Violation No. 3

Failure to Implement Vehicle Fluid Leak BMPs
(2 days)



[Print this page](#) [Email this page](#) [Add to Favorites](#)

Drip Pillow Berm™

Capture small leaks and drips easily



Have a small leak, drip or spill? Our Drip Pillow Berm comes in four sizes to capture small leaks and drips and with its stable weighted base, it will not tip or splash in windy conditions if used outdoors. Grommets in the corners provide attachment points. Eliminates nuisance drips under vehicles, hydraulic lines or equipment.

Weighted unit can withstand up to 40 mph winds

Folds easy for storage or transport

Measures 38"L x 42"W x 3"H

Absorbs 4 gallons

Weighs 7 lbs

[View Larger](#)



Select Product

Drip Pillow Berm™						
Preview	Item Number	Description	Units	Price Per Unit		QTY
	BERM404	Drip Pillow Berm	Each	1+ \$300.00	4+ \$257.14	<input type="text"/> In Stock

Violation No. 4

Failure to Implement Erosion Control BMPs in
Inactive Areas
(22 days)

Sandbag Barrier

SE-8

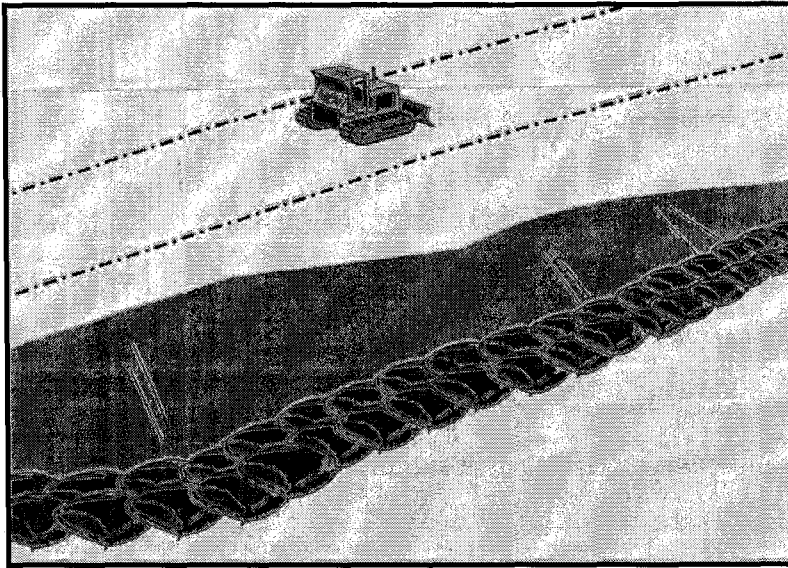

Categories

EC	Erosion Control	<input checked="" type="checkbox"/>
SE	Sediment Control	<input checked="" type="checkbox"/>
TC	Tracking Control	
WE	Wind Erosion Control	
NS	Non-Stormwater Management Control	
WM	Waste Management and Materials Pollution Control	

Legend:

- Primary Category
- Secondary Category

Description and Purpose

A sandbag barrier is a series of sand-filled bags placed on a level contour to intercept or to divert sheet flows. Sandbag barriers placed on a level contour pond sheet flow runoff, allowing sediment to settle out.

Suitable Applications

Sandbag barriers may be suitable:

- As a linear sediment control measure:
 - Below the toe of slopes and erodible slopes.
 - As sediment traps at culvert/pipe outlets.
 - Below other small cleared areas.
 - Along the perimeter of a site.
 - Down slope of exposed soil areas.
 - Around temporary stockpiles and spoil areas.
 - Parallel to a roadway to keep sediment off paved areas.
 - Along streams and channels.
- As linear erosion control measure:
 - Along the face and at grade breaks of exposed and erodible slopes to shorten slope length and spread runoff as sheet flow.

Targeted Constituents

Sediment	<input checked="" type="checkbox"/>
Nutrients	
Trash	
Metals	
Bacteria	
Oil and Grease	
Organics	

Potential Alternatives

- SE-1 Silt Fence
- SE-5 Fiber Rolls
- SE-6 Gravel Bag Berm
- SE-14 Biofilter Bags

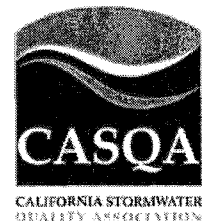

Sandbag Barrier

SE-8

- At the top of slopes to divert runoff away from disturbed slopes.
- As check dams across mildly sloped construction roads.

Limitations

- It is necessary to limit the drainage area upstream of the barrier to 5 acres.
- Sandbags are not intended to be used as filtration devices.
- Easily damaged by construction equipment.
- Degraded sandbags may rupture when removed, spilling sand.
- Sand is easily transported by runoff if bag is damaged or ruptured.
- Installation can be labor intensive.
- Durability of sandbags is somewhat limited and bags may need to be replaced when installation is required for longer than 6 months. When used to detain concentrated flows, maintenance requirements increase.
- Burlap should not be used for sandbags.

Implementation

General

A sandbag barrier consists of a row of sand-filled bags placed on a level contour. When appropriately placed, a sandbag barrier intercepts and slows sheet flow runoff, causing temporary ponding. The temporary ponding allows sediment to settle. Sand-filled bags have limited porosity, which is further limited as the fine sand tends to quickly plug with sediment, limiting or completely blocking the rate of flow through the barrier. If a porous barrier is desired, consider SE-1, Silt Fence, SE-5, Fiber Rolls, SE-6, Gravel Bag Berms or SE-14, Biofilter Bags. Sandbag barriers also interrupt the slope length and thereby reduce erosion by reducing the tendency of sheet flows to concentrate into rivulets which erode rills, and ultimately gullies, into disturbed, sloped soils. Sandbag barriers are similar to gravel bag berms, but less porous. Generally, sandbag barriers should be used in conjunction with temporary soil stabilization controls up slope to provide effective erosion and sediment control.

Design and Layout

- Locate sandbag barriers on a level contour.
- When used for slope interruption, the following slope/sheet flow length combinations apply:
 - Slope inclination of 4:1 (H:V) or flatter: Sandbags should be placed at a maximum interval of 20 ft, with the first row near the slope toe.
 - Slope inclination between 4:1 and 2:1 (H:V): Sandbags should be placed at a maximum interval of 15 ft. (a closer spacing is more effective), with the first row near the slope toe.
 - Slope inclination 2:1 (H:V) or greater: Sandbags should be placed at a maximum interval of 10 ft. (a closer spacing is more effective), with the first row near the slope toe.

Sandbag Barrier

SE-8

- Turn the ends of the sandbag barrier up slope to prevent runoff from going around the barrier.
- Allow sufficient space up slope from the barrier to allow ponding, and to provide room for sediment storage.
- For installation near the toe of the slope, sand bag barriers should be set back from the slope toe to facilitate cleaning. Where specific site conditions do not allow for a set-back, the sand bag barrier may be constructed on the toe of the slope. To prevent flows behind the barrier, bags can be placed perpendicular to a berm to serve as cross barriers.
- Drainage area should not exceed 5 acres.
- Stack sandbags at least three bags high.
- Butt ends of bags tightly.
- Overlap butt joints of row beneath with each successive row.
- Use a pyramid approach when stacking bags.
- In non-traffic areas
 - Height = 18 in. maximum
 - Top width = 24 in. minimum for three or more layer construction
 - Side slope = 2:1 (H:V) or flatter
- In construction traffic areas
 - Height = 12 in. maximum
 - Top width = 24 in. minimum for three or more layer construction.
 - Side slopes = 2:1 (H:V) or flatter.
- See typical sandbag barrier installation details at the end of this fact sheet.

Materials

- **Sandbag Material:** Sandbag should be woven polypropylene, polyethylene or polyamide fabric, minimum unit weight of 4 ounces/yd², Mullen burst strength exceeding 300 lb/in² in conformance with the requirements in ASTM designation D3786, and ultraviolet stability exceeding 70% in conformance with the requirements in ASTM designation D4355. Use of burlap is not an acceptable substitute, as sand can more easily mobilize out of burlap.
- **Sandbag Size:** Each sand-filled bag should have a length of 18 in., width of 12 in., thickness of 3 in., and mass of approximately 33 lbs. Bag dimensions are nominal, and may vary based on locally available materials.

Sandbag Barrier

SE-8

- **Fill Material:** All sandbag fill material should be non-cohesive, Class 3 (Caltrans Standard Specification, Section 25) permeable material free from clay and deleterious material, such as recycled concrete or asphalt..

Costs

Empty sandbags cost \$0.25 - \$0.75. Average cost of fill material is \$8 per yd³. Additional labor is required to fill the bags. Pre-filled sandbags are more expensive at \$1.50 - \$2.00 per bag. These costs are based upon vendor research.

Inspection and Maintenance

- BMPs must be inspected in accordance with General Permit requirements for the associated project type and risk level. It is recommended that at a minimum, BMPs be inspected weekly, prior to forecasted rain events, daily during extended rain events, and after the conclusion of rain events.
- Sandbags exposed to sunlight will need to be replaced every two to three months due to degradation of the bags.
- Reshape or replace sandbags as needed.
- Repair washouts or other damage as needed.
- Sediment that accumulates behind the BMP should be periodically removed in order to maintain BMP effectiveness. Sediment should be removed when the sediment accumulation reaches one-third of the barrier height.
- Remove sandbags when no longer needed and recycle sand fill whenever possible and properly dispose of bag material. Remove sediment accumulation, and clean, re-grade, and stabilize the area.

References

Standard Specifications for Construction of Local Streets and Roads, California Department of Transportation (Caltrans), July 2002.

Stormwater Quality Handbooks - Construction Site Best Management Practices (BMPs) Manual, State of California Department of Transportation (Caltrans), March 2003.

Erosion and Sediment Control Manual, Oregon Department of Environmental Quality, February 2005.

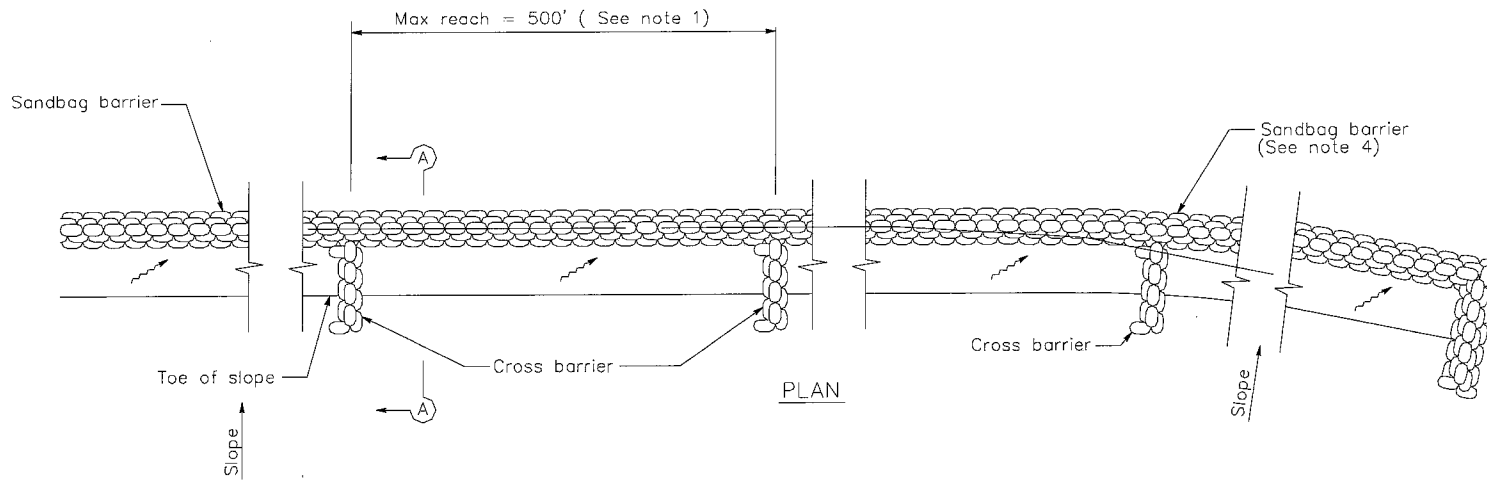

SANDBAG BARRIER

NOTES

1. Construct the length of each reach so that the change in base elevation along the reach does not exceed $1/2$ the height of the linear barrier. In no case shall the reach length exceed 500'.
2. Place sandbags tightly.
3. Dimension may vary to fit field condition.
4. Sandbag barrier shall be a minimum of 3 bags high.
5. The end of the barrier shall be turned up slope.
6. Cross barriers shall be a min of $1/2$ and a max of $2/3$ the height of the linear barrier.
7. Sandbag rows and layers shall be staggered to eliminate gaps.

Sandbag Barrier

SE-8

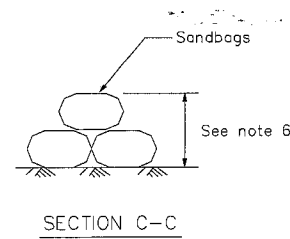
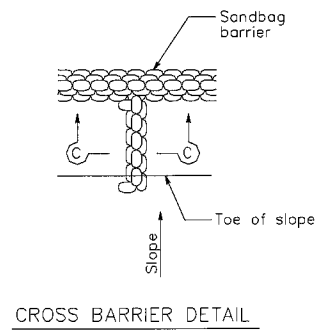
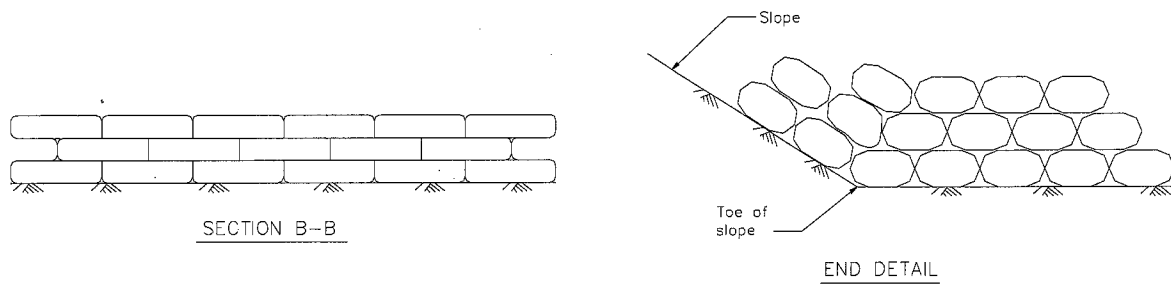
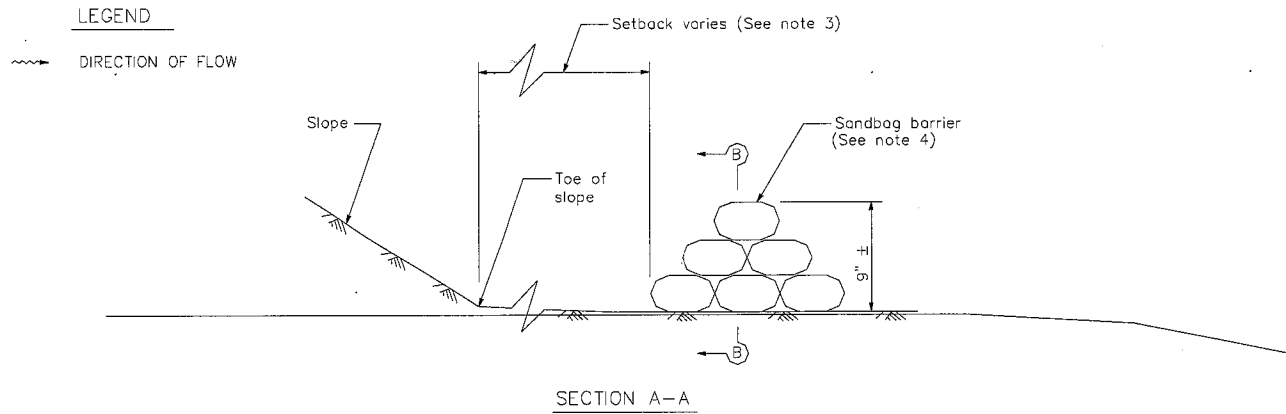

Hydraulic Mulch

EC-3

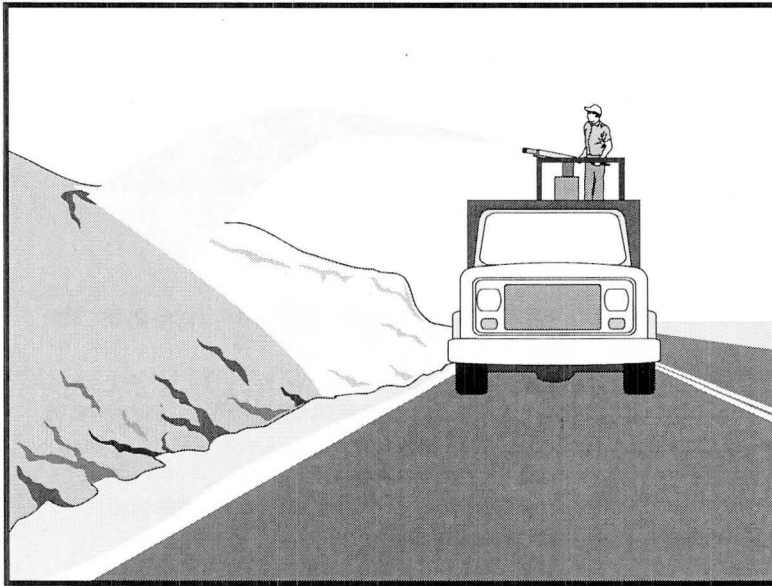

Categories

EC	Erosion Control	<input checked="" type="checkbox"/>
SE	Sediment Control	
TC	Tracking Control	
WE	Wind Erosion Control	<input checked="" type="checkbox"/>
NS	Non-Stormwater Management Control	
WM	Waste Management and Materials Pollution Control	

Legend:

- Primary Category
- Secondary Category

Targeted Constituents

Sediment	<input checked="" type="checkbox"/>
Nutrients	
Trash	
Metals	
Bacteria	
Oil and Grease	
Organics	

Potential Alternatives

- EC-4 Hydroseeding
- EC-5 Soil Binders
- EC-6 Straw Mulch
- EC-7 Geotextiles and Mats
- EC-8 Wood Mulching
- EC-14 Compost Blanket
- EC-16 Non-Vegetative Stabilization

Description and Purpose

Hydraulic Mulch consists of various types of fibrous materials mixed with water and sprayed onto the soil surface in slurry form to provide a layer of temporary protection from wind and water erosion.

Suitable Applications

Hydraulic mulch as a temporary, stand alone, erosion control BMP is suitable for disturbed areas that require temporary protection from wind and water erosion until permanent soil stabilization activities commence. Examples include:

- Rough-graded areas that will remain inactive for longer than permit-required thresholds (e.g., 14 days) or otherwise require stabilization to minimize erosion or prevent sediment discharges.
- Soil stockpiles.
- Slopes with exposed soil between existing vegetation such as trees or shrubs.
- Slopes planted with live, container-grown vegetation or plugs.
- Slopes burned by wildfire.

Hydraulic mulch can also be applied to augment other erosion control BMPs such as:



Hydraulic Mulch

EC-3

- In conjunction with straw mulch (see EC-6 Straw Mulch) where the rate of hydraulic mulch is reduced to 100-500 lbs per acre and the slurry is applied over the straw as a tackifying agent to hold the straw in place.
- Supplemental application of soil amendments, such as fertilizer, lime, gypsum, soil bio-stimulants or compost.

Limitations

In general, hydraulic mulch is not limited by slope length, gradient or soil type. However, the following limitations typically apply:

- Most hydraulic mulch applications, particularly bonded fiber matrices (BFMs), require at least 24 hours to dry before rainfall occurs.
- Temporary applications (i.e., without a vegetative component) may require a second application in order to remain effective for an entire rainy season.
- Treatment areas must be accessible to hydraulic mulching equipment.
- Availability of water sources in remote areas for mixing and application.
- As a stand-alone temporary BMP, hydraulic mulches may need to be re-applied to maintain their erosion control effectiveness, typically after 6-12 months depending on the type of mulch used.
- Availability of hydraulic mulching equipment may be limited just prior to the rainy season and prior to storms due to high demand.
- Cellulose fiber mulches alone may not perform well on steep slopes or in coarse soils.

Implementation

- Where feasible, it is preferable to prepare soil surfaces prior to application by roughening embankments and fill areas with a crimping or punching type roller or by track walking.
- The majority of hydraulic mulch applications do not necessarily require surface/soil preparation (See EC-15 Soil Preparation) although in almost every case where re-vegetation is included as part of the practice, soil preparation can be beneficial. One of the advantages of hydraulic mulch over other erosion control methods is that it can be applied in areas where soil preparation is precluded by site conditions, such as steep slopes, rocky soils, or inaccessibility.
- Avoid mulch over spray onto roads, sidewalks, drainage channels, existing vegetation, etc.
- Hydraulic mulching is generally performed utilizing specialized machines that have a large water-holding/mixing tank and some form of mechanical agitation or other recirculation method to keep water, mulch and soil amendments in suspension. The mixed hydraulic slurry can be applied from a tower sprayer on top of the machine or by extending a hose to areas remote from the machine.

Hydraulic Mulch

EC-3

- Where possible apply hydraulic mulch from multiple directions to adequately cover the soil. Application from a single direction can result in shadowing, uneven coverage and failure of the BMP.
- Hydraulic mulch can also include a vegetative component, such as seed, rhizomes, or stolons (see EC-4 Hydraulic Seed).
- Typical hydraulic mulch application rates range from 2,000 pounds per acre for standard mulches (SMs) to 3,500 pounds per acre for BFMs. However, the required amount of hydraulic mulch to provide adequate coverage of exposed topsoil may appear to exceed the standard rates when the roughness of the soil surface is changed due to soil preparation methods (see EC-15 Soil Preparation) or by slope gradient.
- Other factors such as existing soil moisture and soil texture can have a profound effect on the amount of hydraulic mulch required (i.e. application rate) applied to achieve an erosion-resistant covering.
- Avoid use of mulch without a tackifier component, especially on slopes.
- Mulches used in the hydraulic mulch slurry can include:
 - Cellulose fiber
 - Thermally-processed wood fibers
 - Cotton
 - Synthetics
 - Compost (see EC-14, Compost Blanket)
- Additional guidance on the comparison and selection of temporary slope stabilization methods is provided in Appendix F of the Handbook.

Categories of Hydraulic Mulches

Standard Hydraulic Mulch (SM)

Standard hydraulic mulches are generally applied at a rate of 2,000 pounds per acre and are manufactured containing around 5% tackifier (i.e. soil binder), usually a plant-derived guar or psyllium type. Most standard mulches are green in color derived from food-color based dyes.

Hydraulic Matrices (HM) and Stabilized Fiber Matrices (SFM)

Hydraulic matrices and stabilized fiber matrices are slurries which contain increased levels of tackifiers/soil binders; usually 10% or more by weight. HMs and SFMs have improved performance compared to a standard hydraulic mulch (SM) because of the additional percentage of tackifier and because of their higher application rates, typically 2,500 – 4,000 pounds per acre. Hydraulic matrices can include a mixture of fibers, for example, a 50/50 blend of paper and wood fiber. In the case of an SFM, the tackifier/soil binder is specified as a polyacrylamide (PAM).

Hydraulic Mulch

EC-3

Bonded Fiber Matrix (BFM)

Bonded fiber matrices (BFMs) are hydraulically-applied systems of fibers, adhesives (typically guar based) and chemical cross-links. Upon drying, the slurry forms an erosion-resistant blanket that prevents soil erosion and promotes vegetation establishment. The cross-linked adhesive in the BFM should be biodegradable and should not dissolve or disperse upon re-wetting. BFMs are typically applied at rates from 3,000 to 4,000 lbs/acre based on the manufacturer's recommendation. BFMs should not be applied immediately before, during or immediately after rainfall or if the soil is saturated. Depending on the product, BFMs typically require 12 to 24 hours to dry and become effective.

Mechanically-Bonded Fiber Matrices (MBFM)

Mechanically-bonded fiber matrices (MBFMs) are hydraulically applied systems similar to BFM that use crimped synthetic fibers and PAM and are typically applied to a slope at a higher application rate than a standard BFM.

Hydraulic Compost Matrix (HCM)

Hydraulic compost matrix (HCM) is a field-derived practice whereby finely graded or sifted compost is introduced into the hydraulic mulch slurry. A guar-type tackifier can be added for steeper slope applications as well as any specified seed mixtures. A HCM can help to accelerate seed germination and growth. HCMs are particularly useful as an in-fill for three-dimensional re-vegetation geocomposites, such as turf reinforcement mats (TRM) (see EC-7 Geotextiles and Mats).

Costs

Average installed costs for hydraulic mulch categories are is provided in Table 1, below.

Table 1
HYDRAULIC MULCH BMPs
INSTALLED COSTS

BMP	Installed Cost/Acre
Standard Hydraulic Mulching (SM)	\$1,700 - \$3,600 per acre
Hydraulic Matrices (HM) and Stabilized Fiber Matrices	
Guar-based	\$2,000 - \$4,000 per acre
PAM-based	\$2,500 - \$5,610 per acre
Bonded Fiber Matrix (BFM)	\$3,900 - \$6,900 per acre
Mechanically Bonded Fiber Matrix (MBFM)	\$4,500 - \$6,000 per acre
Hydraulic Compost Matrix (HCM)	\$3,000 - \$3,500 per acre

Source: Caltrans Soil Stabilization BMP Research for Erosion and Sediment Controls, July 2007

Inspection and Maintenance

- Maintain an unbroken, temporary mulched ground cover throughout the period of construction when the soils are not being reworked.
- BMPs must be inspected in accordance with General Permit requirements for the associated project type and risk level. It is recommended that at a minimum, BMPs be inspected

Hydraulic Mulch

EC-3

weekly, prior to forecasted rain events, daily during extended rain events, and after the conclusion of rain events.

- Areas where erosion is evident should be repaired and BMPs re-applied as soon as possible. Care should be exercised to minimize the damage to protected areas while making repairs, as any area damaged will require re-application of BMPs.
- Compare the number of bags or weight of applied mulch to the area treated to determine actual application rates and compliance with specifications.

References

Soil Stabilization BMP Research for Erosion and Sediment Controls: Cost Survey Technical Memorandum, State of California Department of Transportation (Caltrans), July 2007.

Controlling Erosion of Construction Sites, Agriculture Information #347, U.S. Department of Agriculture (USDA), Natural Resources Conservation Service (NRCS) (formerly Soil Conservation Service – SCS).

Guides for Erosion and Sediment Control in California, USDA Soils Conservation Service, January 1991.

Manual of Standards of Erosion and Sediment Control Measures, Association of Bay Area Governments, May 1995.

Sedimentation and Erosion Control, An Inventory of Current Practices Draft, US EPA, April 1990.

Soil Erosion by Water, Agriculture Information Bulletin #513, U.S. Department of Agriculture, Soil Conservation Service.

Stormwater Quality Handbooks Construction Site Best Management Practices (BMPs) Manual, State of California Department of Transportation (Caltrans), March 2003.

Guidance Document: Soil Stabilization for Temporary Slopes, State of California Department of Transportation (Caltrans), November 1999

Stormwater Management of the Puget Sound Basin, Technical Manual, Publication #91-75, Washington State Department of Ecology, February 1992.

Water Quality Management Plan for the Lake Tahoe Region, Volume II, Handbook of Management Practices, Tahoe Regional Planning Agency, November 1988.

Violation No. 5

Failure to Implement Perimeter Sediment
Control BMPs
(14 days)

Stabilized Construction Entrance/Exit TC-1

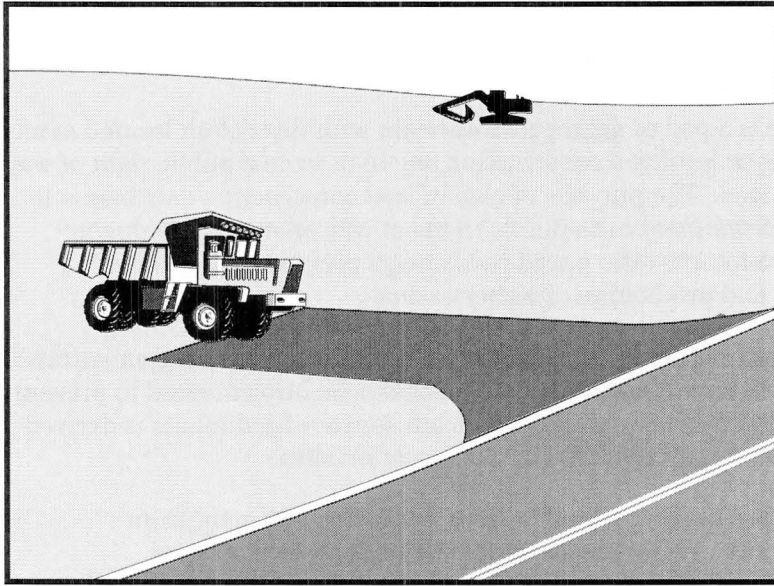

Description and Purpose

A stabilized construction access is defined by a point of entrance/exit to a construction site that is stabilized to reduce the tracking of mud and dirt onto public roads by construction vehicles.

Suitable Applications

Use at construction sites:

- Where dirt or mud can be tracked onto public roads.
- Adjacent to water bodies.
- Where poor soils are encountered.
- Where dust is a problem during dry weather conditions.

Limitations

- Entrances and exits require periodic top dressing with additional stones.
- This BMP should be used in conjunction with street sweeping on adjacent public right of way.
- Entrances and exits should be constructed on level ground only.
- Stabilized construction entrances are rather expensive to construct and when a wash rack is included, a sediment trap of some kind must also be provided to collect wash water runoff.

Categories

EC	Erosion Control	<input checked="" type="checkbox"/>
SE	Sediment Control	<input checked="" type="checkbox"/>
TC	Tracking Control	<input checked="" type="checkbox"/>
WE	Wind Erosion Control	
NS	Non-Stormwater Management Control	
WM	Waste Management and Materials Pollution Control	

Legend:

- Primary Objective
- Secondary Objective

Targeted Constituents

Sediment	<input checked="" type="checkbox"/>
Nutrients	
Trash	
Metals	
Bacteria	
Oil and Grease	
Organics	

Potential Alternatives

None



Stabilized Construction Entrance/Exit TC-1

Implementation

General

A stabilized construction entrance is a pad of aggregate underlain with filter cloth located at any point where traffic will be entering or leaving a construction site to or from a public right of way, street, alley, sidewalk, or parking area. The purpose of a stabilized construction entrance is to reduce or eliminate the tracking of sediment onto public rights of way or streets. Reducing tracking of sediments and other pollutants onto paved roads helps prevent deposition of sediments into local storm drains and production of airborne dust.

Where traffic will be entering or leaving the construction site, a stabilized construction entrance should be used. NPDES permits require that appropriate measures be implemented to prevent tracking of sediments onto paved roadways, where a significant source of sediments is derived from mud and dirt carried out from unpaved roads and construction sites.

Stabilized construction entrances are moderately effective in removing sediment from equipment leaving a construction site. The entrance should be built on level ground. Advantages of the Stabilized Construction Entrance/Exit is that it does remove some sediment from equipment and serves to channel construction traffic in and out of the site at specified locations. Efficiency is greatly increased when a washing rack is included as part of a stabilized construction entrance/exit.

Design and Layout

- Construct on level ground where possible.
- Select 3 to 6 in. diameter stones.
- Use minimum depth of stones of 12 in. or as recommended by soils engineer.
- Construct length of 50 ft or maximum site will allow, and 10 ft minimum width or to accommodate traffic.
- Rumble racks constructed of steel panels with ridges and installed in the stabilized entrance/exit will help remove additional sediment and to keep adjacent streets clean.
- Provide ample turning radii as part of the entrance.
- Limit the points of entrance/exit to the construction site.
- Limit speed of vehicles to control dust.
- Properly grade each construction entrance/exit to prevent runoff from leaving the construction site.
- Route runoff from stabilized entrances/exits through a sediment trapping device before discharge.
- Design stabilized entrance/exit to support heaviest vehicles and equipment that will use it.

Stabilized Construction Entrance/Exit TC-1

- Select construction access stabilization (aggregate, asphaltic concrete, concrete) based on longevity, required performance, and site conditions. Do not use asphalt concrete (AC) grindings for stabilized construction access/roadway.
- If aggregate is selected, place crushed aggregate over geotextile fabric to at least 12 in. depth, or place aggregate to a depth recommended by a geotechnical engineer. A crushed aggregate greater than 3 in. but smaller than 6 in. should be used.
- Designate combination or single purpose entrances and exits to the construction site.
- Require that all employees, subcontractors, and suppliers utilize the stabilized construction access.
- Implement SE-7, Street Sweeping and Vacuuming, as needed.
- All exit locations intended to be used for more than a two-week period should have stabilized construction entrance/exit BMPs.

Inspection and Maintenance

- Inspect and verify that activity-based BMPs are in place prior to the commencement of associated activities. While activities associated with the BMPs are under way, inspect BMPs in accordance with General Permit requirements for the associated project type and risk level. It is recommended that at a minimum, BMPs be inspected weekly, prior to forecasted rain events, daily during extended rain events, and after the conclusion of rain events.
- Inspect local roads adjacent to the site daily. Sweep or vacuum to remove visible accumulated sediment.
- Remove aggregate, separate and dispose of sediment if construction entrance/exit is clogged with sediment.
- Keep all temporary roadway ditches clear.
- Check for damage and repair as needed.
- Replace gravel material when surface voids are visible.
- Remove all sediment deposited on paved roadways within 24 hours.
- Remove gravel and filter fabric at completion of construction

Costs

Average annual cost for installation and maintenance may vary from \$1,200 to \$4,800 each, averaging \$2,400 per entrance. Costs will increase with addition of washing rack, and sediment trap. With wash rack, costs range from \$1,200 - \$6,000 each, averaging \$3,600 per entrance.

References

Manual of Standards of Erosion and Sediment Control Measures, Association of Bay Area Governments, May 1995.

Stabilized Construction Entrance/Exit TC-1

National Management Measures to Control Nonpoint Source Pollution from Urban Areas, USEPA Agency, 2002.

Proposed Guidance Specifying Management Measures for Sources of Nonpoint Pollution in Coastal Waters, Work Group Working Paper, USEPA, April 1992.

Stormwater Quality Handbooks Construction Site Best Management Practices (BMPs) Manual, State of California Department of Transportation (Caltrans), November 2000.

Stormwater Management of the Puget Sound Basin, Technical Manual, Publication #91-75, Washington State Department of Ecology, February 1992.

Virginia Erosion and Sedimentation Control Handbook, Virginia Department of Conservation and Recreation, Division of Soil and Water Conservation, 1991.

Guidance Specifying Management Measures for Nonpoint Pollution in Coastal Waters, EPA 840-B-9-002, USEPA, Office of Water, Washington, DC, 1993.

Water Quality Management Plan for the Lake Tahoe Region, Volume II, Handbook of Management Practices, Tahoe Regional Planning Agency, November 1988.

Stabilized Construction Entrance/Exit TC-1

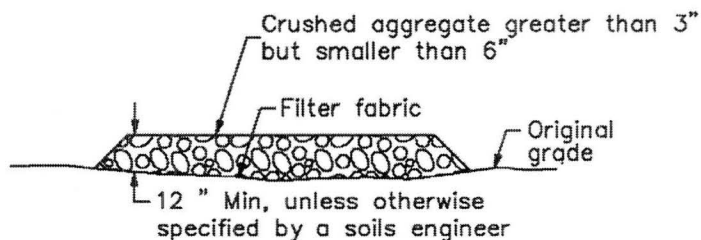

SECTION B-B
NTS

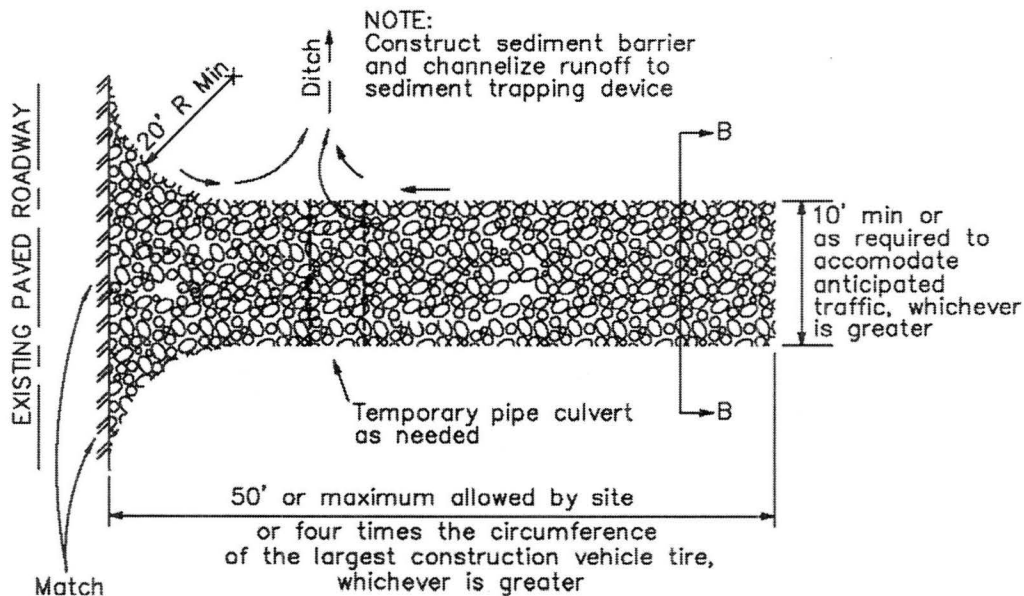

PLAN
NTS

Stabilized Construction Entrance/Exit TC-1

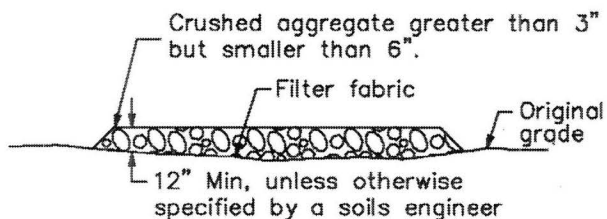

SECTION B-B
 NTS

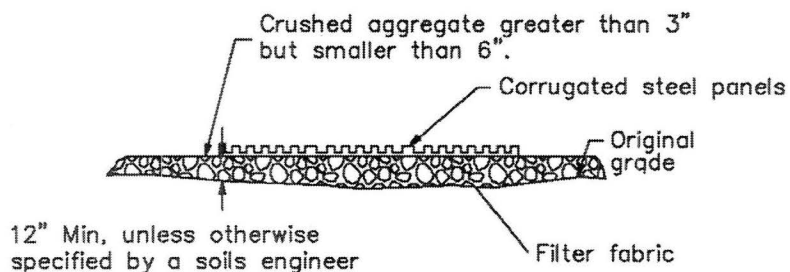

SECTION A-A
 NOT TO SCALE

NOTE:

Construct sediment barrier and channelize runoff to sediment trapping device

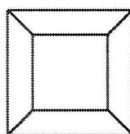

Sediment trapping device

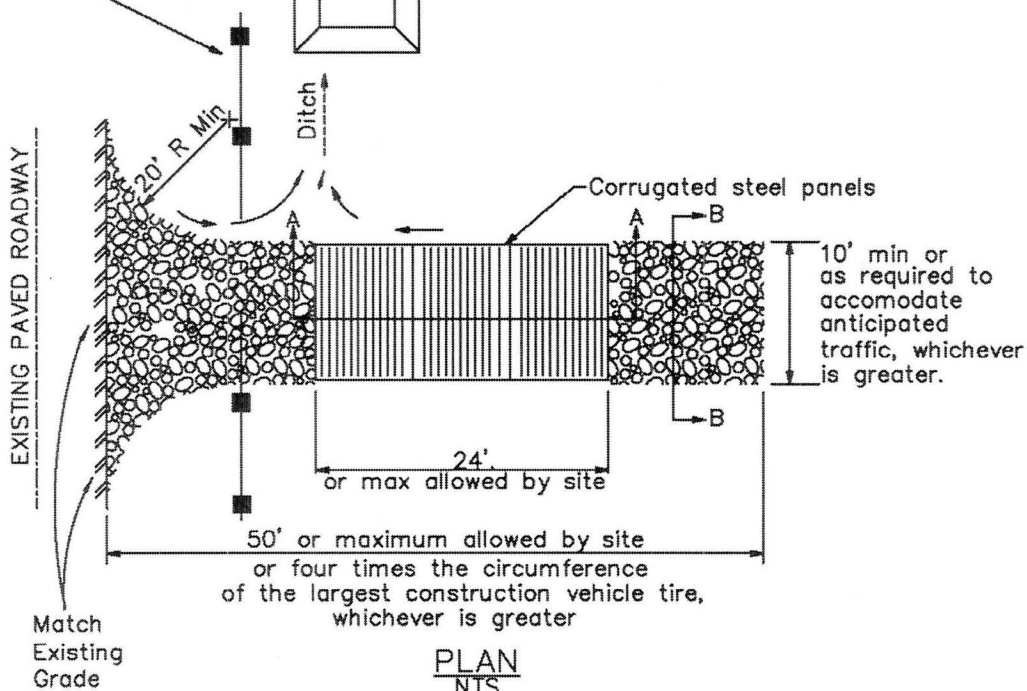

Sandbag Barrier

SE-8

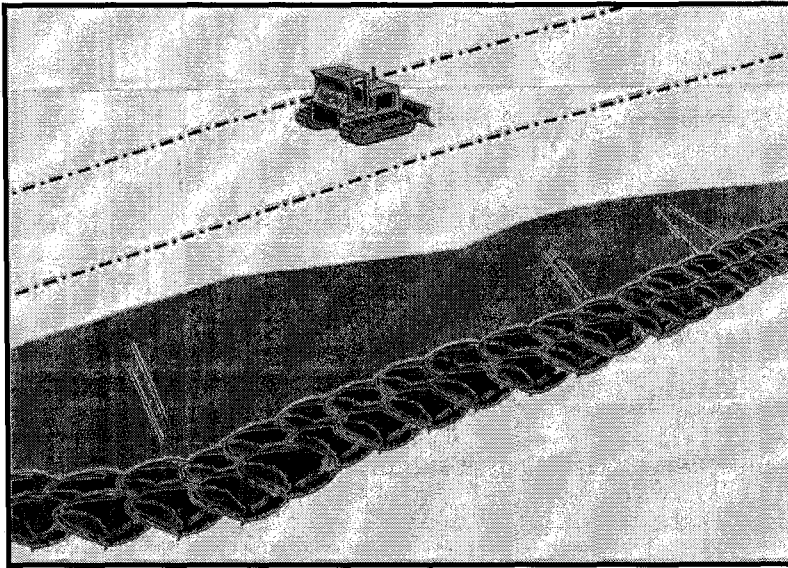

Categories

EC	Erosion Control	<input checked="" type="checkbox"/>
SE	Sediment Control	<input checked="" type="checkbox"/>
TC	Tracking Control	
WE	Wind Erosion Control	
NS	Non-Stormwater Management Control	
WM	Waste Management and Materials Pollution Control	

Legend:

- Primary Category
- Secondary Category

Description and Purpose

A sandbag barrier is a series of sand-filled bags placed on a level contour to intercept or to divert sheet flows. Sandbag barriers placed on a level contour pond sheet flow runoff, allowing sediment to settle out.

Suitable Applications

Sandbag barriers may be suitable:

- As a linear sediment control measure:
 - Below the toe of slopes and erodible slopes.
 - As sediment traps at culvert/pipe outlets.
 - Below other small cleared areas.
 - Along the perimeter of a site.
 - Down slope of exposed soil areas.
 - Around temporary stockpiles and spoil areas.
 - Parallel to a roadway to keep sediment off paved areas.
 - Along streams and channels.
- As linear erosion control measure:
 - Along the face and at grade breaks of exposed and erodible slopes to shorten slope length and spread runoff as sheet flow.

Targeted Constituents

Sediment	<input checked="" type="checkbox"/>
Nutrients	
Trash	
Metals	
Bacteria	
Oil and Grease	
Organics	

Potential Alternatives

- SE-1 Silt Fence
- SE-5 Fiber Rolls
- SE-6 Gravel Bag Berm
- SE-14 Biofilter Bags

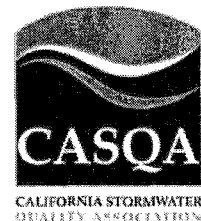

Sandbag Barrier

SE-8

- At the top of slopes to divert runoff away from disturbed slopes.
- As check dams across mildly sloped construction roads.

Limitations

- It is necessary to limit the drainage area upstream of the barrier to 5 acres.
- Sandbags are not intended to be used as filtration devices.
- Easily damaged by construction equipment.
- Degraded sandbags may rupture when removed, spilling sand.
- Sand is easily transported by runoff if bag is damaged or ruptured.
- Installation can be labor intensive.
- Durability of sandbags is somewhat limited and bags may need to be replaced when installation is required for longer than 6 months. When used to detain concentrated flows, maintenance requirements increase.
- Burlap should not be used for sandbags.

Implementation

General

A sandbag barrier consists of a row of sand-filled bags placed on a level contour. When appropriately placed, a sandbag barrier intercepts and slows sheet flow runoff, causing temporary ponding. The temporary ponding allows sediment to settle. Sand-filled bags have limited porosity, which is further limited as the fine sand tends to quickly plug with sediment, limiting or completely blocking the rate of flow through the barrier. If a porous barrier is desired, consider SE-1, Silt Fence, SE-5, Fiber Rolls, SE-6, Gravel Bag Berms or SE-14, Biofilter Bags. Sandbag barriers also interrupt the slope length and thereby reduce erosion by reducing the tendency of sheet flows to concentrate into rivulets which erode rills, and ultimately gullies, into disturbed, sloped soils. Sandbag barriers are similar to gravel bag berms, but less porous. Generally, sandbag barriers should be used in conjunction with temporary soil stabilization controls up slope to provide effective erosion and sediment control.

Design and Layout

- Locate sandbag barriers on a level contour.
- When used for slope interruption, the following slope/sheet flow length combinations apply:
 - Slope inclination of 4:1 (H:V) or flatter: Sandbags should be placed at a maximum interval of 20 ft, with the first row near the slope toe.
 - Slope inclination between 4:1 and 2:1 (H:V): Sandbags should be placed at a maximum interval of 15 ft. (a closer spacing is more effective), with the first row near the slope toe.
 - Slope inclination 2:1 (H:V) or greater: Sandbags should be placed at a maximum interval of 10 ft. (a closer spacing is more effective), with the first row near the slope toe.

Sandbag Barrier

SE-8

- Turn the ends of the sandbag barrier up slope to prevent runoff from going around the barrier.
- Allow sufficient space up slope from the barrier to allow ponding, and to provide room for sediment storage.
- For installation near the toe of the slope, sand bag barriers should be set back from the slope toe to facilitate cleaning. Where specific site conditions do not allow for a set-back, the sand bag barrier may be constructed on the toe of the slope. To prevent flows behind the barrier, bags can be placed perpendicular to a berm to serve as cross barriers.
- Drainage area should not exceed 5 acres.
- Stack sandbags at least three bags high.
- Butt ends of bags tightly.
- Overlap butt joints of row beneath with each successive row.
- Use a pyramid approach when stacking bags.
- In non-traffic areas
 - Height = 18 in. maximum
 - Top width = 24 in. minimum for three or more layer construction
 - Side slope = 2:1 (H:V) or flatter
- In construction traffic areas
 - Height = 12 in. maximum
 - Top width = 24 in. minimum for three or more layer construction.
 - Side slopes = 2:1 (H:V) or flatter.
- See typical sandbag barrier installation details at the end of this fact sheet.

Materials

- **Sandbag Material:** Sandbag should be woven polypropylene, polyethylene or polyamide fabric, minimum unit weight of 4 ounces/yd², Mullen burst strength exceeding 300 lb/in² in conformance with the requirements in ASTM designation D3786, and ultraviolet stability exceeding 70% in conformance with the requirements in ASTM designation D4355. Use of burlap is not an acceptable substitute, as sand can more easily mobilize out of burlap.
- **Sandbag Size:** Each sand-filled bag should have a length of 18 in., width of 12 in., thickness of 3 in., and mass of approximately 33 lbs. Bag dimensions are nominal, and may vary based on locally available materials.

Sandbag Barrier

SE-8

- **Fill Material:** All sandbag fill material should be non-cohesive, Class 3 (Caltrans Standard Specification, Section 25) permeable material free from clay and deleterious material, such as recycled concrete or asphalt..

Costs

Empty sandbags cost \$0.25 - \$0.75. Average cost of fill material is \$8 per yd³. Additional labor is required to fill the bags. Pre-filled sandbags are more expensive at \$1.50 - \$2.00 per bag. These costs are based upon vendor research.

Inspection and Maintenance

- BMPs must be inspected in accordance with General Permit requirements for the associated project type and risk level. It is recommended that at a minimum, BMPs be inspected weekly, prior to forecasted rain events, daily during extended rain events, and after the conclusion of rain events.
- Sandbags exposed to sunlight will need to be replaced every two to three months due to degradation of the bags.
- Reshape or replace sandbags as needed.
- Repair washouts or other damage as needed.
- Sediment that accumulates behind the BMP should be periodically removed in order to maintain BMP effectiveness. Sediment should be removed when the sediment accumulation reaches one-third of the barrier height.
- Remove sandbags when no longer needed and recycle sand fill whenever possible and properly dispose of bag material. Remove sediment accumulation, and clean, re-grade, and stabilize the area.

References

Standard Specifications for Construction of Local Streets and Roads, California Department of Transportation (Caltrans), July 2002.

Stormwater Quality Handbooks - Construction Site Best Management Practices (BMPs) Manual, State of California Department of Transportation (Caltrans), March 2003.

Erosion and Sediment Control Manual, Oregon Department of Environmental Quality, February 2005.

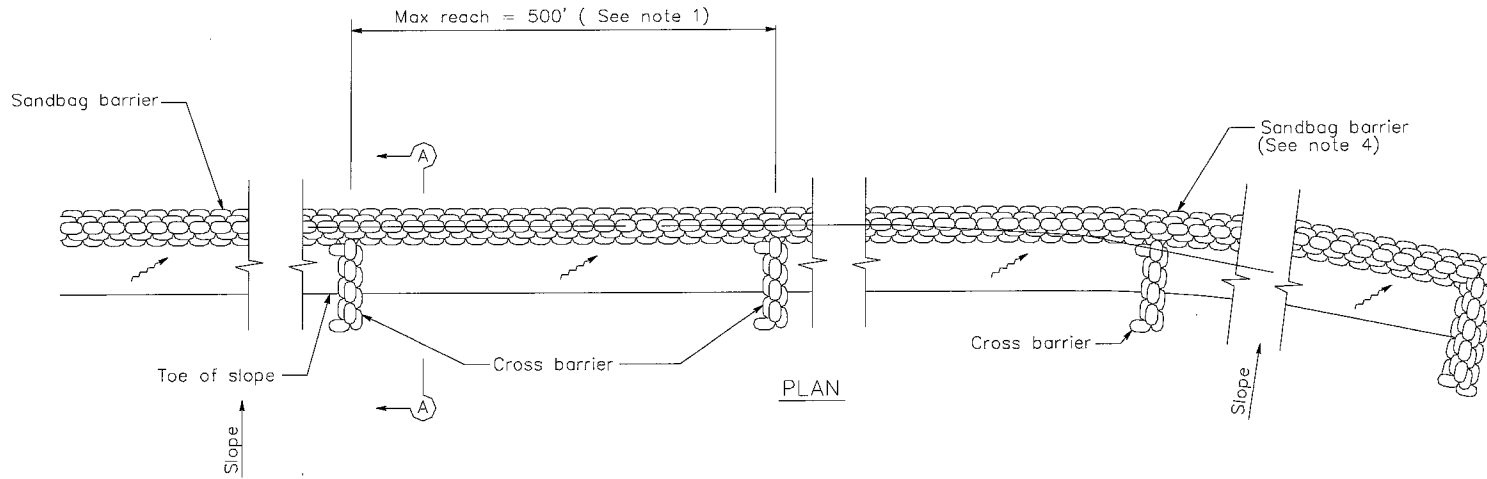

SANDBAG BARRIER

NOTES

1. Construct the length of each reach so that the change in base elevation along the reach does not exceed $1/2$ the height of the linear barrier. In no case shall the reach length exceed 500'.
2. Place sandbags tightly.
3. Dimension may vary to fit field condition.
4. Sandbag barrier shall be a minimum of 3 bags high.
5. The end of the barrier shall be turned up slope.
6. Cross barriers shall be a min of $1/2$ and a max of $2/3$ the height of the linear barrier.
7. Sandbag rows and layers shall be staggered to eliminate gaps.

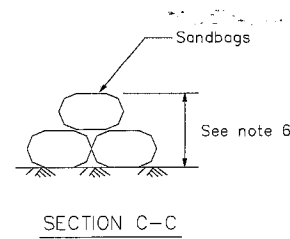
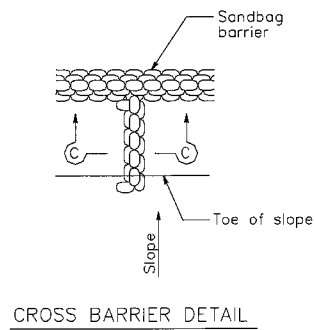
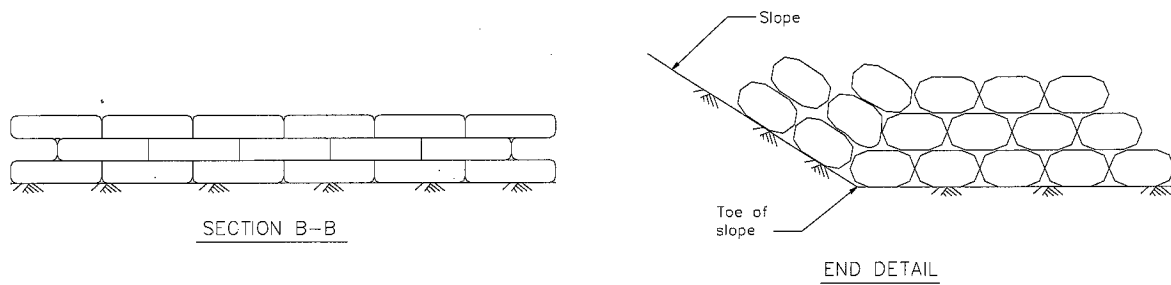
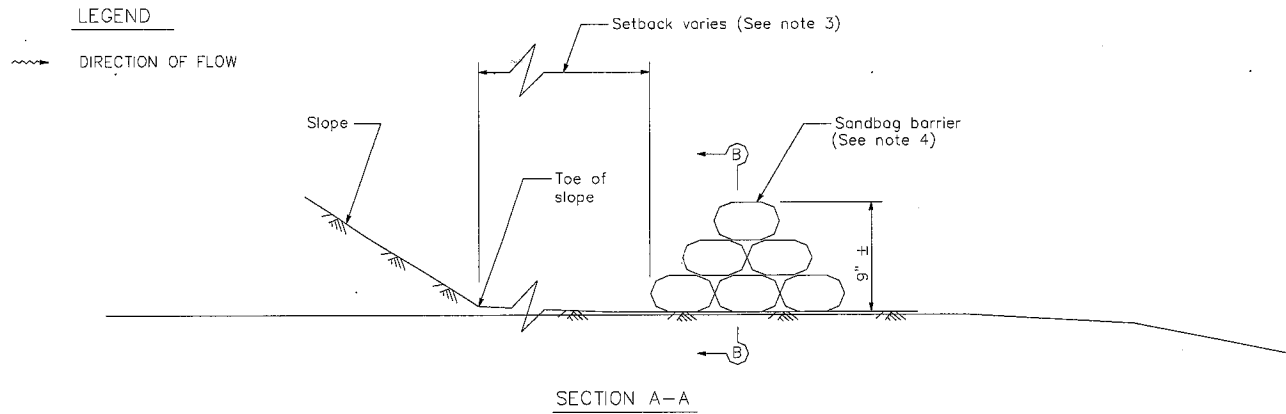

Fiber Rolls

SE-5

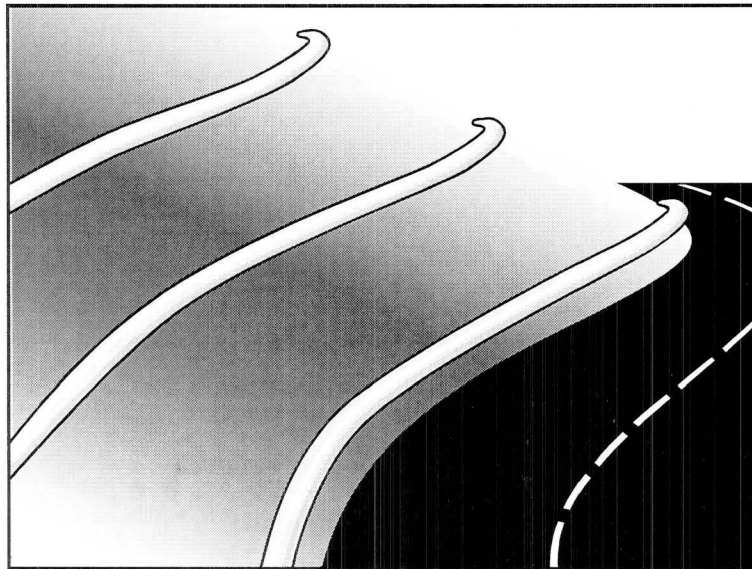

Description and Purpose

A fiber roll consists of straw, coir, or other biodegradable materials bound into a tight tubular roll wrapped by netting, which can be photodegradable or natural. Additionally, gravel core fiber rolls are available, which contain an imbedded ballast material such as gravel or sand for additional weight when staking the rolls are not feasible (such as use as inlet protection). When fiber rolls are placed at the toe and on the face of slopes along the contours, they intercept runoff, reduce its flow velocity, release the runoff as sheet flow, and provide removal of sediment from the runoff (through sedimentation). By interrupting the length of a slope, fiber rolls can also reduce sheet and rill erosion until vegetation is established.

Suitable Applications

Fiber rolls may be suitable:

- Along the toe, top, face, and at grade breaks of exposed and erodible slopes to shorten slope length and spread runoff as sheet flow.
- At the end of a downward slope where it transitions to a steeper slope.
- Along the perimeter of a project.
- As check dams in unlined ditches with minimal grade.
- Down-slope of exposed soil areas.
- At operational storm drains as a form of inlet protection.

Categories

EC	Erosion Control	<input checked="" type="checkbox"/>
SE	Sediment Control	<input checked="" type="checkbox"/>
TC	Tracking Control	
WE	Wind Erosion Control	
NS	Non-Stormwater Management Control	
WM	Waste Management and Materials Pollution Control	

Legend:

- Primary Category
- Secondary Category

Targeted Constituents

Sediment	<input checked="" type="checkbox"/>
Nutrients	
Trash	
Metals	
Bacteria	
Oil and Grease	
Organics	

Potential Alternatives

- SE-1 Silt Fence
- SE-6 Gravel Bag Berm
- SE-8 Sandbag Barrier
- SE-14 Biofilter Bags



Fiber Rolls

SE-5

- Around temporary stockpiles.

Limitations

- Fiber rolls are not effective unless trenched in and staked.
- Not intended for use in high flow situations.
- Difficult to move once saturated.
- If not properly staked and trenched in, fiber rolls could be transported by high flows.
- Fiber rolls have a very limited sediment capture zone.
- Fiber rolls should not be used on slopes subject to creep, slumping, or landslide.
- Rolls typically function for 12-24 months depending upon local conditions.

Implementation

Fiber Roll Materials

- Fiber rolls should be prefabricated.
- Fiber rolls may come manufactured containing polyacrylamide (PAM), a flocculating agent within the roll. Fiber rolls impregnated with PAM provide additional sediment removal capabilities and should be used in areas with fine, clayey or silty soils to provide additional sediment removal capabilities. Monitoring may be required for these installations.
- Fiber rolls are made from weed free rice straw, flax, or a similar agricultural material bound into a tight tubular roll by netting.
- Typical fiber rolls vary in diameter from 9 in. to 20 in. Larger diameter rolls are available as well.

Installation

- Locate fiber rolls on level contours spaced as follows:
 - Slope inclination of 4:1 (H:V) or flatter: Fiber rolls should be placed at a maximum interval of 20 ft.
 - Slope inclination between 4:1 and 2:1 (H:V): Fiber Rolls should be placed at a maximum interval of 15 ft. (a closer spacing is more effective).
 - Slope inclination 2:1 (H:V) or greater: Fiber Rolls should be placed at a maximum interval of 10 ft. (a closer spacing is more effective).
- Prepare the slope before beginning installation.
- Dig small trenches across the slope on the contour. The trench depth should be $\frac{1}{4}$ to $\frac{1}{3}$ of the thickness of the roll, and the width should equal the roll diameter, in order to provide area to backfill the trench.

Fiber Rolls

SE-5

- It is critical that rolls are installed perpendicular to water movement, and parallel to the slope contour.
- Start building trenches and installing rolls from the bottom of the slope and work up.
- It is recommended that pilot holes be driven through the fiber roll. Use a straight bar to drive holes through the roll and into the soil for the wooden stakes.
- Turn the ends of the fiber roll up slope to prevent runoff from going around the roll.
- Stake fiber rolls into the trench.
 - Drive stakes at the end of each fiber roll and spaced 4 ft maximum on center.
 - Use wood stakes with a nominal classification of 0.75 by 0.75 in. and minimum length of 24 in.
- If more than one fiber roll is placed in a row, the rolls should be overlapped, not abutted.
- See typical fiber roll installation details at the end of this fact sheet.

Removal

- Fiber rolls can be left in place or removed depending on the type of fiber roll and application (temporary vs. permanent installation). Typically, fiber rolls encased with plastic netting are used for a temporary application because the netting does not biodegrade. Fiber rolls used in a permanent application are typically encased with a biodegradable material and are left in place. Removal of a fiber roll used in a permanent application can result in greater disturbance.
- Temporary installations should only be removed when up gradient areas are stabilized per General Permit requirements, and/or pollutant sources no longer present a hazard. But, they should also be removed before vegetation becomes too mature so that the removal process does not disturb more soil and vegetation than is necessary.

Costs

Material costs for regular fiber rolls range from \$20 - \$30 per 25 ft roll.

Material costs for PAM impregnated fiber rolls range between 7.00-\$9.00 per linear foot, based upon vendor research.

Inspection and Maintenance

- BMPs must be inspected in accordance with General Permit requirements for the associated project type and risk level. It is recommended that at a minimum, BMPs be inspected weekly, prior to forecasted rain events, daily during extended rain events, and after the conclusion of rain events.
- Repair or replace split, torn, unraveling, or slumping fiber rolls.
- If the fiber roll is used as a sediment capture device, or as an erosion control device to maintain sheet flows, sediment that accumulates in the BMP should be periodically removed

Fiber Rolls

SE-5

in order to maintain BMP effectiveness. Sediment should be removed when sediment accumulation reaches one-third the designated sediment storage depth.

- If fiber rolls are used for erosion control, such as in a check dam, sediment removal should not be required as long as the system continues to control the grade. Sediment control BMPs will likely be required in conjunction with this type of application.
- Repair any rills or gullies promptly.

References

Stormwater Quality Handbooks - Construction Site Best Management Practices (BMPs) Manual, State of California Department of Transportation (Caltrans), March 2003.

Erosion and Sediment Control Manual, Oregon Department of Environmental Quality, February 2005.

Fiber Rolls

SE-5

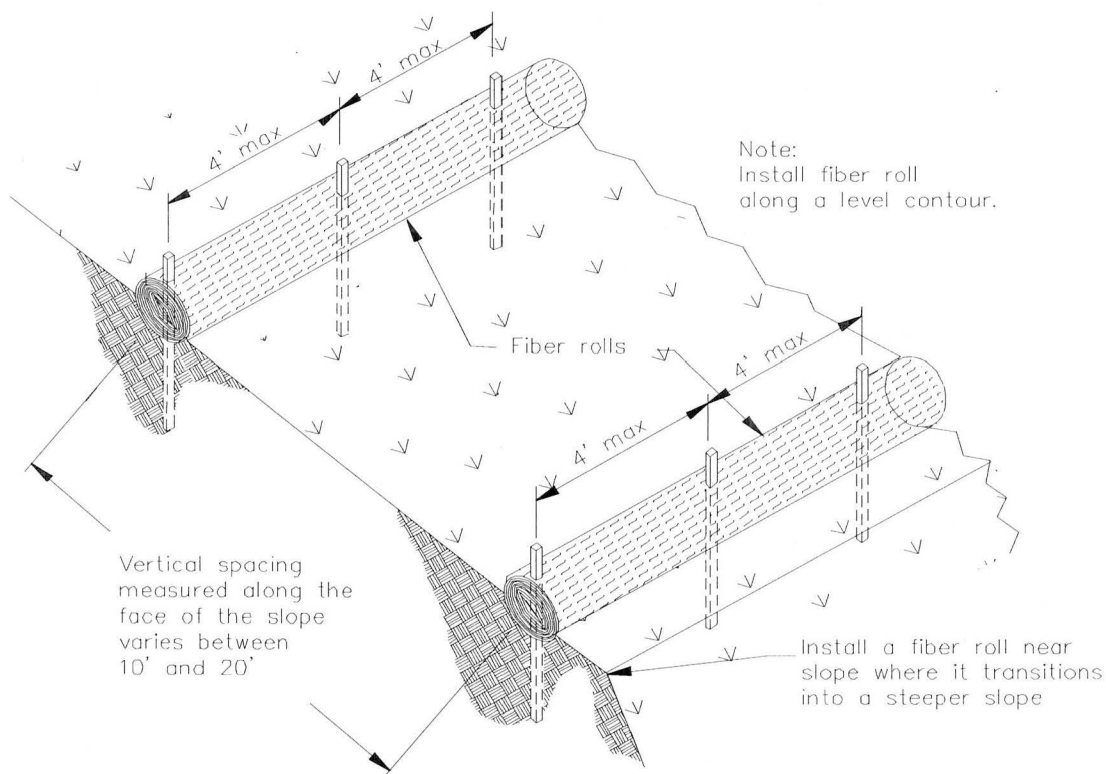

TYPICAL FIBER ROLL INSTALLATION

N.T.S.

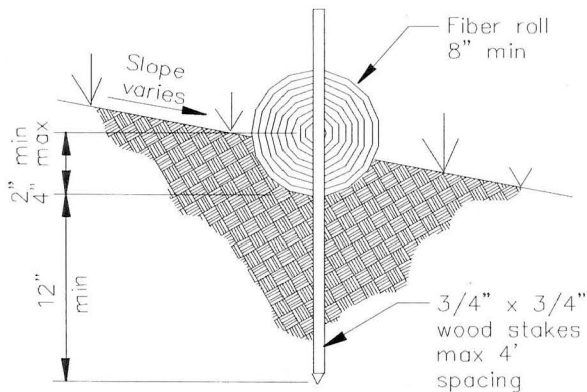

ENTRENCHMENT DETAIL

N.T.S.

Violation No. 6

Failure to Implement Erosion Control BMPs in
Active Areas
(22 days)

Fiber Rolls

SE-5

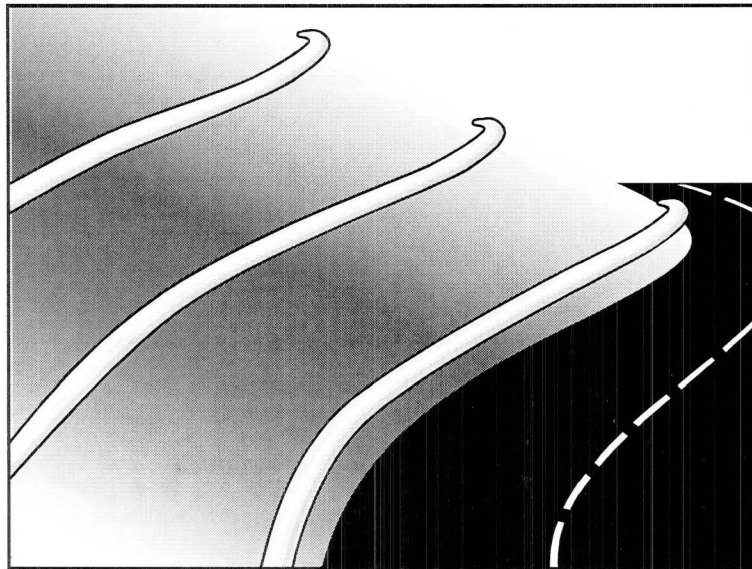

Description and Purpose

A fiber roll consists of straw, coir, or other biodegradable materials bound into a tight tubular roll wrapped by netting, which can be photodegradable or natural. Additionally, gravel core fiber rolls are available, which contain an imbedded ballast material such as gravel or sand for additional weight when staking the rolls are not feasible (such as use as inlet protection). When fiber rolls are placed at the toe and on the face of slopes along the contours, they intercept runoff, reduce its flow velocity, release the runoff as sheet flow, and provide removal of sediment from the runoff (through sedimentation). By interrupting the length of a slope, fiber rolls can also reduce sheet and rill erosion until vegetation is established.

Suitable Applications

Fiber rolls may be suitable:

- Along the toe, top, face, and at grade breaks of exposed and erodible slopes to shorten slope length and spread runoff as sheet flow.
- At the end of a downward slope where it transitions to a steeper slope.
- Along the perimeter of a project.
- As check dams in unlined ditches with minimal grade.
- Down-slope of exposed soil areas.
- At operational storm drains as a form of inlet protection.

Categories

EC	Erosion Control	<input checked="" type="checkbox"/>
SE	Sediment Control	<input checked="" type="checkbox"/>
TC	Tracking Control	
WE	Wind Erosion Control	
NS	Non-Stormwater Management Control	
WM	Waste Management and Materials Pollution Control	

Legend:

- Primary Category
- Secondary Category

Targeted Constituents

Sediment	<input checked="" type="checkbox"/>
Nutrients	
Trash	
Metals	
Bacteria	
Oil and Grease	
Organics	

Potential Alternatives

- SE-1 Silt Fence
- SE-6 Gravel Bag Berm
- SE-8 Sandbag Barrier
- SE-14 Biofilter Bags



Fiber Rolls

SE-5

- Around temporary stockpiles.

Limitations

- Fiber rolls are not effective unless trenched in and staked.
- Not intended for use in high flow situations.
- Difficult to move once saturated.
- If not properly staked and trenched in, fiber rolls could be transported by high flows.
- Fiber rolls have a very limited sediment capture zone.
- Fiber rolls should not be used on slopes subject to creep, slumping, or landslide.
- Rolls typically function for 12-24 months depending upon local conditions.

Implementation

Fiber Roll Materials

- Fiber rolls should be prefabricated.
- Fiber rolls may come manufactured containing polyacrylamide (PAM), a flocculating agent within the roll. Fiber rolls impregnated with PAM provide additional sediment removal capabilities and should be used in areas with fine, clayey or silty soils to provide additional sediment removal capabilities. Monitoring may be required for these installations.
- Fiber rolls are made from weed free rice straw, flax, or a similar agricultural material bound into a tight tubular roll by netting.
- Typical fiber rolls vary in diameter from 9 in. to 20 in. Larger diameter rolls are available as well.

Installation

- Locate fiber rolls on level contours spaced as follows:
 - Slope inclination of 4:1 (H:V) or flatter: Fiber rolls should be placed at a maximum interval of 20 ft.
 - Slope inclination between 4:1 and 2:1 (H:V): Fiber Rolls should be placed at a maximum interval of 15 ft. (a closer spacing is more effective).
 - Slope inclination 2:1 (H:V) or greater: Fiber Rolls should be placed at a maximum interval of 10 ft. (a closer spacing is more effective).
- Prepare the slope before beginning installation.
- Dig small trenches across the slope on the contour. The trench depth should be 1/4 to 1/3 of the thickness of the roll, and the width should equal the roll diameter, in order to provide area to backfill the trench.

Fiber Rolls

SE-5

- It is critical that rolls are installed perpendicular to water movement, and parallel to the slope contour.
- Start building trenches and installing rolls from the bottom of the slope and work up.
- It is recommended that pilot holes be driven through the fiber roll. Use a straight bar to drive holes through the roll and into the soil for the wooden stakes.
- Turn the ends of the fiber roll up slope to prevent runoff from going around the roll.
- Stake fiber rolls into the trench.
 - Drive stakes at the end of each fiber roll and spaced 4 ft maximum on center.
 - Use wood stakes with a nominal classification of 0.75 by 0.75 in. and minimum length of 24 in.
- If more than one fiber roll is placed in a row, the rolls should be overlapped, not abutted.
- See typical fiber roll installation details at the end of this fact sheet.

Removal

- Fiber rolls can be left in place or removed depending on the type of fiber roll and application (temporary vs. permanent installation). Typically, fiber rolls encased with plastic netting are used for a temporary application because the netting does not biodegrade. Fiber rolls used in a permanent application are typically encased with a biodegradable material and are left in place. Removal of a fiber roll used in a permanent application can result in greater disturbance.
- Temporary installations should only be removed when up gradient areas are stabilized per General Permit requirements, and/or pollutant sources no longer present a hazard. But, they should also be removed before vegetation becomes too mature so that the removal process does not disturb more soil and vegetation than is necessary.

Costs

Material costs for regular fiber rolls range from \$20 - \$30 per 25 ft roll.

Material costs for PAM impregnated fiber rolls range between 7.00-\$9.00 per linear foot, based upon vendor research.

Inspection and Maintenance

- BMPs must be inspected in accordance with General Permit requirements for the associated project type and risk level. It is recommended that at a minimum, BMPs be inspected weekly, prior to forecasted rain events, daily during extended rain events, and after the conclusion of rain events.
- Repair or replace split, torn, unraveling, or slumping fiber rolls.
- If the fiber roll is used as a sediment capture device, or as an erosion control device to maintain sheet flows, sediment that accumulates in the BMP should be periodically removed

Fiber Rolls

SE-5

in order to maintain BMP effectiveness. Sediment should be removed when sediment accumulation reaches one-third the designated sediment storage depth.

- If fiber rolls are used for erosion control, such as in a check dam, sediment removal should not be required as long as the system continues to control the grade. Sediment control BMPs will likely be required in conjunction with this type of application.
- Repair any rills or gullies promptly.

References

Stormwater Quality Handbooks - Construction Site Best Management Practices (BMPs) Manual, State of California Department of Transportation (Caltrans), March 2003.

Erosion and Sediment Control Manual, Oregon Department of Environmental Quality, February 2005.

Fiber Rolls

SE-5

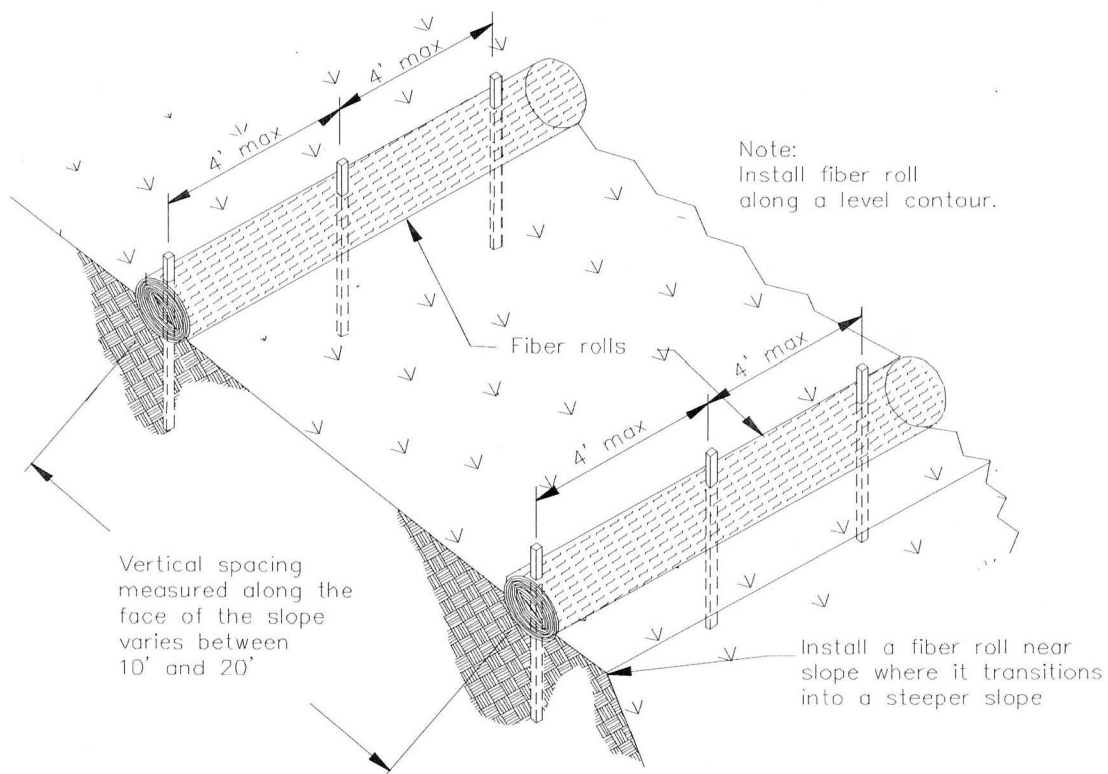

TYPICAL FIBER ROLL INSTALLATION

N.T.S.

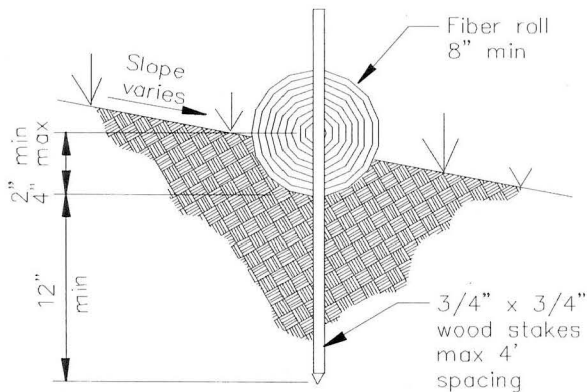

ENTRENCHMENT DETAIL

N.T.S.

Hydraulic Mulch

EC-3

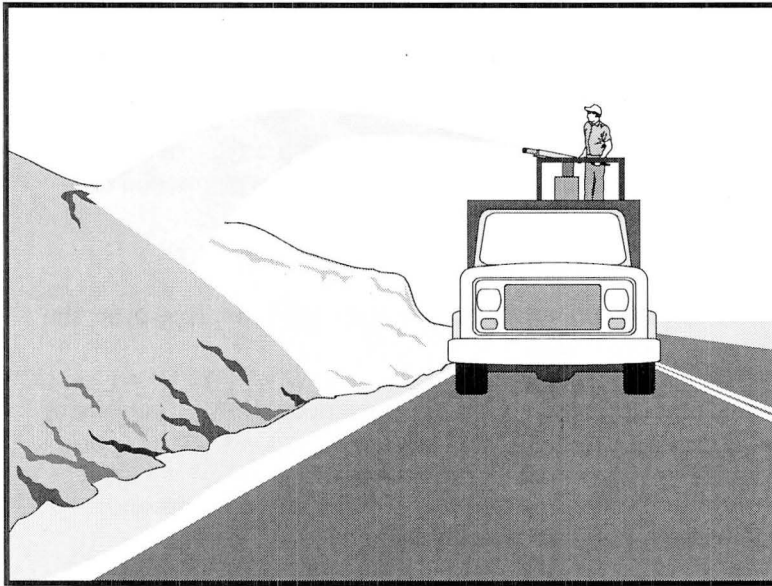

Categories

EC	Erosion Control	<input checked="" type="checkbox"/>
SE	Sediment Control	
TC	Tracking Control	
WE	Wind Erosion Control	<input checked="" type="checkbox"/>
NS	Non-Stormwater Management Control	
WM	Waste Management and Materials Pollution Control	

Legend:

- Primary Category
- Secondary Category

Targeted Constituents

Sediment	<input checked="" type="checkbox"/>
Nutrients	
Trash	
Metals	
Bacteria	
Oil and Grease	
Organics	

Potential Alternatives

- EC-4 Hydroseeding
- EC-5 Soil Binders
- EC-6 Straw Mulch
- EC-7 Geotextiles and Mats
- EC-8 Wood Mulching
- EC-14 Compost Blanket
- EC-16 Non-Vegetative Stabilization

Description and Purpose

Hydraulic Mulch consists of various types of fibrous materials mixed with water and sprayed onto the soil surface in slurry form to provide a layer of temporary protection from wind and water erosion.

Suitable Applications

Hydraulic mulch as a temporary, stand alone, erosion control BMP is suitable for disturbed areas that require temporary protection from wind and water erosion until permanent soil stabilization activities commence. Examples include:

- Rough-graded areas that will remain inactive for longer than permit-required thresholds (e.g., 14 days) or otherwise require stabilization to minimize erosion or prevent sediment discharges.
- Soil stockpiles.
- Slopes with exposed soil between existing vegetation such as trees or shrubs.
- Slopes planted with live, container-grown vegetation or plugs.
- Slopes burned by wildfire.

Hydraulic mulch can also be applied to augment other erosion control BMPs such as:



Hydraulic Mulch

EC-3

- In conjunction with straw mulch (see EC-6 Straw Mulch) where the rate of hydraulic mulch is reduced to 100-500 lbs per acre and the slurry is applied over the straw as a tackifying agent to hold the straw in place.
- Supplemental application of soil amendments, such as fertilizer, lime, gypsum, soil bio-stimulants or compost.

Limitations

In general, hydraulic mulch is not limited by slope length, gradient or soil type. However, the following limitations typically apply:

- Most hydraulic mulch applications, particularly bonded fiber matrices (BFMs), require at least 24 hours to dry before rainfall occurs.
- Temporary applications (i.e., without a vegetative component) may require a second application in order to remain effective for an entire rainy season.
- Treatment areas must be accessible to hydraulic mulching equipment.
- Availability of water sources in remote areas for mixing and application.
- As a stand-alone temporary BMP, hydraulic mulches may need to be re-applied to maintain their erosion control effectiveness, typically after 6-12 months depending on the type of mulch used.
- Availability of hydraulic mulching equipment may be limited just prior to the rainy season and prior to storms due to high demand.
- Cellulose fiber mulches alone may not perform well on steep slopes or in coarse soils.

Implementation

- Where feasible, it is preferable to prepare soil surfaces prior to application by roughening embankments and fill areas with a crimping or punching type roller or by track walking.
- The majority of hydraulic mulch applications do not necessarily require surface/soil preparation (See EC-15 Soil Preparation) although in almost every case where re-vegetation is included as part of the practice, soil preparation can be beneficial. One of the advantages of hydraulic mulch over other erosion control methods is that it can be applied in areas where soil preparation is precluded by site conditions, such as steep slopes, rocky soils, or inaccessibility.
- Avoid mulch over spray onto roads, sidewalks, drainage channels, existing vegetation, etc.
- Hydraulic mulching is generally performed utilizing specialized machines that have a large water-holding/mixing tank and some form of mechanical agitation or other recirculation method to keep water, mulch and soil amendments in suspension. The mixed hydraulic slurry can be applied from a tower sprayer on top of the machine or by extending a hose to areas remote from the machine.

Hydraulic Mulch

EC-3

- Where possible apply hydraulic mulch from multiple directions to adequately cover the soil. Application from a single direction can result in shadowing, uneven coverage and failure of the BMP.
- Hydraulic mulch can also include a vegetative component, such as seed, rhizomes, or stolons (see EC-4 Hydraulic Seed).
- Typical hydraulic mulch application rates range from 2,000 pounds per acre for standard mulches (SMs) to 3,500 pounds per acre for BFMs. However, the required amount of hydraulic mulch to provide adequate coverage of exposed topsoil may appear to exceed the standard rates when the roughness of the soil surface is changed due to soil preparation methods (see EC-15 Soil Preparation) or by slope gradient.
- Other factors such as existing soil moisture and soil texture can have a profound effect on the amount of hydraulic mulch required (i.e. application rate) applied to achieve an erosion-resistant covering.
- Avoid use of mulch without a tackifier component, especially on slopes.
- Mulches used in the hydraulic mulch slurry can include:
 - Cellulose fiber
 - Thermally-processed wood fibers
 - Cotton
 - Synthetics
 - Compost (see EC-14, Compost Blanket)
- Additional guidance on the comparison and selection of temporary slope stabilization methods is provided in Appendix F of the Handbook.

Categories of Hydraulic Mulches

Standard Hydraulic Mulch (SM)

Standard hydraulic mulches are generally applied at a rate of 2,000 pounds per acre and are manufactured containing around 5% tackifier (i.e. soil binder), usually a plant-derived guar or psyllium type. Most standard mulches are green in color derived from food-color based dyes.

Hydraulic Matrices (HM) and Stabilized Fiber Matrices (SFM)

Hydraulic matrices and stabilized fiber matrices are slurries which contain increased levels of tackifiers/soil binders; usually 10% or more by weight. HMs and SFMs have improved performance compared to a standard hydraulic mulch (SM) because of the additional percentage of tackifier and because of their higher application rates, typically 2,500 – 4,000 pounds per acre. Hydraulic matrices can include a mixture of fibers, for example, a 50/50 blend of paper and wood fiber. In the case of an SFM, the tackifier/soil binder is specified as a polyacrylamide (PAM).

Hydraulic Mulch

EC-3

Bonded Fiber Matrix (BFM)

Bonded fiber matrices (BFMs) are hydraulically-applied systems of fibers, adhesives (typically guar based) and chemical cross-links. Upon drying, the slurry forms an erosion-resistant blanket that prevents soil erosion and promotes vegetation establishment. The cross-linked adhesive in the BFM should be biodegradable and should not dissolve or disperse upon re-wetting. BFMs are typically applied at rates from 3,000 to 4,000 lbs/acre based on the manufacturer's recommendation. BFMs should not be applied immediately before, during or immediately after rainfall or if the soil is saturated. Depending on the product, BFMs typically require 12 to 24 hours to dry and become effective.

Mechanically-Bonded Fiber Matrices (MBFM)

Mechanically-bonded fiber matrices (MBFMs) are hydraulically applied systems similar to BFM that use crimped synthetic fibers and PAM and are typically applied to a slope at a higher application rate than a standard BFM.

Hydraulic Compost Matrix (HCM)

Hydraulic compost matrix (HCM) is a field-derived practice whereby finely graded or sifted compost is introduced into the hydraulic mulch slurry. A guar-type tackifier can be added for steeper slope applications as well as any specified seed mixtures. A HCM can help to accelerate seed germination and growth. HCMs are particularly useful as an in-fill for three-dimensional re-vegetation geocomposites, such as turf reinforcement mats (TRM) (see EC-7 Geotextiles and Mats).

Costs

Average installed costs for hydraulic mulch categories are is provided in Table 1, below.

Table 1
HYDRAULIC MULCH BMPs
INSTALLED COSTS

BMP	Installed Cost/Acre
Standard Hydraulic Mulching (SM)	\$1,700 - \$3,600 per acre
Hydraulic Matrices (HM) and Stabilized Fiber Matrices	
Guar-based	\$2,000 - \$4,000 per acre
PAM-based	\$2,500 - \$5,610 per acre
Bonded Fiber Matrix (BFM)	\$3,900 - \$6,900 per acre
Mechanically Bonded Fiber Matrix (MBFM)	\$4,500 - \$6,000 per acre
Hydraulic Compost Matrix (HCM)	\$3,000 - \$3,500 per acre

Source: Caltrans Soil Stabilization BMP Research for Erosion and Sediment Controls, July 2007

Inspection and Maintenance

- Maintain an unbroken, temporary mulched ground cover throughout the period of construction when the soils are not being reworked.
- BMPs must be inspected in accordance with General Permit requirements for the associated project type and risk level. It is recommended that at a minimum, BMPs be inspected

Hydraulic Mulch

EC-3

weekly, prior to forecasted rain events, daily during extended rain events, and after the conclusion of rain events.

- Areas where erosion is evident should be repaired and BMPs re-applied as soon as possible. Care should be exercised to minimize the damage to protected areas while making repairs, as any area damaged will require re-application of BMPs.
- Compare the number of bags or weight of applied mulch to the area treated to determine actual application rates and compliance with specifications.

References

Soil Stabilization BMP Research for Erosion and Sediment Controls: Cost Survey Technical Memorandum, State of California Department of Transportation (Caltrans), July 2007.

Controlling Erosion of Construction Sites, Agriculture Information #347, U.S. Department of Agriculture (USDA), Natural Resources Conservation Service (NRCS) (formerly Soil Conservation Service – SCS).

Guides for Erosion and Sediment Control in California, USDA Soils Conservation Service, January 1991.

Manual of Standards of Erosion and Sediment Control Measures, Association of Bay Area Governments, May 1995.

Sedimentation and Erosion Control, An Inventory of Current Practices Draft, US EPA, April 1990.

Soil Erosion by Water, Agriculture Information Bulletin #513, U.S. Department of Agriculture, Soil Conservation Service.

Stormwater Quality Handbooks Construction Site Best Management Practices (BMPs) Manual, State of California Department of Transportation (Caltrans), March 2003.

Guidance Document: Soil Stabilization for Temporary Slopes, State of California Department of Transportation (Caltrans), November 1999

Stormwater Management of the Puget Sound Basin, Technical Manual, Publication #91-75, Washington State Department of Ecology, February 1992.

Water Quality Management Plan for the Lake Tahoe Region, Volume II, Handbook of Management Practices, Tahoe Regional Planning Agency, November 1988.

Violation No. 7

Failure to Apply Linear Sediment Controls
(9 days)

Fiber Rolls

SE-5

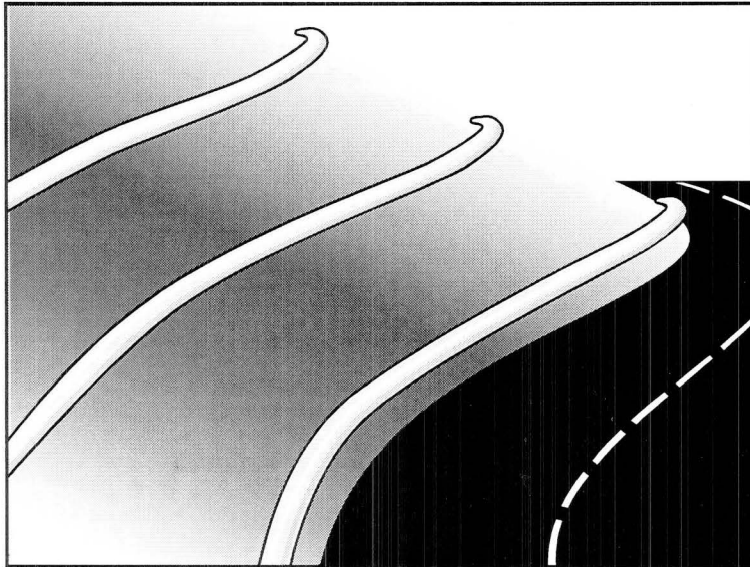

Description and Purpose

A fiber roll consists of straw, coir, or other biodegradable materials bound into a tight tubular roll wrapped by netting, which can be photodegradable or natural. Additionally, gravel core fiber rolls are available, which contain an imbedded ballast material such as gravel or sand for additional weight when staking the rolls are not feasible (such as use as inlet protection). When fiber rolls are placed at the toe and on the face of slopes along the contours, they intercept runoff, reduce its flow velocity, release the runoff as sheet flow, and provide removal of sediment from the runoff (through sedimentation). By interrupting the length of a slope, fiber rolls can also reduce sheet and rill erosion until vegetation is established.

Suitable Applications

Fiber rolls may be suitable:

- Along the toe, top, face, and at grade breaks of exposed and erodible slopes to shorten slope length and spread runoff as sheet flow.
- At the end of a downward slope where it transitions to a steeper slope.
- Along the perimeter of a project.
- As check dams in unlined ditches with minimal grade.
- Down-slope of exposed soil areas.
- At operational storm drains as a form of inlet protection.

Categories

EC	Erosion Control	<input checked="" type="checkbox"/>
SE	Sediment Control	<input checked="" type="checkbox"/>
TC	Tracking Control	
WE	Wind Erosion Control	
NS	Non-Stormwater Management Control	
WM	Waste Management and Materials Pollution Control	

Legend:

- Primary Category
- Secondary Category

Targeted Constituents

Sediment	<input checked="" type="checkbox"/>
Nutrients	
Trash	
Metals	
Bacteria	
Oil and Grease	
Organics	

Potential Alternatives

- SE-1 Silt Fence
- SE-6 Gravel Bag Berm
- SE-8 Sandbag Barrier
- SE-14 Biofilter Bags



Fiber Rolls

SE-5

- Around temporary stockpiles.

Limitations

- Fiber rolls are not effective unless trenched in and staked.
- Not intended for use in high flow situations.
- Difficult to move once saturated.
- If not properly staked and trenched in, fiber rolls could be transported by high flows.
- Fiber rolls have a very limited sediment capture zone.
- Fiber rolls should not be used on slopes subject to creep, slumping, or landslide.
- Rolls typically function for 12-24 months depending upon local conditions.

Implementation

Fiber Roll Materials

- Fiber rolls should be prefabricated.
- Fiber rolls may come manufactured containing polyacrylamide (PAM), a flocculating agent within the roll. Fiber rolls impregnated with PAM provide additional sediment removal capabilities and should be used in areas with fine, clayey or silty soils to provide additional sediment removal capabilities. Monitoring may be required for these installations.
- Fiber rolls are made from weed free rice straw, flax, or a similar agricultural material bound into a tight tubular roll by netting.
- Typical fiber rolls vary in diameter from 9 in. to 20 in. Larger diameter rolls are available as well.

Installation

- Locate fiber rolls on level contours spaced as follows:
 - Slope inclination of 4:1 (H:V) or flatter: Fiber rolls should be placed at a maximum interval of 20 ft.
 - Slope inclination between 4:1 and 2:1 (H:V): Fiber Rolls should be placed at a maximum interval of 15 ft. (a closer spacing is more effective).
 - Slope inclination 2:1 (H:V) or greater: Fiber Rolls should be placed at a maximum interval of 10 ft. (a closer spacing is more effective).
- Prepare the slope before beginning installation.
- Dig small trenches across the slope on the contour. The trench depth should be 1/4 to 1/3 of the thickness of the roll, and the width should equal the roll diameter, in order to provide area to backfill the trench.

Fiber Rolls

SE-5

- It is critical that rolls are installed perpendicular to water movement, and parallel to the slope contour.
- Start building trenches and installing rolls from the bottom of the slope and work up.
- It is recommended that pilot holes be driven through the fiber roll. Use a straight bar to drive holes through the roll and into the soil for the wooden stakes.
- Turn the ends of the fiber roll up slope to prevent runoff from going around the roll.
- Stake fiber rolls into the trench.
 - Drive stakes at the end of each fiber roll and spaced 4 ft maximum on center.
 - Use wood stakes with a nominal classification of 0.75 by 0.75 in. and minimum length of 24 in.
- If more than one fiber roll is placed in a row, the rolls should be overlapped, not abutted.
- See typical fiber roll installation details at the end of this fact sheet.

Removal

- Fiber rolls can be left in place or removed depending on the type of fiber roll and application (temporary vs. permanent installation). Typically, fiber rolls encased with plastic netting are used for a temporary application because the netting does not biodegrade. Fiber rolls used in a permanent application are typically encased with a biodegradable material and are left in place. Removal of a fiber roll used in a permanent application can result in greater disturbance.
- Temporary installations should only be removed when up gradient areas are stabilized per General Permit requirements, and/or pollutant sources no longer present a hazard. But, they should also be removed before vegetation becomes too mature so that the removal process does not disturb more soil and vegetation than is necessary.

Costs

Material costs for regular fiber rolls range from \$20 - \$30 per 25 ft roll.

Material costs for PAM impregnated fiber rolls range between 7.00-\$9.00 per linear foot, based upon vendor research.

Inspection and Maintenance

- BMPs must be inspected in accordance with General Permit requirements for the associated project type and risk level. It is recommended that at a minimum, BMPs be inspected weekly, prior to forecasted rain events, daily during extended rain events, and after the conclusion of rain events.
- Repair or replace split, torn, unraveling, or slumping fiber rolls.
- If the fiber roll is used as a sediment capture device, or as an erosion control device to maintain sheet flows, sediment that accumulates in the BMP should be periodically removed

Fiber Rolls

SE-5

in order to maintain BMP effectiveness. Sediment should be removed when sediment accumulation reaches one-third the designated sediment storage depth.

- If fiber rolls are used for erosion control, such as in a check dam, sediment removal should not be required as long as the system continues to control the grade. Sediment control BMPs will likely be required in conjunction with this type of application.
- Repair any rills or gullies promptly.

References

Stormwater Quality Handbooks - Construction Site Best Management Practices (BMPs) Manual, State of California Department of Transportation (Caltrans), March 2003.

Erosion and Sediment Control Manual, Oregon Department of Environmental Quality, February 2005.

Fiber Rolls

SE-5

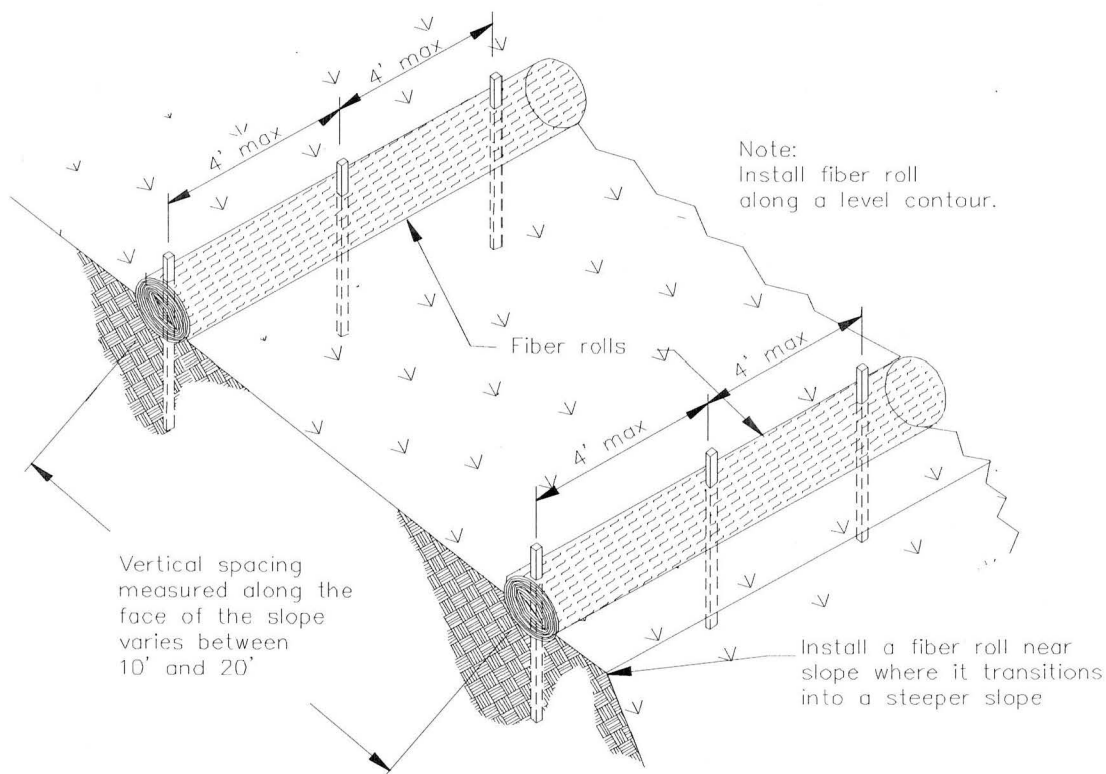

TYPICAL FIBER ROLL INSTALLATION

N.T.S.

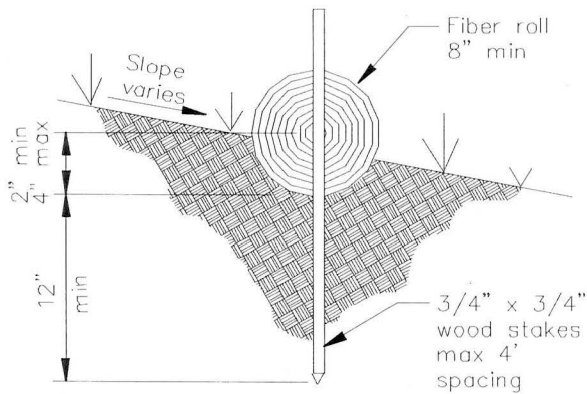

ENTRENCHMENT DETAIL

N.T.S.

Violation No. 8

Failure to Manage Run-On and Runoff
(7 days)

Sandbag Barrier

SE-8

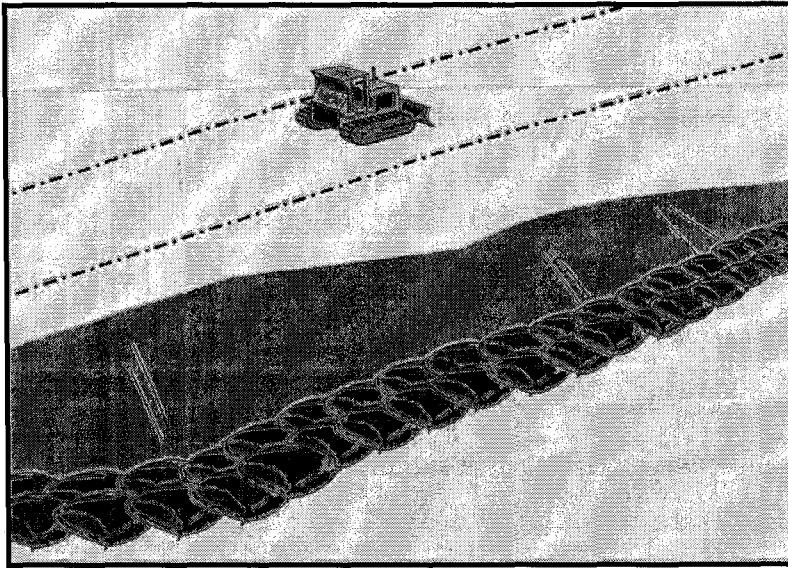

Categories

EC	Erosion Control	<input checked="" type="checkbox"/>
SE	Sediment Control	<input checked="" type="checkbox"/>
TC	Tracking Control	
WE	Wind Erosion Control	
NS	Non-Stormwater Management Control	
WM	Waste Management and Materials Pollution Control	

Legend:

- Primary Category
- Secondary Category

Description and Purpose

A sandbag barrier is a series of sand-filled bags placed on a level contour to intercept or to divert sheet flows. Sandbag barriers placed on a level contour pond sheet flow runoff, allowing sediment to settle out.

Suitable Applications

Sandbag barriers may be suitable:

- As a linear sediment control measure:
 - Below the toe of slopes and erodible slopes.
 - As sediment traps at culvert/pipe outlets.
 - Below other small cleared areas.
 - Along the perimeter of a site.
 - Down slope of exposed soil areas.
 - Around temporary stockpiles and spoil areas.
 - Parallel to a roadway to keep sediment off paved areas.
 - Along streams and channels.
- As linear erosion control measure:
 - Along the face and at grade breaks of exposed and erodible slopes to shorten slope length and spread runoff as sheet flow.

Targeted Constituents

Sediment	<input checked="" type="checkbox"/>
Nutrients	
Trash	
Metals	
Bacteria	
Oil and Grease	
Organics	

Potential Alternatives

- SE-1 Silt Fence
- SE-5 Fiber Rolls
- SE-6 Gravel Bag Berm
- SE-14 Biofilter Bags



Sandbag Barrier

SE-8

- At the top of slopes to divert runoff away from disturbed slopes.
- As check dams across mildly sloped construction roads.

Limitations

- It is necessary to limit the drainage area upstream of the barrier to 5 acres.
- Sandbags are not intended to be used as filtration devices.
- Easily damaged by construction equipment.
- Degraded sandbags may rupture when removed, spilling sand.
- Sand is easily transported by runoff if bag is damaged or ruptured.
- Installation can be labor intensive.
- Durability of sandbags is somewhat limited and bags may need to be replaced when installation is required for longer than 6 months. When used to detain concentrated flows, maintenance requirements increase.
- Burlap should not be used for sandbags.

Implementation

General

A sandbag barrier consists of a row of sand-filled bags placed on a level contour. When appropriately placed, a sandbag barrier intercepts and slows sheet flow runoff, causing temporary ponding. The temporary ponding allows sediment to settle. Sand-filled bags have limited porosity, which is further limited as the fine sand tends to quickly plug with sediment, limiting or completely blocking the rate of flow through the barrier. If a porous barrier is desired, consider SE-1, Silt Fence, SE-5, Fiber Rolls, SE-6, Gravel Bag Berms or SE-14, Biofilter Bags. Sandbag barriers also interrupt the slope length and thereby reduce erosion by reducing the tendency of sheet flows to concentrate into rivulets which erode rills, and ultimately gullies, into disturbed, sloped soils. Sandbag barriers are similar to gravel bag berms, but less porous. Generally, sandbag barriers should be used in conjunction with temporary soil stabilization controls up slope to provide effective erosion and sediment control.

Design and Layout

- Locate sandbag barriers on a level contour.
- When used for slope interruption, the following slope/sheet flow length combinations apply:
 - Slope inclination of 4:1 (H:V) or flatter: Sandbags should be placed at a maximum interval of 20 ft, with the first row near the slope toe.
 - Slope inclination between 4:1 and 2:1 (H:V): Sandbags should be placed at a maximum interval of 15 ft. (a closer spacing is more effective), with the first row near the slope toe.
 - Slope inclination 2:1 (H:V) or greater: Sandbags should be placed at a maximum interval of 10 ft. (a closer spacing is more effective), with the first row near the slope toe.

Sandbag Barrier

SE-8

- Turn the ends of the sandbag barrier up slope to prevent runoff from going around the barrier.
- Allow sufficient space up slope from the barrier to allow ponding, and to provide room for sediment storage.
- For installation near the toe of the slope, sand bag barriers should be set back from the slope toe to facilitate cleaning. Where specific site conditions do not allow for a set-back, the sand bag barrier may be constructed on the toe of the slope. To prevent flows behind the barrier, bags can be placed perpendicular to a berm to serve as cross barriers.
- Drainage area should not exceed 5 acres.
- Stack sandbags at least three bags high.
- Butt ends of bags tightly.
- Overlap butt joints of row beneath with each successive row.
- Use a pyramid approach when stacking bags.
- In non-traffic areas
 - Height = 18 in. maximum
 - Top width = 24 in. minimum for three or more layer construction
 - Side slope = 2:1 (H:V) or flatter
- In construction traffic areas
 - Height = 12 in. maximum
 - Top width = 24 in. minimum for three or more layer construction.
 - Side slopes = 2:1 (H:V) or flatter.
- See typical sandbag barrier installation details at the end of this fact sheet.

Materials

- **Sandbag Material:** Sandbag should be woven polypropylene, polyethylene or polyamide fabric, minimum unit weight of 4 ounces/yd², Mullen burst strength exceeding 300 lb/in² in conformance with the requirements in ASTM designation D3786, and ultraviolet stability exceeding 70% in conformance with the requirements in ASTM designation D4355. Use of burlap is not an acceptable substitute, as sand can more easily mobilize out of burlap.
- **Sandbag Size:** Each sand-filled bag should have a length of 18 in., width of 12 in., thickness of 3 in., and mass of approximately 33 lbs. Bag dimensions are nominal, and may vary based on locally available materials.

Sandbag Barrier

SE-8

- **Fill Material:** All sandbag fill material should be non-cohesive, Class 3 (Caltrans Standard Specification, Section 25) permeable material free from clay and deleterious material, such as recycled concrete or asphalt..

Costs

Empty sandbags cost \$0.25 - \$0.75. Average cost of fill material is \$8 per yd³. Additional labor is required to fill the bags. Pre-filled sandbags are more expensive at \$1.50 - \$2.00 per bag. These costs are based upon vendor research.

Inspection and Maintenance

- BMPs must be inspected in accordance with General Permit requirements for the associated project type and risk level. It is recommended that at a minimum, BMPs be inspected weekly, prior to forecasted rain events, daily during extended rain events, and after the conclusion of rain events.
- Sandbags exposed to sunlight will need to be replaced every two to three months due to degradation of the bags.
- Reshape or replace sandbags as needed.
- Repair washouts or other damage as needed.
- Sediment that accumulates behind the BMP should be periodically removed in order to maintain BMP effectiveness. Sediment should be removed when the sediment accumulation reaches one-third of the barrier height.
- Remove sandbags when no longer needed and recycle sand fill whenever possible and properly dispose of bag material. Remove sediment accumulation, and clean, re-grade, and stabilize the area.

References

Standard Specifications for Construction of Local Streets and Roads, California Department of Transportation (Caltrans), July 2002.

Stormwater Quality Handbooks - Construction Site Best Management Practices (BMPs) Manual, State of California Department of Transportation (Caltrans), March 2003.

Erosion and Sediment Control Manual, Oregon Department of Environmental Quality, February 2005.

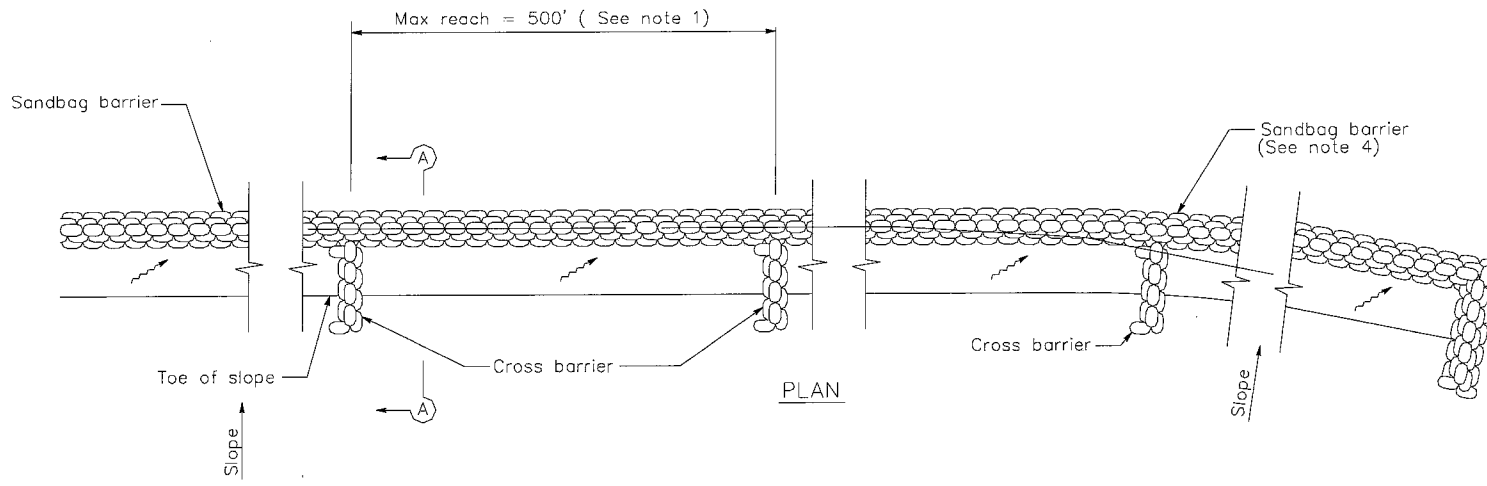

SANDBAG BARRIER

NOTES

1. Construct the length of each reach so that the change in base elevation along the reach does not exceed $1/2$ the height of the linear barrier. In no case shall the reach length exceed 500'.
2. Place sandbags tightly.
3. Dimension may vary to fit field condition.
4. Sandbag barrier shall be a minimum of 3 bags high.
5. The end of the barrier shall be turned up slope.
6. Cross barriers shall be a min of $1/2$ and a max of $2/3$ the height of the linear barrier.
7. Sandbag rows and layers shall be staggered to eliminate gaps.

Sandbag Barrier

SE-8

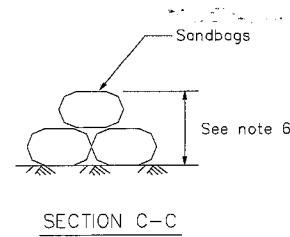
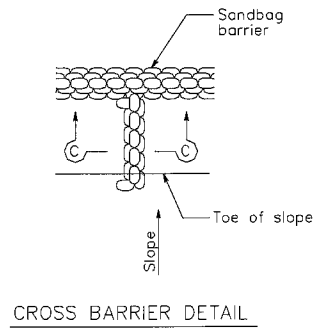
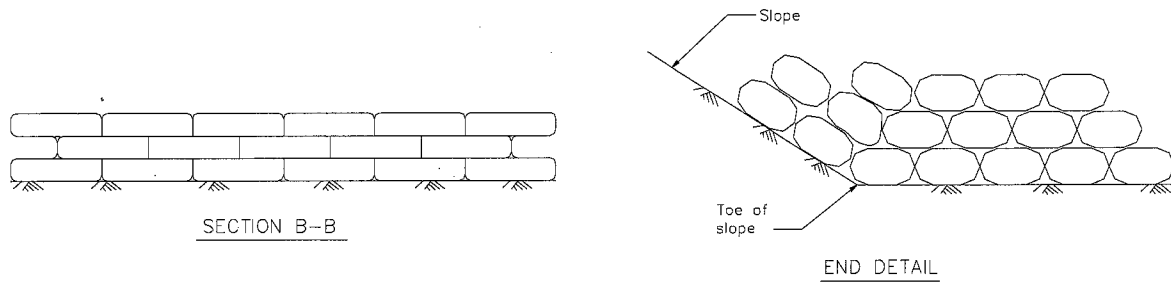
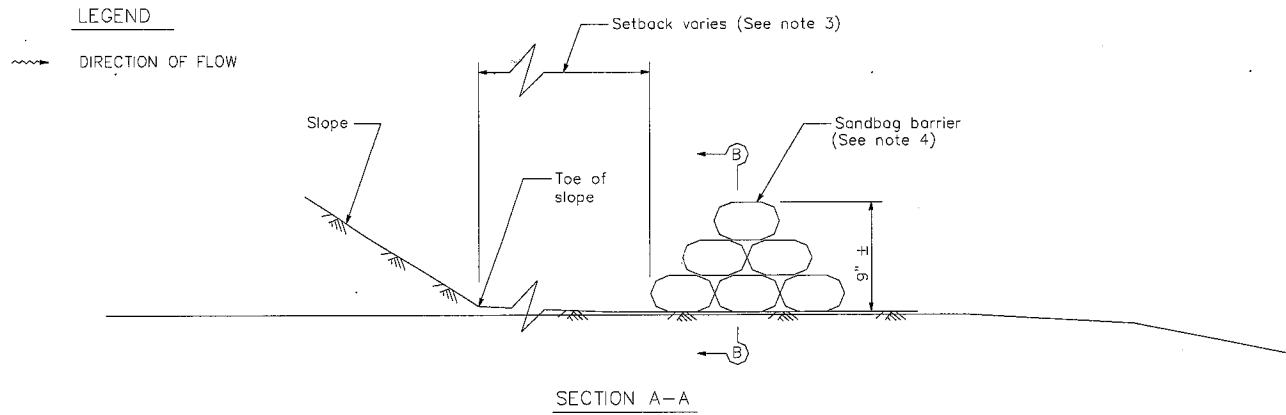

Fiber Rolls

SE-5

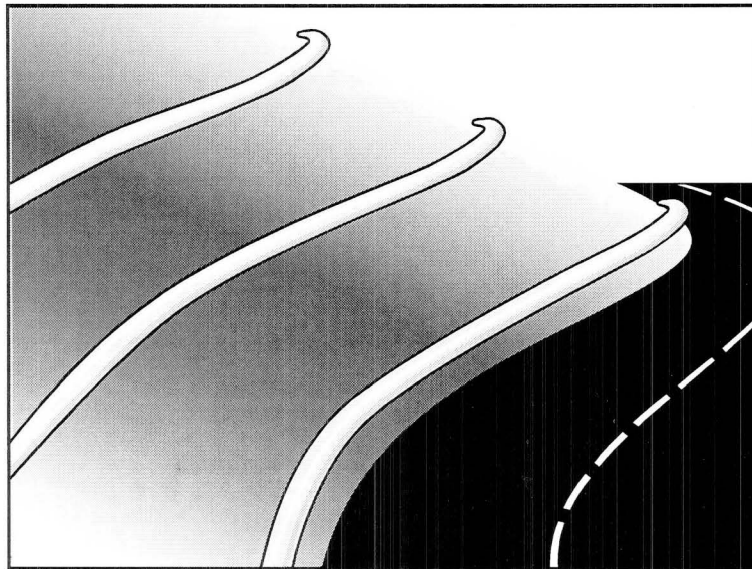

Description and Purpose

A fiber roll consists of straw, coir, or other biodegradable materials bound into a tight tubular roll wrapped by netting, which can be photodegradable or natural. Additionally, gravel core fiber rolls are available, which contain an imbedded ballast material such as gravel or sand for additional weight when staking the rolls are not feasible (such as use as inlet protection). When fiber rolls are placed at the toe and on the face of slopes along the contours, they intercept runoff, reduce its flow velocity, release the runoff as sheet flow, and provide removal of sediment from the runoff (through sedimentation). By interrupting the length of a slope, fiber rolls can also reduce sheet and rill erosion until vegetation is established.

Suitable Applications

Fiber rolls may be suitable:

- Along the toe, top, face, and at grade breaks of exposed and erodible slopes to shorten slope length and spread runoff as sheet flow.
- At the end of a downward slope where it transitions to a steeper slope.
- Along the perimeter of a project.
- As check dams in unlined ditches with minimal grade.
- Down-slope of exposed soil areas.
- At operational storm drains as a form of inlet protection.

Categories

EC	Erosion Control	<input checked="" type="checkbox"/>
SE	Sediment Control	<input checked="" type="checkbox"/>
TC	Tracking Control	
WE	Wind Erosion Control	
NS	Non-Stormwater Management Control	
WM	Waste Management and Materials Pollution Control	

Legend:

- Primary Category
- Secondary Category

Targeted Constituents

Sediment	<input checked="" type="checkbox"/>
Nutrients	
Trash	
Metals	
Bacteria	
Oil and Grease	
Organics	

Potential Alternatives

- SE-1 Silt Fence
- SE-6 Gravel Bag Berm
- SE-8 Sandbag Barrier
- SE-14 Biofilter Bags



Fiber Rolls

SE-5

- Around temporary stockpiles.

Limitations

- Fiber rolls are not effective unless trenched in and staked.
- Not intended for use in high flow situations.
- Difficult to move once saturated.
- If not properly staked and trenched in, fiber rolls could be transported by high flows.
- Fiber rolls have a very limited sediment capture zone.
- Fiber rolls should not be used on slopes subject to creep, slumping, or landslide.
- Rolls typically function for 12-24 months depending upon local conditions.

Implementation

Fiber Roll Materials

- Fiber rolls should be prefabricated.
- Fiber rolls may come manufactured containing polyacrylamide (PAM), a flocculating agent within the roll. Fiber rolls impregnated with PAM provide additional sediment removal capabilities and should be used in areas with fine, clayey or silty soils to provide additional sediment removal capabilities. Monitoring may be required for these installations.
- Fiber rolls are made from weed free rice straw, flax, or a similar agricultural material bound into a tight tubular roll by netting.
- Typical fiber rolls vary in diameter from 9 in. to 20 in. Larger diameter rolls are available as well.

Installation

- Locate fiber rolls on level contours spaced as follows:
 - Slope inclination of 4:1 (H:V) or flatter: Fiber rolls should be placed at a maximum interval of 20 ft.
 - Slope inclination between 4:1 and 2:1 (H:V): Fiber Rolls should be placed at a maximum interval of 15 ft. (a closer spacing is more effective).
 - Slope inclination 2:1 (H:V) or greater: Fiber Rolls should be placed at a maximum interval of 10 ft. (a closer spacing is more effective).
- Prepare the slope before beginning installation.
- Dig small trenches across the slope on the contour. The trench depth should be 1/4 to 1/3 of the thickness of the roll, and the width should equal the roll diameter, in order to provide area to backfill the trench.

Fiber Rolls

SE-5

- It is critical that rolls are installed perpendicular to water movement, and parallel to the slope contour.
- Start building trenches and installing rolls from the bottom of the slope and work up.
- It is recommended that pilot holes be driven through the fiber roll. Use a straight bar to drive holes through the roll and into the soil for the wooden stakes.
- Turn the ends of the fiber roll up slope to prevent runoff from going around the roll.
- Stake fiber rolls into the trench.
 - Drive stakes at the end of each fiber roll and spaced 4 ft maximum on center.
 - Use wood stakes with a nominal classification of 0.75 by 0.75 in. and minimum length of 24 in.
- If more than one fiber roll is placed in a row, the rolls should be overlapped, not abutted.
- See typical fiber roll installation details at the end of this fact sheet.

Removal

- Fiber rolls can be left in place or removed depending on the type of fiber roll and application (temporary vs. permanent installation). Typically, fiber rolls encased with plastic netting are used for a temporary application because the netting does not biodegrade. Fiber rolls used in a permanent application are typically encased with a biodegradable material and are left in place. Removal of a fiber roll used in a permanent application can result in greater disturbance.
- Temporary installations should only be removed when up gradient areas are stabilized per General Permit requirements, and/or pollutant sources no longer present a hazard. But, they should also be removed before vegetation becomes too mature so that the removal process does not disturb more soil and vegetation than is necessary.

Costs

Material costs for regular fiber rolls range from \$20 - \$30 per 25 ft roll.

Material costs for PAM impregnated fiber rolls range between 7.00-\$9.00 per linear foot, based upon vendor research.

Inspection and Maintenance

- BMPs must be inspected in accordance with General Permit requirements for the associated project type and risk level. It is recommended that at a minimum, BMPs be inspected weekly, prior to forecasted rain events, daily during extended rain events, and after the conclusion of rain events.
- Repair or replace split, torn, unraveling, or slumping fiber rolls.
- If the fiber roll is used as a sediment capture device, or as an erosion control device to maintain sheet flows, sediment that accumulates in the BMP should be periodically removed

Fiber Rolls

SE-5

in order to maintain BMP effectiveness. Sediment should be removed when sediment accumulation reaches one-third the designated sediment storage depth.

- If fiber rolls are used for erosion control, such as in a check dam, sediment removal should not be required as long as the system continues to control the grade. Sediment control BMPs will likely be required in conjunction with this type of application.
- Repair any rills or gullies promptly.

References

Stormwater Quality Handbooks - Construction Site Best Management Practices (BMPs) Manual, State of California Department of Transportation (Caltrans), March 2003.

Erosion and Sediment Control Manual, Oregon Department of Environmental Quality, February 2005.

Fiber Rolls

SE-5

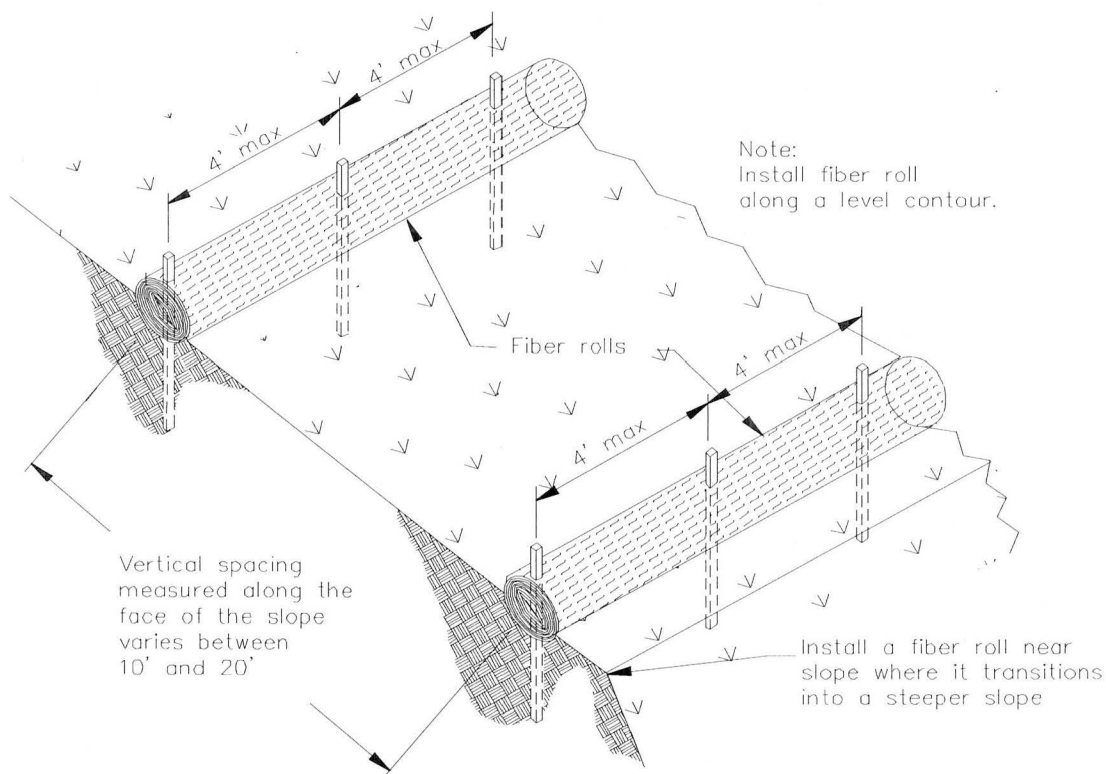

TYPICAL FIBER ROLL INSTALLATION

N.T.S.

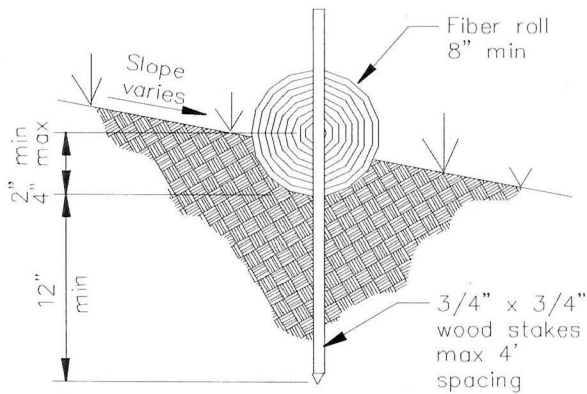

ENTRENCHMENT DETAIL

N.T.S.

Violation No. 9

Failure to Remove Sediment or Other
Construction Materials from Roads
(10 days)

Street Sweeping and Vacuuming SE-7

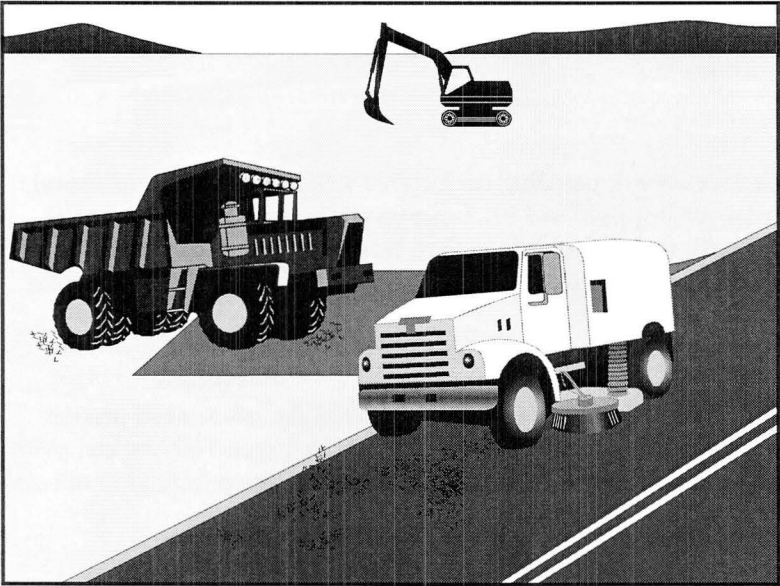

Description and Purpose

Street sweeping and vacuuming includes use of self-propelled and walk-behind equipment to remove sediment from streets and roadways, and to clean paved surfaces in preparation for final paving. Sweeping and vacuuming prevents sediment from the project site from entering storm drains or receiving waters.

Suitable Applications

Sweeping and vacuuming are suitable anywhere sediment is tracked from the project site onto public or private paved streets and roads, typically at points of egress. Sweeping and vacuuming are also applicable during preparation of paved surfaces for final paving.

Limitations

Sweeping and vacuuming may not be effective when sediment is wet or when tracked soil is caked (caked soil may need to be scraped loose).

Implementation

- Controlling the number of points where vehicles can leave the site will allow sweeping and vacuuming efforts to be focused, and perhaps save money.
- Inspect potential sediment tracking locations daily.
- Visible sediment tracking should be swept or vacuumed on a daily basis.
- Do not use kick brooms or sweeper attachments. These tend to spread the dirt rather than remove it.

Categories

EC	Erosion Control	
SE	Sediment Control	<input checked="" type="checkbox"/>
TC	Tracking Control	<input checked="" type="checkbox"/>
WE	Wind Erosion Control	
NS	Non-Stormwater Management Control	
WM	Waste Management and Materials Pollution Control	

Legend:

- Primary Objective
- Secondary Objective

Targeted Constituents

Sediment	<input checked="" type="checkbox"/>
Nutrients	
Trash	<input checked="" type="checkbox"/>
Metals	
Bacteria	
Oil and Grease	<input checked="" type="checkbox"/>
Organics	

Potential Alternatives

None



Street Sweeping and Vacuuming **SE-7**

- If not mixed with debris or trash, consider incorporating the removed sediment back into the project

Costs

Rental rates for self-propelled sweepers vary depending on hopper size and duration of rental. Expect rental rates from \$58/hour (3 yd³ hopper) to \$88/hour (9 yd³ hopper), plus operator costs. Hourly production rates vary with the amount of area to be swept and amount of sediment. Match the hopper size to the area and expect sediment load to minimize time spent dumping.

Inspection and Maintenance

- Inspect BMPs in accordance with General Permit requirements for the associated project type and risk level. It is recommended that at a minimum, BMPs be inspected weekly, prior to forecasted rain events, daily during extended rain events, and after the conclusion of rain events.
- When actively in use, points of ingress and egress must be inspected daily.
- When tracked or spilled sediment is observed outside the construction limits, it must be removed at least daily. More frequent removal, even continuous removal, may be required in some jurisdictions.
- Be careful not to sweep up any unknown substance or any object that may be potentially hazardous.
- Adjust brooms frequently; maximize efficiency of sweeping operations.
- After sweeping is finished, properly dispose of sweeper wastes at an approved dumpsite.

References

Stormwater Quality Handbooks - Construction Site Best Management Practices (BMPs) Manual, State of California Department of Transportation (Caltrans), November 2000.

Labor Surcharge and Equipment Rental Rates, State of California Department of Transportation (Caltrans), April 1, 2002 – March 31, 2003.

Violation No. 10

Failure to Protect Storm Drain Inlets
(3 days)

Storm Drain Inlet Protection

SE-10

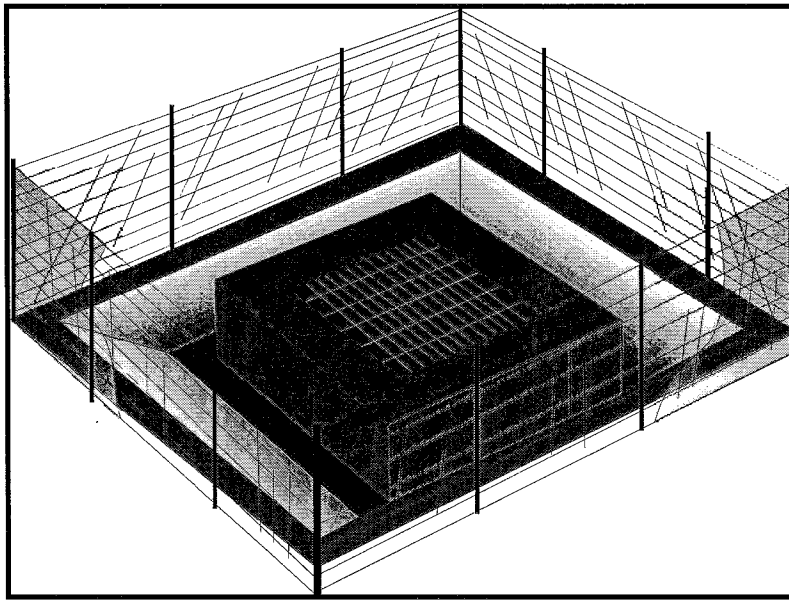

Description and Purpose

Storm drain inlet protection consists of a sediment filter or an impounding area in, around or upstream of a storm drain, drop inlet, or curb inlet. Storm drain inlet protection measures temporarily pond runoff before it enters the storm drain, allowing sediment to settle. Some filter configurations also remove sediment by filtering, but usually the ponding action results in the greatest sediment reduction. Temporary geotextile storm drain inserts attach underneath storm drain grates to capture and filter storm water.

Suitable Applications

Every storm drain inlet receiving runoff from unstabilized or otherwise active work areas should be protected. Inlet protection should be used in conjunction with other erosion and sediment controls to prevent sediment-laden stormwater and non-stormwater discharges from entering the storm drain system.

Limitations

- Drainage area should not exceed 1 acre.
- In general straw bales should not be used as inlet protection.
- Requires an adequate area for water to pond without encroaching into portions of the roadway subject to traffic.

Categories

EC	Erosion Control	
SE	Sediment Control	<input checked="" type="checkbox"/>
TC	Tracking Control	
WE	Wind Erosion Control	
NS	Non-Stormwater Management Control	
WM	Waste Management and Materials Pollution Control	

Legend:

- Primary Category
- Secondary Category

Targeted Constituents

Sediment	<input checked="" type="checkbox"/>
Nutrients	
Trash	<input checked="" type="checkbox"/>
Metals	
Bacteria	
Oil and Grease	
Organics	

Potential Alternatives

- SE-1 Silt Fence
- SE-5 Fiber Rolls
- SE-6 Gravel Bag Berm
- SE-8 Sandbag Barrier
- SE-14 Biofilter Bags

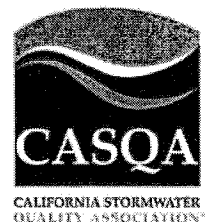

Storm Drain Inlet Protection

SE-10

- Sediment removal may be inadequate to prevent sediment discharges in high flow conditions or if runoff is heavily sediment laden. If high flow conditions are expected, use other onsite sediment trapping techniques in conjunction with inlet protection.
- Frequent maintenance is required.
- Limit drainage area to 1 acre maximum. For drainage areas larger than 1 acre, runoff should be routed to a sediment-trapping device designed for larger flows. See BMPs SE-2, Sediment Basin, and SE-3, Sediment Traps.
- Excavated drop inlet sediment traps are appropriate where relatively heavy flows are expected, and overflow capability is needed.

Implementation

General

Inlet control measures presented in this handbook should not be used for inlets draining more than one acre. Runoff from larger disturbed areas should be first routed through SE-2, Sediment Basin or SE-3, Sediment Trap and/or used in conjunction with other drainage control, erosion control, and sediment control BMPs to protect the site. Different types of inlet protection are appropriate for different applications depending on site conditions and the type of inlet. Alternative methods are available in addition to the methods described/shown herein such as prefabricated inlet insert devices, or gutter protection devices.

Design and Layout

Identify existing and planned storm drain inlets that have the potential to receive sediment-laden surface runoff. Determine if storm drain inlet protection is needed and which method to use.

- The key to successful and safe use of storm drain inlet protection devices is to know where runoff that is directed toward the inlet to be protected will pond or be diverted as a result of installing the protection device.
 - Determine the acceptable location and extent of ponding in the vicinity of the drain inlet. The acceptable location and extent of ponding will influence the type and design of the storm drain inlet protection device.
 - Determine the extent of potential runoff diversion caused by the storm drain inlet protection device. Runoff ponded by inlet protection devices may flow around the device and towards the next downstream inlet. In some cases, this is acceptable; in other cases, serious erosion or downstream property damage can be caused by these diversions. The possibility of runoff diversions will influence whether or not storm drain inlet protection is suitable; and, if suitable, the type and design of the device.
- The location and extent of ponding, and the extent of diversion, can usually be controlled through appropriate placement of the inlet protection device. In some cases, moving the inlet protection device a short distance upstream of the actual inlet can provide more efficient sediment control, limit ponding to desired areas, and prevent or control diversions.

Storm Drain Inlet Protection

SE-10

- Six types of inlet protection are presented below. However, it is recognized that other effective methods and proprietary devices exist and may be selected.
 - Silt Fence: Appropriate for drainage basins with less than a 5% slope, sheet flows, and flows under 0.5 cfs.
 - Excavated Drop Inlet Sediment Trap: An excavated area around the inlet to trap sediment (SE-3).
 - Gravel bag barrier: Used to create a small sediment trap upstream of inlets on sloped, paved streets. Appropriate for sheet flow or when concentrated flow may exceed 0.5 cfs, and where overtopping is required to prevent flooding.
 - Block and Gravel Filter: Appropriate for flows greater than 0.5 cfs.
 - Temporary Geotextile Storm drain Inserts: Different products provide different features. Refer to manufacturer details for targeted pollutants and additional features.
 - Biofilter Bag Barrier: Used to create a small retention area upstream of inlets and can be located on pavement or soil. Biofilter bags slowly filter runoff allowing sediment to settle out. Appropriate for flows under 0.5 cfs.
- Select the appropriate type of inlet protection and design as referred to or as described in this fact sheet.
- Provide area around the inlet for water to pond without flooding structures and property.
- Grates and spaces around all inlets should be sealed to prevent seepage of sediment-laden water.
- Excavate sediment sumps (where needed) 1 to 2 ft with 2:1 side slopes around the inlet.

Installation

- **DI Protection Type 1 - Silt Fence** - Similar to constructing a silt fence; see BMP SE-1, Silt Fence. Do not place fabric underneath the inlet grate since the collected sediment may fall into the drain inlet when the fabric is removed or replaced and water flow through the grate will be blocked resulting in flooding. See typical Type 1 installation details at the end of this fact sheet.
 1. Excavate a trench approximately 6 in. wide and 6 in. deep along the line of the silt fence inlet protection device.
 2. Place 2 in. by 2 in. wooden stakes around the perimeter of the inlet a maximum of 3 ft apart and drive them at least 18 in. into the ground or 12 in. below the bottom of the trench. The stakes should be at least 48 in.
 3. Lay fabric along bottom of trench, up side of trench, and then up stakes. See SE-1, Silt Fence, for details. The maximum silt fence height around the inlet is 24 in.
 4. Staple the filter fabric (for materials and specifications, see SE-1, Silt Fence) to wooden stakes. Use heavy-duty wire staples at least 1 in. in length.

Storm Drain Inlet Protection

SE-10

5. Backfill the trench with gravel or compacted earth all the way around.
- **DI Protection Type 2 - Excavated Drop Inlet Sediment Trap** - Install filter fabric fence in accordance with DI Protection Type 1. Size excavated trap to provide a minimum storage capacity calculated at the rate 67 yd³/acre of drainage area. See typical Type 2 installation details at the end of this fact sheet.
 - **DI Protection Type 3 - Gravel bag** - Flow from a severe storm should not overtop the curb. In areas of high clay and silts, use filter fabric and gravel as additional filter media. Construct gravel bags in accordance with SE-6, Gravel Bag Berm. Gravel bags should be used due to their high permeability. See typical Type 3 installation details at the end of this fact sheet.
 1. Construct on gently sloping street.
 2. Leave room upstream of barrier for water to pond and sediment to settle.
 3. Place several layers of gravel bags – overlapping the bags and packing them tightly together.
 4. Leave gap of one bag on the top row to serve as a spillway. Flow from a severe storm (e.g., 10 year storm) should not overtop the curb.
 - **DI Protection Type 4 – Block and Gravel Filter** - Block and gravel filters are suitable for curb inlets commonly used in residential, commercial, and industrial construction. See typical Type 4 installation details at the end of this fact sheet.
 1. Place hardware cloth or comparable wire mesh with 0.5 in. openings over the drop inlet so that the wire extends a minimum of 1 ft beyond each side of the inlet structure. If more than one strip is necessary, overlap the strips. Place woven geotextile over the wire mesh.
 2. Place concrete blocks lengthwise on their sides in a single row around the perimeter of the inlet, so that the open ends face outward, not upward. The ends of adjacent blocks should abut. The height of the barrier can be varied, depending on design needs, by stacking combinations of blocks that are 4 in., 8 in., and 12 in. wide. The row of blocks should be at least 12 in. but no greater than 24 in. high.
 3. Place wire mesh over the outside vertical face (open end) of the concrete blocks to prevent stone from being washed through the blocks. Use hardware cloth or comparable wire mesh with 0.5 in. opening.
 4. Pile washed stone against the wire mesh to the top of the blocks. Use 0.75 to 3 in.
 - **DI Protection Type 5 – Temporary Geotextile Insert (proprietary)** – Many types of temporary inserts are available. Most inserts fit underneath the grate of a drop inlet or inside of a curb inlet and are fastened to the outside of the grate or curb. These inserts are removable and many can be cleaned and reused. Installation of these inserts differs between manufacturers. Please refer to manufacturer instruction for installation of proprietary devices.

Storm Drain Inlet Protection

SE-10

- **DI Protection Type 6 - Biofilter bags** – Biofilter bags may be used as a substitute for gravel bags in low-flow situations. Biofilter bags should conform to specifications detailed in SE-14, Biofilter bags.
 1. Construct in a gently sloping area.
 2. Biofilter bags should be placed around inlets to intercept runoff flows.
 3. All bag joints should overlap by 6 in.
 4. Leave room upstream for water to pond and for sediment to settle out.
 5. Stake bags to the ground as described in the following detail. Stakes may be omitted if bags are placed on a paved surface.

Costs

- Average annual cost for installation and maintenance of DI Type 1-4 and 6 (one year useful life) is \$200 per inlet.
- Temporary geotextile inserts are proprietary and cost varies by region. These inserts can often be reused and may have greater than 1 year of use if maintained and kept undamaged. Average cost per insert ranges from \$50-75 plus installation, but costs can exceed \$100. This cost does not include maintenance.

Inspection and Maintenance

- BMPs must be inspected in accordance with General Permit requirements for the associated project type and risk level. It is recommended that at a minimum, BMPs be inspected weekly, prior to forecasted rain events, daily during extended rain events, and after the conclusion of rain events.
- Silt Fences. If the fabric becomes clogged, torn, or degrades, it should be replaced. Make sure the stakes are securely driven in the ground and are in good shape (i.e., not bent, cracked, or splintered, and are reasonably perpendicular to the ground). Replace damaged stakes. At a minimum, remove the sediment behind the fabric fence when accumulation reaches one-third the height of the fence or barrier height.
- Gravel Filters. If the gravel becomes clogged with sediment, it should be carefully removed from the inlet and either cleaned or replaced. Since cleaning gravel at a construction site may be difficult, consider using the sediment-laden stone as fill material and put fresh stone around the inlet. Inspect bags for holes, gashes, and snags, and replace bags as needed. Check gravel bags for proper arrangement and displacement.
- Sediment that accumulates in the BMP should be periodically removed in order to maintain BMP effectiveness. Sediment should be removed when the sediment accumulation reaches one-third of the barrier height.
- Inspect and maintain temporary geotextile insert devices according to manufacturer's specifications.
- Remove storm drain inlet protection once the drainage area is stabilized.

Storm Drain Inlet Protection

SE-10

- Clean and regrade area around the inlet and clean the inside of the storm drain inlet, as it should be free of sediment and debris at the time of final inspection.

References

Stormwater Quality Handbooks - Construction Site Best Management Practices (BMPs) Manual, State of California Department of Transportation (Caltrans), March 2003.

Stormwater Management Manual for The Puget Sound Basin, Washington State Department of Ecology, Public Review Draft, 1991.

Erosion and Sediment Control Manual, Oregon Department of Environmental Quality, February 2005.

Storm Drain Inlet Protection

SE-10

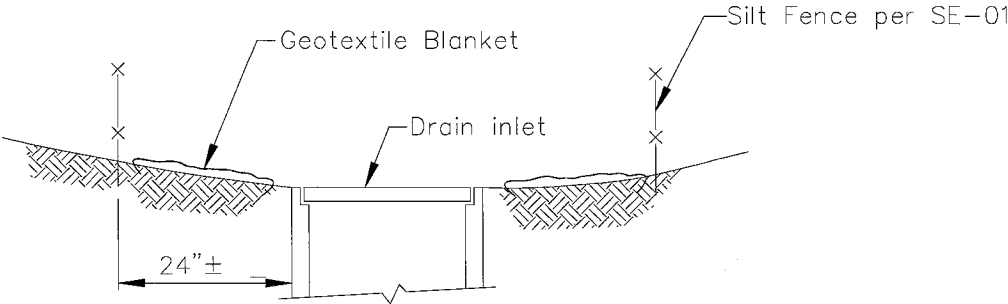

SECTION A-A

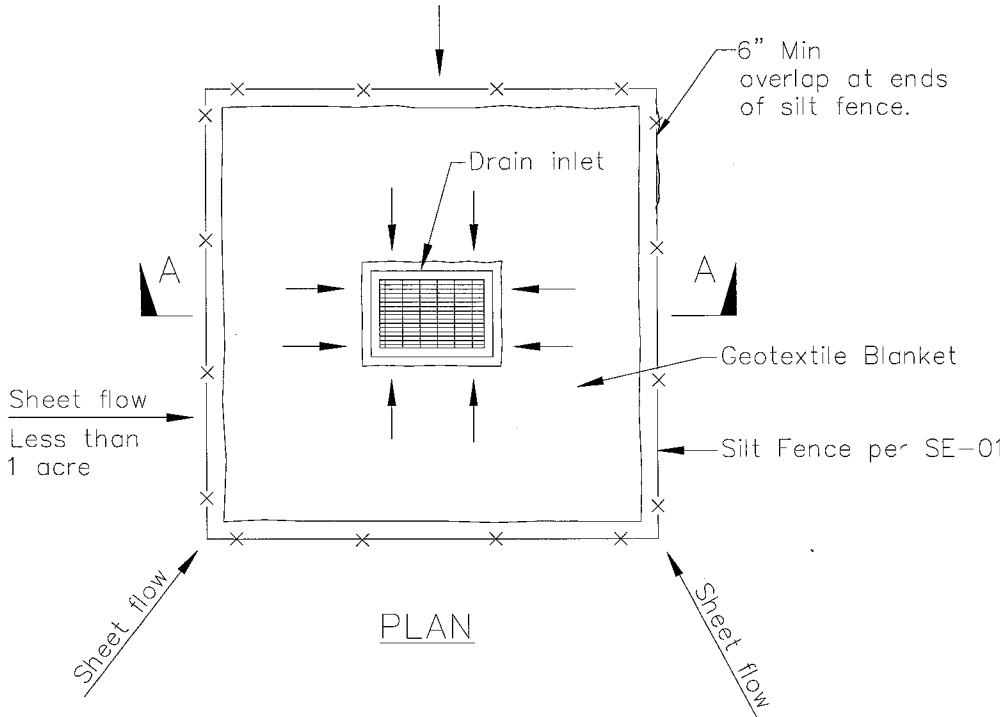

PLAN

DI PROTECTION TYPE 1
NOT TO SCALE

NOTES:

- 1. For use in areas where grading has been completed and final soil stabilization and seeding are pending.
- 2. Not applicable in paved areas.
- 3. Not applicable with concentrated flows.

Storm Drain Inlet Protection

SE-10

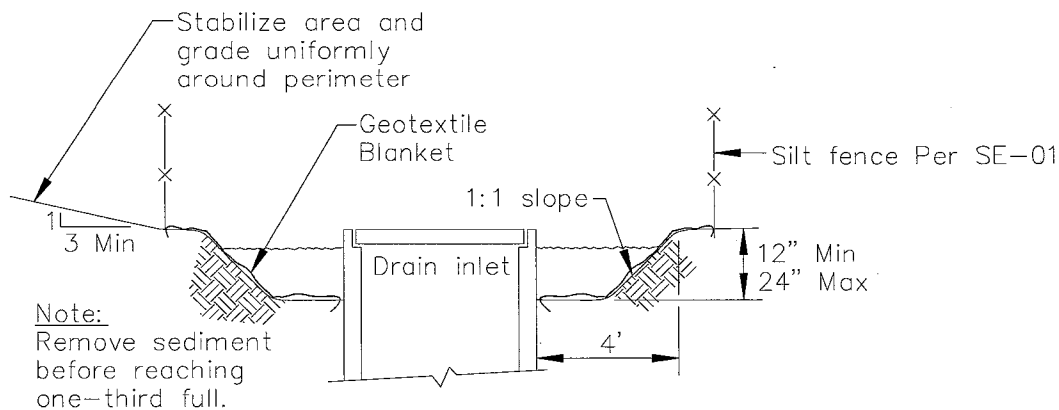

Section A-A

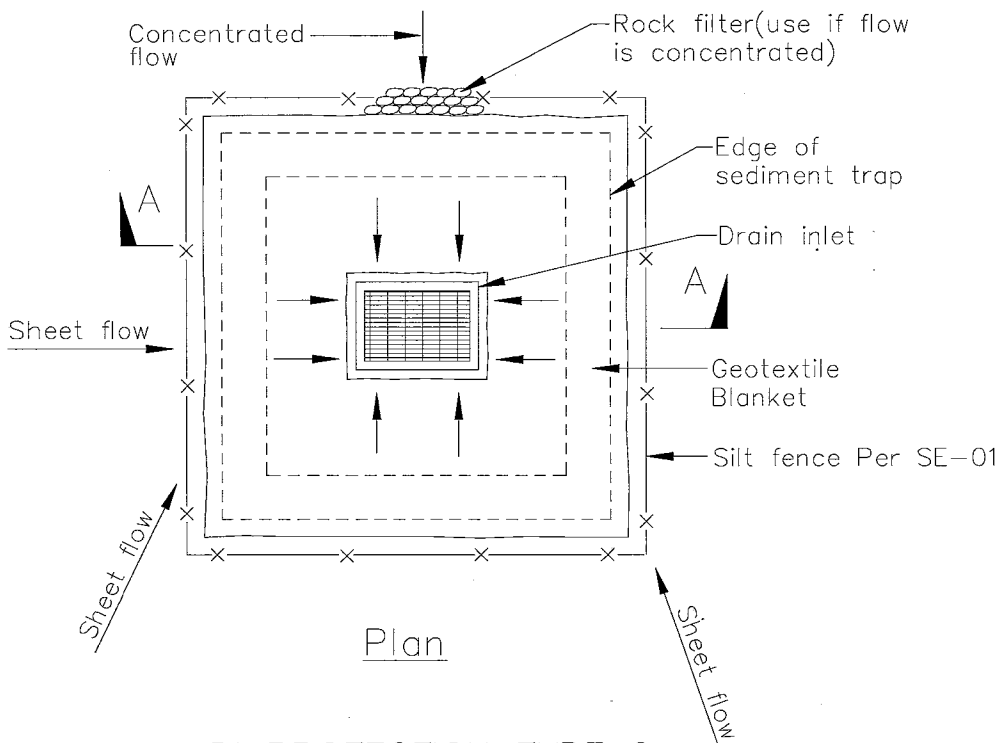

DI PROTECTION TYPE 2
 NOT TO SCALE

Notes

1. For use in cleared and grubbed and in graded areas.
2. Shape basin so that longest inflow area faces longest length of trap.
3. For concentrated flows, shape basin in 2:1 ratio with length oriented towards direction of flow.

Storm Drain Inlet Protection

SE-10

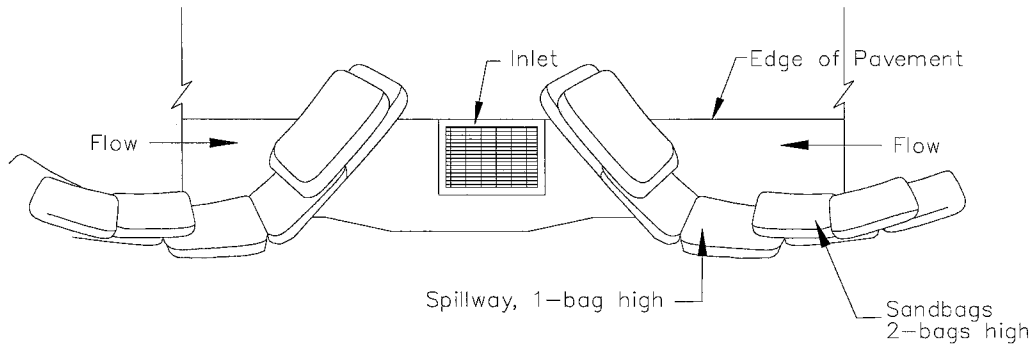

TYPICAL PROTECTION FOR INLET ON SUMP

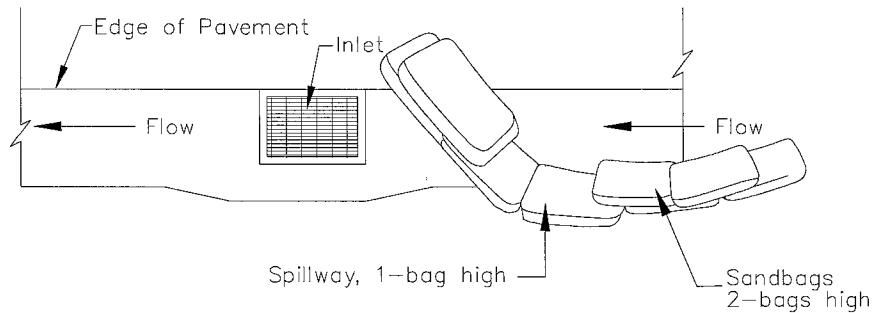

TYPICAL PROTECTION FOR INLET ON GRADE

NOTES:

1. Intended for short-term use.
2. Use to inhibit non-storm water flow.
3. Allow for proper maintenance and cleanup.
4. Bags must be removed after adjacent operation is completed.
5. Not applicable in areas with high silts and clays without filter fabric.

DI PROTECTION TYPE 3
NOT TO SCALE

Storm Drain Inlet Protection

SE-10

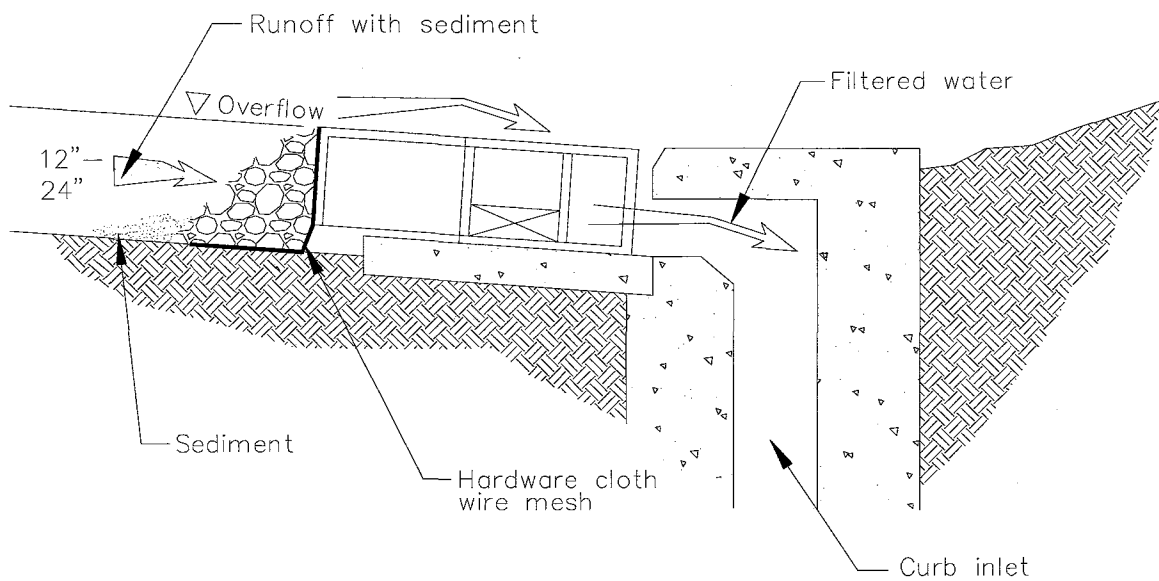
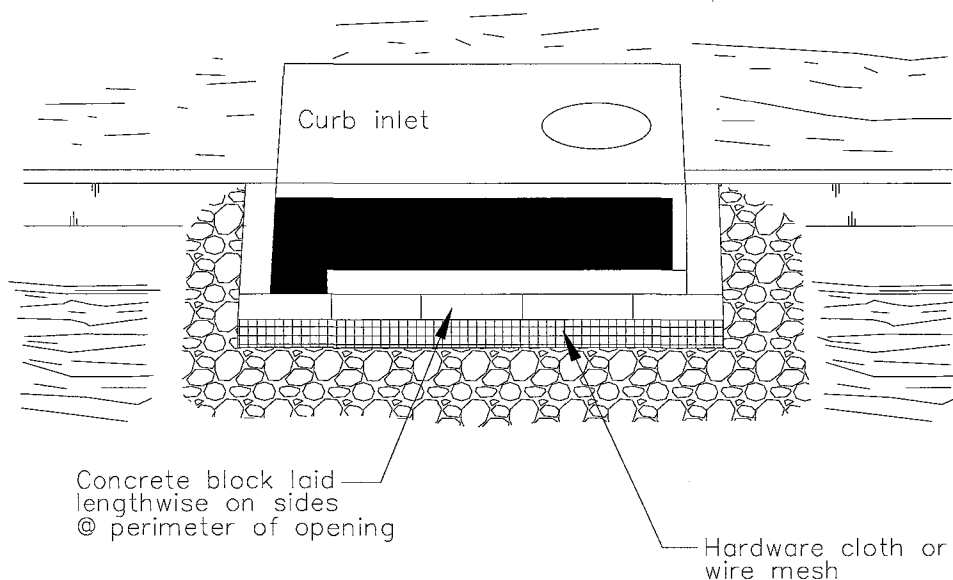

DI PROTECTION – TYPE 4
NOT TO SCALE

Violation No. 11

Failure to Contain and Securely Protect
Stockpiled Waste Material from Wind and Rain
(9 days)

Fiber Rolls

SE-5

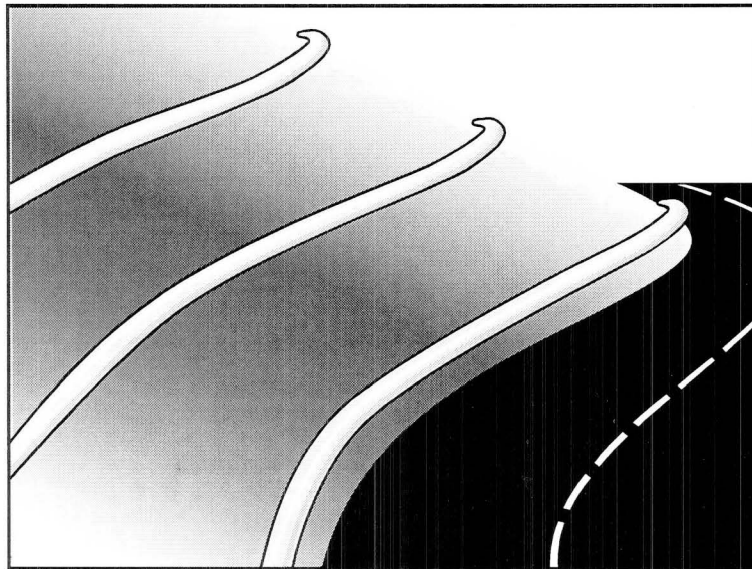

Description and Purpose

A fiber roll consists of straw, coir, or other biodegradable materials bound into a tight tubular roll wrapped by netting, which can be photodegradable or natural. Additionally, gravel core fiber rolls are available, which contain an imbedded ballast material such as gravel or sand for additional weight when staking the rolls are not feasible (such as use as inlet protection). When fiber rolls are placed at the toe and on the face of slopes along the contours, they intercept runoff, reduce its flow velocity, release the runoff as sheet flow, and provide removal of sediment from the runoff (through sedimentation). By interrupting the length of a slope, fiber rolls can also reduce sheet and rill erosion until vegetation is established.

Suitable Applications

Fiber rolls may be suitable:

- Along the toe, top, face, and at grade breaks of exposed and erodible slopes to shorten slope length and spread runoff as sheet flow.
- At the end of a downward slope where it transitions to a steeper slope.
- Along the perimeter of a project.
- As check dams in unlined ditches with minimal grade.
- Down-slope of exposed soil areas.
- At operational storm drains as a form of inlet protection.

Categories

EC	Erosion Control	<input checked="" type="checkbox"/>
SE	Sediment Control	<input checked="" type="checkbox"/>
TC	Tracking Control	
WE	Wind Erosion Control	
NS	Non-Stormwater Management Control	
WM	Waste Management and Materials Pollution Control	

Legend:

- Primary Category
- Secondary Category

Targeted Constituents

Sediment	<input checked="" type="checkbox"/>
Nutrients	
Trash	
Metals	
Bacteria	
Oil and Grease	
Organics	

Potential Alternatives

- SE-1 Silt Fence
- SE-6 Gravel Bag Berm
- SE-8 Sandbag Barrier
- SE-14 Biofilter Bags



Fiber Rolls

SE-5

- Around temporary stockpiles.

Limitations

- Fiber rolls are not effective unless trenched in and staked.
- Not intended for use in high flow situations.
- Difficult to move once saturated.
- If not properly staked and trenched in, fiber rolls could be transported by high flows.
- Fiber rolls have a very limited sediment capture zone.
- Fiber rolls should not be used on slopes subject to creep, slumping, or landslide.
- Rolls typically function for 12-24 months depending upon local conditions.

Implementation

Fiber Roll Materials

- Fiber rolls should be prefabricated.
- Fiber rolls may come manufactured containing polyacrylamide (PAM), a flocculating agent within the roll. Fiber rolls impregnated with PAM provide additional sediment removal capabilities and should be used in areas with fine, clayey or silty soils to provide additional sediment removal capabilities. Monitoring may be required for these installations.
- Fiber rolls are made from weed free rice straw, flax, or a similar agricultural material bound into a tight tubular roll by netting.
- Typical fiber rolls vary in diameter from 9 in. to 20 in. Larger diameter rolls are available as well.

Installation

- Locate fiber rolls on level contours spaced as follows:
 - Slope inclination of 4:1 (H:V) or flatter: Fiber rolls should be placed at a maximum interval of 20 ft.
 - Slope inclination between 4:1 and 2:1 (H:V): Fiber Rolls should be placed at a maximum interval of 15 ft. (a closer spacing is more effective).
 - Slope inclination 2:1 (H:V) or greater: Fiber Rolls should be placed at a maximum interval of 10 ft. (a closer spacing is more effective).
- Prepare the slope before beginning installation.
- Dig small trenches across the slope on the contour. The trench depth should be 1/4 to 1/3 of the thickness of the roll, and the width should equal the roll diameter, in order to provide area to backfill the trench.

Fiber Rolls

SE-5

- It is critical that rolls are installed perpendicular to water movement, and parallel to the slope contour.
- Start building trenches and installing rolls from the bottom of the slope and work up.
- It is recommended that pilot holes be driven through the fiber roll. Use a straight bar to drive holes through the roll and into the soil for the wooden stakes.
- Turn the ends of the fiber roll up slope to prevent runoff from going around the roll.
- Stake fiber rolls into the trench.
 - Drive stakes at the end of each fiber roll and spaced 4 ft maximum on center.
 - Use wood stakes with a nominal classification of 0.75 by 0.75 in. and minimum length of 24 in.
- If more than one fiber roll is placed in a row, the rolls should be overlapped, not abutted.
- See typical fiber roll installation details at the end of this fact sheet.

Removal

- Fiber rolls can be left in place or removed depending on the type of fiber roll and application (temporary vs. permanent installation). Typically, fiber rolls encased with plastic netting are used for a temporary application because the netting does not biodegrade. Fiber rolls used in a permanent application are typically encased with a biodegradable material and are left in place. Removal of a fiber roll used in a permanent application can result in greater disturbance.
- Temporary installations should only be removed when up gradient areas are stabilized per General Permit requirements, and/or pollutant sources no longer present a hazard. But, they should also be removed before vegetation becomes too mature so that the removal process does not disturb more soil and vegetation than is necessary.

Costs

Material costs for regular fiber rolls range from \$20 - \$30 per 25 ft roll.

Material costs for PAM impregnated fiber rolls range between 7.00-\$9.00 per linear foot, based upon vendor research.

Inspection and Maintenance

- BMPs must be inspected in accordance with General Permit requirements for the associated project type and risk level. It is recommended that at a minimum, BMPs be inspected weekly, prior to forecasted rain events, daily during extended rain events, and after the conclusion of rain events.
- Repair or replace split, torn, unraveling, or slumping fiber rolls.
- If the fiber roll is used as a sediment capture device, or as an erosion control device to maintain sheet flows, sediment that accumulates in the BMP should be periodically removed

Fiber Rolls

SE-5

in order to maintain BMP effectiveness. Sediment should be removed when sediment accumulation reaches one-third the designated sediment storage depth.

- If fiber rolls are used for erosion control, such as in a check dam, sediment removal should not be required as long as the system continues to control the grade. Sediment control BMPs will likely be required in conjunction with this type of application.
- Repair any rills or gullies promptly.

References

Stormwater Quality Handbooks - Construction Site Best Management Practices (BMPs) Manual, State of California Department of Transportation (Caltrans), March 2003.

Erosion and Sediment Control Manual, Oregon Department of Environmental Quality, February 2005.

Fiber Rolls

SE-5

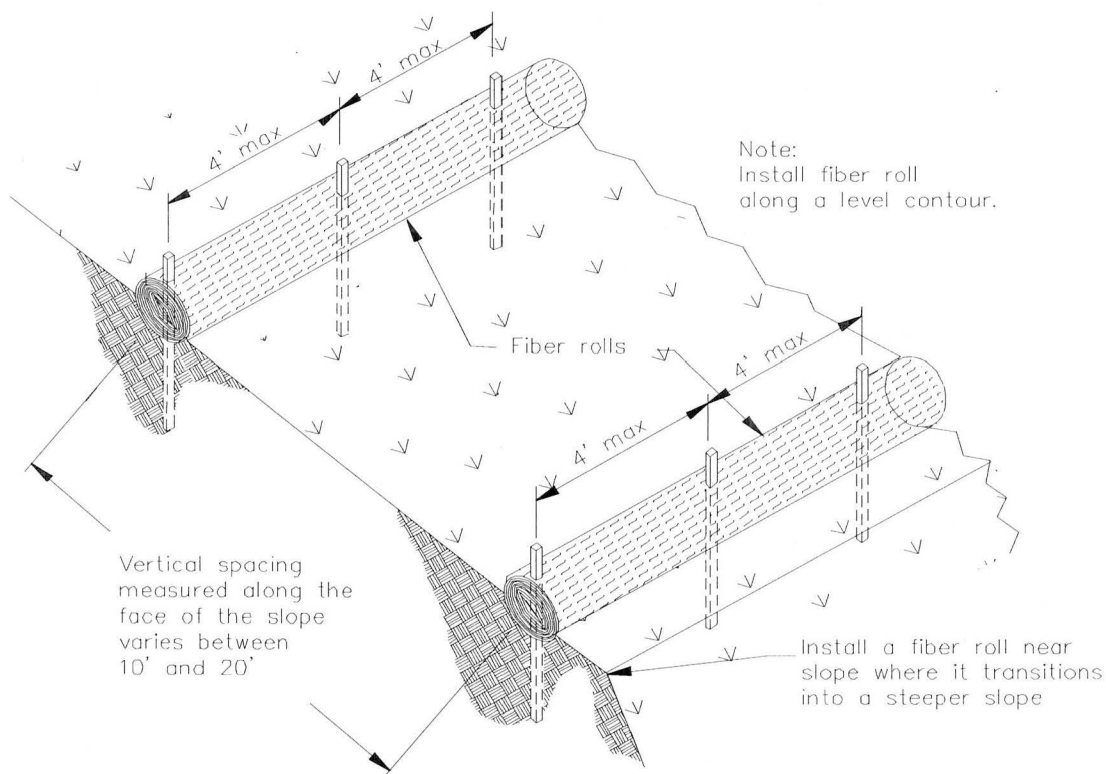

TYPICAL FIBER ROLL INSTALLATION

N.T.S.

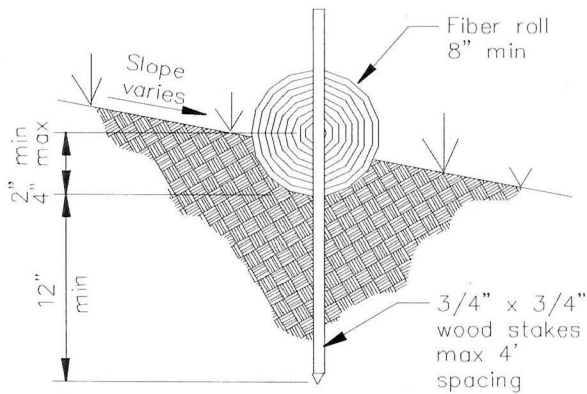

ENTRENCHMENT DETAIL

N.T.S.



Select Your Store

Help Center | Services | Credit Center | Gift Cards

Departments | Project Center | Promotions | Search All

Search bar with magnifying glass icon and Cart (0)

Home > Paint > Drop Cloths & Plastic Sheeting > Poly Film



Polar Plastics 6-Mil Clear Poly Reinforced Plastic Sheeting - 20' x 50' Roll

Model Number: 5680090 | Menards® SKU: 5680090
Variation: Clear

Online Price **\$74.98**



Online Availability

- Ship to Home
Available for immediate shipment
- Ship to Store - Free!

Quantity

Add to Cart

Add to My List

Description

- Add to Compare
- Add to Gift Registry

Click image for a larger view.
Hover to zoom in.

Description & Documents

For everything from simple dust protection to heavy-duty construction projects, Polar Plastics has a fitting solution. Their strong, durable plastics come in a variety of sizes, thicknesses and colors to perfectly meet the requirements of your project. This reinforced sheeting is the epitome of strength when it comes to plastic sheeting. With two layers of low-density polyethylene and hundreds of nylon strings forming a diamond scrim pattern, this sheeting makes a great long-term cover for heavy-duty equipment or the perfect dust and debris shield. Use as much or as little as you need!

- Two layers of low-density polyethylene with nylon strings running through and between
- Reinforced diamond scrim pattern is ideal for heavy-duty applications
- Commonly used for building enclosures, crawl spaces and as a long-lasting equipment cover
- Reinforced design stops tears and punctures
- Perfect for weather, water and dust protection
- Made in USA
- 6-mil thickness is the nominal size

Dimensions: 20' x 50'



MSDS Document: [101025_001.pdf](#) [106044_001.pdf](#)

To read PDF files, you need the Adobe Acrobat Reader 6.0 or higher. If you don't have it, [click here](#) and download it for free from Adobe's site.

Store Availability

Enter Your ZIP Code for Store Information

Guests Who Viewed This Item Also Viewed These Products



Polar Plastics 6-Mil Clear Poly All-Purpose Plastic Sheeting - 20' x 100' Roll

\$72.98



Polar Plastics 6-Mil Clear Poly Reinforced Plastic Sheeting - 12' x 100' Roll

\$84.98

Please Note: Prices, promotions, styles and availability may vary by store and online. While we do our best to provide accurate item availability information, we cannot guarantee in-stock status and availability as inventory is sold and received continuously throughout the day. Inventory last updated 8/17/2015 at 5:00am EST. Online orders and products purchased in-store qualify for rebate redemption. Rebates are provided in the form of a merchandise credit check which can only be used in a Menards® store.

Violation No. 12

Failure to Properly Store Chemicals
(7 days)

PIG® Poly Storage Shed

#PAK754 - Containment Shed • Use With Steel Drums Only • 75 gal. Sump Capacity



Stack two pallets of four drums each inside this storage shed to free up some floor space at your facility.

- Provides 75 gallons of containment and protected storage for up to eight 55-gallon drums (two stacked pallets)
- Low-density polyethylene (LDPE) construction with UV inhibitors resists UV rays, rust, corrosion and most chemicals
- Molded door vents help reduce fumes and interior condensation
- Removable grates provide easy access to the sump
- Forklift access from all sides makes the empty shed easy to move
- Lockable to help keep contents secure (lock included)



New Pig

By Phone:
1-855-493-HOGS

Online:
newpig.com

Email:
hothogs@newpig.com

One Pork Avenue • Tipton PA 16684-0304

© 2015 New Pig Corporation. All rights reserved.
PIG and the PIG logo are trademarks in the U.S. and other countries.

ITEM: PAK754 - Pg 1 of 3

PAK754 Product Option Information

Item #	Description	Dimensions	Weight	Pricing Qty: 1+
PAK754-BWG	Black with Gray	62.5" W x 90" D x 93" H	500 lbs.	\$3,213.00

Metric Equivalent

Item #	Description	Dimensions	Weight	Pricing Qty: 1+
PAK754-BWG	Black with Gray	158.8cm W x 2.3m D x 2.4m H	226.8 kg	\$3,213.00



By Phone:
1-855-493-HOGS

Online:
newpig.com

Email:
hothogs@newpig.com

New Pig

PAK754 Specifications

Load Capacity UDL:	8000 lbs.
Sump Capacity:	75 gal.
Access:	2 Hinged Doors
Containment Type:	Containment Shed
Fork Truck Access:	Four-way Fork Truck Access
Groundable for Flammables:	No
Interior Dimensions:	57" W x 78" H x 70" D
Number of Containers:	8 Drums
Type of Container:	Steel Drums Only
Sold as:	1 each
# per Pallet:	1
Composition:	Polyethylene
UNSPSC:	24101905

PAK754 Metric Equivalent

Load Capacity UDL:	3628.8 kg
Sump Capacity:	283.9 L

Technical Information

Warnings & Restrictions:

Flammables Notice
If using this product with flammable liquids, please consider the regulations that apply to storage and handling of flammable liquids and the safety of this application, specifically flammable vapors, static discharge and heat sources. For further assistance, please call Technical Services.

Regulations and Compliance:

40 CFR 264.175 - Hazardous waste containment systems must be free of structural cracks or gaps, be designed to keep spilled liquids from remaining in contact with the container, prevent run-on and "have sufficient capacity to contain 10% of the volume of the containers, or the volume of the largest container, whichever is greater."

40 CFR 122.26 - When applying for a National Pollutant Discharge Elimination System (NPDES) permit, facilities must have a plan in place that describes actions, procedures, control techniques, management practices and equipment available to prevent illegal discharge of pollutants into waterways.

40 CFR 112.7 - SPCC planning requirements state that facilities subject to these regulations must have written plans in place discussing the products, countermeasures and procedures that are in place, or will be taken by the facility to prevent discharge of oil into waters of the United States.

Technical Documents:

(Available at newpig.com)

Product Data Sheet (PDS)

Chemical Compatibility (CCG)



PAK754 Accessories

You might like...



Ramp for PIG® Poly Storage Shed

Item Number

PAK755



By Phone:
1-855-493-HOGS

Online:
newpig.com

Email:
hothogs@newpig.com

New Pig

Violation No. 13

Failure to Prevent Discharge of Concrete Waste
to the Ground
(15 days)

American CONCRETE WASHOUTS

1 (800) 788-0355

CONCRETE, PAINT & DRYWALL WASHOUT SERVICE PROVIDER

Contractors Choice



Concrete Washout (Ramped)

20' L X 8' W Ramps Folded
26' L X 8' W Ramps Extended
Capacity - 900 Gallons
Estimate 1 Washout for 350 Poured Yards of Concrete.
Used for Pump and Mixer Truck Washout.



Concrete Washout (Ramp less)

12' L X 8' W X 2' H
Capacity - 1300 Gallons
Limited Availability - Call for Info
Estimate 1 Washout for 400 Poured yards of concrete.



Washout Pan (Pump Truck Washout)

72" L x 72" W x 14"H
Capacity - 242 Gallons
Five Rigging "D" Rings
Angled Floor | Load Tested 25,000 LBS
Engineering Calculations Available
Currently Available in CA Only



Paint & Drywall Washouts

5' L X 4' W X 3' D
Capacity - 448 Gallons
Currently Not Available in Texas

American Concrete Washouts is a licensed, registered California public works #1000021973 Service Provider and Micro Small Business. We are an industry leading, permitted service provider for concrete, paint, drywall, tile, mortar, grout and stucco washout water.

Unlike any other washout service provider, we offer both the ramp & ramp less style EPA compliant, portable, watertight, patented Concrete Washout System (CWS).

Our six yard CWS on average will accommodate a 350 cubic yard pour, approximately 36 mixer trucks and 2 pump trucks. Ramps, allow both the pump & mixer trucks to utilize the same washout.

We also offer crane rated pump pans - see the WashoutPan price list for service and rental pricing.

Established in 2004, we are the industries first and trusted service provider for infrastructure, military, commercial & residential projects.

Our customers include: Kiewit, Sundt, Hensel Phelps, McCarthy, Flatiron, Granite, Balfour Beatty, Coffman, Shea, Skanska and Austin Commercial to name a few.

Compliance with LEED and diversion programs are easy with our digital receipts emailed upon request.

As the preferred service provider, we not only properly handle and recycle the concrete washout material, we properly handle and recycle the caustic, high PH water collected.

Our roll off trucks have a built in vacuum system, allowing us to usually service a washout with a single truck.



American CONCRETE WASHOUTS

1 (800) 788-0355

March 9, 2016
Item 12
Supporting Document No. 036

2015 CONCRETE WASHOUT SERVICE COST

SAN DIEGO, CA

Please provide three (3) working days notice for service requests.

Washout cost are listed by distance and include delivery, a Washout Water Vacuum up to 300 gallons at removal or swap and recycling of the solids. We never charge for mileage, removal, tonnage fees, environmental fees or recycle documentation. Additional Water Vacuums and Same Site Relocates are available. Never line our containers with plastic as they are watertight and will result in landfill charges. We accept concrete washout and clean broken concrete only. We **DO NOT** accept saw cutting or grindings.

Cost by Radius from Mission Valley / San Diego	Within 20 miles	20 to 40 Miles	40 to 60 Miles
Concrete Washout (Ramp or Rampless)	\$475	\$525	\$575
300 Gallon Vacuum at Removal or Swap	\$0	\$0	\$0
Removal / Pull	\$0	\$0	\$0
Daily Rental	\$7	\$7	\$7
Fuel Surcharge (Variable)	8% +/-	8% +/-	8% +/-
Environmental / Mileage / Diversion	\$0	\$0	\$0
Same Day Service Fee	\$175	\$175	\$175
Additional Water Vacuums / Relocates / Canceled Service	\$275	\$325	\$375
RAPIDGate Requirement Surcharge	\$25 Per Service	\$25 Per Service	\$25 Per Service
Trash / Plastic / Saw Cuttings / Dirt / Rebar / Wire Mesh Anything but Concrete (Placed in Bin)	\$75 Per Ton Fine	\$75 Per Ton Fine	\$75 Per Ton Fine

Ramps allow concrete pump trucks the ability to back onto the container capturing their washout. Mixer trucks also use the container by pulling alongside.

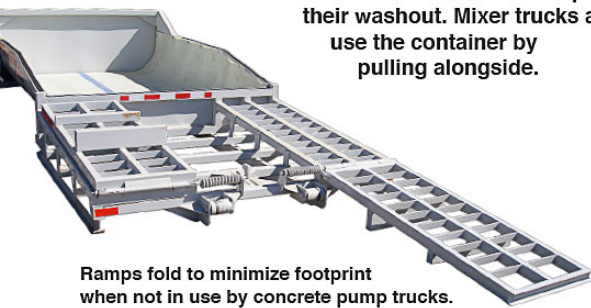

Ramps fold to minimize footprint when not in use by concrete pump trucks.



Rampless models also available.

Ramped concrete washout for both concrete mixer, pump trucks and more.

American CONCRETE WASHOUTS

1 (800) 788-0355

72" x 72" x 14" WASHOUT PAN ONE YARD PAN

SERVICE COST

SAN DIEGO, CA

Please provide three (3) working days notice for service requests.

Washout cost are listed by distance and include delivery, a Washout Water Vacuum up to 300 gallons at removal or swap and recycling of the solids. We never charge for mileage, removal, tonnage fees, environmental fees or recycle documentation. Additional Water Vacuums and Same Site Relocates are available. Never line our containers with plastic as they are watertight and will result in landfill charges. We accept concrete washout and clean broken concrete only. We **DO NOT** accept saw cutting or grindings.

Cost by Radius from Mission Valley / San Diego	Within 20 miles	20 to 40 Miles	40 to 60 Miles
Delivery 72"x72"x14" - Up to three pans for one price	\$275	\$325	\$375
300 Gallon Vacuum at Removal or Swap	\$0	\$0	\$0
Removal or Swap - Up to three pans for one price	\$275	\$325	\$375
Daily Rental Per Pan	\$3	\$3	\$3
Fuel Surcharge	10% +/-	10% +/-	10% +/-
Environmental / Mileage / Diversion	\$0	\$0	\$0
Same Day Service Fee	\$175	\$175	\$175
Additional Water Vacuums / Relocates / Canceled Service	\$275	\$325	\$375
RAPIDGate Requirement Surcharge	\$25 Per Service	\$25 Per Service	\$25 Per Service
Trash / Plastic / Saw Cuttings / Dirt / Rebar / Wire Mesh Anything but Concrete (Placed in Bin)	\$75 Per Ton Fine	\$75 Per Ton Fine	\$75 Per Ton fine
Replacement Value of Lost or Damaged Pan	\$1899 each		



- High strength 1/4" steel floors
- High strength 7 gauge steel walls
- Hand welded with continuous seams
- Five 18,500 lbs. rated lifting/rigging "D" rings
- Load tested at 25,000 lbs. – Maximum weight 12,500 lbs.
- Engineer rated – calculation packets available
- 11" Wide angled enclosed fork pockets, spaced 40" OD to OD and will fit most adjustable lifts
- Tapered interior walls for easy release of materials
- Pans nest inside of each

American CONCRETE WASHOUTS

CONCRETE, PAINT AND DRYWALL WASHOUT SERVICES

1 (800) 788-0355

Please provide three (3) working days notice for service requests.

Our 448 gallon Paint Washout Station is designed for the paint, drywall, tile, and stucco trades. Made from steel construction with two-way forklift channels and work grate for tool washout, our washout system has proven to be the best available technology for construction sites.

Cost by Radius from Mission Valley / San Diego	Within 20 miles	20 to 40 Miles	40 to 60 Miles
448 Gallon Paint / Drywall Washout - Per Trip	\$275	\$325	\$375
Removal / Pull - Per Container	\$275	\$325	\$375
Daily Rental	\$5	\$5	\$5
Fuel Surcharge	10% +/-	10% +/-	10% +/-
Environmental / Mileage / Diversion	\$0	\$0	\$0
Same Day Service Fee	\$175	\$175	\$175
Additional Water Vacuums / Relocates / Canceled Trip	\$275	\$325	\$375
RAPIDGate Requirement Surcharge	\$25 Per Service	\$25 Per Service	\$25 Per Service
Anything but Latex Paint or Drywall Washout (Placed in Bin)	\$75 Per Ton Fine	\$75 Per Ton Fine	\$75 Per Ton Fine



Exhibit No. 29

Staff Cost Summary

March 2015 through September 2015

Staff hours as of September 30, 2015.

STAFF	HOURS	MONTHLY SALARY	Hourly	Hourly total	Benefits	Total
CCLEMENTE	1.75	\$9,899	\$57.11	\$99.94	\$43.19	\$143.13
EBECKER	1.25	\$10,501	\$60.58	\$75.73	\$32.72	\$108.45
FMELBOURN	196.50	\$8,915	\$51.43	\$10,106.72	\$4,367.11	\$14,473.83
JSMITH	1.75	\$12,620	\$72.81	\$127.42	\$55.06	\$182.47
WCHIUI	10.00	\$8,915	\$51.43	\$514.34	\$222.24	\$736.58
JHAAS	1.25	\$11,447	\$66.04	\$82.55	\$35.67	\$118.22
	212.50			TOTAL COSTS		\$15,762.69