

**CALIFORNIA REGIONAL WATER QUALITY CONTROL BOARD  
SAN DIEGO REGION**

2375 Northside Drive, Suite 100, San Diego, CA 92108  
Phone (619) 516-1990 • Fax (619) 516-1994  
<http://www.waterboards.ca.gov/sandiego/>

Clean Water Act Section 401 Water Quality Certification  
and Waste Discharge Requirements  
for Discharge of Dredged and/or Fill Materials

**PROJECT: Poway Mine Site  
Certification Number 12C-079  
WDID: 9000002517**

Reg. Meas. ID: 387643 Place ID: 786930 Party ID: 537140 Person ID: 537142
--

**APPLICANT: Vulcan Materials Company  
500 N. Brand Ave, Suite 500  
Glendale, CA 91203**

**ACTION:**

<input type="checkbox"/> Order for Low Impact Certification	<input type="checkbox"/> Order for Denial of Certification
<input checked="" type="checkbox"/> Order for Technically-conditioned Certification	<input type="checkbox"/> Enrollment in Isolated Waters Order No. 2004-004-DWQ
<input checked="" type="checkbox"/> Enrollment in SWRCB GWDR Order No. 2003-017-DWQ	

**PROJECT DESCRIPTION**

An application dated September 19, 2012 was submitted by Vulcan Materials Company (hereinafter Applicant), for Water Quality Certification pursuant to section 401 of the Clean Water Act (33 U.S.C. § 1341) for the proposed Poway Mine Site Project (Project). The California Regional Water Quality Control Board, San Diego Region (San Diego Water Board) deemed the application to be complete on October 17, 2012. The Applicant proposes to discharge dredged or fill material to waters of the United States and/or State associated with construction activity at the Project site. The Applicant has also applied for a Clean Water Act section 404 permit from the United States Army Corps of Engineers for the Project (USACE File No. SPL-2008-01241-PJB).

The Project is located within the City of Poway, San Diego County, California at 13501 Kirkham Way just north of Beeler Canyon Road and Old Creek Road. The Project center reading is located at latitude 32.927560 and longitude -117.039561. The site includes three parcels encompassing a total of 166 acres. The Applicant has paid all required fees in the amount of \$22,722.00. On September 24, 2012, the San Diego Water Board provided public notice of the Project application pursuant to California Code of Regulations, title 23, section 3858 by posting information describing the Project on the San Diego Water Board's web site and providing a period of twenty-one days for public review and comment. No comments were received.

Consistent with the City of Poway Conditional Use Permit and Reclamation Plan 89-05 (CUP/RP 89-05), the Applicant proposes to impact jurisdictional waters of the United States

and/or State to restore a highly degraded and flood prone section of Beeler Creek (Drainage 1 and 2) and to conduct reclamation activities in the ephemeral drainages to Beeler Creek (Drainages 2 and 3). Implementation of the CUP/RP 89-05 also satisfies the mitigation requirements of the South Poway Specific Plan and the habitat enhancements described in the Poway Subarea Habitat Conservation Plan/Natural Community Conservation Plan (PSHCP). The City of Poway approved CUP/RP 89-05 in 1991.

The CUP/RP requires the construction of a channel in Beeler Creek that can safely carry the flows associated with a 100-year frequency storm event. Beeler Creek (Creek) is located near the Vulcan Materials Company Plant and Beeler Creek Road. This reach contains approximately 1,743 feet of highly disturbed channel. The restoration will remove approximately 920 linear feet (LF) of concrete-lining in the Creek bed and floodplain, including the existing undersized culvert crossing; restore an 823-foot section of disturbed and unlined Creek channel upstream of the existing crossing; and restore a concrete section of channel that runs along the southern edge of the existing silt ponds. This restoration project will also extend an additional 195 feet downstream of the existing disturbed Creek channel in order to properly tie into the downstream portion of the Creek bed. The restoration is required under the CUP/RP and considered separate from the Project mitigation.

The Applicant is proposing to construct a 5.97-acre floodplain that ties into the existing natural Creek channel upstream of the restoration area. A 10-foot wide, 1,733 LF, sinuous low-flow channel will be constructed within the widened floodplain. The floodplain and low-flow Creek channel will be re-vegetated and seeded with native riparian and upland plant species.

In addition to widening the Creek channel, the Applicant also proposes to install a single concrete grade control structure at the downstream end of the restored floodplain. The energy dissipater will extend 10 feet upstream and be constructed of grouted riprap buried below the channel bed. The downstream energy dissipater will extend 27 feet downstream and consist of ungrouted riprap placed into the channel bed. The grade control structure is required to keep water velocities from the peak 100-year frequency storm at or below the established 6 feet per second (fps) threshold and prevent headward erosion of the restored floodplain and sedimentation of the channel downstream. The drop in elevation from the east end of Beeler Creek to the grade control structure is approximately 25 feet.

The grade control structure will double as a secondary emergency crossing (Arizona style) from the Project site to Beeler Canyon as required by the CUP/RP 89-05. The top of the drop structure is approximately 12-feet wide in order to accommodate the emergency crossing. The emergency crossing will only provide access to the site from Beeler Canyon Road in the event of an emergency.

Approximately 37,337 cubic yards (CY) of materials (concrete and native soils) will be excavated from the restoration area to create the widened floodplain. Out of the total material excavated, an estimated 14,500 CY will be used to create the proposed widened floodplain. The remaining 22,887 CY of excess material will be incorporated as fill for the on-site reclamation activities and any remaining concrete debris will be crushed on-site for recycling or hauled off-site for disposal in accordance with local, State, and Federal regulations. Approximately 150 CY of concrete and 1,593 tons quarter-ton riprap will be used to construct the grade control structure. Approximately 6 CY of concrete and 3.5 CY of quarter-ton riprap will be placed in jurisdictional areas.

The Project may also include the building of light industrial pads at top of Drainage 2 and 3 along Kirkham Way. Recontouring and grading for five industrial pads is included as part of the Project, however the final decision to move forward with this part of the Project will be decided at a later date. Construction of buildings or other permanent structures on the industrial pads is not part of this Project.

### **Site Reclamation**

The Project proposed in 2012 included four phases of mining of 127 acres of land over 15 to 20 years and had 0.128 acres of permanent impacts. The third and fourth phases of mining would have removed a large portion of Drainage 3. The current Project has eliminated all phases of mining and is now only includes the required restoration work in Beeler Creek and the future industrial pads. The revised Project avoids approximately 92% of Drainage 3 with the only potential impacts being those from the industrial pads. Impacts to Drainage 2 remain unchanged from the 2012 Project and are limited to the upper reach where one of the industrial pads is located.

Reclamation will focus on restoring the previously mined and developed areas of the southwestern quarter of the site with native vegetation. Impacts to waters of the United States and/or State during Site Reclamation will occur through the construction of the light industrial building pads.

The final landform of the reclaimed area will be natural-looking, engineered slopes that transitions into the undisturbed natural area to the east of the previously mined area. The Reclaimed Project site, except for the 15-acres of light industrial pads, if built, will be planted with the appropriate native plant species to restore the native coastal sage scrub and native grassland communities. The City of Poway will rezone the restored area as Natural Open Space as required by the PSHCP once reclamation activities are complete.

### **Impervious Surfaces**

The Project will add approximately 0.27 acres of new impervious surface for the Creek crossing and extension of the access road from the existing driveway to the creek crossing. The Project will remove 3.38 acres of existing impervious surface. The previously mined area and existing plant site will be reclaimed and revegetated with native plant species. If the industrial pads are built, a total of five temporary detention basins will also be used within the undeveloped industrial pads to handle storm water until they are developed at a later date. These BMPs will be designed, constructed, and maintained to meet City of Poway's Low Impact Development (LID) Capture Volume and hydromodification treatment requirements.

### **Project Impacts**

If the Project is fully implemented, the Project construction will permanently impact 0.012 acres in Beeler Creek and up to 0.064 acres in Drainage 2 and 3 for the industrial pad construction for a maximum of 0.076 acres (965 LF) and temporarily 0.31 acres (1,668 LF) impact of waters of the United States and/or State.

Impacts to Beeler Creek will occur when the Applicant restores the highly disturbed "Central Reach" (approximately 1,938 LF) as described previously. The proposed restoration activity will permanently impact 0.008 acre (69 LF) of ephemeral streambed and 0.004 acre of freshwater wetland. The restoration provides an overall net increase of 0.27 acres of

streambed habitat. Temporary impacts from the restoration Project include 0.26 acre (1,668 LF) of ephemeral streambed and 0.049 acre of wetland habitat.

### **Compensatory Mitigation**

The Applicant reports that compensatory mitigation for the permanent loss of 0.012 acre of jurisdictional waters related to the restoration Project will be achieved through the purchase of a minimum of 0.036 establishment and/or re-establishment mitigation bank credits from the San Luis Rey Mitigation Bank (Bank) in advance of Project construction to achieve a minimum compensation ratio of 3:1 (area mitigated:area impacted). If recontouring and grading for five industrial pads is initiated, the Applicant will provide additional establishment (creation)/re-establishment mitigation credits for the permanent loss of up to 0.064 acre of jurisdictional waters at minimum compensation ratio of 3:1 (area mitigated:area impacted). The Bank is on 55.84 acres of land located in the San Luis Rey River flood plain in the lower San Luis hydrologic sub-area (HSA 903.1) in the City of Oceanside, San Diego County, California. Mitigation credit parcels, purchased from the Bank by the Applicant to satisfy compensatory mitigation requirements, are required to be protected, monitored and maintained in perpetuity by the Bank pursuant to a federal and State approved bank enabling instrument and a recorded conservation easement.

The compensatory mitigation for the restoration of Beeler Creek will be provided prior to the initiation of construction of this Project. Likewise, compensatory mitigation of the construction of the industrial pads, in the form of mitigation credits, will be purchased at a minimum ratio of 3:1 for not more than 0.032 acres of permanent impacts, prior to the initiation of their construction, if undertaken. If the construction of the industrial pads is found to be infeasible and there are no impacts to the headwaters of Drainages 2 and 3, no mitigation will be required.

The restoration and reclamation work in Beeler Creek is a requirement of the Applicant's CUP/RP 89-05 and is not considered in determining required compensatory mitigation under this Certification. The Project will provide 0.45 acres and 1,993 linear feet of re-established stream. The Project is within the City of Poway's South Poway Corner Stone Area and the restoration will be protected as Natural Open Space under their Habitat Conservation Plan (HCP) and Natural Community Conservation Plan (NCCP). Other restoration work required as part of CUP/RP 89-05 includes upland restoration of the previously mined areas and the facility building and processing plant areas. Upland restoration is estimated to be 60 acres.

The Project application includes a description of the design objective, operation, and degree of treatment expected to be attained from equipment, facilities, or activities (including construction and post-construction BMPs) to treat waste and reduce runoff or other effluents, which may be discharged. Compliance with the Certification conditions will help ensure that construction and post-construction discharges from the Project will not cause on-site or off-site downstream erosion, damage to downstream properties, or otherwise damage stream habitats in violation of water quality standards in the *Water Quality Control Plan for the San Diego Basin (9)* (Basin Plan).

Wildlands, a habitat development and land management company, is the Bank Sponsor and is responsible for Bank design, entitlement, construction and long-term operations and management. Detailed written specifications and descriptions of the methods being used to monitor the Bank through the initial 5-year success period including, but not limited to, the

geographic boundaries of the Bank, timing, sequence, monitoring, maintenance, and ecological success performance standards are described in the *San Luis Rey Mitigation Bank Development Plan (Bank Development Plan) dated November 2012 for the San Luis Rey Mitigation Bank*. The Bank Development Plan was previously accepted by the San Diego Water Board under the terms and conditions of Water Quality Certification No. R9-2013-0050, issued by the San Diego Water Board for the development and maintenance of the Bank on April 13, 2014.

In addition, the Applicant has prepared and submitted the *Restoration Plan for Vulcan Materials Company's Poway Mine, (Restoration Plan)*, dated March 2017 to fulfill mitigation requirements required by federal and state agencies for the Project including the San Diego Water Board. Acceptance of the Restoration Plan and the Bank Development Plan applies only to the Project described in this Certification and must not be construed as approval for other current or future projects that are planning to use additional acreage at the site for mitigation. The Restoration Plan and the Bank Development Plan are incorporated in this Certification by this reference as if fully set forth herein. The Restoration Plan and the Bank Development Plan provide for implementation of compensatory mitigation which offsets adverse water quality impacts attributed to the Project in a manner that protects and restores the abundance, types and conditions of aquatic resources and supports their beneficial uses. Implementation of the Restoration Plan and the Bank Development Plan will reduce significant environmental impacts to aquatic resources within the San Diego Water Board's purview to a less than significant level. Based on all of these considerations implementation of the Restoration Plan and the Bank Development Plan will adequately compensate for the loss of beneficial uses and habitat within waters of the United States and/or State attributable to the Project.

Additional Project details are provided in Attachments 1 through 5 of this Certification.

## TABLE OF CONTENTS

I.	STANDARD CONDITIONS.....	7
II.	GENERAL CONDITIONS .....	7
III.	CONSTRUCTION BEST MANAGEMENT PRACTICES .....	10
IV.	POST-CONSTRUCTION BEST MANAGEMENT PRACTICES .....	12
V.	PROJECT IMPACTS AND COMPENSATORY MITIGATION .....	13
VI.	MONITORING AND REPORTING REQUIREMENTS .....	16
VII.	NOTIFICATION REQUIREMENTS .....	19
VIII.	CALIFORNIA ENVIRONMENTAL QUALITY ACT COMPLIANCE .....	21
IX.	SAN DIEGO WATER BOARD CONTACT PERSON .....	22
X.	WATER QUALITY CERTIFICATION .....	22

### Attachments:

1. Definitions
2. Project Location Maps
3. Project Site Plans
4. Mitigation Figures
5. CEQA Mitigation Monitoring and Reporting Program

## I. STANDARD CONDITIONS

Pursuant to section 3860 of title 23 of the California Code of Regulations, the following three standard conditions apply to all water quality certification actions:

- A. This Certification action is subject to modification or revocation upon administrative or judicial review, including review and amendment pursuant to section 13330 of the Water Code and chapter 28, article 6 (commencing with title 23, section 3867), of the California Code of Regulations.
- B. This Certification action is not intended and shall not be construed to apply to any discharge from any activity involving a hydroelectric facility and requiring a Federal Energy Regulatory Commission (FERC) license or an amendment to a FERC license unless the pertinent Certification application was filed pursuant to California Code of Regulations title 23, section 3855 subdivision (b), and that application specifically identified that a FERC license or amendment to a FERC license for a hydroelectric facility was being sought.
- C. This Certification action is conditioned upon total payment of any fee required under title 23, chapter 28 (commencing with section 3830) of California Code of Regulations and owed by the applicant.

## II. GENERAL CONDITIONS

- A. **Term of Certification.** Water Quality Certification No. 12C-079 (Certification) shall expire upon a) the expiration or retraction of the Clean Water Act section 404 (33 USC Title 33, section 1344) permit issued by the U.S. Army Corps of Engineers for this Project, or b) ten (10) years from the date of issuance of this Certification, whichever occurs first.
- B. **Duty to Comply.** The Applicant must comply with all conditions and requirements of this Certification. Any Certification noncompliance constitutes a violation of the Water Code and is grounds for enforcement action or Certification termination, revocation and reissuance, or modification.
- C. **General Waste Discharge Requirements.** The requirements of this Certification are enforceable through Water Quality Order No. 2003-0017-DWQ, *Statewide General Waste Discharge Requirements for Discharges of Dredged or Fill Material that have Received State Water Quality Certification* (Water Quality Order No. 2003-0017-DWQ). This provision shall apply irrespective of whether a) the federal permit for which the Certification was obtained is subsequently retracted or is expired, or b) the Certification is expired. Water Quality Order No. 2003-0017-DWQ is accessible at:

[http://www.waterboards.ca.gov/water\\_issues/programs/cwa401/docs/generalorders/gowdr401regulated\\_projects.pdf](http://www.waterboards.ca.gov/water_issues/programs/cwa401/docs/generalorders/gowdr401regulated_projects.pdf).

- D. **Project Conformance with Application.** All water quality protection measures and BMPs described in the application and supplemental information for water quality certification are incorporated by reference into this Certification as if fully stated herein.

Notwithstanding any more specific conditions in this Certification, the Applicant shall construct, implement and comply with all water quality protection measures and BMPs described in the application and supplemental information. The conditions within this Certification shall supersede conflicting provisions within the application and supplemental information submitted as part of this Certification action.

- E. Project Conformance with Water Quality Control Plans or Policies.** Notwithstanding any more specific conditions in this Certification, the Project shall be constructed in a manner consistent with the Basin Plan and any other applicable water quality control plans or policies adopted or approved pursuant to the Porter Cologne Water Quality Act (Division 7, commencing with Water Code Section 13000) or section 303 of the Clean Water Act (33 USC section 1313). The Basin Plan is accessible at:

[http://www.waterboards.ca.gov/sandiego/water\\_issues/programs/basin\\_plan/index.shtml](http://www.waterboards.ca.gov/sandiego/water_issues/programs/basin_plan/index.shtml)

- F. Project Modification.** The Applicant must submit any changes to the Project, including Project operation, which would have a significant or material effect on the findings, conclusions, or conditions of this Certification, to the San Diego Water Board for prior review and written approval. If the San Diego Water Board is not notified of a significant change to the Project, it will be considered a violation of this Certification.

- G. Certification Distribution Posting.** During Project construction, the Applicant must maintain a copy of this Certification at the Project site. This Certification must be available at all times to site personnel and agencies. A copy of this Certification shall also be provided to any contractor or subcontractor performing construction work, and the copy shall remain in their possession at the Project site.

- H. Inspection and Entry.** The Applicant must allow the San Diego Water Board or the State Water Resources Control Board, and/or their authorized representative(s) (including an authorized contractor acting as their representative), upon the presentation of credentials and other documents as may be required under law, to:

1. Enter upon the Project or Compensatory Mitigation site(s) premises where a regulated facility or activity is located or conducted, or where records must be kept under the conditions of this Certification;
2. Have access to and copy, at reasonable times, any records that must be kept under the conditions of this Certification;
3. Inspect, at reasonable times, any facilities, equipment (including monitoring and control equipment), practices, or operations regulated or required under this Certification; and
4. Sample or monitor, at reasonable times, for the purposes of assuring Certification compliance, or as otherwise authorized by the Clean Water Act or Water Code, any substances or parameters at any location.

- I. Enforcement Notification.** In the event of any violation or threatened violation of the conditions of this Certification, the violation or threatened violation shall be subject to



any remedies, penalties, process or sanctions as provided for under State law. For purposes of section 401(d) of the Clean Water Act, the applicability of any State law authorizing remedies, penalties, process or sanctions for the violation or threatened violation constitutes a limitation necessary to assure compliance with the water quality standards and other pertinent requirements incorporated into this Certification.

- J. Certification Actions.** This Certification may be modified, revoked and reissued, or terminated for cause including but not limited to the following:
1. Violation of any term or condition of this Certification;
  2. Monitoring results indicate that continued Project activities could violate water quality objectives or impair the beneficial uses of Beeler Creek or its tributaries;
  3. Obtaining this Certification by misrepresentation or failure to disclose fully all relevant facts;
  4. A change in any condition that requires either a temporary or permanent reduction or elimination of the authorized discharge; and
  5. Incorporation of any new or revised water quality standards and implementation plans adopted or approved pursuant to the Porter-Cologne Water Quality Control Act or section 303 of the Clean Water Act.
- The filing of a request by the Applicant for modification, revocation and reissuance, or termination, or a notification of planned changes or anticipated noncompliance does not stay any Certification condition.
- K. Duty to Provide Information.** The Applicant shall furnish to the San Diego Water Board, within a reasonable time, any information which the San Diego Water Board may request to determine whether cause exists for modifying, revoking and reissuing, or terminating this Certification or to determine compliance with this Certification.
- L. Property Rights.** This Certification does not convey any property rights of any sort, or any exclusive privilege.
- M. Petitions.** Any person aggrieved by this action of the San Diego Water Board may petition the State Water Resources Control Board (State Water Board) to review the action in accordance with the California Code of Regulations, title 23, sections 3867 and following. The State Water Board must receive the petition by 5:00 p.m., 30 days after the date of this Certification. Copies of the law and regulations applicable to filing petitions may be found on the Internet at:  
[http://www.waterboards.ca.gov/public\\_notices/petitions/water\\_quality](http://www.waterboards.ca.gov/public_notices/petitions/water_quality) or will be provided upon request.

### III. CONSTRUCTION BEST MANAGEMENT PRACTICES

- A. **Approvals to Commence Construction.** The Applicant shall not commence Project construction until all necessary federal, State, and local approvals are obtained.
- B. **Personnel Education.** Prior to the start of the Project, and annually thereafter, the Applicant must educate all personnel on the requirements in this Certification, pollution prevention measures, spill response measures, and BMP implementation and maintenance measures.
- C. **Spill Containment Materials.** The Applicant must, at all times, maintain appropriate types and sufficient quantities of materials on-site to contain any spill or inadvertent release of materials that may cause a condition of pollution or nuisance if the materials reach waters of the United States and/or State.
- D. **General Construction Storm Water Permit.** Prior to start of Project construction, the Applicant must, as applicable, obtain coverage under, and comply with, the requirements of State Water Resources Control Board Water Quality Order No. 2009-0009-DWQ, the *General Permit for Storm Water Discharges Associated with Construction and Land Disturbance Activity*, (General Construction Storm Water Permit) and any reissuance. If Project construction activities do not require coverage under the General Construction Storm Water Permit, the Applicant must develop and implement a runoff management plan (or equivalent construction BMP plan) to prevent the discharge of sediment and other pollutants during construction activities.
- E. **Waste Management.** The Applicant must properly manage, store, treat, and dispose of wastes in accordance with applicable federal, state, and local laws and regulations. Waste management shall be implemented to avoid or minimize exposure of wastes to precipitation or storm water runoff. The storage, handling, treatment, or disposal of waste shall not create conditions of pollution, contamination or nuisance as defined in Water Code section 13050. Upon Project completion, all Project generated debris, building materials, excess material, waste, and trash shall be removed from the Project site(s) for disposal at an authorized landfill or other disposal site in compliance with federal, state and local laws and regulations.
- F. **Waste Management.** Except for a discharge permitted under this Certification, the dumping, deposition, or discharge of trash, rubbish, unset cement or asphalt, concrete, grout, damaged concrete or asphalt, concrete or asphalt spoils, wash water, organic or earthen material, steel, sawdust or other construction debris waste from Project activities directly into waters of the United States and or State, or adjacent to such waters in any manner which may permit its being transported into the waters, is prohibited.
- G. **Downstream Erosion.** Discharges of concentrated flow during construction or after Project completion must not cause downstream erosion or damage to properties or stream habitat.
- H. **Construction Equipment.** All equipment must be washed prior to transport to the Project site and must be free of sediment, debris, and foreign matter. All equipment

used in direct contact with surface water shall be steam cleaned prior to use. All equipment using gas, oil, hydraulic fluid, or other petroleum products shall be inspected for leaks prior to use and shall be monitored for leakage. Stationary equipment (e.g., motors, pumps, generator, etc.) shall be positioned over drip pans or other types of containment.

- I. **Process Water.** Water containing mud, silt, or other pollutants from equipment washing or other activities, must not be discharged to waters of the United States and/or State or placed in locations that may be subjected to storm water runoff flows. Pollutants discharged to areas within a stream diversion must be removed at the end of each work day or sooner if rain is predicted.
- J. **Surface Water Diversion.** All surface waters, including ponded waters, must be diverted away from areas of active grading, construction, excavation, vegetation removal, and/or any other activity which may result in a discharge to the receiving water. Diversion activities must not result in the degradation of beneficial uses or exceedance of the receiving water quality objectives. Any temporary dam or other artificial obstruction constructed must only be built from materials such as clean gravel which will cause little or no siltation. Normal flows must be restored to the affected stream immediately upon completion of work at that location.
- K. **Re-vegetation and Stabilization.** All areas that have 14 or more days of inactivity must be stabilized within 14 days of the last activity. The Applicant shall implement and maintain BMPs to prevent erosion of the rough graded areas. After completion of grading, all areas must be re-vegetated with native species appropriate for the area. The re-vegetation palette must not contain any plants listed on the California Invasive Plant Council Invasive Plant Inventory, which can be accessed at <http://www.cal-ipc.org/ip/inventory/>.
- L. **Hazardous Materials.** Except as authorized by this Certification, substances hazardous to aquatic life including, but not limited to, petroleum products, unused cement/concrete, asphalt, and coating materials, must be prevented from contaminating the soil and/or entering waters of the United States and/or State. BMPs must be implemented to prevent such discharges during each Project activity involving hazardous materials.
- M. **Vegetation Removal.** Removal of vegetation must occur by hand, mechanically, or through application of United States Environmental Protection Agency (USEPA) approved herbicides deployed using applicable BMPs to minimize adverse effects to beneficial uses of waters of the United States and/or State. Discharges related to the application of aquatic pesticides within waters of the United States must be done in compliance with State Water Resources Control Board Water Quality Order No. 2004-0009-DWQ, the *Statewide General National Pollution Discharge Elimination System Permit for the Discharge of Aquatic Weed Control in Waters of the United States*, and any subsequent reissuance as applicable.
- N. **Limits of Disturbance.** The Applicant shall clearly define the limits of Project disturbance to waters of the United States and/or State using highly visible markers

such as flag markers, construction fencing, or silt barriers prior to commencement of Project construction activities within those areas.

- O. **On-site Qualified Biologist.** The Applicant shall designate an on-site qualified biologist to monitor Project construction activities within or adjacent to waters of the United States and/or State to ensure compliance with the Certification requirements. The biologist shall be given the authority to stop all work on-site if a violation of this Certification occurs or has the potential to occur. Records and field notes of the biologist's activities shall be kept on-site and made available for review upon request by the San Diego Water Board.
- P. **Beneficial Use Protection.** The Applicant must take all necessary measures to protect the beneficial uses of waters of Beeler Creek. This Certification requires compliance with all applicable requirements of the Basin Plan. If at any time, an unauthorized discharge to surface waters (including rivers or streams) occurs or monitoring indicates that the Project is violating, or threatens to violate, water quality objectives, the associated Project activities shall cease immediately and the San Diego Water Board shall be notified in accordance with Notification Requirement VII.A of this Certification. Associated Project activities may not resume without approval from the San Diego Water Board.
- Q. **Groundwater Dewatering.** If groundwater dewatering is required for the Project, the Applicants shall enroll in and comply with the requirements of San Diego Water Board Order No. R9-2015-0013, NPDES No. CAG919002, *General Waste Discharge Requirements For Groundwater Extraction Waste Discharges in the San Diego Region* or its successor permit.

#### IV. POST-CONSTRUCTION BEST MANAGEMENT PRACTICES

- A. **Post-Construction Discharges.** The Applicant shall not allow post-construction discharges from the Project site to cause or contribute to on-site or off-site erosion or damage to properties or stream habitats.
- B. **Storm Drain Inlets.** All storm drain inlet structures within the Project boundaries must be stamped or stenciled (or equivalent) with appropriate language prohibiting non-storm water discharges.
- C. **Post-Construction BMP Design.** The Project must be designed to comply with the requirements for priority development projects in section E.3 of the Regional MS4 Permit Order R9-2013-0001, *National Pollutant Discharge Elimination Systems Permit and Waste Discharge Requirements for Discharges of Urban Runoff from the MS4s Draining the Watersheds within the San Diego Region* (Regional MS4 Permit) as well as the most current Standard Storm Water Mitigation and Hydromodification Plans for the City of Poway. Where conflict exists between the referenced documents the most stringent requirements shall apply. The Applicant must submit a Storm Water Pollution Prevention Plan (SWPPP) prior to initiation of construction for the industrial pads.
- D. **Post-Construction BMP Implementation.** All post-construction BMPs must be constructed, functional, and implemented prior to completion of Project construction,

occupancy, and/or planned use, and maintained in perpetuity. The post construction BMPs must be approved by City of Poway.

**E. Post-Construction BMP Maintenance.** The post construction BMPs must be designed, constructed, and maintained in accordance with the most recent California Storm Water Quality Association (CASQA)<sup>1</sup> guidance. The Applicant shall:

1. No less than two times per year, assess the performance of the BMPs to ensure protection of the receiving waters and identify any necessary corrective measures;
2. Perform inspections of BMPs, at the beginning of the wet season no later than October 1 and the end of the wet season no later than April 1, for standing water, slope stability, sediment accumulation, trash and debris, and presence of burrows;
3. Regularly perform preventative maintenance of BMPs, including removal of accumulated trash and debris, as needed to ensure proper functioning of the BMPs;
4. Identify and promptly repair damage to BMPs; and
5. Maintain a log documenting all BMP inspections and maintenance activities. The log shall be made available to the San Diego Water Board upon request.

## **V. PROJECT IMPACTS AND COMPENSATORY MITIGATION**

**A. Project Impact Avoidance and Minimization.** The Project must avoid and minimize adverse impacts to waters of the United States and/or State to the maximum extent practicable. Applicant has avoided and minimized impacts by eliminating 15 to 20 years of phased sand mining (Phases 1-4) from the original Project description. Sand mining in Phases 3 and 4 would have permanently impacted Drainage 3.

**B. Project Impacts and Compensatory Mitigation.** Unavoidable Project impacts to Beeler Creek and its unnamed tributaries within the Penasquitos Watershed must not exceed the type and magnitude of impacts described in the table below. At a minimum, compensatory mitigation required to offset unavoidable temporary and permanent Project impacts to waters of the United States and/or State must be achieved as described in the table below:

---

<sup>1</sup> California Storm Water Quality Association (*California Storm Water BMP Handbook, New Development and Redevelopment 2003*), available on-line at: <http://www.cabmphandbooks.org/> [Accessed on January 15, 2012]

	Impacts (acres)	Impacts (linear ft.)	Mitigation for Impacts (acres)	Mitigation Ratio (area mitigated : area impacted)	Mitigation for Impacts (linear ft.)	Mitigation Ratio (linear feet mitigated : linear feet impacted)
<b>Permanent Impacts</b>						
Beeler Creek-Grade Control Structure	0.012	69	0.036 Establishment/Re-Establishment credits <sup>1</sup>	3:1	NA <sup>2</sup>	NA <sup>2</sup>
Stream Channel – Drainage 2 Non-Wetland <sup>3</sup>	0.022	191	Up to 0.066 Establishment/Re-Establishment credits <sup>1</sup>	3:1	NA <sup>2</sup>	NA <sup>2</sup>
Stream Channel – Drainage 3 Non Wetland <sup>3</sup>	0.032	705	Up to 0.096 Establishment/Re-Establishment credits <sup>1</sup>	3:1	NA <sup>2</sup>	NA <sup>2</sup>
Stream Channel – Drainage 3 Wetland <sup>3</sup>	0.01		Up to 0.03 Establishment/Re-Establishment credits <sup>1</sup>	3:1	NA <sup>2</sup>	NA <sup>2</sup>
<b>Temporary Impacts<sup>4</sup></b>						
Beeler Creek-Non Wetland	0.26 <sup>5,6</sup>	1,668 <sup>5,6</sup>				
Beeler Creek-Wetland	0.049 <sup>5,6</sup>					

1. Project mitigation establishment/re-establishment credits purchased from the San Luis Rey Mitigation Bank, Oceanside, CA.
2. Compensatory mitigation is being provided in a contiguous area at the Mitigation Bank (approximately 55.8 acres) therefore, compensatory mitigation for linear feet is not being calculated on a project by project basis.
3. Construction of the industrial pads may occur at a later date. Amount of credits required as mitigation dependent on the number of pads constructed.
4. All areas of temporary impacts must be restored to pre-project contours and re-vegetated with native species.
5. Temporary impacts from the Beeler Creek restoration. The restoration work is a condition of the Project's permit from Poway and not considered mitigation.
6. Restoration work provides a net increase of 0.27 of streambed habitat in addition to the required mitigation credits.

**C. Mitigation Credits.** Prior to the start of construction, the Applicant must provide documentation to the San Diego Water Board verifying the purchase of establishment, and/or re-establishment credits from the San Luis Rey Mitigation Bank as outlined in the above mitigation table.

The use of an alternative mitigation bank to provide required compensatory mitigation must be approved by the San Diego Water Board before the credits are secured and is subject to the following conditions:

1. The Applicant must identify the USACE approved mitigation bank and submit documentation demonstrating that:
  - a. The permitted Project impacts are located within the service area of the mitigation bank; and

- b. The mitigation bank has the appropriate number and resource type of credits available.
2. If San Diego Water Board approval of the mitigation bank is obtained, the Applicant must provide documentation verifying that the appropriate number and resource type of credits have been secured from the mitigation bank prior to the start of construction.
- D. **Compensatory Mitigation Plan Implementation.** The Applicant must fully and completely implement the Mitigation Plan; any deviations from, or revisions to, the Mitigation Plan must be pre-approved by the San Diego Water Board.
- E. **Performance Standards.** Compensatory mitigation required under this Certification shall be considered achieved once the Applicant has provided documentation to the San Diego Water Board that the required mitigation credits were purchased from the approved Bank. The Bank is responsible for meeting the ecological success performance standards contained in the Bank Development Plan (Section G.2, Monitoring and Success Criteria) to the satisfaction of the San Diego Water Board as approved in Water Quality Certification No. R9-2013-0050. Beeler Creek restoration success criteria are described in the Restoration Plan (Section 8, Table 11).
- F. **Compensatory Mitigation Site Design.** The compensatory mitigation site(s) shall be designed to be self-sustaining once performance standards have been achieved. This includes minimization of active engineering features (e.g., pumps) and appropriate siting to ensure that natural hydrology and landscape context support long-term sustainability in conformance with the following conditions:
1. Most of the channels through the mitigation sites shall be characterized by equilibrium conditions, with no evidence of severe aggradation or degradation;
  2. As viewed along cross-sections, the channel and buffer area(s) shall have a variety of slopes, or elevations, that are characterized by different moisture gradients. Each sub-slope shall contain physical patch types or features that contribute to irregularity in height, edges, or surface and to complex topography overall; and
  3. The mitigation sites shall have a well-developed plant community characterized by a high degree of horizontal and vertical interspersion among plant zones and layers.
- G. **Temporary Project Impact Areas.** The Applicant must restore all areas of temporary impacts and all other areas of temporary disturbance which could result in a discharge or a threatened discharge of pollutants to waters of the United States and/or State. Restoration must include grading of disturbed areas to pre-project contours and re-vegetation with native species. The Applicant must implement all necessary BMPs to control erosion and runoff from areas associated with the Project.
- H. **Long-Term Management and Maintenance.** The compensatory mitigation site(s), must be managed, protected, and maintained, in perpetuity, in conformance with the approved Bank Enabling Instrument and the final ecological success performance standards identified in the Bank Development Plan. The aquatic habitats, riparian

areas, buffers and uplands that comprise the mitigation site(s) must be protected in perpetuity from land-use and maintenance activities that may threaten water quality or beneficial uses within the mitigation area(s) in a manner consistent with the following requirements:

1. Any maintenance activities on the mitigation site(s) that do not contribute to the success of the mitigation site(s) and enhancement of beneficial uses and ecological functions and services are prohibited;
2. Maintenance activities must be limited to the removal of trash and debris, removal of exotic plant species, replacement of dead native plant species, and remedial measures deemed necessary for the success of the compensatory mitigation project;
3. The Mitigation site(s) must be maintained, in perpetuity, free of perennial exotic plant species including, but not limited to, pampas grass, giant reed, tamarisk, sweet fennel, tree tobacco, castor bean, and pepper tree. Annual exotic plant species must not occupy more than 5 percent of the mitigation site(s); and
4. If at any time a catastrophic natural event (e.g., fire, flood) causes damage(s) to the mitigation site(s) or other deficiencies in the compensatory mitigation project, the Applicant must take prompt and appropriate action to repair the damage(s) including replanting the affected area(s) and address any other deficiencies. The San Diego Water Board may require additional monitoring by the Applicant to assess how the compensatory mitigation site(s) or project is responding to a catastrophic natural event.

## VI. MONITORING AND REPORTING REQUIREMENTS

- A. **Representative Monitoring.** Samples and measurements taken for the purpose of monitoring under this Certification shall be representative of the monitored activity.
- B. **Monitoring Reports.** Monitoring results shall be reported to the San Diego Water Board at the intervals specified in section VI of this Certification.
- C. **Monitoring and Reporting Revisions.** The San Diego Water Board may make revisions to the monitoring program at any time during the term of this Certification and may reduce or increase the number of parameters to be monitored, locations monitored, the frequency of monitoring, or the number and size of samples collected.
- D. **Records of Monitoring Information.** Records of monitoring information shall include:
  1. The date, exact place, and time of sampling or measurements;
  2. The individual(s) who performed the sampling or measurements;
  3. The date(s) analyses were performed;
  4. The individual(s) who performed the analyses;



5. The analytical techniques or methods used; and
  6. The results of such analyses.
- E. **Geographic Information System Data.** The Applicant must submit Geographic Information System (GIS) shape files of the Project impact sites within 30 days of the start of project construction and GIS shape files of the Project mitigation sites within 30 days of mitigation installation. All impact and mitigation site shape files must be polygons. Two GPS readings (points) must be taken on each line of the polygon and the polygon must have a minimum of 10 points. GIS metadata must also be submitted.
- F. **Annual Project Progress Reports.** The Applicant must submit annual Project progress reports describing status of BMP implementation and compliance with all requirements of this Certification to the San Diego Water Board prior to **March 1** of each year following the issuance of this Certification, until the Project has reached completion. The Annual Project Progress Reports must contain monitoring information sufficient to demonstrate how the project is progressing towards accomplishing its objectives and meeting its performance standards. Annual Project Progress Reports must be submitted even if Project construction has not begun. The monitoring period for each Annual Project Progress Report shall be January 1<sup>st</sup> through December 31<sup>st</sup> of each year. Annual Project Progress Reports must include, at a minimum, the following:
1. **Project Status and Compliance Reporting.** The Annual Project Progress Report must include the following Project status and compliance information:
    - a. The names, qualifications, and affiliations of the persons contributing to the report;
    - b. The status, progress, and anticipated schedule for completion of Project construction activities including the installation and operational status of best management practices project features for erosion and storm water quality treatment;
    - c. A description of Project construction delays encountered or anticipated that may affect the schedule for construction completion; and
    - d. A description of each incident of noncompliance during the annual monitoring period and its cause, the period of the noncompliance including exact dates and times, and if the noncompliance has not been corrected, the anticipated time it is expected to continue; and the steps taken or planned to reduce, eliminate, and prevent reoccurrence of the noncompliance.
- G. **Final Project Completion Report.** The Applicant must submit a Final Project Completion Report to the San Diego Water Board **within 30 days of completion of the Project**. The final report must include the following information:
1. Date of construction initiation;

2. Date of construction completion;
3. BMP installation and operational status for the Project;
4. As-built drawings of the Project, no bigger than 11"X17"; and
5. Photo documentation of implemented post-construction BMPs and all areas of permanent and temporary impacts, prior to and after project construction. Photo documentation must be conducted in accordance with guidelines posted at [http://www.waterboards.ca.gov/sandiego/water\\_issues/programs/401\\_certification/docs/401c/401PhotoDocRB9V713.pdf](http://www.waterboards.ca.gov/sandiego/water_issues/programs/401_certification/docs/401c/401PhotoDocRB9V713.pdf). In addition, photo documentation must include Global Positioning System (GPS) coordinates for each of the photo points referenced

H. **Reporting Authority.** The submittal of information required under this Certification, or in response to a suspected violation of any condition of this Certification, is required pursuant to Water Code section 13267 and 13383. Civil liability may be administratively imposed by the San Diego Water Board for failure to submit information pursuant to Water Code sections 13268 or 13385.

I. **Electronic Document Submittal.** The Applicant must submit all reports and information required under this Certification in electronic format via e-mail to [SanDiego@waterboards.ca.gov](mailto:SanDiego@waterboards.ca.gov). Documents over 50 megabytes will not be accepted via e-mail and must be placed on a disc and delivered to:

California Regional Water Quality Control Board  
San Diego Region  
Attn: 401 Certification No. 12C-079:786930:amonji  
2375 Northside Drive, Suite 100  
San Diego, California 92108

Each electronic document must be submitted as a single file, in Portable Document Format (PDF), and converted to text searchable format using Optical Character Recognition (OCR). All electronic documents must include scanned copies of all signature pages; electronic signatures will not be accepted. Electronic documents submitted to the San Diego Water Board must include the following identification numbers in the header or subject line: Certification No. 12C-079:786930:amonji.

J. **Document Signatory Requirements.** All applications, reports, or information submitted to the San Diego Water Board must be signed as follows:

1. For a corporation, by a responsible corporate officer of at least the level of vice president.
2. For a partnership or sole proprietorship, by a general partner or proprietor, respectively.
3. For a municipality, or a state, federal, or other public agency, by either a principal executive officer or ranking elected official.

4. A duly authorized representative may sign applications, reports, or information if:
  - a. The authorization is made in writing by a person described above.
  - b. The authorization specifies either an individual or position having responsibility for the overall operation of the regulated activity.
  - c. The written authorization is submitted to the San Diego Water Board Executive Officer.

If such authorization is no longer accurate because a different individual or position has responsibility for the overall operation of the Project, a new authorization satisfying the above requirements must be submitted to the San Diego Water Board prior to or together with any reports, information, or applications, to be signed by an authorized representative.

- K. **Document Certification Requirements.** All applications, reports, or information submitted to the San Diego Water Board must be certified as follows:

*"I certify under penalty of law that I have personally examined and am familiar with the information submitted in this document and all attachments and that, based on my inquiry of those individuals immediately responsible for obtaining the information, I believe that the information is true, accurate, and complete. I am aware that there are significant penalties for submitting false information, including the possibility of fine and imprisonment."*

## VII. NOTIFICATION REQUIREMENTS

- A. **Twenty Four Hour Non-Compliance Reporting.** The Applicant shall report any noncompliance which may endanger health or the environment. Any such information shall be provided orally to the San Diego Water Board within **24 hours** from the time the Applicant becomes aware of the circumstances. A written submission shall also be provided within five days of the time the Applicant becomes aware of the circumstances. The written submission shall contain a description of the noncompliance and its cause; the period of noncompliance, including exact dates and times, and if the noncompliance has not been corrected; the anticipated time it is expected to continue; and steps taken or planned to reduce, eliminate, and prevent recurrence of the noncompliance. The San Diego Water Board, or an authorized representative, may waive the written report on a case-by-case basis if the oral report has been received within 24 hours.
- B. **Hazardous Substance Discharge.** Except as provided in Water Code section 13271(b), any person who, without regard to intent or negligence, causes or permits any hazardous substance or sewage to be discharged in or on any waters of the State, shall as soon as (a) that person has knowledge of the discharge, (b) notification is possible, and (c) notification can be provided without substantially impeding cleanup or other emergency measures, immediately notify the County of San Diego, in accordance with California Health and Safety Code section 5411.5 and the California Office of Emergency Services of the discharge in accordance with the spill reporting provision of

the State toxic disaster contingency plan adopted pursuant to Government Code Title 2, Division 1, Chapter 7, Article 3.7 (commencing with section 8574.17), and immediately notify the State Water Board or the San Diego Water Board of the discharge. This provision does not require reporting of any discharge of less than a reportable quantity as provided for under subdivisions (f) and (g) of section 13271 of the Water Code unless the Applicant is in violation of a Basin Plan prohibition.

- C. **Oil or Petroleum Product Discharge.** Except as provided in Water Code section 13272(b), any person who without regard to intent or negligence, causes or permits any oil or petroleum product to be discharged in or on any waters of the State, or discharged or deposited where it is, or probably will be, discharged in or on any waters of the State, shall, as soon as (a) such person has knowledge of the discharge, (b) notification is possible, and (c) notification can be provided without substantially impeding cleanup or other emergency measures, immediately notify the California Office of Emergency Services of the discharge in accordance with the spill reporting provision of the State oil spill contingency plan adopted pursuant to Government Code Title 2, Division 1, Chapter 7, Article 3.7 (commencing with section 8574.1). This requirement does not require reporting of any discharge of less than 42 gallons unless the discharge is also required to be reported pursuant to Clean Water Act section 311, or the discharge is in violation of a Basin Plan prohibition.
- D. **Anticipated Noncompliance.** The Applicant shall give advance notice to the San Diego Water Board of any planned changes in the Project or the Compensatory Mitigation project which may result in noncompliance with Certification conditions or requirements.
- E. **Commencement of Construction Notification.** The Applicant must notify the San Diego Water Board in writing at least 5 days prior to the start of initial Project construction ground disturbance
- F. **Transfers.** This Certification is not transferable in its entirety or in part to any person or organization except after notice to the San Diego Water Board in accordance with the following terms:
1. **Transfer of Property Ownership:** The Applicant must notify the San Diego Water Board of any change in ownership of the Project area. Notification of change in ownership must include, but not be limited to, a statement that the Applicant has provided the purchaser with a copy of the Section 401 Water Quality Certification and that the purchaser understands and accepts the certification requirements and the obligation to implement them or be subject to liability for failure to do so; the seller and purchaser must sign and date the notification and provide such notification to the San Diego Water Board **within 10 days of the transfer of ownership.**
  2. **Transfer of Mitigation Responsibility:** Any notification of transfer of responsibilities to satisfy the mitigation requirements set forth in this Certification must include a signed statement from an authorized representative of the new party (transferee) demonstrating acceptance and understanding of the responsibility to comply with and fully satisfy the mitigation conditions and agreement that failure to comply with the mitigation conditions and associated requirements may subject the

transferee to enforcement by the San Diego Water Board under Water Code section 13385, subdivision (a). Notification of transfer of responsibilities meeting the above conditions must be provided to the San Diego Water Board **within 10 days of the transfer date.**

3. **Transfer of Post-Construction BMP Maintenance Responsibility:** The Applicant assumes responsibility for the inspection and maintenance of all post-construction structural BMPs until such responsibility is legally transferred to another entity. At the time maintenance responsibility for post-construction BMPs is legally transferred the Applicant must submit to the San Diego Water Board a copy of such documentation and must provide the transferee with a copy of a long-term BMP maintenance plan that complies with manufacturer specifications. The Applicant must provide such notification to the San Diego Water Board **within 10 days** of the transfer of BMP maintenance responsibility.

Upon properly noticed transfers of responsibility, the transferee assumes responsibility for compliance with this Certification and references in this Certification to the Applicant will be interpreted to refer to the transferee as appropriate. Transfer of responsibility does not necessarily relieve the Applicant of responsibility for compliance with this Certification in the event that a transferee fails to comply.

#### **VIII. CALIFORNIA ENVIRONMENTAL QUALITY ACT COMPLIANCE**

- A. The City of Poway is the Lead Agency under the California Environmental Quality Act (CEQA) (Public Resources Code section 21000, et seq.) section 21067, and CEQA Guidelines (California Code of Regulations, title 14, section 15000 et seq.) section 15367, and has filed a Notice of Determination dated August 1, 1991 for the Final Environmental Impact Report (FEIR) titled Conditional Use Permit 89-05/Reclamation Plan 89-05: CalMat-Poway Subsequent EIR (State Clearing House Number 89010025). The Lead Agency has determined the Project will have a significant effect on the environment and mitigation measures were made a condition of the Project.
- B. The San Diego Water Board is a Responsible Agency under CEQA (Public Resources Code section 21069; CEQA Guidelines section 15381). The San Diego Water Board has considered the Lead Agency's FEIR and finds that the Project as proposed will have a significant effect on resources within the San Diego Water Board's purview.
- C. The San Diego Water Board has required mitigation measures as a condition of this Certification to avoid or reduce the environmental effects of the Project to resources within the Board's purview to a less than significant level.
- D. The Lead Agency has adopted a mitigation monitoring and reporting program pursuant to Public Resources Code section 21081.6 and CEQA Guidelines section 15097 to ensure that mitigation measures and revisions to the Project identified in the FEIR are implemented. The Mitigation Monitoring and Reporting Program (MMRP) is included and incorporated by reference in Attachment 5 to this Certification. The Applicant shall implement the Lead Agency's MMRP described in the FEIR, as it pertains to resources within the San Diego Water Board's purview. The San Diego Water Board has imposed additional MMRP requirements as specified in sections V and VI of this Certification.

- E. As a Responsible Agency under CEQA, the San Diego Water Board will file a Notice of Determination in accordance with CEQA Guidelines section 15096 subdivision (i).

#### IX. SAN DIEGO WATER BOARD CONTACT PERSON

Alan Monji, Environmental Scientist  
Telephone: (619)-521-3968  
Email: [Alan.Monji@waterboards.ca.gov](mailto:Alan.Monji@waterboards.ca.gov)

#### X. WATER QUALITY CERTIFICATION

I hereby certify that the proposed discharge from the **Poway Mine Site** (Certification No. 12C-079) will comply with the applicable provisions of sections 301 ("Effluent Limitations"), 302 ("Water Quality Related Effluent Limitations"), 303 ("Water Quality Standards and Implementation Plans"), 306 ("National Standards of Performance"), and 307 ("Toxic and Pretreatment Effluent Standards") of the Clean Water Act. This discharge is also regulated under State Water Board Order No. 2003-0017-DWQ, "*Statewide General Waste Discharge Requirements for Dredged or Fill Discharges that have Received State Water Quality Certification (General WDRs)*," which requires compliance with all conditions of this Water Quality Certification. Please note that enrollment under Order No. 2003-017-DWQ is conditional and, should new information come to our attention that indicates a water quality problem, the San Diego Water Board may issue individual waste discharge requirements at that time.

Except insofar as may be modified by any preceding conditions, all Certification actions are contingent on (a) the discharge being limited to, and all proposed mitigation being completed in strict compliance with, the applicants' Project description and/or the description in this Certification, and (b) compliance with all applicable requirements of the Basin Plan.

I, David W. Gibson, Executive Officer, do hereby certify the forgoing is a full, true, and correct copy of Certification No. 12C-079 issued on July 27, 2017.

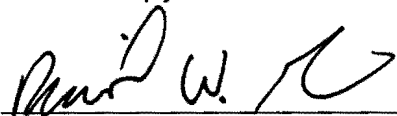

DAVID W. GIBSON  
Executive Officer  
San Diego Water Board

27 July 2017

Date

# ATTACHMENT 1

## DEFINITIONS

**Activity** - when used in reference to a permit means any action, undertaking, or project including, but not limited to, construction, operation, maintenance, repair, modification, and restoration which may result in any discharge to waters of the state.

**Buffer** - means an upland, wetland, and/or riparian area that protects and/or enhances aquatic resource functions associated with wetlands, rivers, streams, lakes, marine, and estuarine systems from disturbances associated with adjacent land uses.

**California Rapid Assessment Method (CRAM)** - is a wetland assessment method intended to provide a rapid, scientifically-defensible and repeatable assessment methodology to monitor status and trends in the conditions of wetlands for applications throughout the state. It can also be used to assess the performance of compensatory mitigation projects and restoration projects. CRAM provides an assessment of overall ecological condition in terms of four attributes: landscape context and buffer, hydrology, physical structure and biotic structure. CRAM also includes an assessment of key stressors that may be affecting wetland condition and a "field to PC" data management tool (eCRAM) to ensure consistency and quality of data produced with the method.

**Compensatory Mitigation Project** - means compensatory mitigation implemented by the Applicant as a requirement of this Certification (i.e., applicant -responsible mitigation), or by a mitigation bank or an in-lieu fee program.

**Discharge of dredged material** – means any addition of dredged material into, including redeposit of dredged material other than incidental fallback within, the waters of the United States and/or State.

**Discharge of fill material** – means the addition of fill material into waters of the United States and/or State.

**Dredged material** – means material that is excavated or dredged from waters of the United States and/or State.

**Ecological Success Performance Standards** – means observable or measurable physical (including hydrological), chemical, and/or biological attributes that are used to determine if a compensatory mitigation project meets its objectives.

**Enhancement** – means the manipulation of the physical, chemical, or biological characteristics of an aquatic resource to improve a specific aquatic resource function(s). Enhancement results in the gain of selected aquatic resource function(s), but may also lead to a decline in other aquatic resource function(s). Enhancement does not result in a gain in aquatic resource area.

**Establishment** – means the manipulation of the physical, chemical, or biological characteristics present to develop an aquatic resource that did not previously exist. Creation results in a gain in aquatic resource area.

**Fill material** – means any material used for the primary purpose of replacing an aquatic area with dry land or of changing the bottom elevation of a water body.

**Isolated wetland** – means a wetland with no surface water connection to other aquatic resources.

**Mitigation Bank** – means a site, or suite of sites, where resources (e.g., wetlands, streams, riparian areas) are restored, established, enhanced, and/or preserved for the purpose of providing mitigation for impacts authorized by this Certification.

**Preservation** - means the removal of a threat to, or preventing the decline of, aquatic resources by an action in or near those aquatic resources. This term includes activities commonly associated with the protection and maintenance of aquatic resources through the implementation of appropriate legal and physical mechanisms. Preservation does not result in a gain of aquatic resource area or functions.

**Re-establishment** - means the manipulation of the physical, chemical, or biological characteristics of a site with the goal of returning natural/ historic functions to a former aquatic resource. Re-establishment results in rebuilding a former aquatic resource and results in a gain in aquatic resource area and functions.

**Rehabilitation** - means the manipulation of the physical, chemical, or biological characteristics of a site with the goal of repairing natural/ historic functions to a degraded aquatic resource. Rehabilitation results in a gain in aquatic resource function, but does not result in a gain in aquatic resource area.

**Restoration** - means the manipulation of the physical, chemical, or biological characteristics of a site with the goal of returning natural/historic functions to a former or degraded aquatic resource. For the purpose of tracking net gains in aquatic resource area, restoration is divided into two categories: re-establishment and rehabilitation.

**Start of Project Construction** - For the purpose of this Certification, "start of Project construction" means to engage in a program of on-site construction, including site clearing, grading, dredging, landfilling, changing equipment, substituting equipment, or even moving the location of equipment specifically designed for a stationary source in preparation for the fabrication, erection or installation of the building components of the stationary source within waters of the United States and/or State.

**Uplands** - means non-wetland areas that lack any field-based indicators of wetlands or other aquatic conditions. Uplands are generally well-drained and occur above (i.e., up-slope) from nearby aquatic areas. Wetlands can, however, be entirely surrounded by uplands. For example, some natural seeps and constructed stock ponds lack aboveground hydrological connection to other aquatic areas. In the watershed context, uplands comprise the landscape matrix in which aquatic areas form. They are the primary sources of sediment, surface runoff, and associated chemicals that are deposited in aquatic areas or transported through them.

**Water quality objectives and other appropriate requirements of state law** – means the water quality objectives and beneficial uses as specified in the appropriate water quality control plan(s); the applicable provisions of sections 301, 302, 303, 306, and 307 of the Clean Water Act; and any other appropriate requirement of state law.



**Waters of the State** - means any surface water or groundwater, including saline waters, within the boundaries of the State. [Water Code section 13050, subd. (e)].



## **ATTACHMENT 2**

### **LOCATION MAPS**

1. ECORP Consulting, Inc. Figure 1, Regional Location – Poway Mine Facility.
2. ECORP Consulting, Inc. Figure 2, Site Location – Poway Facility.

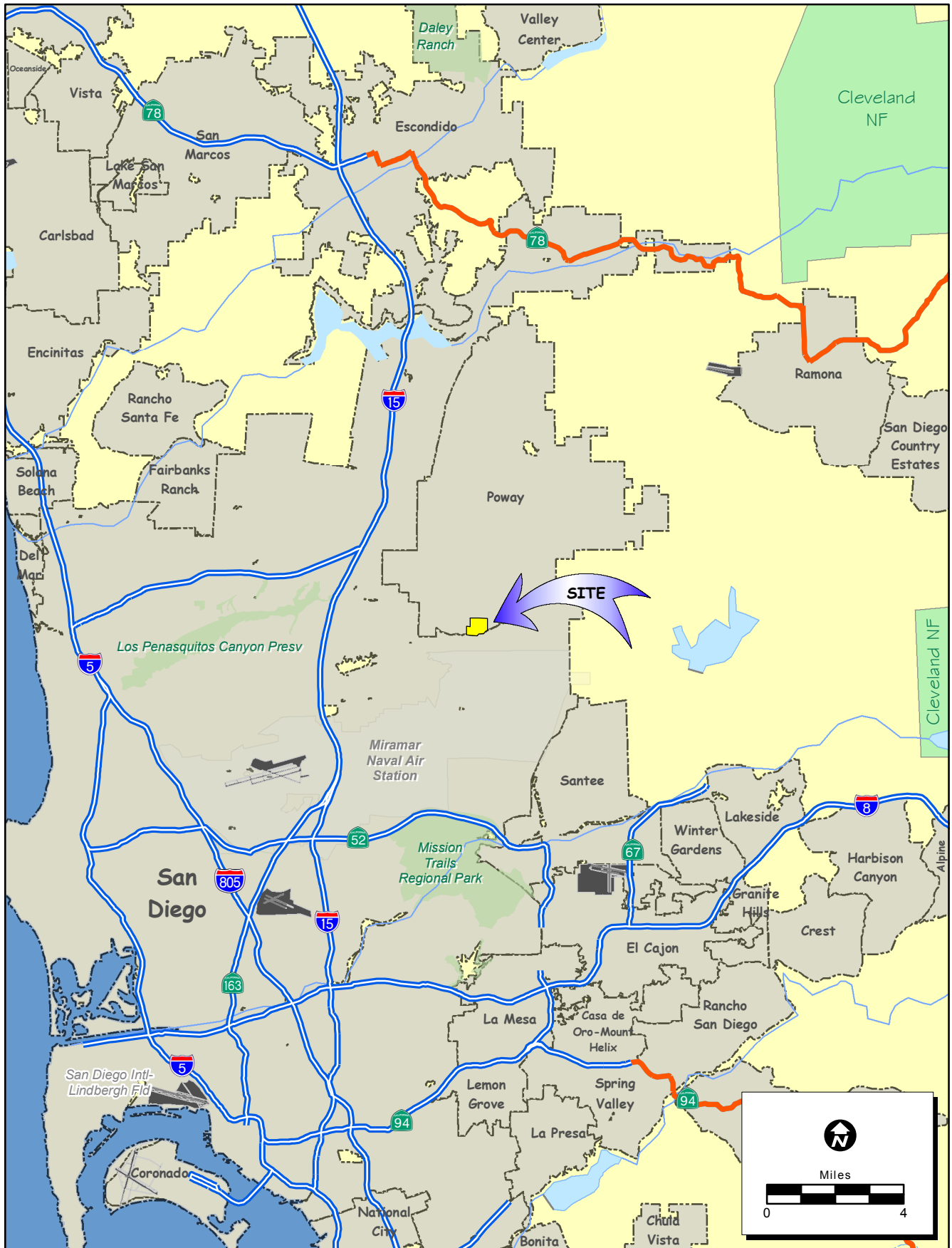

R:\AAA\_ECORP\_Projects\2006\_199\_Vulcan\_Poway\_Mari\Poway\_Vicinity\_v2.mxd

05/30/08

**Figure 1. Regional Location - Poway Mine Facility**

2006-199 Vulcan Poway

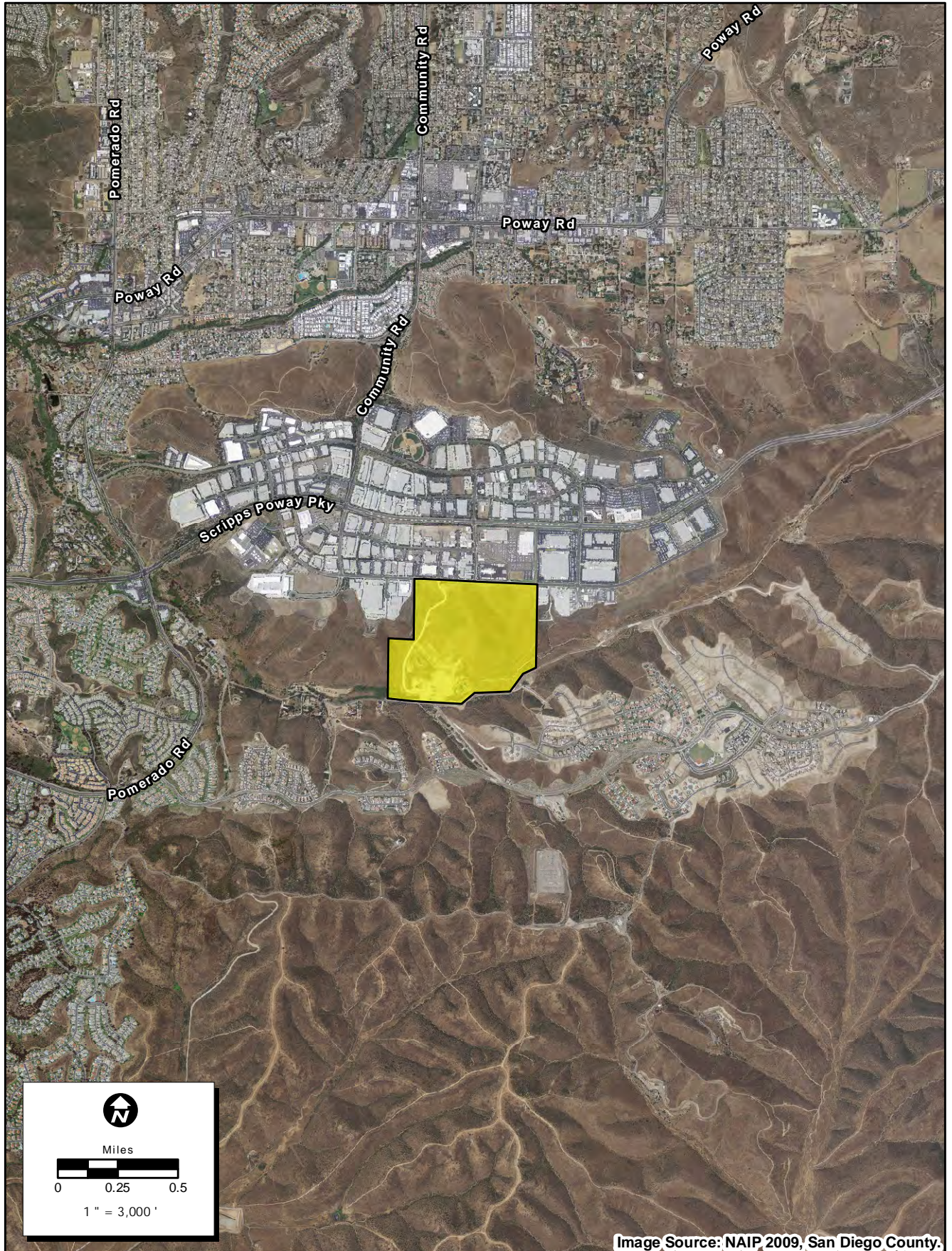

Location: N:\2006\2006-199 Poway Mine Site (Vulcan Poway)\MAPS\SITE\_VICINITY\PowaySiteLocation\_TenPointOb.mxd (eck, 7/27/2012)

**Figure 2. Site Location - Poway Facility**

2006-199 Vulcan Poway

### **ATTACHMENT 3**

#### **PROJECT SITE PLANS**

1. ECORP Consulting, Inc. Figure 4, Site Overview.
2. ECORP Consulting, Inc. Figure 8, Project Components.
3. ECORP Consulting, Inc. Figure 11a, U.S.A.C.E. Impacts.
4. ECORP Consulting, Inc. Figure 11b, CDFW Impacts.

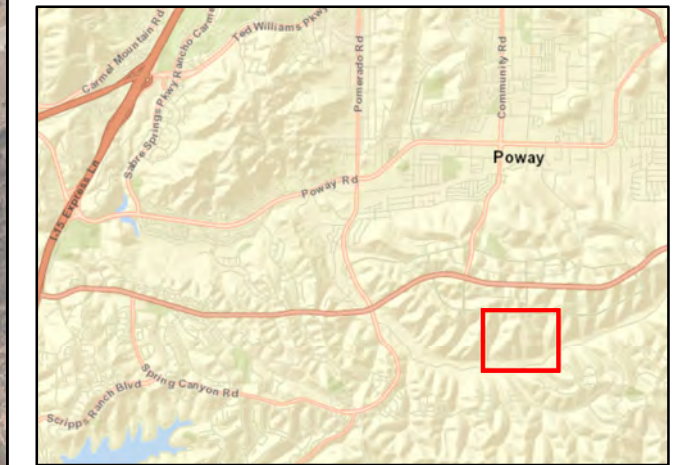

**Figure 4.  
Site Overview**

**Map Features**

- Poway Property Boundary
- Drainage

Service Layer Credits: Sources: Esri, HERE, DeLorme, USGS, Intermap, INCREMENT P, NRCan, Esri Japan, METI, Esri China (Hong Kong), Esri Korea, Esri (Thailand), MapmyIndia, NGCC, © OpenStreetMap contributors, and the GIS User Community



Location: N:\2006\2006-199 Poway Mine Site (Vulcan Poway)\MAPS\REPORT\_FIGURES\HEMP\4\_2017\2017\_01\_19\_Poway\_BeelerReaches\_Poway\_BeelerReaches\_20170119.mxd (JDS edit) jfctsa 1/20/2017

Location: N:\2006\2006-199 Vulcan Poway Mine Site (Vulcan Poway)\MAPS\REPORT\_FIGURES\HEMP\3\_2016\Poway\_ProjectComponents\_20161010.mxd ((JDS edit))\swager 10/31/2016

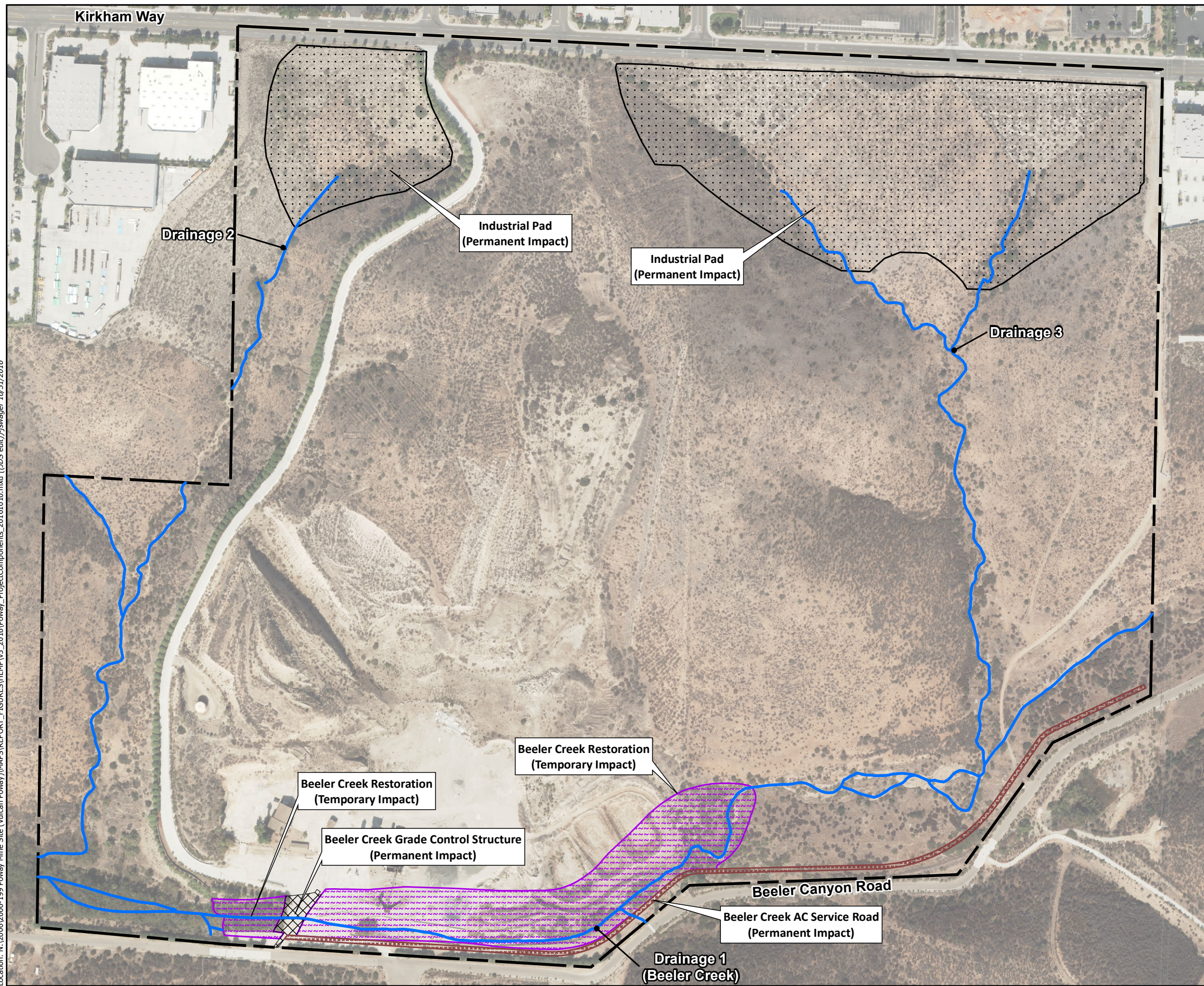

### Figure 8. Project Components

- Map Features**
- Poway Property Boundary
  - Drainage
- Project Components**
- Beeler Creek AC Service Road
  - Beeler Creek Grade Control Structure
  - Beeler Creek Restoration
  - Industrial Pad

Service Layer Credits: Sources: Esri, HERE, DeLorme, USGS, Intermap, increment P Corp., NRCAN, Esri Japan, METI, Esri China (Hong Kong), Esri (Thailand), MapmyIndia, © OpenStreetMap contributors, and the GIS User Community

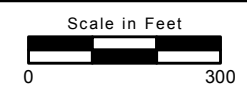
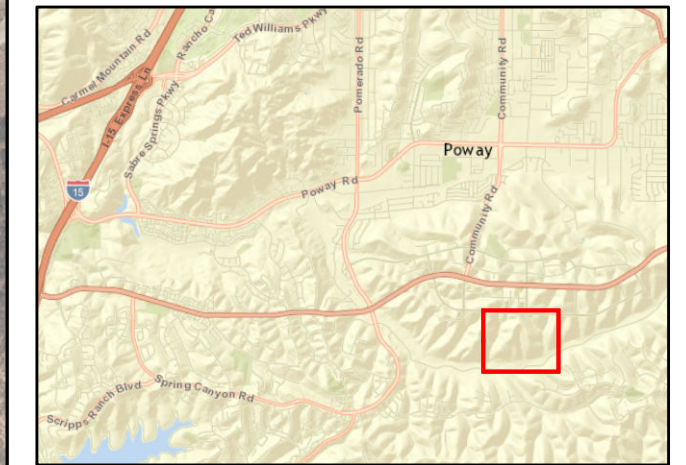



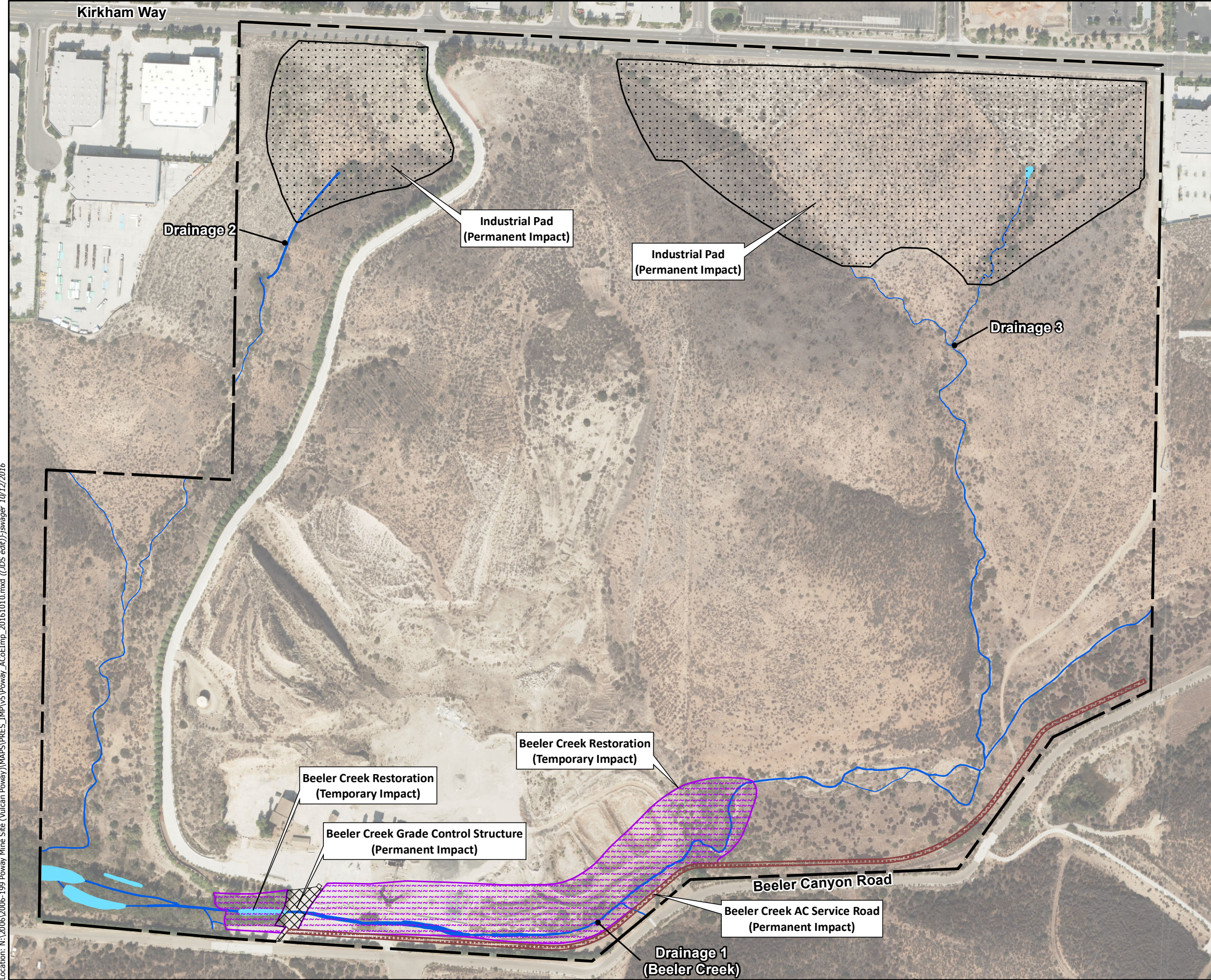

**Figure 11a.**  
**U.S.A.C.E. Impacts**

**Map Features**

Poway Property Boundary

**ACoE Features**

Ephemeral Drainage

Fresh Water Marsh

**Project Components**

Beeler Creek AC Service Road

Beeler Creek Grade Control Structure

Beeler Creek Restoration

Industrial Pad

Service Layer Credits: Sources: Esri, HERE, DeLorme, USGS, Intermap, increment P Corp., NRCAN, Esri Japan, METI, Esri China (Hong Kong), Esri (Thailand), MapmyIndia, © OpenStreetMap contributors, and the GIS User Community

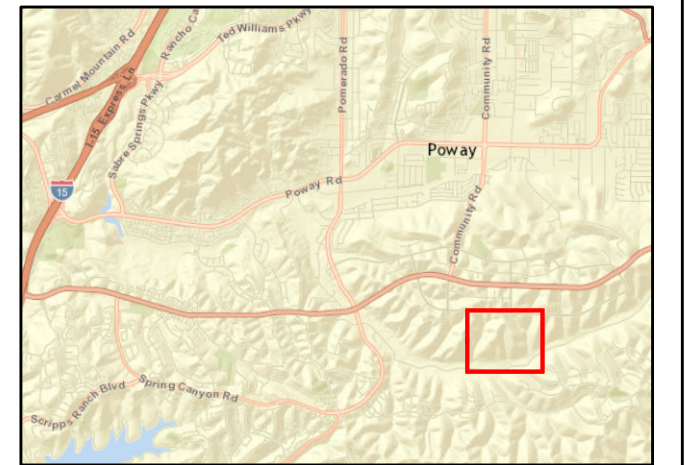

Location: N:\2006\2006-199 Vulcan Poway Mine Site (Vulcan Poway)\MAPS\PRES\MPV5\Poway\_ACoEImp\_20161010.mxd ((JDS edit))\swager\_10/12/2016

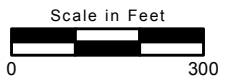

**Figure 11b.  
CDFW Impacts**

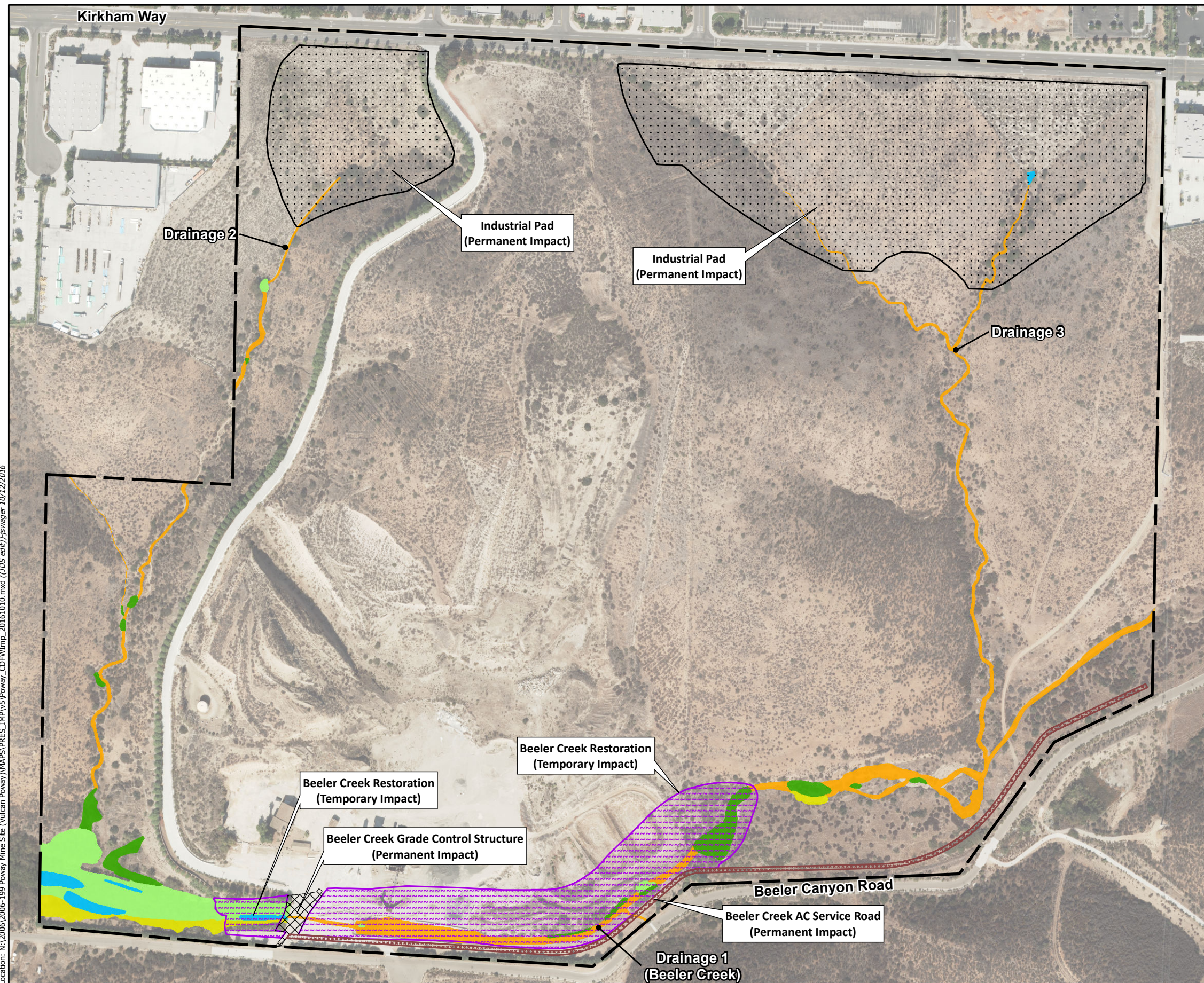

**Map Features**

Poway Property Boundary

**CDFW Habitat**

Baccharis Scrub

Fresh Water Marsh

Mulefat Scrub

Southern Willow Scrub

CDFW Streambed

**Project Components**

Beeler Creek AC Service Road

Beeler Creek Grade Control Structure

Beeler Creek Restoration

Industrial Pad

Service Layer Credits: Sources: Esri, HERE, DeLorme, USGS, Intermap, increment P Corp., NRCAN, Esri Japan, METI, Esri China (Hong Kong), Esri (Thailand), MapmyIndia, © OpenStreetMap contributors, and the GIS User Community

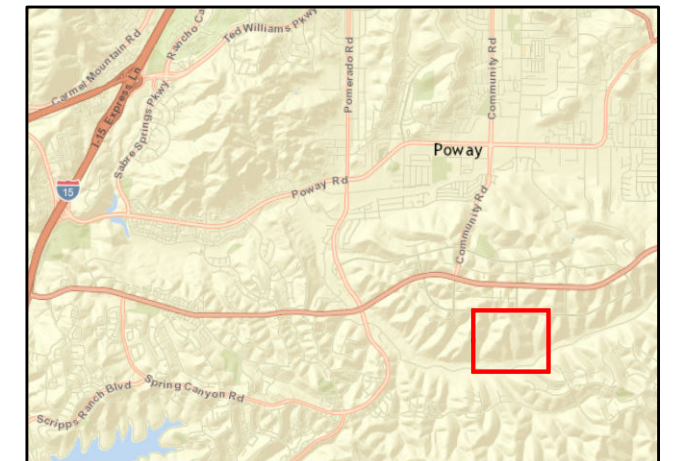

Location: N:\2006\2006-199 Vulcan Poway Mine Site (Vulcan Poway)\MAPS\PRES\MPV5\Poway\_CDFWImp\_20161010.mxd (DPS edit)-svager\_10/12/2016

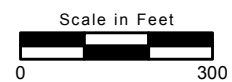

## **ATTACHMENT 4**









### **RESTORATION DESIGN PLANS**

1. ECORP Consulting, Inc. Figure 6, Channel Design for the Central Reach of Beeler Creek.
2. BDS Engineering, Inc. Figure 7a, Detail of Drop Structure and Emergency Crossing.
3. BDS Engineering, Inc. Figure 7b, Detail of Drop Structure and Emergency Crossing.



Location: N:\2006\2006-199 Vulcan Poway Mine Site (Vulcan Poway)\MAPS\REPORT\_FIGURES\HEMP\4\_19\_Poway\_BeelerReaches\Poway\_Channel\Desig\_Channel\Desig\_Channel\1/20/2017

### Figure 6. Channel Design for the Central Reach of Beeler Creek

#### Map Features

-  Poway Property Boundary - 169.6 ac.
-  Beeler Creek (Drainage 1)
- Beeler Creek Improvement Plans <sup>1</sup>**
-  Channel - 3.53 ac.
-  AC Service Road - 0.77 ac.
-  Concrete Access Road - 0.09 ac.
-  Grouted Riprap - 0.04 ac.
-  UngROUTed Riprap - 0.09 ac.
-  Upland Restoration Area/Channel Slope

#### Project Components

-  Beeler Creek AC Service Road
-  Beeler Creek Grade Control Structure
-  Industrial Pad

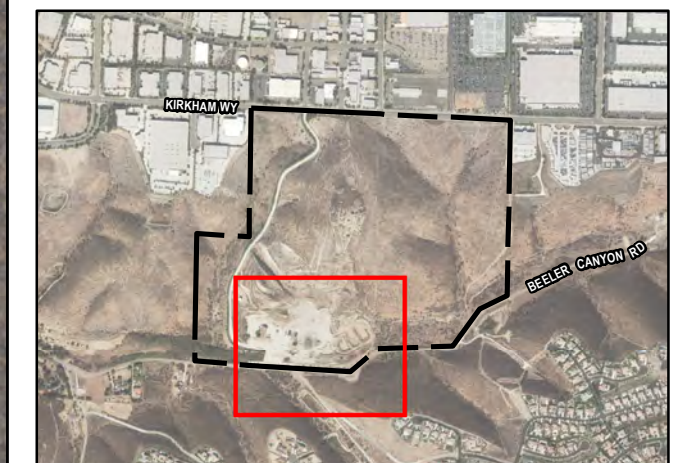

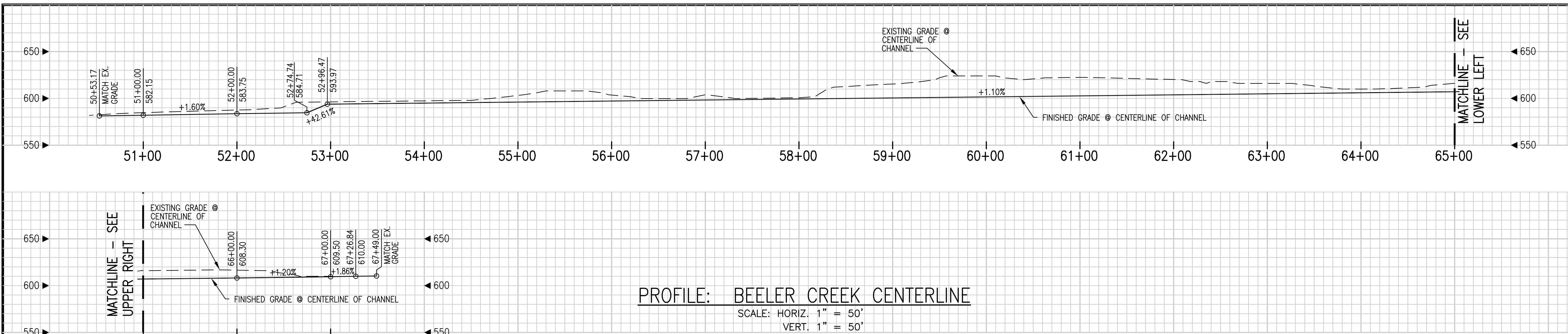

**PROFILE: BEELER CREEK CENTERLINE**

SCALE: HORIZ. 1" = 50'  
VERT. 1" = 50'

**LEGEND**

ALL SCREENED ITEMS ARE EXISTING

EXISTING BUILDING	CONCRETE ACCESS ROAD	1.92 ACRES
EXISTING CHAIN LINK FENCE	AC SERVICE ROAD	3.53 ACRES
EXISTING TREE	COASTAL SAGE SCRUB RESTORATION AREAS	0.52 ACRES
EXISTING TREE LINE	CHANNEL (NO PLANTINGS)	6" AC BERM
EXISTING CONTOURS	REVEGETATED WILLOW MULEFAT SCRUB	
EXISTING SPOT ELEVATION		
APPROXIMATE FUTURE RECLAMATION CONTOUR		
DAYLIGHT LINE		
NEW CONTOUR		
NEW SPOT ELEVATION		
DIRECTION OF FLOW		
NEW SLOPES		
NEW CHANNEL		
LOW FLOW CHANNEL		
GROUTED RIP RAP		
UNGROUTED RIP RAP		

SCALE: 1" = 50'

GRAPHIC SCALE

0 25' 50' 100' 150'

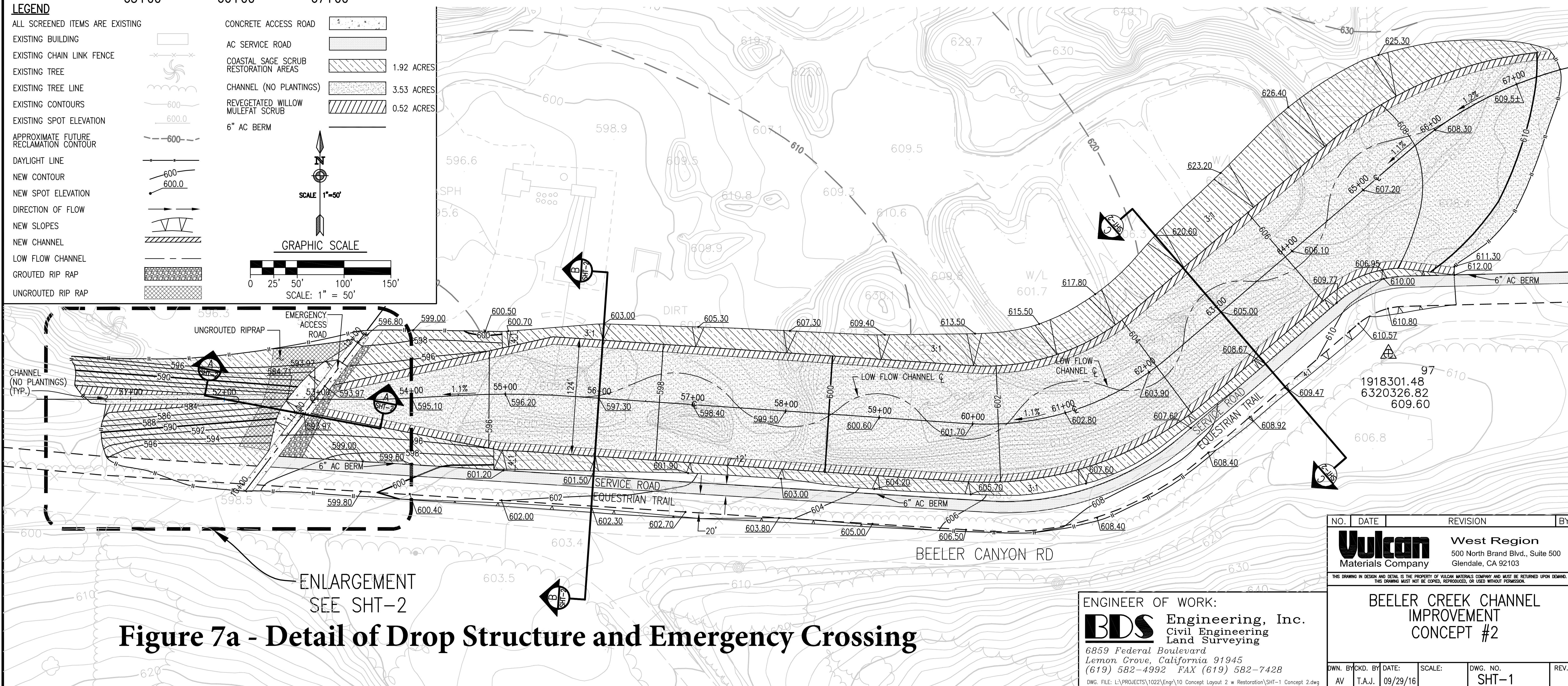

**Figure 7a - Detail of Drop Structure and Emergency Crossing**

ENLARGEMENT  
SEE SHT-2

ENGINEER OF WORK:  
**BDS** Engineering, Inc.  
Civil Engineering  
Land Surveying  
6859 Federal Boulevard  
Lemon Grove, California 91945  
(619) 582-4992 FAX (619) 582-7428  
DWG. FILE: L:\PROJECTS\1022\Eng\10 Concept Layout 2 w Restoration\SHT-1 Concept 2.dwg

NO.	DATE	REVISION	BY
<b>Vulcan</b> West Region Materials Company 500 North Brand Blvd., Suite 500 Glendale, CA 92103			
BEELER CREEK CHANNEL IMPROVEMENT CONCEPT #2			
DWN. BY	CKD. BY	DATE	SCALE
AV	T.A.J.	09/29/16	DWG. NO.
			SHT-1
			REV.

File Name: L:\PROJECTS\1022\Eng\10 Concept Layout 2 w Restoration\SHT-1 Concept 2.dwg Oct 03 2016 6:55:48am

# Figure 7b - Detail of Drop Structure and Emergency Crossing

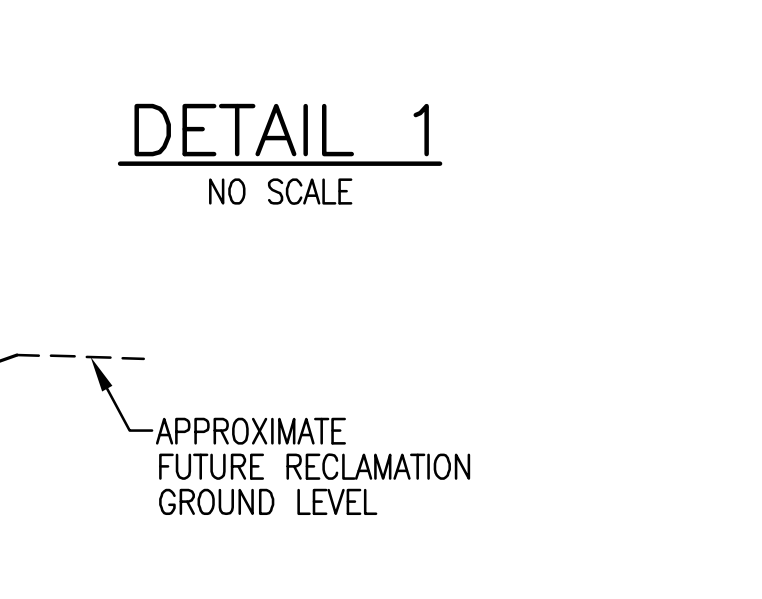
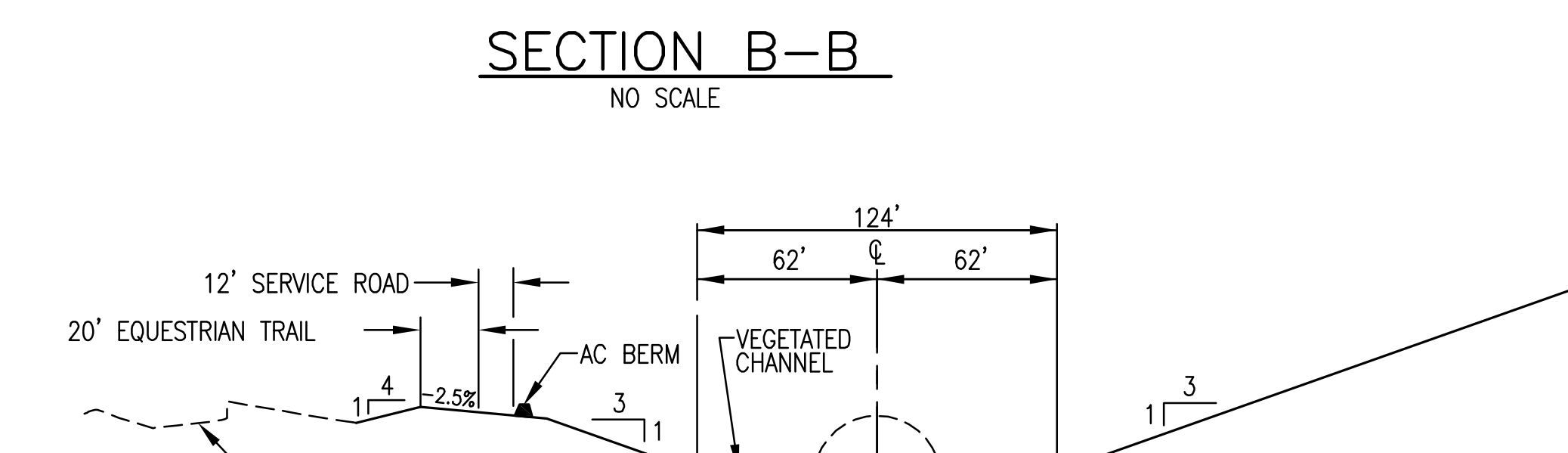
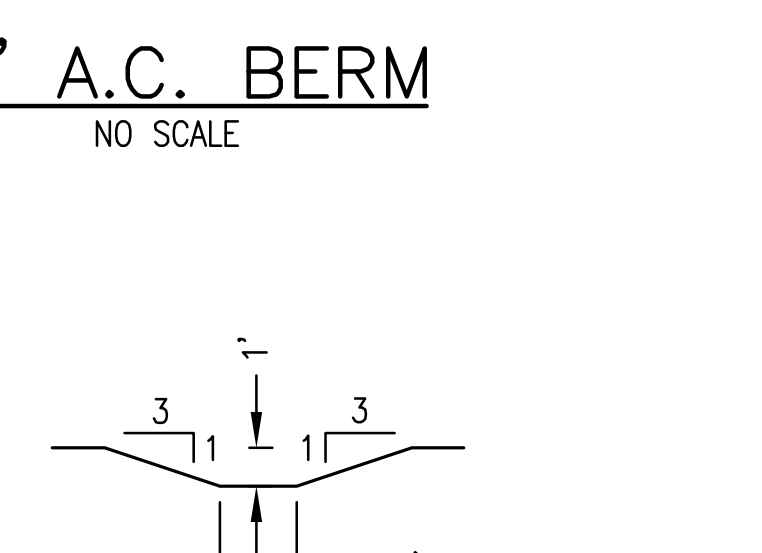
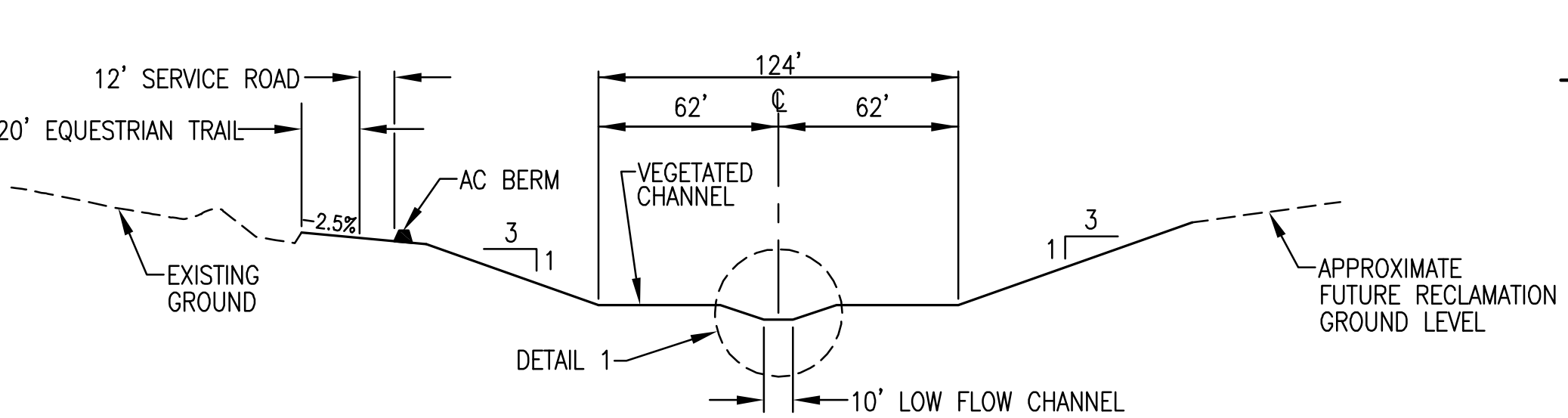
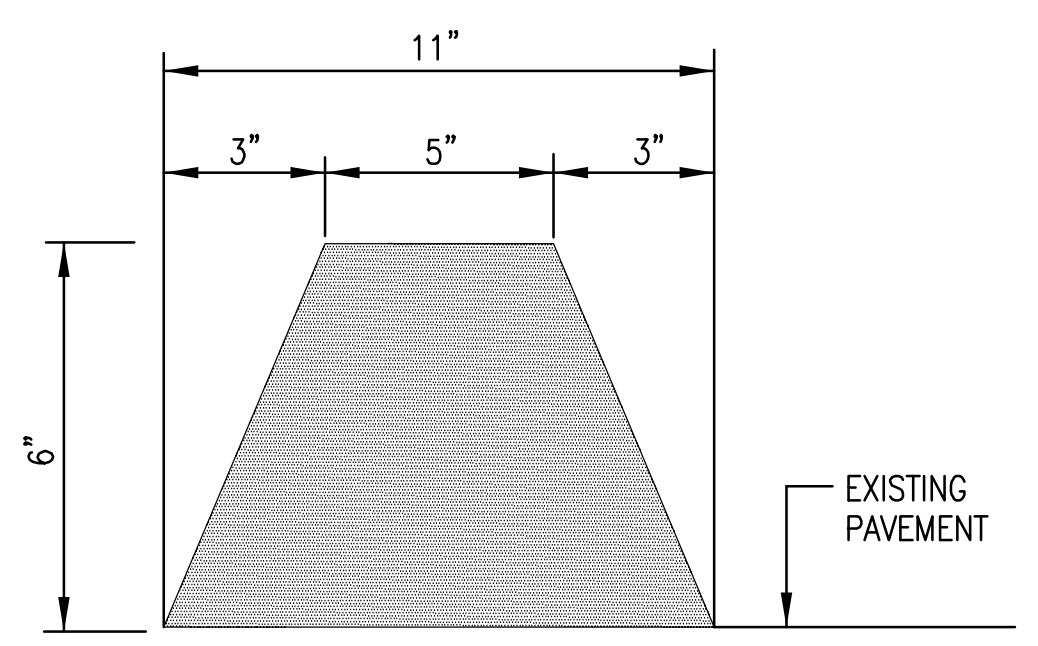
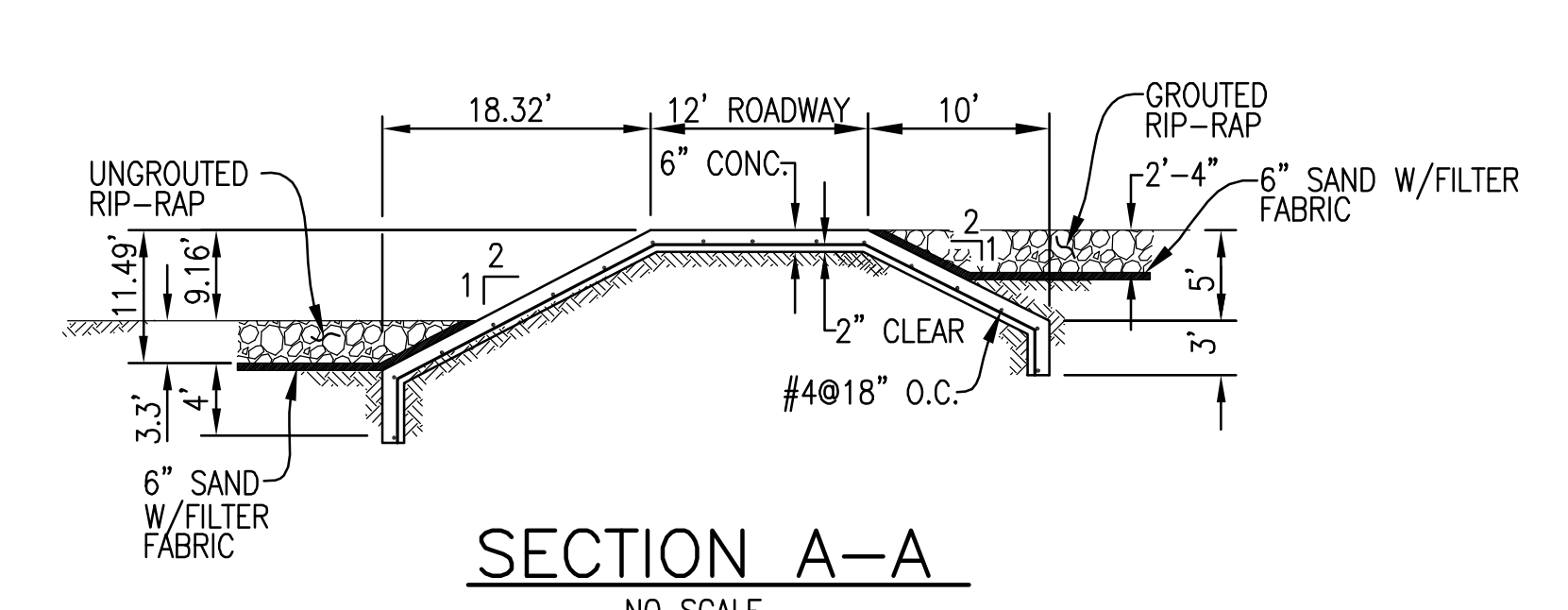
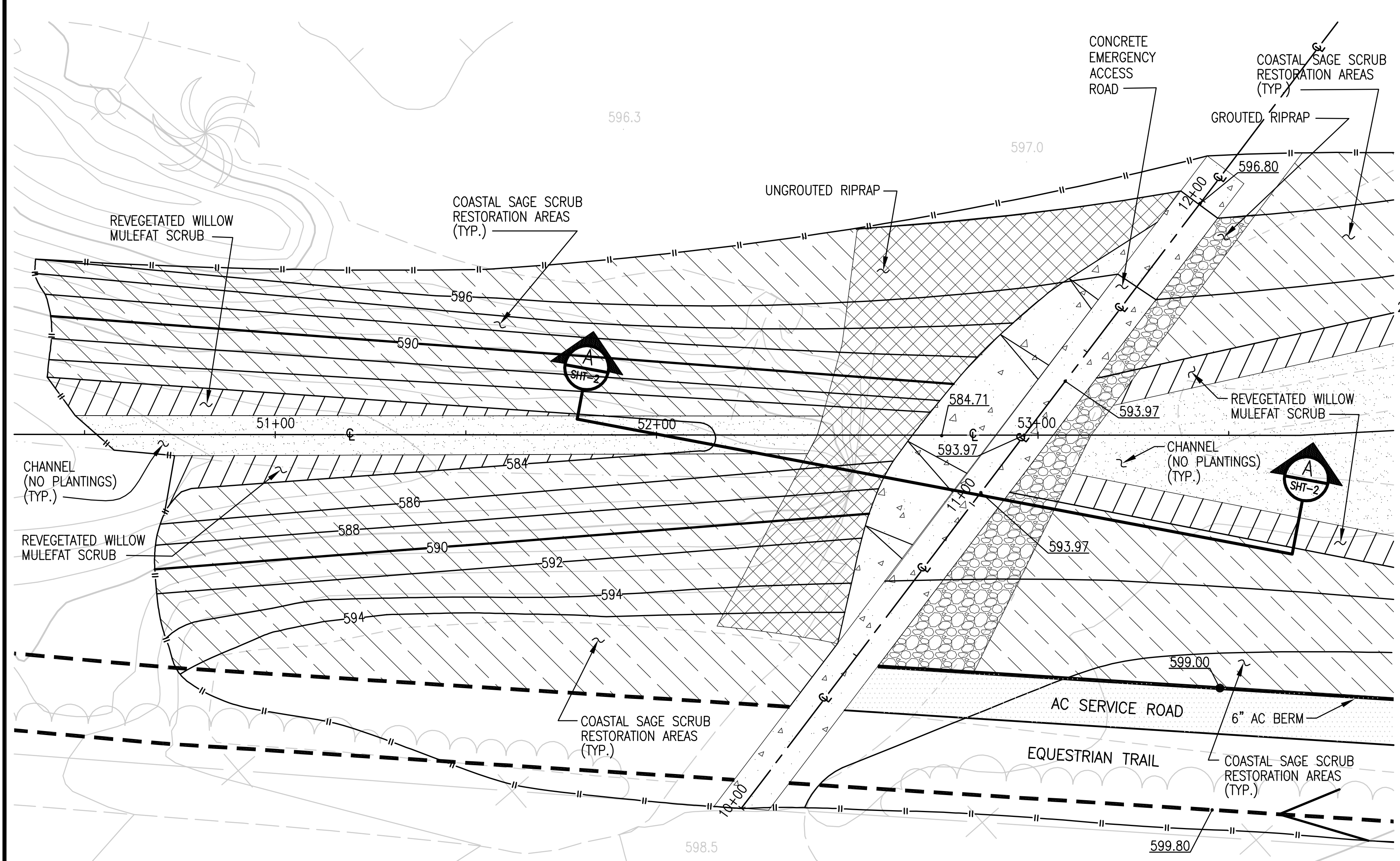
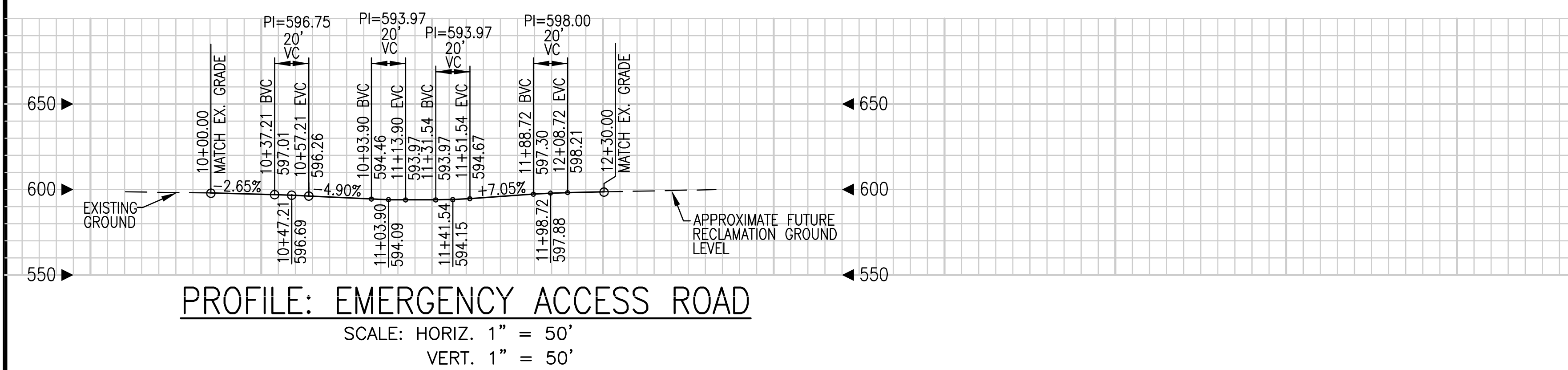

ENLARGEMENT  
SCALE: 1" = 20'

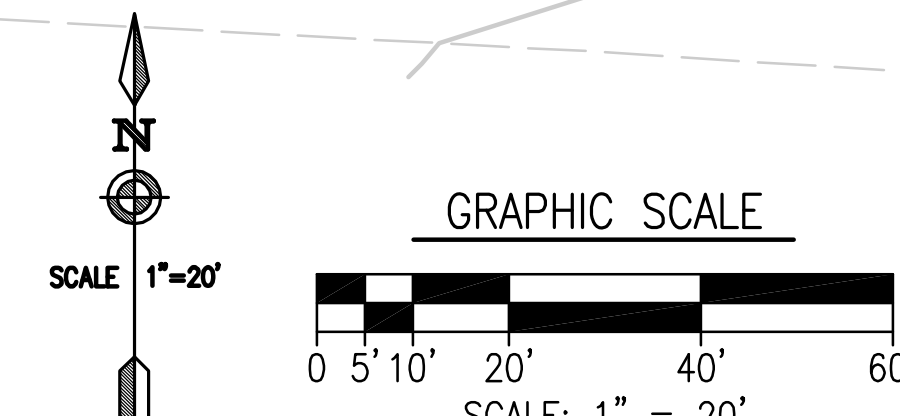

ENGINEER OF WORK:  
**BDS** Engineering, Inc.  
Civil Engineering  
Land Surveying  
6859 Federal Boulevard  
Lemon Grove, California 91945  
(619) 582-4992 FAX (619) 582-7428  
DWG. FILE: L:\PROJECTS\1022\Eng\10 Concept Layout 2 w Restoration\SH2-2 Concept 2.dwg

NO.	DATE	REVISION	BY
<b>West Region</b> 500 North Brand Blvd., Suite 500 Glendale, CA 92103			
THIS DRAWING IN DESIGN AND DETAIL IS THE PROPERTY OF VULCAN MATERIALS COMPANY AND MUST BE RETURNED UPON DEMAND. THIS DRAWING MUST NOT BE COPIED, REPRODUCED, OR USED WITHOUT PERMISSION.			
<b>BEELER CREEK CHANNEL IMPROVEMENT CONCEPT #2</b>			
DWN. BY	CKD. BY	DATE	SCALE
AV	T.A.J.	09/29/16	DWG. NO.
			SH2-2
			REV.

File Name: L:\PROJECTS\1022\Eng\10 Concept Layout 2 w Restoration\SH2-2 Concept 2.dwg Oct 03 2016 6:55am

## **ATTACHMENT 5**

### **MITIGATION MONITORING AND REPORTING PROGRAM**

1. Environmental Impact Report excerpt, Vulcan Poway, Mitigation and Monitoring Reporting Program.

# 12C-079 Vulcan Poway

## EIR Excerpt: MMRP

### Biological Resources

#### RECOMMENDED MITIGATION MEASURES

To reduce the level of impacts to important biological resources present on this site, a number of measures are recommended - these follow below. Fully mitigating all adverse impacts to sensitive biological resources found here to a point at which they are not significant, or to a level below significance, is not feasible, and it should be recognized that significant, unmitigable impacts will remain. Overriding considerations per the California Environmental Quality Act would be developed for City Council action typical of any aggregate operation with significant biological impacts.

- 1) A "spring survey" should be conducted in April through June to assess the status and distribution of the following sensitive species which are potentially present on-site: San Diego Thorn-mint, Orcutt's Brodiaea, San Diego Goldenstar, California Adder's-tongue Fern, and Variegated Dudleya. All but the last of these would occur in the Southern California Grassland or adjacent areas. Variegated Dudleya could occur in dry Diegan Coastal Sage Scrub habitat. These are significant species, and the presence of any of these in substantial numbers would constitute a regionally important biological resource of this site, requiring additional mitigation.
- 2) Impacts to the on-site Riparian Scrub habitat would be avoided by all grading operations. An open space easement would be designated on the CUP. If inadvertent impacts occur, there would be mitigation either on-site through the development of a relatively simple wetland mitigation plan. Such a plan could



## 12C-079 Vulcan Poway

### EIR Excerpt: MMRP

fully mitigate wetland losses which would result from implementation of this project. Such a plan would be prepared by a qualified biologist familiar with such programs, working in concert with a revegetation specialist or certified landscape architect. A two-to-one habitat replacement ratio should fully compensate for the wetland loss on this site. A five-year monitoring program would also be required.

- 3) Impacts to on-site Diegan Coastal Sage Scrub vegetation would be partially mitigated by the development of a Diegan Coastal Sage Scrub Habitat Restoration Plan, using manufactured slopes areas which would be prepared for this purpose following the completion of extraction activities. This will be incorporated into the restoration plan. Additionally, to ensure success there should be long term biological monitoring, including the preparation of status reports to be reviewed by the City at regular intervals for a minimum of ten years. Such a plan should be prepared by a qualified biologist familiar with such programs, working in concert with a revegetation specialist or certified landscape architect.
- 4) Off-site mitigation to partially compensate for the loss of the site's Southern California Grassland could be developed in the form of habitat restoration and/or enhancement. This would require the identification of target areas, suitable for the establishment or restoration of a diverse native grassland. South Poway still contains several large areas of grassland habitat which could be augmented and/or upgraded through the development of a native grassland restoration project. The specifics of such a plan are beyond the scope of this report; however, it would require, at a minimum (a) off-site restoration or enhancement area identification; (b) the preparation of a precise planting program, specifying species and quantities to be used (based on indigenous taxa and diversity ratios); (c) possible specimen, soil and/or inoculum salvaging from the existing grassland; (d) a complete soil preparation plan; (e) maintenance, including irrigation requirements, the control of exotic annuals, etc; and (f) long-term biological monitoring, including the preparation of status reports to be reviewed by the City at regular intervals for a minimum of five years. Such a plan should be prepared by a qualified biologist

## 12C-079 Vulcan Poway

### EIR Excerpt: MMRP

familiar with such programs, working in concert with a revegetation specialist or certified landscape architect.

- 5) Impacts to the significant population of California Gnatcatchers present on this site may be partially mitigated through an off-site compensation plan. This plan involves the preparation and implementation of a focused California Gnatcatcher Resource Study. Under such a plan, the applicant would work directly with the City of Poway to assist in the establishment of a fund specifically created for the purpose of inventorying and assessing the status of this resource for that area within the City's sphere of influence. In addition, the applicant would contribute funds for the hiring of a part-time biologist/planner for a minimum of one year to develop and implement the study. Tasks directly associated with such a plan include (a) precise mapping of all areas of extant Diegan Coastal Sage Scrub within the study area using low altitude aerial photographs and brief field verification; (b) contacting local biologist familiar with this species to generate an initial data base; (c) conducting focused field reconnaissance surveys of all areas of appropriate habitat; (d) the preparation of a gnatcatcher distribution map and accompanying technical report identifying areas of high-quality habitat and large areas of contiguous habitat; and (e) the identification of areas suitable for preservation, habitat restoration, and/or potential mitigation areas within the study area. Poway has lacked a comprehensive study such as this, and the resultant report and gnatcatcher distribution maps would allow development in the City to be directed in a biologically sensitive manner with respect to this resource. The results of this study could also be incorporated into the City's updated General Plan. In addition, the funding of a study of this nature would demonstrate to state and federal agencies such as the California Department of Fish and Game and the U.S. Fish and Wildlife Service, and private organizations such as the Sierra Club and National Audubon Society, that Poway is concerned about this species. California Gnatcatchers are and will remain an ongoing planning concern throughout coastal Southern California. If this species is placed on the Federal Endangered Species List, development which impacts its habitat would be severely constrained.

## 12C-079 Vulcan Poway

### EIR Excerpt: MMRP

#### MITIGATION MONITORING AND REPORTING PROGRAM

References in the following monitoring requirements apply to the same numerical designations in the mitigation section above.

- 1) The spring survey would be included as a condition of the CUP.
- 2) The CUP will depict an open space easement over the riparian habitat. During the annual review of the CUP, a biologist will confirm that no disturbance has occurred to the wetland resources.
- 3) Approval of the restoration plan will incorporate provisions of the coastal sage scrub vegetation and monitoring program.
- 4) Partial mitigation for the southern California grassland would include off-site acquisition of existing high quality grassland or degraded grassland which could be enhanced.
- 5) Payment toward the California gnatcatcher study and acquisition funding will be made a condition on the CUP.

#### ANALYSIS OF SIGNIFICANCE

The biological impacts are significant and only partially mitigated by the mitigation plan proposed.

# 12C-079 Vulcan Poway

## EIR Excerpt: MMRP

### Land Use

#### RECOMMENDED MITIGATION MEASURES

Since the proposed expansion project is substantially in compliance with the General Plan, and with the South Poway Planned Community regulations and because no significant land use impacts have been identified, no mitigation measures are being recommended on that basis. Mitigation measures for landform alteration and biological resources, however, are recommended in their respective sections of this document. Regarding adjacent land use, barring all heavy truck traffic on Beeler Canyon Road by rerouting on a private access road onto Kirkham Road would mitigate this potentially significant impact to a level below significance. Traffic associated with employees arriving in their personal vehicles via Creek and Beeler Canyon roads would not be considered a significant impact on Creek and Beeler Canyon roads.

#### MITIGATION MONITORING AND REPORTING PROGRAM

Closing Beeler Canyon Road to all heavy truck traffic entering and leaving the CalMat - Poway operation by providing an internal road with access via Kirkham Road within one year of approval of expansion would be a condition of approval for the Conditional Use Permit.

#### ANALYSIS OF SIGNIFICANCE

The proposed project is substantially in conformance with the General Plan and the South Poway Planned Community regulations and no significant land use impacts have been identified. Regarding adjacent land use impacts, significant impacts would be mitigated to a level below significance with the rerouting of heavy truck traffic on a private access roadway with access via Kirkham Road and with the barring of all heavy truck traffic on Beeler Canyon Road.

# 12C-079 Vulcan Poway

## EIR Excerpt: MMRP

### Aesthetics/Landform Alteration

#### RECOMMENDED MITIGATION MEASURES

Although most viewers of the area, with the exception of the General Dynamics viewshed, are shielded from the major portion of the CalMat - Poway site, the steep faces on the sides of the slopes will appear artificial in context with the surrounding terrain. To mitigate landform alteration and visual quality impacts, a revised Reclamation Plan which is sensitive to the existing characteristics of the landform would help reduce the significance of the landform impacts attributable to the proposed project. Undulating the slopes following the original contours of the landform, rather than one large 88-acre pad, would also reduce the landform and visual quality impacts. Transition areas or buffer areas would be set up to blend the graded areas with the native areas to reduce the impact of the landform alteration.

Concurrent reclamation, restricting the disturbance area and revegetating disturbed areas of the slopes before mining begins in another area, would mitigate the potentially significant visual quality impacts. Revegetation would include native and natural plant species, which would include mature plants to blend with the existing vegetation.

#### MITIGATION MONITORING AND REPORTING PROGRAM

City staff would review and City Council would approve a revised Reclamation Plan for the CalMat - Poway site concurrent with the approval of the Conditional Use Permit. The revised Reclamation Plan would be monitored annually to ensure on-going revegetation and reclamation are in conformance with the approved Reclamation Plan.

#### ANALYSIS OF SIGNIFICANCE

There are significant impacts associated with the landform alteration of the 166-acre CalMat - Poway site. Because the topography range is prominent and currently vacant and because the extraction process necessitates removal of the landform, impacts to the landform of the proposed project are considered to be significant. An environmentally

**12C-079 Vulcan Poway**  
**EIR Excerpt: MMRP**

sensitive Reclamation Plan which includes a phased or concurrent revegetation and reclamation process would, however, reduce the significance these impacts but not a below a level of significance. As indicated previously, overriding considerations would be required.

---